

CURRENT MODE PWM CONTROL CIRCUITS—YD3842

DESCRIPTION

The YD3842 provides the necessary features to implement off-line or DC fixed frequency current mode control schemes with a minimal external parts count.

FEATURES

- *Optimized For Off-line and DC to DC Converts
- *Low Start up Current
- *Automatic Feed Forward Compensation
- *Pulse-by-Pulse Current Limiting
- *Under-voltage Lookout with Hysteresis
- *Double Pulse Suppression
- *High Current Totem Pole Output
- *Internally Trimmed Band-gap Reference
- *500kHz Operation

BLOCK DIAGRAM

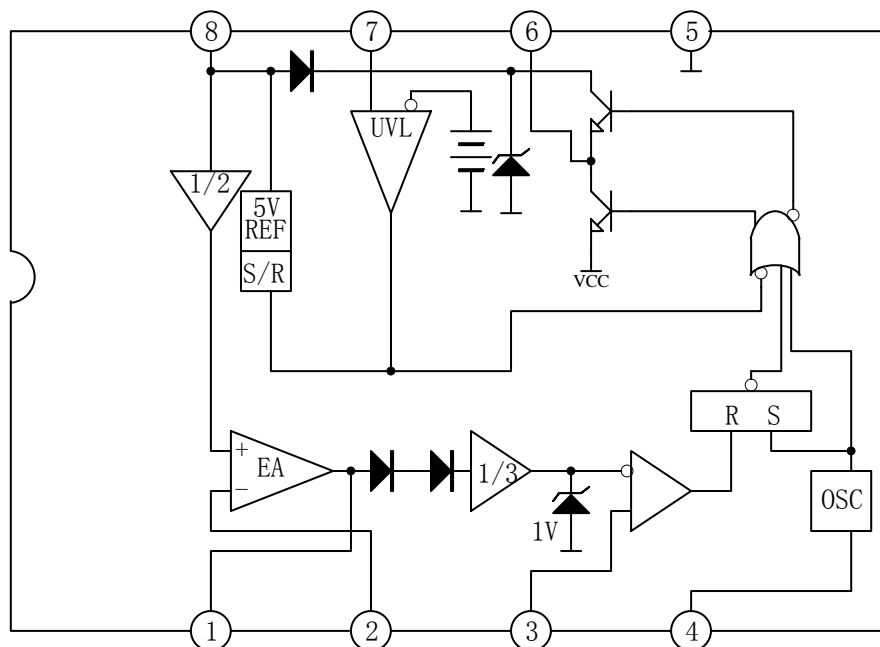

WuXi YouDa Electronics Co., Ltd

Add: No.5 Xijin Road, National Hi-Tech Industrial Development Zone, Wuxi Jiangsu China
 Tel: 86-510-85205117 86-510-85205106 Fax: 86-510-85205110 Website: www.e-youda.com
 SHENZHEN OFFICE Tel: 86-755-83740369 Fax: 86-755-83741418

ABSOLUTE MAXIMUM RATINGS($T_{amb}=25^{\circ}C$)

PARAMETER	SYMBOL	VALUE	UNIT
Supply Voltage (Low impedance Source)	V_{CC}	30	V
Output Current	I_o	± 1	A
Analog Inputs(pin 2, 3)	$V_{I(ANA)}$	-0.3 to +6.3	V
Error Amplifier Output Sink Current	$I_{SINK(EA)}$	10	mA
Power Dissipation	P_D	1.0	W

ELECTRICAL CHARACTERISTICS

($T_{amb}=25^{\circ}C$, $V_{CC1}=10V$, $V_{CC2}=9.5V$, unless otherwise specified)

PARAMETER	SYMBOL	TEST CONDITIONS	MIN	TYP	MAX	UNIT
Reference Section						
Output Voltage	V_{REF}	$T_j=25^{\circ}C$, $I_o=1mA$	4.90	5.00	5.10	V
Line Regulation	ΔV_{REF}	$12 \leq V_{IN} \leq 25V$		6	20	mV
Load Regulation	ΔV_{REF}	$1 \leq I_o = 20mA$		6	25	MV
Output Noise Voltage	V_{ose}	$10Hz \leq f \leq 10kHz$, $T_j=25^{\circ}C$ (note 2)		50	6	mV
Long Term Stability		$T_a=25^{\circ}C$, 1000Hrs (note 2)		5	25	mV
Output Short Circuit	I_{sc}		-30	-100	-180	mA
Oscillator Section						
Initial Accuracy	f	$T_j=25^{\circ}C$	47	52	57	kHz
Voltage Stability	$\Delta f/\Delta V_{CC}$	$12 \leq V_{CC} \leq 25V$		0.2	1	%
Temp Stability		$T_{min} \leq T_A \leq T_{max}$ (note 2)		5		%
Amplitude	V_{osc}	$V_{pin 4}$ peak to peak		1.7		V
Error Amplifier Section						
Input Voltage	$V_{I(EA)}$	$V_{pin 1}=2.5V$	2.42	2.50	2.58	V
Input Bias Current	I_{BIAS}			-0.3	-2	μA
A_{VOL}		$2 \leq V_o \leq 4V$	60	90		dB
Unity Gain Bandwidth		$T_j=25^{\circ}C$ (note 2)	0.7	1	6.0	mHz
PSRR		$12 \leq V_{CC} \leq 25V$	60	70		dB
Output Sink Current	I_{sink}	$V_{pin 2}=2.7V$, $V_{pin 1}=1.1V$	2	6		mA
Output Source Current	I_{source}	$V_{pin 2}=2.3V$, $V_{pin 1}=5V$	-0.5	-0.8		mA
$V_{out High}$	V_{OH}	$V_{pin 2}=2.3V$, $R_L=15k \Omega$ to GND	5	6		V
$V_{out Low}$	V_{OL}	$V_{pin 2}=2.7V$, $V_{pin 1}=1.1V$		0.7	1.1	V

Current Sense Section						
Gain	Gv	(note 3, 4)	2.85	3	3.15	V/V
Maximum Input Signal	$V_{I(MAX)}$	$V_{pin\ 1}=5V$ (note 3)	0.9	1	1.1	V
PSRR		$12 \leq V_{cc} \leq 25V$		70		dB
Input Bias Current	I_{BIAS}			-2	-10	μA
Delay to Output		$V_{pin\ 3}=0\ to\ 2V$		150	300	ns
Output Section						
Output Low Level	V_{OL}	$I_{sink}=20mA$		0.1	0.4	V
		$I_{sink}=200mA$		1.5	2.2	V
Output High Level	V_{OH}	$I_{source}=20mA$	13	13.5		V
		$I_{source}=200mA$	12	13.5		V
Rise Time	t_r	$T_j=25^\circ C, C_L=1nF$ (note 2)		50	150	ns
Fall Time	t_f	$T_j=25^\circ C, C_L=1nF$ (note 2)		50	150	ns
UVLO Saturation		$V_{cc}=5V, I_{sink}=10mA$		0.7	1.2	V
Under-Voltage lockout Output Section						
Start Threshold	$V_{TH(ST)}$		14.5	16	17.5	V
Min. Operating Voltage After Turn On	$V_{OPR(min)}$		8.5	10	11.5	V
PWM Section						
Maximum Duty Cycle	$D_{(MAX)}$		95	07	100	%
Minimum Duty Cycle	$D_{(MIN)}$				0	%
Total Standby Current						
Start-up Current	I_{ST}			0.5	1	mA
Operating Supply Current	$I_{CC(OPR)}$	$V_{pin\ 2}=V_{pin\ 3}=0V$		11	17	mA
V_{cc} Zener Voltage	V_Z	$I_{cc}=25mA$		34		V

APPLICATION CIRCUIT

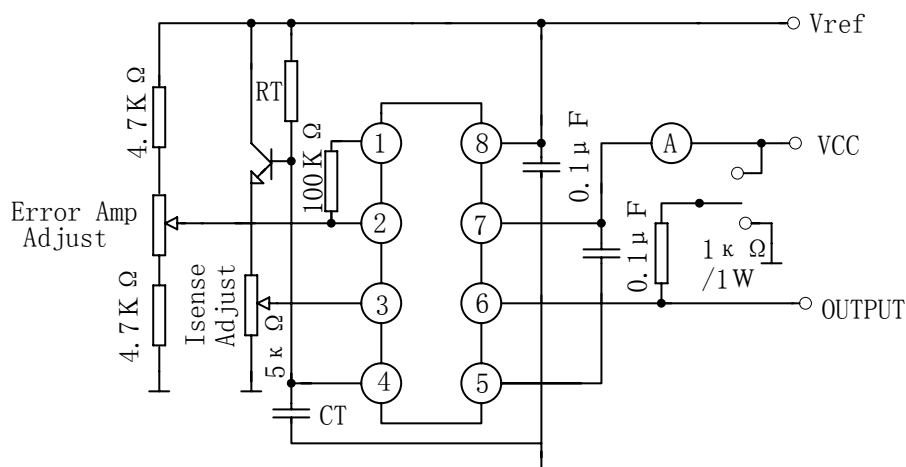

OUTLINE DRAWING

DIP-8

unit:mm

