

Smallest World-Wide 56 KBPS Modem

Description

Xecom's XE5620G simplifies integration of dial-up communications into embedded systems. It offers a single modem solution for use throughout the world, and its PLCC package allows the XE5620G to fit in the tightest system layout. It is a breakthrough for the embedded system designer.

The XE5620G offers unprecedented design flexibility. It offers a common communications solution for countries around the world, and the Hybrid PLCC package (HyPLCC™) is both the smallest complete modem and the only surface mount modem you can buy. The XE5620G fits a 68-Pin PLCC socket and therefore can be mounted in a socket or soldered onto the board. As the world's smallest complete modem, you can place the XE5620G where no other modem will fit.

The surface mount package and small size of the XE5620G are particularly impressive when you realize it is a complete modem. The DAA, RAM, ROM, Crystal; everything is included. The XE5620G even includes transferrable FCC Part 68 Registration. No further testing is required for US applications

Features

- * Small Size: The HyPLCC™ measures less than 1 inch by 1 inch square and 0.350 inches thick
- * Surface-mountable: The HyPLCC™ package is equivalent to a 68-Pin PLCC device.
- * Data transfer at all rates from 300 BPS to 56 KBPS using V.90, V.34bis, V.34, V.32bis, V.32, V.22bis, V.22, V.23, V.21, Bell 212A, and Bell 103 Protocols
- * Modem Control and Configuration via industry standard AT Commands.
- * Nonvolatile memory stores modem configuration and permits stored number dialing.
- * Incorporates Fax send and receive capabilities controlled by Class 1 Fax commands.
- * Complete integrated DAA includes, Ring Detect, Loop Current Holding Circuit, Hook Switch, Metallic Surge Protection, and Solid-State DAA
- * User Transferrable FCC Part 68 Registration (pending)
- * Compliant with telecom requirements around the world.
- * UL60950 Recognition (pending)
- * Low Power operation, 3.3 Volts, 300 milliwatt;

XE5620G BLOCK DIAGRAM

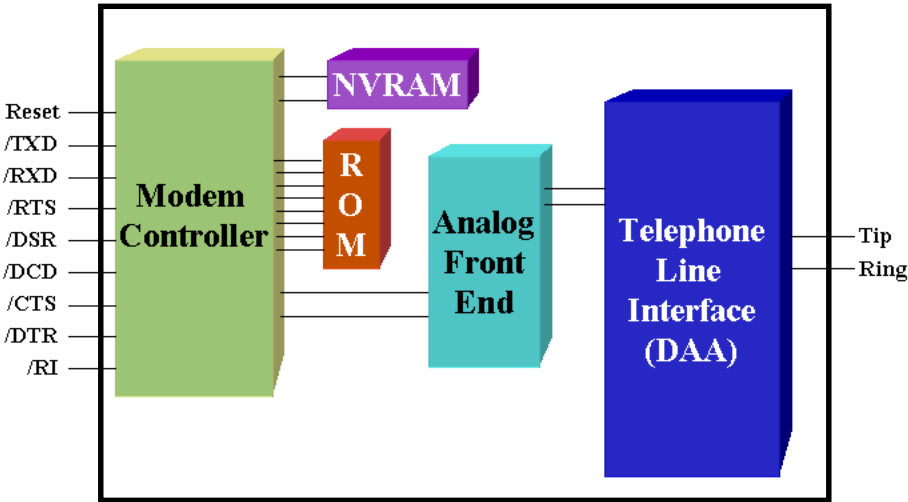

XE5620G Mechanical Specifications

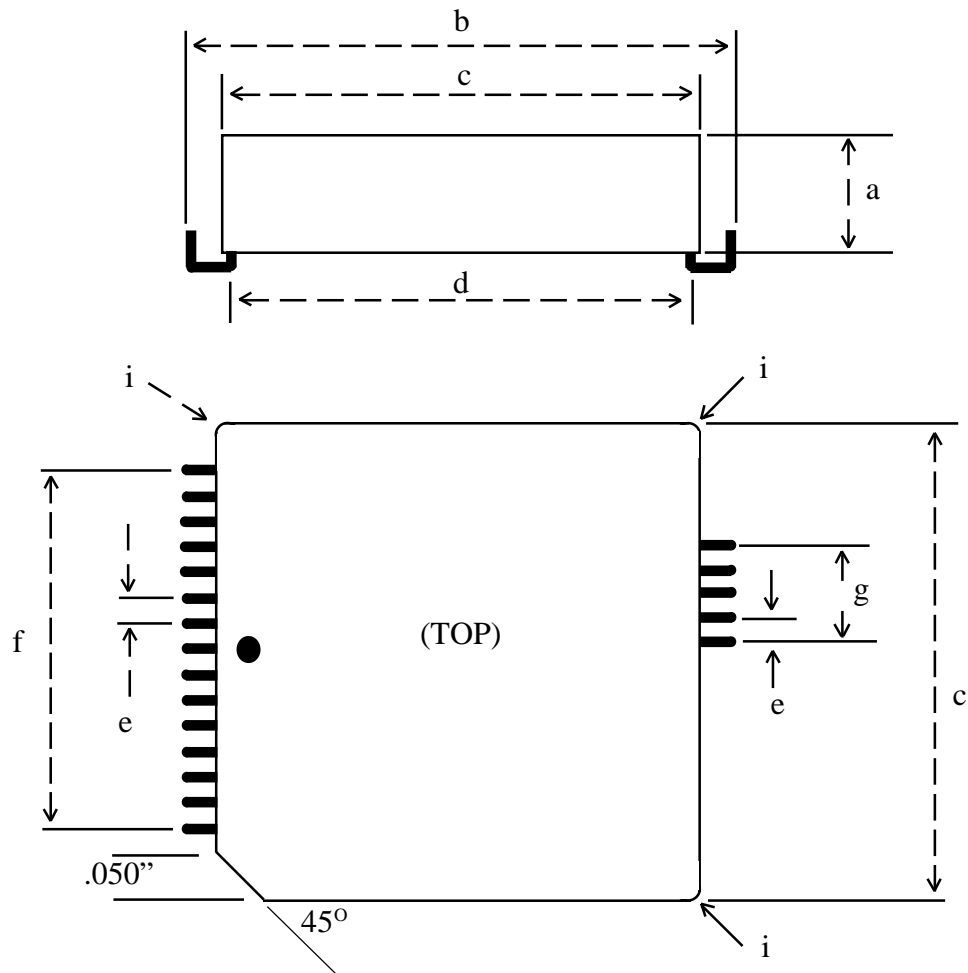

Dimension	Inches			Millimeters		
	Min	Typ	Max	Min	Typ	Max
a	0.345	0.350	0.355	8.76	8.89	9.02
b	0.985	0.990	0.995	25.02	25.15	25.27
c	0.950	0.955	0.960	24.13	24.26	24.38
d	0.910	0.920	0.930	23.11	23.37	23.62
e	0.045	0.050	0.055	1.15	1.27	1.40
f	0.695	0.700	0.705	17.65	17.78	17.91
g	0.195	0.200	0.205	10.03	10.16	10.29
i(radius)	0.015	0.020	0.025	0.13	0.25	0.38

XE5620G Pin Configuration

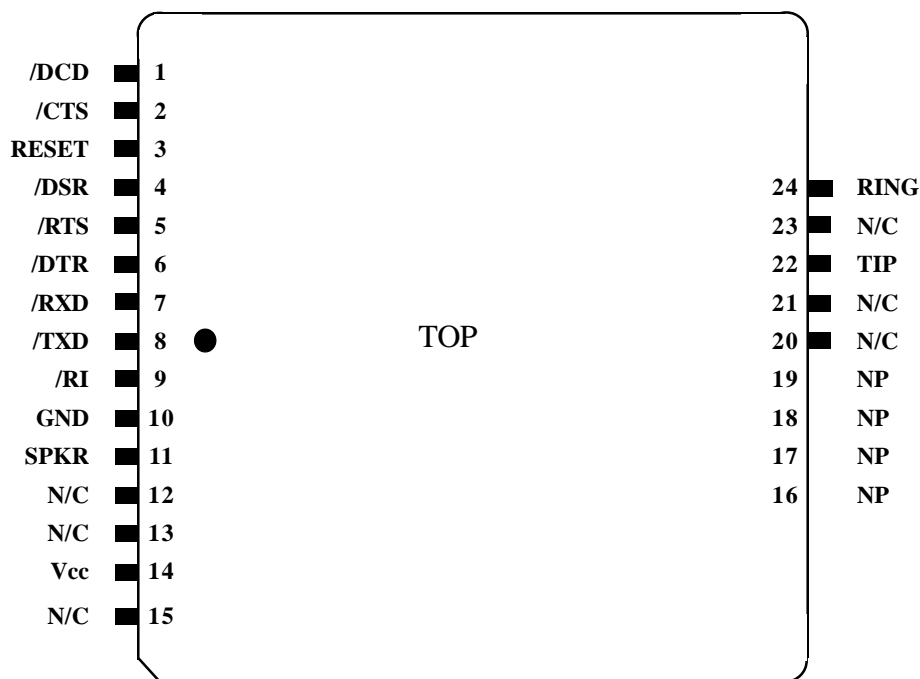

Pin Descriptions

PIN	NAME	DESCRIPTION
1	/DCD	/DCD is an active low output from the modem. It can be used to indicate the presence of a valid carrier signal. The AT&C command controls when the XE5620G asserts /DCD.
2	/CTS	/CTS is an active low output from the modem. When hardware flow control is active, the modem asserts /CTS to indicate that it can accept data from the terminal equipment on /TXD.
3	RESET	RESET is an active high input which initiates a modem hardware reset. RESET must be active for a minimum of 100 milliseconds for a proper modem reset sequence. No external reset is required; if none is used the RESET signal should be left open.
4	/DSR	/DSR is an active low output from the modem. /DSR can be used to indicate that the modem link is established. The AT&S command controls when the XE5620G asserts /DSR.
5	/RTS	/RTS is an active low input to the modem. When hardware flow control is active, /RTS indicates to the modem that the host has data to send.
6	/DTR	/DTR is an active low input to the modem. /DTR can be used to indicate that the terminal is available for communications. The AT&D command determines how the modem will interpret activity on /DTR.
7	/RXD	/RXD provides the path for received data and modem responses to be sent from the modem to the host terminal equipment.

XE5620G Pin Descriptions (continued)

PIN	NAME	DESCRIPTION
8	/TXD	/TXD provides the path for transmitted data and modem commands to be passed from the host terminal equipment to the modem.
9	/RI	The /RI signal reports on the presence of an incoming ring signal. When a ring occurs across Tip and Ring, the /RI output goes low and toggles with the cadence of the ring signal..
10	Ground	Ground provides the reference voltage for all host interface signals.
11	SPKR	SPKR allows connection of a speaker to monitor modem operations. SPKR cannot directly drive a speaker. An amplifier with a minimum input impedance of 300 ohms is required. The signal on SPKR is controlled by the ATL and ATM commands.
12-13	N/C	No internal connection
14	VCC	VCC provides 3.3 volt power to the modem.
15	N/C	No Internal Connection
16-19	NP	No Pin
20-21	N/C	No Internal Connection
22	Tip	<p>The Ring and Tip signals provide modem the connection to the telephone line. FCC Part 68 Rules require a 1500 volt isolation barrier between the telephone line and all other circuits. This isolation must be preserved throughout the system.</p> <p>The telephone company places a DC “Battery” voltage across Tip and Ring on all public switched telephone lines. The XE5620G will operate regardless of the polarity of this “Battery” voltage. The “Battery” voltage drives up to 100 milliamps of DC loop current.</p> <p>UL60950 requires minimum creepage and clearances distances be maintained between the Tip and Ring traces and all other circuits. Clearance is the shortest distance between conductive circuits; creepage is the distance between conductive surfaces along the surface</p>
23	N/C	No internal connection, To prevent damage in case of voltage surges on the telephone line, we recommend that nothing be connected to this pin.
24	Ring	<p>The Ring and Tip signals provide modem the connection to the telephone line. FCC Part 68 Rules require a 1500 volt isolation barrier between the telephone line and all other circuits. This isolation must be preserved throughout the system.</p> <p>The telephone company places a DC “Battery” voltage across Tip and Ring on all public switched telephone lines. The XE5620G will operate regardless of the polarity of this “Battery” voltage. The “Battery” voltage drives up to 100 milliamps of DC loop current.</p> <p>UL60950 requires minimum creepage and clearances distances be maintained between the Tip and Ring traces and all other circuits. Clearance is the shortest distance between conductive circuits; creepage is the distance between conductive surfaces along the surface.</p>

XE5620G Soldering Instructions

The XE5620G is subject to damage if over-exposed to heat during solder reflow operations. Following the soldering instructions below will ensure that the process of soldering the module to the board does not damage the modem. The XE5620G must not be exposed to direct Infrared (IR) heating. If your process includes direct IR heating, you must shield the XE5620G from the infrared rays.

Maximum Temperature	220° C
Maximum Time at 220° C	20 Seconds
Maximum Time above Eutectic (180° C)	90 Seconds
Maximum Preheat Dwell Time	180 Seconds

Maximum Recommended Solder Temperature Profile

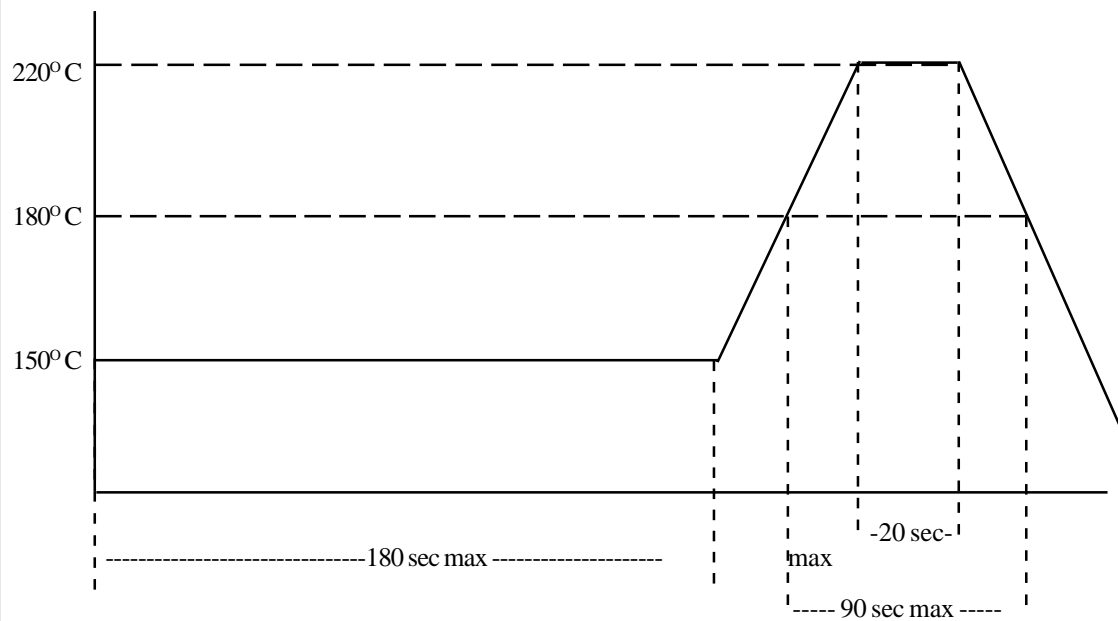

XE5620G Electrical Specifications

Parameter	Min	Typ	Max	Units	Comments
VCC	3.13	3.3	3.47	Volts	
ICC	85	90	100	ma	On Line
ICC		25		ma	On-Hook
Ring Voltage Detected	26		150	VRMS	Type B Ringer
Ring Frequency Detected	15.3		68	Hz	Type B Ringer
Telephone Loop Current	10	40	100	ma	
Line Impedance		600		Ohms	
Data Transmit level		-12.0	-9.0	dBm	
DTMF Transmit Level		-2.5	0	dBm	Avg over 3 second interval
Voh	2.4			Volts	
Vol			0.4	Volts	
Vih	2.0		VCC+0.3	Volts	
Vil	-0.3		0.8	Volts	

XE5620G ABSOLUTE MAXIMUM RATINGS

Storage Temperature	-25° C to +85° C
Operating Temperature Range ¹	0° C to +70° C
Maximum Time Above Eutectic (183° C)	90 seconds
Preheat Dwell Time	120 to 180 seconds
¹ The XE5620G can be ordered with an Operating Temperature of -40° C to +85° C at extra cost. Order XE5620G-ITR or to specify Industrial Temperature Range (ITR).	

XE5620G Typical Connection Diagram

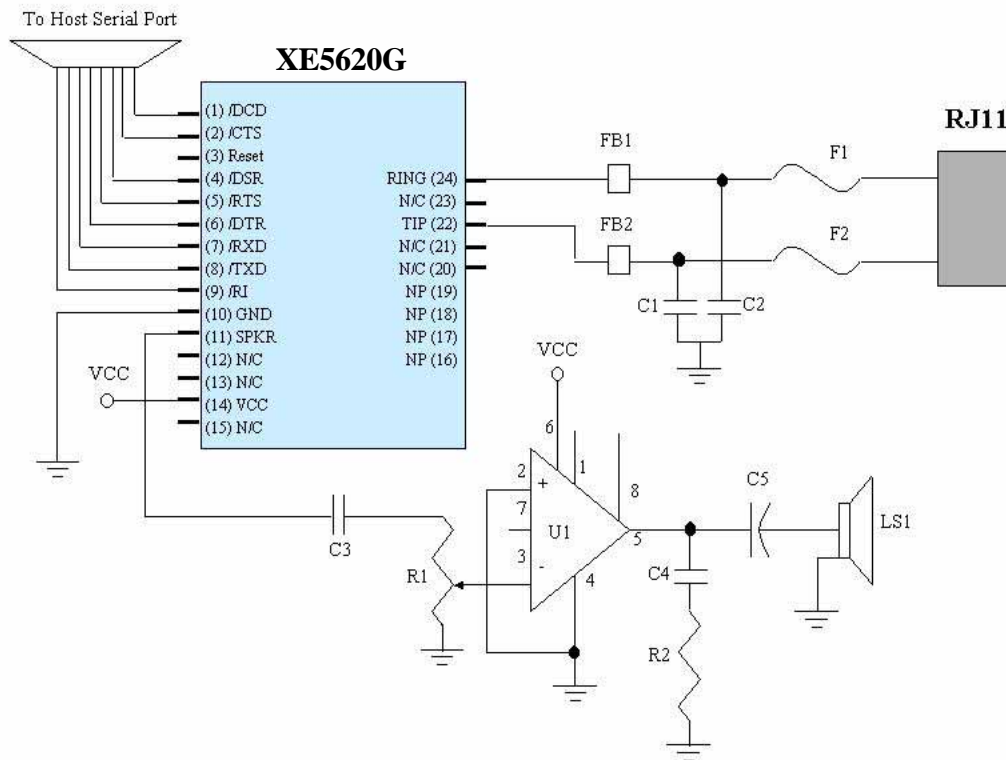

Parts List for XE5620G Typical Connection Diagram

Reference Designation	Qty	Description	Reference Designation	Qty	Description
C1, C2	2	Cap. 470 pfd 2600V	U1	1	National Semi LM386
C3, C4	2	Cap. 0.1 ufd 20% 16V	LS1	1	Speaker, 8 Ohms
C5	1	Cap. 100 ufd 20% 10V	R1	1	Potentiometer, 10K
FB1, FB2	2	Ferrite, TDK ACB2012L-120	R2	1	Resistor, 10 Ohms 20 %
F1, F2	2	PTC, TR600-150			

Notes:

- 1 FB1 and FB2 are ferrite beads which may be required for EMI filtering in your system. Without these components you may experience unintended radiation when the telephone cable is attached. We recommend selecting components such as the TDK ACB2012L-120 which provide a minimum of 100 ohms of impedance at frequencies above 100 MHz.
2. C1 and C2 are high-voltage capacitors which may be required for EMI filtering in your system. Without these components you may experience unintended radiation when the telephone cable is attached to your system. We recommend selecting components such as the Panasonic ECKDRS471. This 470 pfd, 3000 volt capacitor will direct the high frequency harmonics to the system ground. These capacitors must be rated at a minimum of 1500 volts to maintain the isolation required by FCC Part 68 Rules.
3. F1 and F2 are positive thermal coefficient (PTC) devices which protect the modem from excessive current flow. These devices are required for your system to pass UL60950. Fuses may be used in place of the PTC's

Application Note: Using a 68-Pin PLCC Socket

The XE5620G can be inserted into a socket for a 68-pin PLCC device. The HyPLCC package uses only 20 pins; 15 on one side and 5 on the opposite side. Alignment within the socket is critical for all pins of the XE5620G to make contact with the appropriate pins of the PLCC socket. The drawing below illustrates how the XE5620G can be inserted into the 68-pin PLCC socket. Emulation Technology's S-SMT-17-068-A socket is representative of sockets that can be used with the XE5620G.

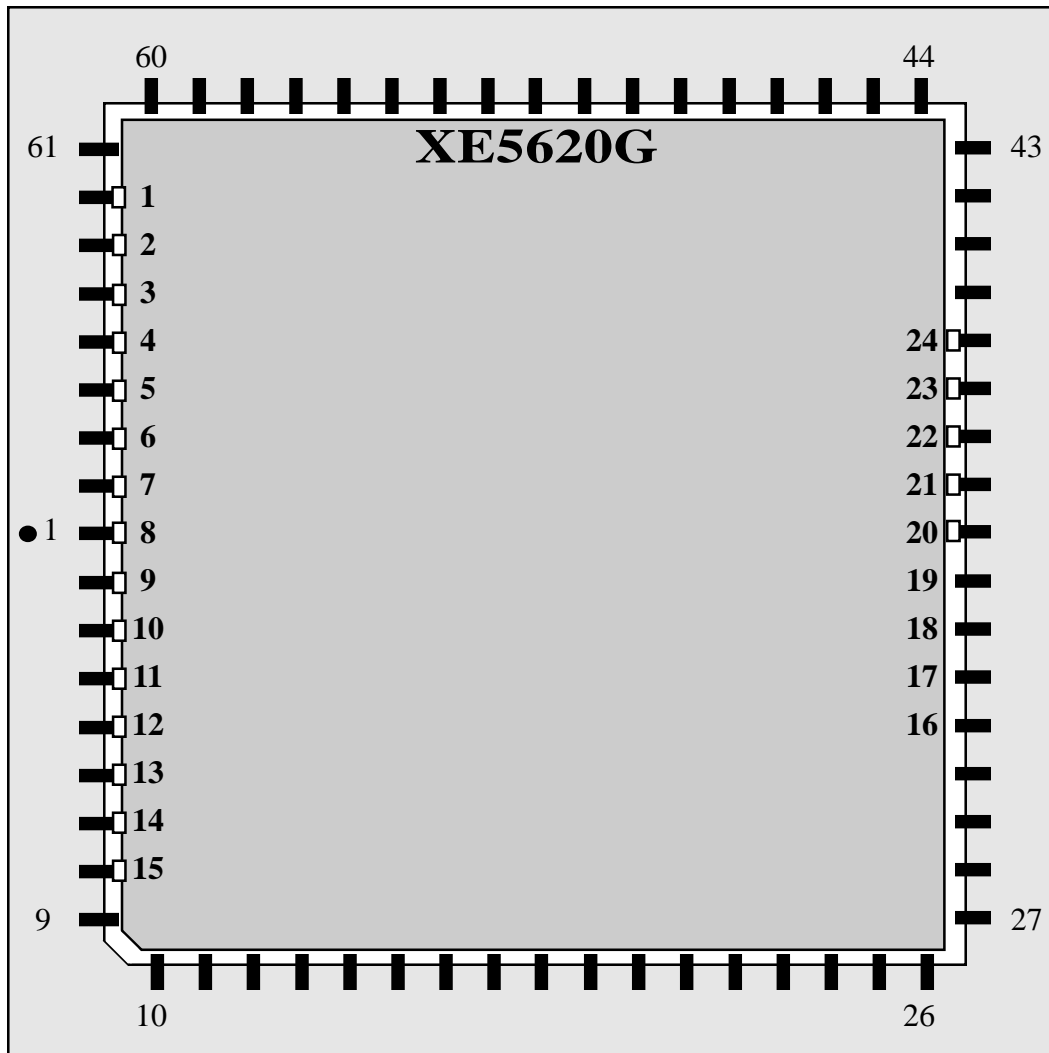

Country Selection

Xecom has designed the XE5620G to function in a wide variety of countries throughout the world. Below is a list of the available country configurations. Please contact Xecom if you have questions regarding a country not on this list.

Countries Supported:

<u>COUNTRY</u>	<u>AT COMMAND</u>	<u>COUNTRY</u>	<u>AT COMMAND</u>
Australia	AT*NC40	Lichtenstein	AT*NC29
Austria	AT*NC1	Luxembourg	AT*NC9
Belgium	AT*NC2	Namibia	AT*NC26
Czech Republic	AT*NC19	Norway	AT*NC11
Denmark	AT*NC3	Poland	AT*NC24
Finland	AT*NC4	Portugal	AT*NC12
France	AT*NC5	Russia	AT*NC25
Germany	AT*NC6	South Africa	AT*NC27
Greece	AT*NC17	Spain	AT*NC13
Holland	AT*NC10	Sweden	AT*NC14
Iceland	AT*NC28	Switzerland	AT*NC15
India	AT*NC18	Taiwan	AT*NC20
Ireland	AT*NC7	United Kingdom	AT*NC16
Italy	AT*NC8	United States	AT*NC22
Japan	AT*NC43		

NOTE: Country regulations permit Xecom to offer transferrable registration only in the United States, FCC Part 68 only. All other required certifications of systems using the XE5620G are the responsibility of Xecom's customer. Xecom will assist our customers with any of these certifications.

XE5620G AT Commands

The XE5620G uses "AT" commands for configuration and control. This section describes the AT command format and lists the AT commands, Registers and Result codes. XE5620G "AT" commands have two operational modes; Command Mode, Data Mode and FAX mode.

Data Mode: The XE5620G enters data mode after it connects to a remote modem and issues the appropriate result code. In the Data Mode the modem sends all data presented on Transmit Data (/TXD) to the remote modem and puts data from the remote modem onto Received Data (/RXD). When the modem exits data mode, it issues a "NO CARRIER" result code.

Command Mode: The XE5620G enters command mode on power-up, reset, a lost connection, or receipt of the escape code. In command mode the modem accepts commands from the host on transmit data. Appropriate result codes are returned on received data.

Fax Mode: The XE5620G enters Class 1 fax mode on receipt of AT+FCLASS=1. In fax mode commands and responses are issued at 19,200 bits per second; the character format is 8 bits no parity. The modem accepts fax commands only in fax mode. The A/, ATO, AT&T and escape commands are not valid in fax mode.

Command Line Format

Command lines issued to the modem follow a strict format. Each command begins with the prefix AT. The command buffer stores the command line and executes it upon receipt of a carriage return. Until executed, the command line can be edited with the backspace key.

Command Prefix - Each command, except the A/ command, begins with the AT prefix. The "A" and "T" may be both upper case or both lower case but cannot be of different cases. The prefix identifies the speed and parity of the commands sent to the modem. The modem determines data rate by measuring the width of the incoming bits. Parity is determined by comparing the parity bits of the "A" and the "T."

Command Line - Commands may be strung together in a single command line of up to 36 characters. Commands are executed in the sequence they appear. Spaces may be inserted into the command line but do not fill space in the command buffer. A carriage return terminates the command line and causes the commands to be executed. Register S3 allows the user to select a character other than a carriage return to terminate the command line.

Command Buffer - The Command Buffer holds a maximum of 36 characters, including the AT prefix. If the command buffer overflows, the modem issues an "ERROR" result code and commands are not executed.

Command Line Editing - The backspace edits a command line before it is executed. The backspace key, (Control and H simultaneously on some systems), erases the previous character in the command line. Register S5 allows the user to select a character other than a backspace to edit the command line.

Re-Execute Last Command - The A/ command causes the modem to re-execute the last command line. This is the only command which does not require the "AT" prefix.

Omitted Parameters - Most commands include a parameter which determines how the functions will be set. When the command parameter is omitted from the command string, it is assumed to be a 0.

Escape Characters - A 3 character escape sequence may be entered to switch the modem into command mode while on line. The escape character, set by Register S2, must be entered 3 times in succession to execute the escape. An AT command must then be entered within the period defined by S12 to enter command mode. The default escape sequence is "+++."

Result Codes - The modem issues a result code after each action. Result codes may be sent as full words, one or two digit numeric codes, or may be disabled all together. Each result code ends with a carriage return when numeric result codes are chosen. When full word result codes are chosen, a Line Feed and Carriage Return precede and follow each result code.

XE5620G AT Commands

An asterisk indicates the factory default

A - Answer Command -

Bn - Select Communications Standard

- n=0 Selects CCITT standards *
- n=1 Selects Bell standards

D - Dial Command -

- 0-9, A-D, #, * = Dialing Digits
- P = Pulse dial
- T = Tone dial
- W = Wait for dial tone
- , = Pause for the duration of S8
- @ = Wait for silence
- ! = Switch hook flash
- ; = Return to the command state
- ^ = Enable Calling Tone
- S=n = Dial Stored Number n

En - Command Echo

- n=0 Do not echo commands
- n=1 Enable command echo*

Hn - Switch Hook Control -

- n=0 Switch hook relay opens
- n=1 Switch hook relay closes

In - Modem Identification

Ln - Speaker Volume -

- n=0 Speaker volume low
- n=1 Speaker volume low
- n=2 Speaker volume medium *
- n=3 Speaker volume high.

Mn - Speaker Activity -

- n=0 Speaker off
- n=1 Speaker on until carrier received*
- n=2 Speaker remains on
- n=3 Speaker on after dialing until DCD detected.

Nn - Modulation Selection

- n=0 Communication Rate set by AT*I Command
- n=1 Automatic Negotiation of Data Rate beginning at AT*I Setting. *

On - On Line

- n=0 Return On Line with no retrain*
- n=1 Initiate retrain while returning On line.
- n=2 Initiate rate renegotiation while returning On line.

Qn - Responses

- n=0 Send responses *
- n=1 No Responses

Sr? - Interrogate Register -

Sr=n - Set Register Value -

Vn - Result Codes -

- n=0 Numeric Result Codes
- n=1 English Word Result Codes*

Wn - CONNECT Result Code -

- n=0 Display CONNECT DCE Speed
- n=1 Display CONNECT DTE Speed
- n=2 Display CONNECT DCE Speed plus error control extension *
- n=3 Display CONNECT DTE Speed plus error control extension

Xn - Result Code Set -

- n=0 Responses 0-4
- n=1 Responses 0-5 & 10
- n=2 Responses 0-6 & 10
- n=3 Responses 0-5, 7 & 10
- n=4 Responses 0-7 & 10*

Zn - Reset -

- n=0 Reset and Recall Profile 0 *
- n=1 Reset and Recall Profile 1

&Cn - DCD Operation

- n=0 DCD is forced active
- n=1 DCD indicates a valid carrier signal *

&Dn - DTR

- n=0 DTR is ignored
- n=1 When the modem is on-line DTR off switches it to the command mode and issues OK response.
- n=2 Modem disconnects if the host revokes DTR.*
- n=3 The modem performs a soft reset when DTR is revoked.

&F - Reset Factory Defaults

&Gn - Guard Timer -

- n=0 None *
- n=1 550 Hz Guard Timer
- n=2 1800 Hz Guard Timer

XE5620G AT Commands

&Kn - Flow Control

- n=0 No Flow Control
- n=3 RTS/CTS Flow Control *
- n=4 XON/XOFF Flow Control
- n=5 Transparent XON/XOFF Flow Control

&Pn - Pulse Dial Make/Break Ratio

- n=0 39%/61% 10 PPS *
- n=1 33%/67% 10 PPS
- n=2 39%/61% 20 PPS
- n=3 33%/67% 20 PPS

&Rn - Clear to Send

- n=0 Clear to Send follows Request to Send
- n=1 Clear to Send Active *

&Sn - Data Set Ready

- n=0 Data Set Ready Forced Active *
- n=1 Data Set Ready on at Start of Modem handshake

&Un - Protocol Selection

- n=0 V.90 *
- n=1 V.34Bis/V.34
- n=2 V.32bis/V.22bis
- n=3 Bell 103
- n=4 V.21
- n=5 V.23

&V - View Active Configuration

&Wn - Store Current Configuration

- n=0 Store Active Configuration in Profile 0 *
- n=1 Store Active Configuration in Profile 1

&Yn - Select Configuration to Recall

- n=0 Recall Configuration Profile 0 *
- n=1 Recall Configuration Profile 1

&Zn=x - Store dialing string x

%Cn - Data Compression Control

- n=0 No Data Compression
- n=1 Data Compression Enabled *

\Nn - Error Control Mode

- n=0 Normal Mode
- n=1 Direct Mode
- n=2 MNP Required
- n=3 MNP or Normal
- n=4 Auto Error Correction V.42 without ODP or ADP Phase Detection, MNP or Normal mode
- n=5 Auto Reliable Mode *
- n=6 V.42 without ODP or ADP Phase Detection required
- n=7 V.42 with ODP or ADP Phase Detection required

\Vn - Protocol Result Code

- n=0 No Protocol Result code added to Response *
- n=1 Protocol Result code added to Response

*Hn - Automatic Retrain

- n=0 Automatic Retrain Disabled
- n=1 Automatically retrain on poor signal quality

*In - Select Maximum Connection Speed

- n=0 1200 BPS,
- n=1 2400 BPS, 28,000 with AT&U=0
- n=2 4800 BPS, 29,333 with AT&U=0
- n=3 7200 BPS, 30,666 with AT&U=0
- n=4 9600 BPS, 32,000 with AT&U=0
- n=5 12,000 BPS, 33,333 with AT&U=0
- n=6 14,400 BPS, 34,666 with AT&U=0
- n=7 16,800 BPS, 36,000 with AT&U=0
- n=8 19,200 BPS, 37,333 with AT&U=0
- n=9 21,600 BPS, 38,666 with AT&U=0
- n=10 24,000 BPS, 40,000 with AT&U=0
- n=11 26,400 BPS, 41,333 with AT&U=0
- n=12 28,800 BPS, 42,666 with AT&U=0
- n=13 31,200 BPS, 44,000 with AT&U=0
- n=14 33,600 BPS *, 45,333 with AT&U=0
- n=15 46,666 BPS with AT&U=0

XE5620G AT Commands

n=16 48,000 BPS with AT&U=0
n=17 49,333 BPS with AT&U=0
n=18 50,666 BPS with AT&U=0
n=19 52,000 BPS with AT&U=0
n=20 53,333 BPS with AT&U=0
n=21 54,666 BPS with AT&U=0
n=22 56,000 BPS with AT&U=0 *

*Hn - Automatic Retrain

n=0 Automatic Retrain Disabled
n=1 Automatically retrain on poor signal quality *

*NCn - Country Configuration

n=1 Austria
n=2 Belgium
n=3 Denmark
n=4 Finland
n=5 France
n=6 Germany
n=7 Ireland
n=8 Italy
n=9 Luxembourg
n=10 Holland
n=11 Norway
n=12 Portugal
n=13 Spain
n=14 Sweden
n=15 Switzerland
n=16 United Kingdom
n=17 Greece
n=18 India
n=19 Czech Republic
n=20 Taiwan
n=21 reserved
n=22 United States
n=23 reserved
n=24 Poland
n=25 Russia
n=26 Namibia
n=27 South Africa
n=28 Iceland
n=29 Liechtenstein

n=30 reserved
n=31 reserved
n=32 reserved
n=33 reserved
n=34 reserved
n=35 reserved
n=36 reserved
n=37 reserved
n=38 reserved
n=39 reserved
n=40 Australia

*On - Transmit Level Selection (Note: This feature is not available in all country configurations.)

n=0 -11 dBm (default)
n=1 -12 dBm
n=2 -13 dBm
n=3 -14 dBm
n=4 -15 dBm
n=5 -16 dBm
n=6 -17 dBm
n=7 -18 dBm
n=8 -19 dBm
n=9 -20 dBm
n=10 -21 dBm
n=11 -22 dBm
n=12 -23 dBm
n=13 -24 dBm
n=14 -25 dBm
n=15 -26 dBm

XE5620G AT Class 1 FAX Commands

AT+FCLASS? - Service Class Indication

- 0 = Configured as a data modem
- 1 = Configured for Service Class 1.

AT+FCLASS=? - Service Class Capability

- 0 = Configured as a data modem
- 1 = Configured for Service Class 1.

AT+FCLASS=n - Set Service Class

- 0 = Configured as a data modem
- 1 = Configured for Service Class 1.

AT+FAE=n - Data/Fax Auto Answer

- 0 = Answer as a fax modem only
- 1 = Either a fax or data modem

AT+FLO - Flow Control

- 0 = Flow Control Off
- 1 = XON/XOFF Flow Control Selected
- 2 = RTS/CTS Flow Control Selected

AT+FRH<mod> - Receive HDLC Data

- 3 V.21 Channel 2, 300 bps
- 24 V.27ter, 2400 bps
- 48 V.27ter, 4800 bps
- 72 V.29, 7200 bps
- 96 V.29, 9600 bps
- 97 V.17, 9600 bps
- 98 V.17 short train, 9600 bps
- 121 V.17, 12,000 bps
- 122 V.17 short train, 12,000 bps
- 145 V.17, 14,400 bps
- 146 V.17 short train, 14,400 bps

AT+FRM<mod> - Receive Fax

(see AT+FRH for "mod" values)

AT+FRS<time> - Receive Silence

AT+FRTn - Receive Test Data

AT+FTH<mod> - Transmit HDLC Data

(see AT+FRH for "mod" values)

AT+FTM<mod> - Transmit Fax

(see AT+FRH for "mod" values)

AT+FTS<time> - Transmit Silence

AT+FTTn - Transmit Test Data

XE5620G Modem Registers

<p>S0 Answer on nth Ring: S0 sets the modem to automatically answer on the nth ring. Setting S0 to 0 disables automatic answer.</p> <p>Range: 0 to 255 Units Rings Default 0</p>	<p>S7 Wait for Carrier after Dialing: S7 determines how long the modem waits for a valid carrier signal after dialing.</p> <p>Range: 1 to 255 Units Seconds Default 60</p>									
<p>S1 Ring Count: S1 is a read-only register showing the number of rings detected. If a ring is not detected within 8 seconds, S1 is reset to zero.</p> <p>Range: 0 to 255 Units Rings Default 0</p>	<p>S8 Comma Pause Time: S8 defines the duration of the pause initiated by a comma in the dialing string. The pause is generally used when waiting for a second dial tone.</p> <p>Range: 1 to 255 Units Seconds Default 2</p>									
<p>S2 Escape Character: S2 determines the ASCII escape character. Values of 0-127 select valid characters; values from 128 to 255 disable the escape sequence.</p> <p>Range: 0 to 255 Units ASCII Character Default 43 (+)</p>	<p>S9 Carrier Detect Response Time: S9 establishes the length of time the remote modem's carrier must be present to be recognized as valid.</p> <p>Range: 1 to 255 Units 0.1 Seconds Default 6</p>									
<p>S3 Line Termination Character: S3 determines the ASCII character which will terminate commands and modem responses.</p> <p>Range: 0 to 127 Units ASCII Character Default 13 (Carriage Return)</p>	<p>S10 Carrier Off Disconnect Delay: S10 selects how long carrier must be lost before the modem disconnects. Note: If S10 is smaller than the value of S9 or S10 is set to 255, the modem will not automatically disconnect on loss of carrier.</p> <p>Range: 1 to 255 Units 0.1 Seconds Default 14</p>									
<p>S4 Line Feed Character: S4 sets the ASCII character to act as a line feed character in modem responses.</p> <p>Range: 0 to 127 Units ASCII Character Default 10 (Line Feed)</p>	<p>S11 Tone Dialing Speed: S11 sets the duration and spacing of the dialing tones. S11 does not affect the pulse dialing.</p> <p>Range: 50 to 255 Units 1 Millisecond Default 95</p>									
<p>S5 Backspace Character: S5 defines the ASCII character used as a backspace to edit the command line.</p> <p>Range: 0 to 127 Units ASCII Character Default 8 (Back Space)</p>	<p>S12 Escape Code Guard Timer: S12 sets the escape sequence guard timer. If characters are received before or after the escape sequence, within the guard timer, the modem aborts the escape attempt and remains in data mode.</p> <p>Range: 0 to 255 Units 0.02 Seconds Default 50</p>									
<p>S6 Dial Tone Wait Time: S6 determines how long the modem waits for dial tone before dialing. The Dial Tone Wait Time cannot be set to less than two seconds.</p> <p>Range: 3 to 7 Units Seconds Default 6</p>	<p>S13 Pulse Dialing : S13 permits pulse dialing to be disabled</p> <table border="0" style="margin-left: 20px;"> <thead> <tr> <th style="text-align: left;"><u>Register</u></th> <th style="text-align: left;"><u>Setting</u></th> <th style="text-align: left;"><u>Function</u></th> </tr> </thead> <tbody> <tr> <td></td> <td>0</td> <td>No Pulse Dialing</td> </tr> <tr> <td></td> <td>1</td> <td>Pulse Dialing Allowed</td> </tr> </tbody> </table>	<u>Register</u>	<u>Setting</u>	<u>Function</u>		0	No Pulse Dialing		1	Pulse Dialing Allowed
<u>Register</u>	<u>Setting</u>	<u>Function</u>								
	0	No Pulse Dialing								
	1	Pulse Dialing Allowed								

XE5620G Modem Registers (continued)

<p>S14 Bit-mapped Register: S14 stores the values of Several AT Commands.</p> <table border="0" style="width: 100%;"> <thead> <tr> <th style="text-align: left;"><u>Bit</u></th> <th style="text-align: left;"><u>Function</u></th> </tr> </thead> <tbody> <tr><td>0</td><td>Echo (ATE0)</td></tr> <tr><td>1</td><td>Reserved</td></tr> <tr><td>2</td><td>Result Codes (ATQ0)</td></tr> <tr><td>3</td><td>Numeric Responses (ATV0)</td></tr> <tr><td>4,5</td><td>Pulse Dialing Parameters (AT&P0)</td></tr> </tbody> </table>	<u>Bit</u>	<u>Function</u>	0	Echo (ATE0)	1	Reserved	2	Result Codes (ATQ0)	3	Numeric Responses (ATV0)	4,5	Pulse Dialing Parameters (AT&P0)	<p>S45 Sleep Mode Timer: S45 determines how long the modem will remain inactive before entering the low power sleep mode.</p> <p>Range: 0, 5-255 Units Seconds Default 0</p>								
<u>Bit</u>	<u>Function</u>																				
0	Echo (ATE0)																				
1	Reserved																				
2	Result Codes (ATQ0)																				
3	Numeric Responses (ATV0)																				
4,5	Pulse Dialing Parameters (AT&P0)																				
<p>S21 Bit-mapped Register: S21 stores the values of Several AT Commands.</p> <table border="0" style="width: 100%;"> <thead> <tr> <th style="text-align: left;"><u>Bit</u></th> <th style="text-align: left;"><u>Function</u></th> </tr> </thead> <tbody> <tr><td>0-2</td><td>Reserved</td></tr> <tr><td>3,4</td><td>DTR Condition (AT&D)</td></tr> <tr><td>5</td><td>DCD Function (AT&C)</td></tr> <tr><td>6</td><td>DSR Function (AT&S)</td></tr> <tr><td>7</td><td>Reserved</td></tr> </tbody> </table>	<u>Bit</u>	<u>Function</u>	0-2	Reserved	3,4	DTR Condition (AT&D)	5	DCD Function (AT&C)	6	DSR Function (AT&S)	7	Reserved	<p>S95 Bit-mapped Register: S95 stores the modem's result code and modulation information.</p> <table border="0" style="width: 100%;"> <thead> <tr> <th style="text-align: left;"><u>Bit</u></th> <th style="text-align: left;"><u>Function</u></th> </tr> </thead> <tbody> <tr><td>0, 1, 2</td><td>Result Code Selection</td></tr> <tr><td>3</td><td>Modulation Selection</td></tr> <tr><td>4-7</td><td>Reserved</td></tr> </tbody> </table>	<u>Bit</u>	<u>Function</u>	0, 1, 2	Result Code Selection	3	Modulation Selection	4-7	Reserved
<u>Bit</u>	<u>Function</u>																				
0-2	Reserved																				
3,4	DTR Condition (AT&D)																				
5	DCD Function (AT&C)																				
6	DSR Function (AT&S)																				
7	Reserved																				
<u>Bit</u>	<u>Function</u>																				
0, 1, 2	Result Code Selection																				
3	Modulation Selection																				
4-7	Reserved																				
<p>S22 Bit-mapped Register: S22 stores the values of Several AT Commands.</p> <table border="0" style="width: 100%;"> <thead> <tr> <th style="text-align: left;"><u>Bit</u></th> <th style="text-align: left;"><u>Function</u></th> </tr> </thead> <tbody> <tr><td>0-3</td><td>Speaker Control (ATL/ATM)</td></tr> <tr><td>4,5,6</td><td>Response Set (ATX)</td></tr> <tr><td>7</td><td>Reserved</td></tr> </tbody> </table>	<u>Bit</u>	<u>Function</u>	0-3	Speaker Control (ATL/ATM)	4,5,6	Response Set (ATX)	7	Reserved	<p>S97 Bit-mapped Register: S97 stores the modem's error control and data compression information.</p> <table border="0" style="width: 100%;"> <thead> <tr> <th style="text-align: left;"><u>Bit</u></th> <th style="text-align: left;"><u>Function</u></th> </tr> </thead> <tbody> <tr><td>0-2</td><td>Error Correction Selection</td></tr> <tr><td>3-6</td><td>Reserved</td></tr> <tr><td>7</td><td>Data Compression Selection</td></tr> </tbody> </table>	<u>Bit</u>	<u>Function</u>	0-2	Error Correction Selection	3-6	Reserved	7	Data Compression Selection				
<u>Bit</u>	<u>Function</u>																				
0-3	Speaker Control (ATL/ATM)																				
4,5,6	Response Set (ATX)																				
7	Reserved																				
<u>Bit</u>	<u>Function</u>																				
0-2	Error Correction Selection																				
3-6	Reserved																				
7	Data Compression Selection																				
<p>S23 Bit-mapped Register: S23 stores the modem's active data format.</p> <table border="0" style="width: 100%;"> <thead> <tr> <th style="text-align: left;"><u>Bit</u></th> <th style="text-align: left;"><u>Function</u></th> </tr> </thead> <tbody> <tr><td>0, 1,2,3</td><td>DTE Rate 0-300 BPS</td></tr> <tr><td>4,5</td><td>Parity</td></tr> <tr><td>6,7</td><td>Reserved</td></tr> </tbody> </table>	<u>Bit</u>	<u>Function</u>	0, 1,2,3	DTE Rate 0-300 BPS	4,5	Parity	6,7	Reserved	<p>S98 Bit-mapped Register: S98 stores the automatic retrain and Flow control status.</p> <table border="0" style="width: 100%;"> <thead> <tr> <th style="text-align: left;"><u>Bit</u></th> <th style="text-align: left;"><u>Function</u></th> </tr> </thead> <tbody> <tr><td>0, 1</td><td>Error Correction Selection</td></tr> <tr><td>2, 3</td><td>Reserved</td></tr> <tr><td>4-6</td><td>Flow Control Selection</td></tr> <tr><td>7</td><td>Reserved</td></tr> </tbody> </table>	<u>Bit</u>	<u>Function</u>	0, 1	Error Correction Selection	2, 3	Reserved	4-6	Flow Control Selection	7	Reserved		
<u>Bit</u>	<u>Function</u>																				
0, 1,2,3	DTE Rate 0-300 BPS																				
4,5	Parity																				
6,7	Reserved																				
<u>Bit</u>	<u>Function</u>																				
0, 1	Error Correction Selection																				
2, 3	Reserved																				
4-6	Flow Control Selection																				
7	Reserved																				
<p>S30 Inactivity Timer: S30 determines how long the modem will remain on line with not data flowing. A 0 in this register disables the inactivity time out.</p> <p>Range: 0-255 Units Minutes Default 0</p>																					

XE5620G Modem Responses

<u>Digits</u>	<u>Verbose</u>	<u>Description</u>	<u>Digits</u>	<u>Verbose</u>	<u>Description</u>
0	OK	Command Successful	30	CONNECT 26400	26,400 BPS Connection
1	CONNECT	300 bps connection	31	CONNECT 28800	28,800 BPS Connection
2	RING	Ring signal detected	32	CONNECT 31200	31,200 BPS Connection
3	NO CARRIER	Carrier not detected	33	CONNECT 33600	33,600 BPS Connection
4	ERROR	Error in command line	34	CONNECT 28000	V.90 28,000 BPS Connection
5	CONNECT 1200	1200BPS Connection	35	CONNECT 29333	V.90 29,333 BPS Connection
6	NO DIAL TONE	No dial tone detected	36	CONNECT 30666	V.90 30,666 BPS Connection
7	BUSY	Busy signal detected	37	CONNECT 32000	V.90 32,000 BPS Connection
8	NO ANSWER	No 5 sec. silence detected	38	CONNECT 33333	V.90 33,333 BPS Connection
9	CONNECT 300	300 BPS Connection	39	CONNECT 34666	V.90 34,666 BPS Connection
10	CONNECT 2400	2400 BPS Connection	40	CONNECT 36000	V.90 36,000 BPS Connection
11	CONNECT 4800	4800 BPS Connection	41	CONNECT 37333	V.90 37,333 BPS Connection
12	CONNECT 9600	9600 BPS Connection	42	CONNECT 38666	V.90 38,666 BPS Connection
13	CONNECT 7200	7200 BPS Connection	43	CONNECT 40000	V.90 40,000 BPS Connection
14	CONNECT 12000	12,000 BPS Connection	44	CONNECT 41333	V.90 41,333 BPS Connection
15	CONNECT 16800	16,800 BPS Connection	45	CONNECT 42666	V.90 42,666 BPS Connection
16	CONNECT 19200	19,200 BPS Connection	46	CONNECT 44000	V.90 44,000 BPS Connection
17	CONNECT 21600	21,600 BPS Connection	47	CONNECT 45333	V.90 45,333 BPS Connection
20	CONNECT 14400	14,400 BPS Connection	48	CONNECT 46666	V.90 46,666 BPS Connection
21	CONNECT 24000	24,000 BPS Connection	49	CONNECT 48000	V.90 48,000 BPS Connection
22	CONNECT 38400	38,400 BPS Connection	50	CONNECT 49333	V.90 49,333 BPS Connection
23	CONNECT 57600	57,600 BPS Connection	51	CONNECT 50666	V.90 50,666 BPS Connection
24	CONNECT 115200	115,200 BPS Connection	52	CONNECT 52000	V.90 52,000 BPS Connection
25	CONNECT1200TX/75RX	V.23 Connection 1200 BPS Transmit 75 BPS Receive	53	CONNECT 53333	V.90 53,333 BPS Connection
26	CONNECT75TX/1200RX	V.23 Connection 75 BPS Transmit 1200BPS Receive	54	CONNECT 54666	V.90 54,666 BPS Connection
28	CONNECT BELL 300	Bell 300 BPS Connection	55	CONNECT 56000	V.90 56,000 BPS Connection
29	CONNECT V21	V21 300 BPS Connection			

FCC Instructions

The XE5620G complies with part 68 of the FCC Rules and Regulations. With each device shipped, there is a label which contains, among other information, the FCC Registration Number and Ringer Equivalence Number (REN) for this product. You must, upon request, provide this information to your telephone company.

The mounting of this device in the final assembly must be made in such a manner as to preserve the high voltage protection between the TIP/RING Connection and the rest of the system. Typically, this may be accomplished by maintaining a minimum spacing 100 mils between the TIP/RING Traces to the RJ-11C Jack and low voltage portion of the system. No additional circuitry may be attached between TIP/RING and the telephone line connection, unless specifically allowed in the rules.

The REN is useful to determine the quantity of devices you may connect to a telephone line and still have all of these devices ring when the number is called. In most, but not all areas, the sum of the RENs of all devices connected to one line should not exceed five (5.0). To be certain of the number of devices you may connect to the line, as determined by the REN, you should contact the local telephone company to determine the maximum REN for you calling area.

If your system causes harm to the telephone network, the telephone company may discontinue service temporarily. If possible, they will notify you in advance. If advance notification is not practical, you will be notified as soon as possible.

Your telephone company may make changes in its facilities, equipment, operations or procedures that could affect proper functioning of your equipment. If they do, you will be notified in advance to give you an opportunity to maintain uninterrupted telephone service.

If you experience trouble with this device, please contact XECOM at (408) 945-6640 for information on obtaining service or repairs. The telephone company may ask you to disconnect this device from the network until the problem has been corrected or until you are sure that the device is not malfunctioning.

The device may not be used on coin service lines provided by the telephone company (this does not apply to private coin telephone applications which use standard telephone lines). Connection to party lines is subject to state tariffs.

Terms of Sale

Devices sold by XECOM are covered by the warranty provisions appearing in its Terms of Sale only. XECOM makes no warranty, express, statutory, implied, or by description regarding the information set forth herein, or regarding the freedom of the described devices from patent infringement. XECOM makes no warranty of merchantability or fitness for any purposes. XECOM reserves the right to discontinue production and change specifications and prices at any time and without notice. This product is intended for use in normal commercial applications. Applications requiring extended temperature range, unusual environmental requirements, or high reliability applications, such as military, medical life-support or life-sustaining equipment, are specifically not recommended without additional processing and authorization by XECOM for such application.

Xecom assumes no responsibility for the use of any circuitry other than circuitry embodied in a Xecom product. No other circuits, patents, or licenses are implied.

Life Support Policy

Xecom's products are not authorized for use as Critical Components in Life Support Devices or Systems.

Life Support Devices or Systems are devices or systems which, (a) are intended for surgical implant into the body, or (b) support or sustain life, and whose failure to perform, when properly used in accordance with instructions provided in the labeling, can be reasonably expected to result in significant injury to the user.

A Critical Component is any component of a life support device or system whose failure to perform can be reasonably expected to cause failure of the life support device or system, or to affect its safety or effectiveness.

Copyright, Xecom © 2002

While Xecom, Inc. has made every effort to ensure that the information presented here is accurate, Xecom will not be liable for any damages arising from errors or omission of fact. Xecom reserves the right to modify specifications and/or prices without notice. Product mentioned herein are used for identification purposes only and may be trademarks and/or registered trademarks of their respective companies.

xecom[®]

Xecom Incorporated
374 Turquoise Street, Milpitas, CA 95035
Ph:408-945-6640 Fax:408-942-1346 E-Mail: info@xecom.com