



Photoelectric sensors  
W9L-3, Through-beam photoelectric sensor

WSE9L-3P1137



**Type** > [WSE9L-3P1137](#)  
**Part No.** > [1058915](#)



*Illustration may differ*

**At a glance**

- Tough VISTAL™ housing
- Precise laser light spot
- Laser class 1
- Teach-in
- Optimized SICK ASIC technology
- Connections: M8 and M12 plugs, cable as well as cable with plug
- M3 hole pattern

**Your benefits**

- Precise detection of small objects and object features
- Detection of objects even through small openings
- Less machine downtime thanks to the stable VISTAL™ housing
- The longest sensing ranges in its class
- Wide range of connection options
- Multiple mounting options
- Highly visible light spot simplifies alignment



**Features**

Sensor/detection principle:	Through-beam photoelectric sensor
Dimensions (W x H x D):	12.2 mm x 50 mm x 23.6 mm
Housing design (light emission):	Rectangular
Mounting hole:	M3
Sensing range max.:	0 m ... 60 m
Sensing range:	0 m ... 50 m
Type of light:	Visible red light
Light source:	Laser <sup>1)</sup>
Laser class:	1, 1 (IEC 60825-1/CDRH 21 CFR 1040.10 & 1040.11)
Adjustment:	Single teach-in button
Light spot size (distance):	Ø 1 mm (500 mm)

<sup>1)</sup> Average service life 50,000 h at T<sub>A</sub> = +25 °C

**Mechanics/electronics**

Supply voltage:	10 V DC ... 30 V DC <sup>1)</sup>
Ripple:	< 5 V <sub>pp</sub> <sup>2)</sup>
Power consumption:	≤ 30 mA <sup>3)</sup>

Output type:	PNP <sup>4)</sup>
Output function:	Complementary
Switching mode:	Light/dark switching <sup>5)</sup>
Output current I <sub>max.</sub> :	≤ 100 mA
Response time:	≤ 0.5 ms <sup>6)</sup>
Switching frequency:	1,000 Hz <sup>7)</sup>
Connection type:	Cable, 4-wire, 2 m <sup>8)</sup>
Cable material:	PVC
Conductor cross-section:	0.14 mm <sup>2</sup>
Circuit protection:::	A, B, C <sup>9)</sup> <sup>10)</sup> <sup>11)</sup>
Protection class:	III
Weight:	80 g
Optics material:	PMMA
Enclosure rating:	IP 66 IP 67 IP 69K
Ambient operating temperature:	-10 °C ... +50 °C
Ambient storage temperature:	-30 °C ... +70 °C
Ambient operating temperature extended:::	-30 °C ... +55 °C <sup>12)</sup> <sup>13)</sup>
UL File No.:	NRKH.E181493
Housing material:	Plastic, VISTAL

<sup>1)</sup> Limit values, operation in short-circuit protected network max. 8 A <sup>2)</sup> May not exceed or fall short of  $V_S$  tolerances <sup>3)</sup> Without load <sup>4) 5)</sup> Q = light-switching <sup>6)</sup> Signal transit time with resistive load <sup>7)</sup> With light/dark ratio 1:1 <sup>8)</sup> Do not bend below 0 °C <sup>9)</sup> A =  $V_S$  connections reverse-polarity protected <sup>10)</sup> B = inputs and output reverse-polarity protected <sup>11)</sup> C = interference suppression <sup>12)</sup> As of  $T_a = 50$  °C, a max. supply voltage  $V_{max.} = 24$  V and a max. load current  $I_{max.} = 50$  mA is permitted <sup>13)</sup> Using the sensor below  $T_a = -10$  °C is possible, if the sensor is turned on at  $T_a > -10$  °C, then the environment cools down and the sensor is not disconnected from the supply voltage during the whole time. It is not allowed to turn on the sensor below  $T_a = -10$  °C

## Dimensional drawing

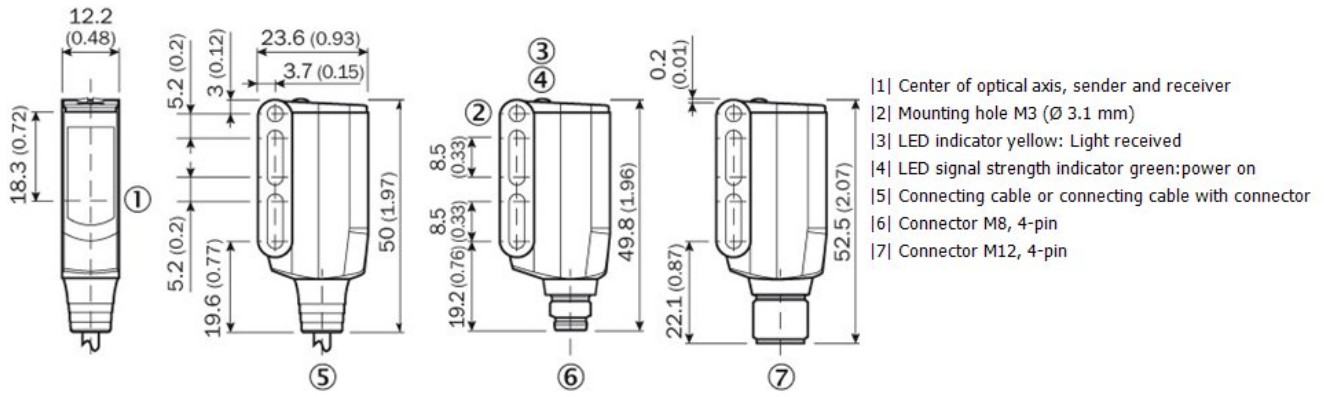

## Adjustments possible

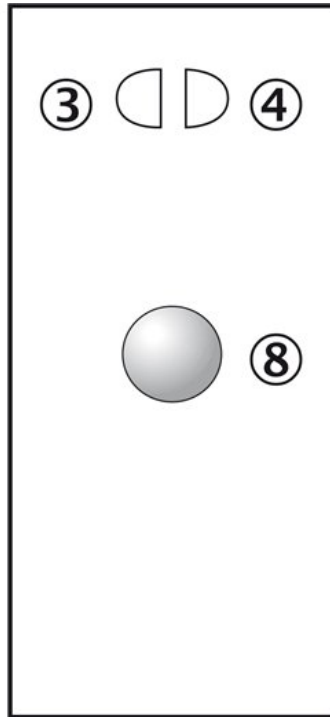

- |3| LED indicator yellow: Light received
- |4| LED signal strength indicator green:power on
- |8| Teach-in button

Connection diagram

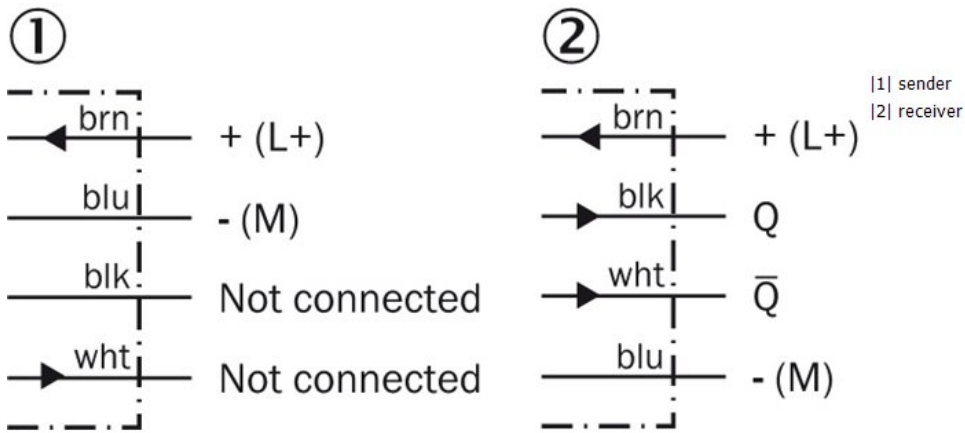

Characteristic curve

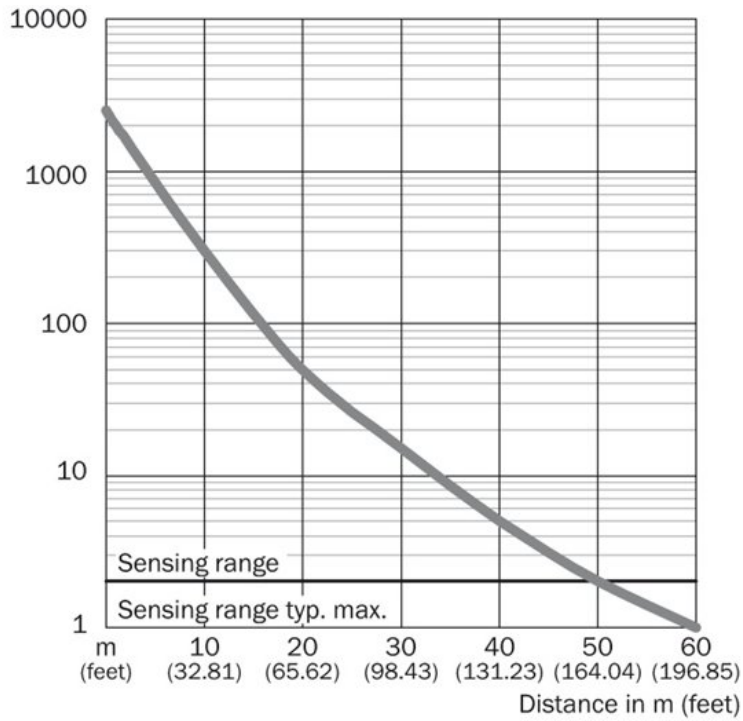

**Light spot size**

Radius in mm (inch)

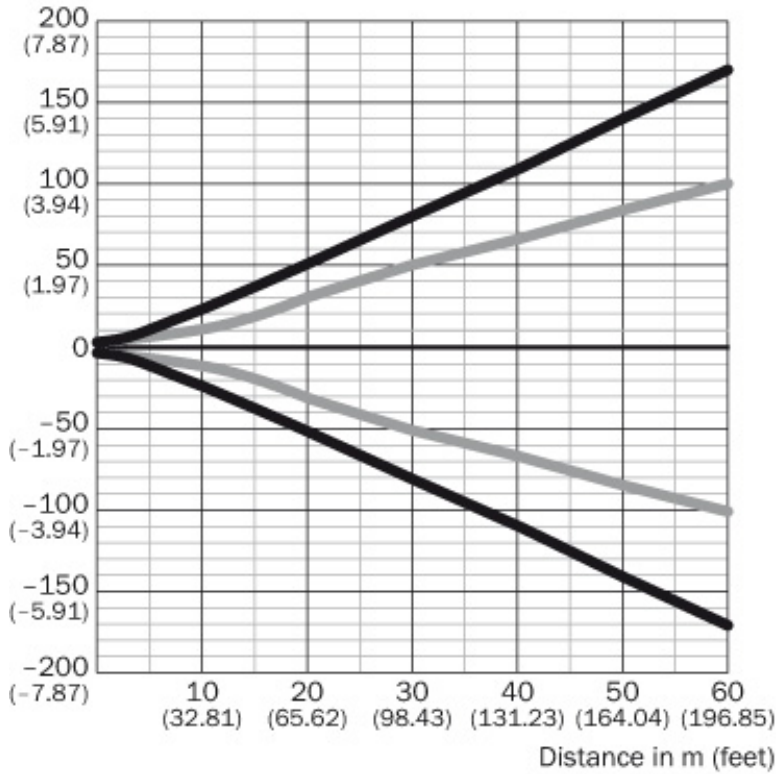

**Dimensions in mm (inch)**

Sensing range	Vertical	Horizontal
<b>0.5 m</b> (1.64 feet)	< 1.0 (0.04)	< 1.0 (0.04)
<b>1 m</b> (3.28 feet)	1.5 (0.06)	1.2 (0.05)
<b>5 m</b> (16.40 feet)	15 (0.59)	11 (0.43)
<b>10 m</b> (32.81 feet)	45 (1.77)	28 (1.10)
<b>60 m</b> (196.85 feet)	336 (13.23)	200 (7.87)

Vertical  
 Horizontal

**Sensing range diagram**

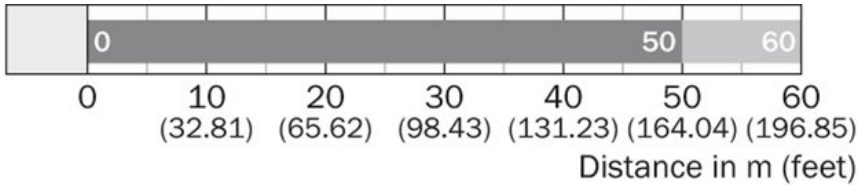

Sensing range     
  Sensing range typ. max.

## Lichtfleckgröße (Detailansicht)

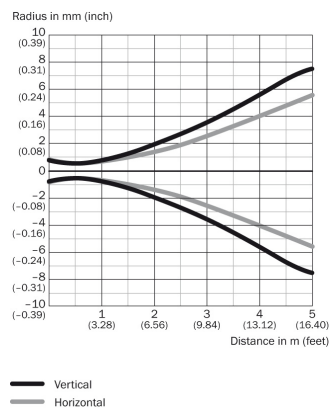

**Australia**

Phone +61 3 9457 0600  
1800 33 48 02 – tollfree  
E-Mail sales@sick.com.au

**Belgium/Luxembourg**

Phone +32 (0)2 466 55 66  
E-Mail info@sick.be

**Brasil**

Phone +55 11 3215-4900  
E-Mail marketing@sick.com.br

**Canada**

Phone +1 905 771 14 44  
E-Mail information@sick.com

**Česká republika**

Phone +420 2 57 91 18 50  
E-Mail sick@sick.cz

**China**

Phone +86 4000 121 000  
E-Mail info.china@sick.net.cn  
Phone +852-2153 6300  
E-Mail ghk@sick.com.hk

**Danmark**

Phone +45 45 82 64 00  
E-Mail sick@sick.dk

**Deutschland**

Phone +49 211 5301-301  
E-Mail info@sick.de

**España**

Phone +34 93 480 31 00  
E-Mail info@sick.es

**France**

Phone +33 1 64 62 35 00  
E-Mail info@sick.fr

**Great Britain**

Phone +44 (0)1727 831121  
E-Mail info@sick.co.uk

**India**

Phone +91-22-4033 8333  
E-Mail info@sick-india.com

**Israel**

Phone +972-4-6881000  
E-Mail info@sick-sensors.com

**Italia**

Phone +39 02 27 43 41  
E-Mail info@sick.it

**Japan**

Phone +81 (0)3 5309 2112  
E-Mail support@sick.jp

**Magyarország**

Phone +36 1 371 2680  
E-Mail office@sick.hu

**Nederland**

Phone +31 (0)30 229 25 44  
E-Mail info@sick.nl

**Norge**

Phone +47 67 81 50 00  
E-Mail sick@sick.no

**Österreich**

Phone +43 (0)22 36 62 28 8-0  
E-Mail office@sick.at

**Polska**

Phone +48 22 837 40 50  
E-Mail info@sick.pl

**România**

Phone +40 356 171 120  
E-Mail office@sick.ro

**Russia**

Phone +7-495-775-05-30  
E-Mail info@sick.ru

**Schweiz**

Phone +41 41 619 29 39  
E-Mail contact@sick.ch

**Singapore**

Phone +65 6744 3732  
E-Mail sales.gsg@sick.com

**Slovenija**

Phone +386 (0)1-47 69 990  
E-Mail office@sick.si

**South Africa**

Phone +27 11 472 3733  
E-Mail info@sickautomation.co.za

**South Korea**

Phone +82 2 786 6321/4  
E-Mail info@sickkorea.net

**Suomi**

Phone +358-9-25 15 800  
E-Mail sick@sick.fi

**Sverige**

Phone +46 10 110 10 00  
E-Mail info@sick.se

**Taiwan**

Phone +886 2 2375-6288  
E-Mail sales@sick.com.tw

**Türkiye**

Phone +90 (216) 528 50 00  
E-Mail info@sick.com.tr

**United Arab Emirates**

Phone +971 (0) 4 88 65 878  
E-Mail info@sick.ae

**USA/México**

Phone +1(952) 941-6780  
1 (800) 325-7425 – tollfree  
E-Mail info@sickusa.com

More representatives and agencies  
at [www.sick.com](http://www.sick.com)