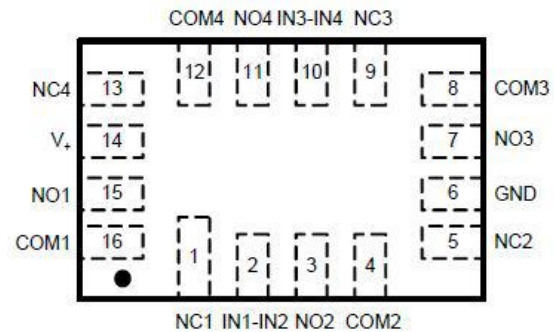
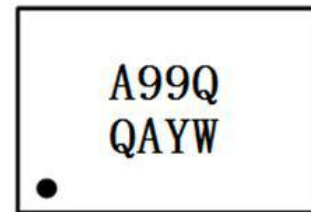

WAS4799Q
Low On Resistance, Quad SPDT Analog Switch
[Http://www.willsemi.com](http://www.willsemi.com)
Descriptions

The WAS4799Q is a high performance, quad, Single Pole Double Throw (SPDT) analog switch that features ultra-low Ron of 0.5 Ω (typical) at 3.0V VCC. The WAS4799Q operates over a wide VCC range of 2.3V to 4.5V and is designed for break-before-make operation. The select input is TTL-level compatible.

WAS4799Q is also featured with smart circuitry to minimize VCC leakage current even when the control voltage is lower than VCC supply voltage. This feature suits mobile handset applications by allowing direct interface with baseband processor general-purpose IO with minimal battery consumption. In other word, there is no need of additional device to shift control level to be the same as that of VCC in real application.

The WAS4799Q is available in QFN1.8x2.6-16L package. Standard Products are Pb-free and halogen-free.

Pin configuration (Top view)

Features

- Supply voltage : 2.3 ~ 4.5V
- ultra-low On Resistance : 0.5 Ω
- -3dB Bandwidth : 40MHz
- Rail-to-Rail Signal Range
- Break-Before-Make Switching
- Low quiescent current over an Expanded Control Input Range

- A99Q** = Device code
- QA** = Special code
- Y** = Year code
- W** = Week code

Marking
Applications

- Cell phones, PDA, Digital Camera and Notebook
- LCD Monitor, TV and Set-Top Box
- Audio and Video Signal Routing
- Other electronics equipments

Order information

Device	Package	Shipping
WAS4799Q-16/TR	QFN1.8x2.6-16L	3000/Reel&Tape

Pin descriptions

Pin Number	Symbol	Descriptions
4,8,12,16	COMX	Common Data Port
1,5,9,13	NCX	Data Port(Normally closed)
3,7,11,15	NOX	Data Port(Normally open)
2,10	A0,A1	Logic Input Control
14	VCC	Positive Power Supply
6	GND	Ground

Note: X=1 or 2,3,4

Function descriptions

A0	Function
0	NC1 Connected to COM1, NC2 Connected to COM2
1	NO1 Connected to COM1, NO2 Connected to COM2

A1	Function
0	NC3 Connected to COM3, NC4 Connected to COM4
1	NO3 Connected to COM3, NO4 Connected to COM4

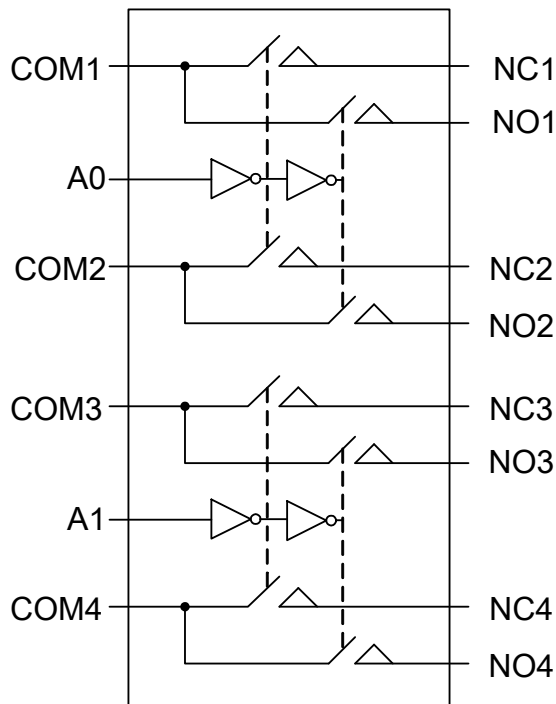
Functional Block Diagram

Absolute Maximum Ratings ⁽¹⁾

Parameter	Symbol	Value	Unit
Supply Voltage	V_{CC}	-0.3 ~ 6.5	V
Control Input Voltage	V_{IN}	-0.3 ~ 6.5	V
DC Input Voltage ⁽²⁾	V_{INPUT}	-0.3 ~ 6.5	V
Continuous Current NO_NC_COM_		±300	mA
Peak Current NO_NC_COM_ (pulsed at 1ms 50% duty cycle)		±400	mA
Peak Current NO_NC_COM_ (pulsed at 1ms 10% duty cycle)		±500	mA
Storage Temperature Range	T_{STG}	-65 ~ 150	°C
Junction Temperature under Bias	T_J	150	°C
Lead Temperature (Soldering, 10 seconds)	T_L	260	°C
Power Dissipation	P_D	250	mW

Recommend operating ratings ⁽³⁾

Parameter	Symbol	Value	Unit
Supply Voltage Operating	V_{CC}	2.3 ~ 4.5	V
Control Input Voltage	V_{IN}	0.0 ~ V_{CC}	V
Input Signal Voltage	V_{IS}	0.0 ~ V_{CC}	V
Operating Temperature	T_A	-40 ~ 85	°C
Input Raise and Fall Time(Control Input V_{CC} =2.3~3.6V)	t_r, t_f	0 ~ 10	ns/V
Thermal Resistance	$R_{\theta JA}$	350	°C/W

Note:

1. “Absolute Maximum Ratings” may cause permanent damage to the device. This is a stress only rating and operation of the device at these or any other conditions beyond those indicated in the operational sections of this specification is not implied.
2. The input and output negative voltage ratings may be exceeded if the input and output diode current ratings are observed.
3. Control input must be held high or Low, it must not float.

DC Electronics Characteristics (Ta=25°C, VCC=4.5V, unless otherwise noted)

Parameter	Symbol	Conditions	Min.	Typ.	Max.	Unit
Input logic high level	V _{IH}	VCC: 3.0 ~ 4.5	1.6			V
		VCC: 2.3 ~ 3.0	1.4			V
Input logic low level	V _{IL}	VCC: 3.0 ~ 4.5			0.6	V
		VCC: 2.3 ~ 3.0			0.4	V
Supply quiescent current	I _{CC}	I _{OUT} =0, V _{IN} =0 or V _{IN} =VCC			1.0	μA
Increase in I _{CC} per input	I _{CC(T)}	I _{OUT} =0, VCC=4.5 V _{IN} >1.8 or V _{IN} <0.5			2.0	μA
Input leakage current	I _{IN}	V _{SEL} =VCC			±1.0	μA
Off state switch leakage current	I _{OFF}				±1.0	μA
On state switch leakage current	I _{ON}				±1.0	μA
On-Resistance	R _{ON}	VCC=4.5V, V _{IS} =0~4.5V, I _{ON} =100mA,		0.5		Ω
		VCC=3.0V, V _{IS} =0~3.0V, I _{OUT} =100mA,		0.6		Ω
On-Resistance Matching Between Channels	Δ R _{ON}	VCC=4.5V, V _{IS} =0.8V, I _{OUT} =100mA,		0.08		Ω
		VCC=3.0V, V _{IS} =0.8V, I _{OUT} =100mA,		0.12		Ω
On-Resistance Flatness	R _{FLAT(ON)}	VCC=4.5V, V _{IS} =0~4.5V, I _{OUT} =100mA,			0.2	Ω
		VCC=3.0V, V _{IS} =0~3.0V, I _{OUT} =100mA,			0.2	Ω

AC Electronics Characteristics (Ta=25°C, VCC=4.5V, unless otherwise noted)

Parameter	Symbol	Conditions	Min.	Typ.	Max.	Unit
Turn-On Time	T _{ON}	VCC=4.5V, V _{IS} =1.5V, C _L =35pF, R _L =50Ω		200		ns
Turn-Off Time	T _{OFF}	VCC=4.5V, V _{IS} =1.5V, C _L =35pF, R _L =50Ω		200		ns
Break-Before-Make time	T _{BBM}	Generate by design		100		ns
-3dB Bandwidth	BW	R _L =50Ω, C _L =0pF		40		MHz
Off isolation (Per Channel)	OIRR	F=100KHz, R _L =50Ω		-50		dB
Crosstalk (Channel to Channel)	Xtalk	F=100KHz, R _L =50Ω		-50		dB
Total Harmonic Distortion	THD	F=20Hz to 20KHz R _L =32Ω, V _{IS} =2Vp-p		0.02		%

Capacitance (Ta=25°C unless otherwise noted)

Parameter	Symbol	Conditions	Min.	Typ.	Max.	Unit
Off capacitance	C _{OFF}	F=1MHz, VCC=3.3V		50		pF
On capacitance	C _{ON}	F=1MHz, VCC=3.3V		135		pF

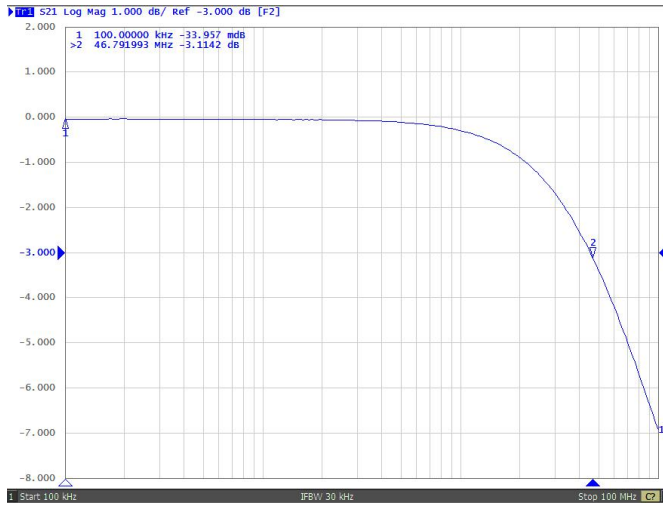
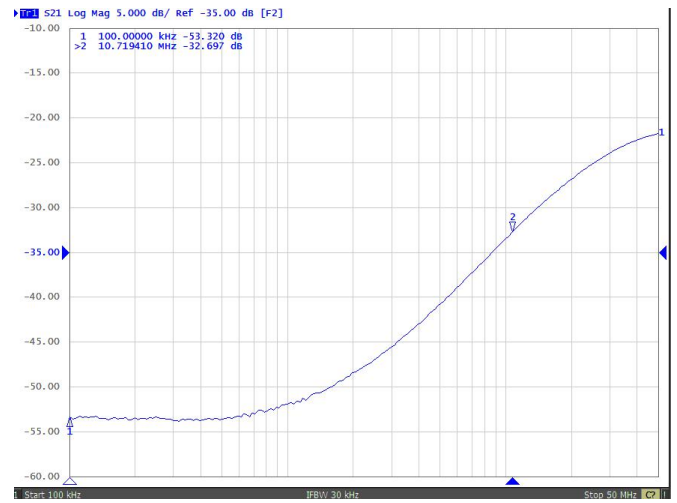
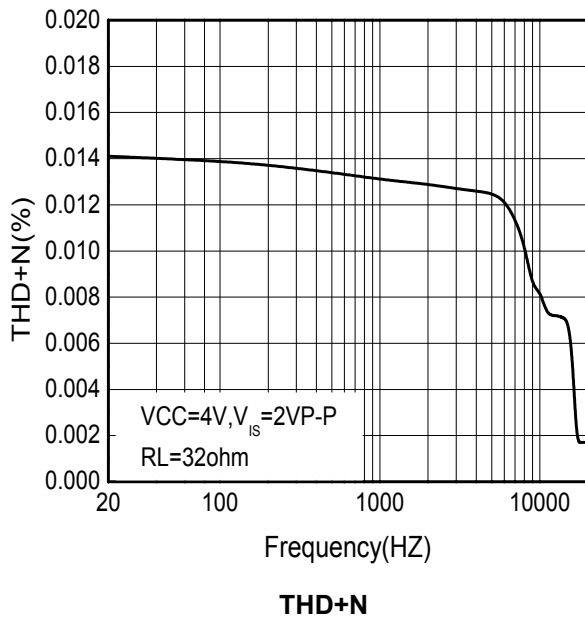
Typical Characteristics (Ta=25°C, VCC=4.0V, unless otherwise noted)

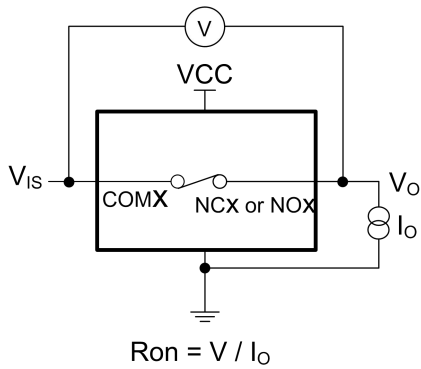
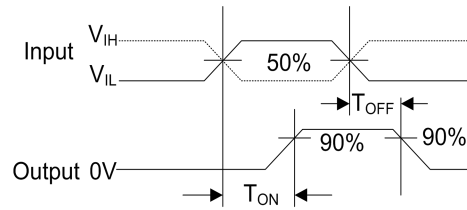
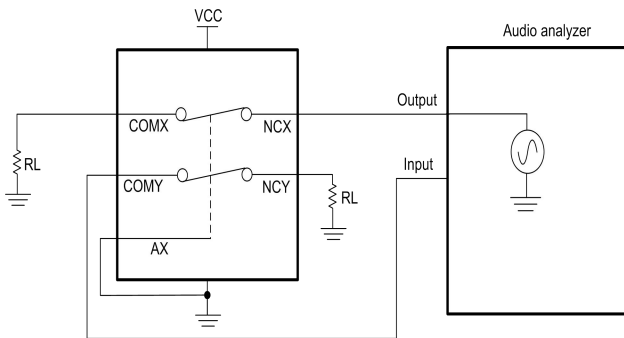
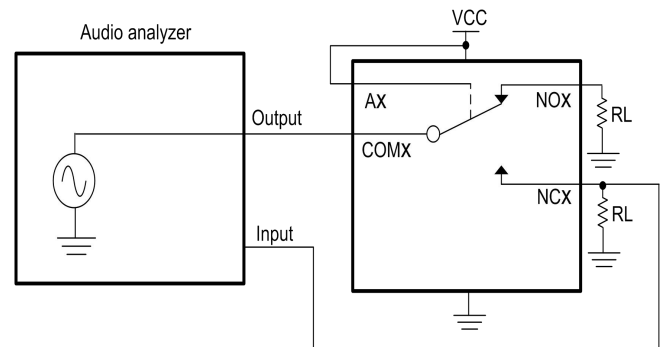
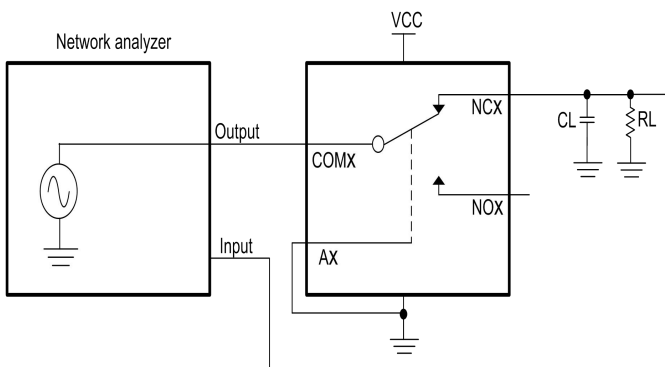
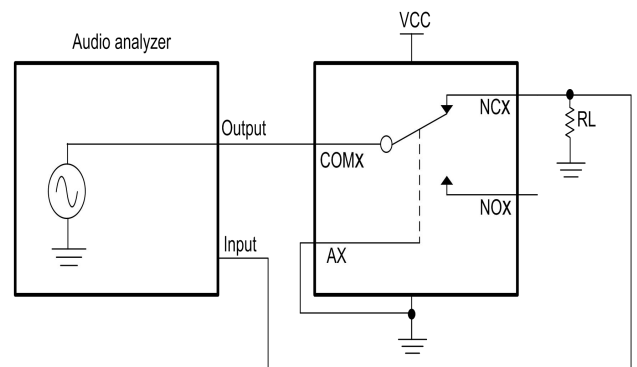
Bandwidth (BW)

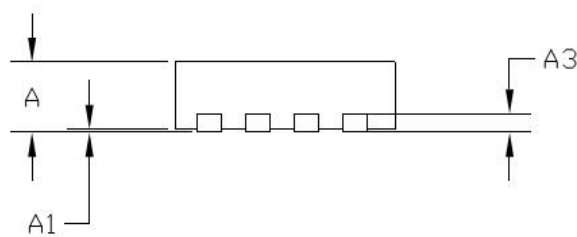
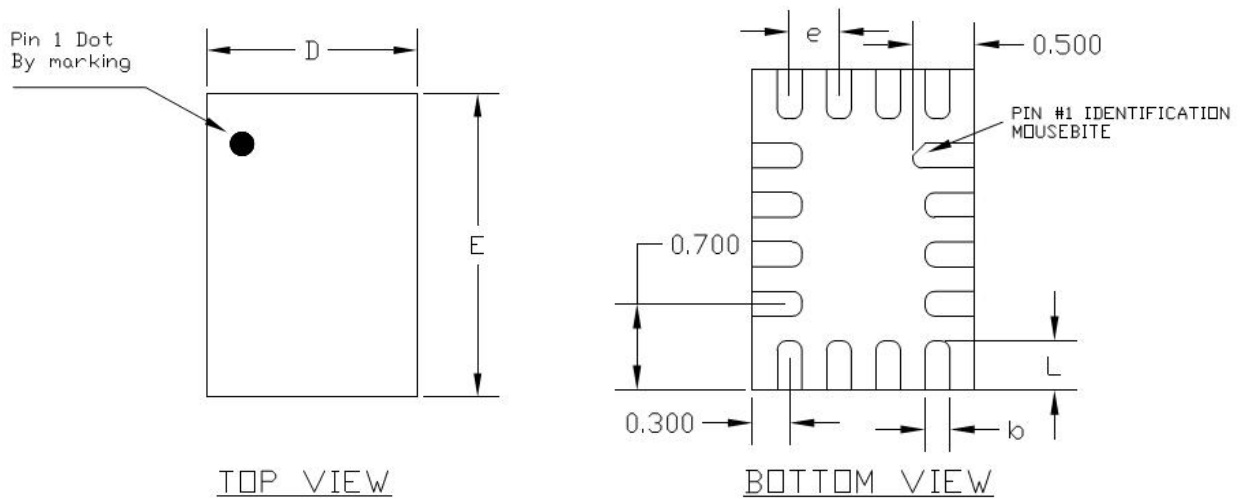
Off Isolation

Test Circuits

ON-Resistance (R_{ON})

ON/OFF Time Waveforms (T_{ON} / T_{OFF})

Crosstalk (X_{talk})

Off isolation ($OIRR$)

Bandwidth (BW)

THD+N

Package outline dimensions
QFN1826-16L

SIDE VIEW

Symbol	Dimension in Millimeters		
	Min.	Typ.	Max.
A	0.50	0.55	0.60
A1	0.00	-	0.05
A3	0.15 Typ.		
D	1.75	1.80	1.85
E	2.55	2.60	2.65
L	0.30	0.40	0.50
b	0.15	0.20	0.25
e	0.40 Typ.		