

isc N-Channel MOSFET Transistor

W15NK90Z

• FEATURES

- With TO-247 packaging
- With low gate drive requirements
- Easy to drive
- 100% avalanche tested
- Minimum Lot-to-Lot variations for robust device performance and reliable operation

• APPLICATIONS

- Switching applications

• ABSOLUTE MAXIMUM RATINGS(T_a=25°C)

| SYMBOL | PARAMETER | VALUE | UNIT |
|------------------|--|-----------|------|
| V _{DSS} | Drain-Source Voltage | 900 | V |
| V _{GSS} | Gate-Source Voltage | ±30 | V |
| I _D | Drain Current-Continuous@T _c =25°C T _c =100°C | 15 9.5 | A |
| I _{DM} | Drain Current-Single Pulsed | 60 | A |
| P _D | Total Dissipation | 350 | W |
| T _j | Operating Junction Temperature | -55~150 | °C |
| T _{stg} | Storage Temperature | -55~150 | °C |

• THERMAL CHARACTERISTICS

| SYMBOL | PARAMETER | MAX | UNIT |
|-----------------------|------------------------------------|-----|------|
| R _{th(ch-c)} | Channel-to-case thermal resistance | 0.7 | °C/W |

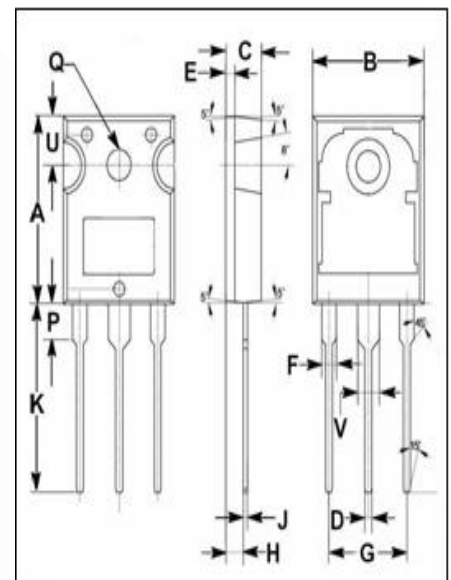
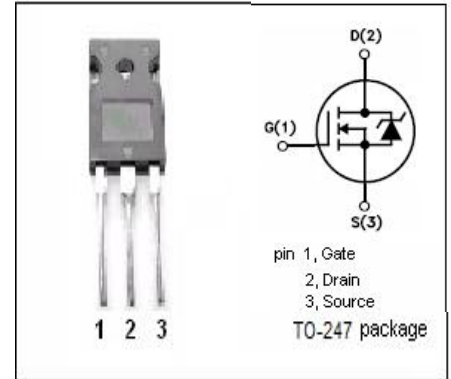

| DIM | mm | |
|-----|-------|-------|
| | MIN | MAX |
| A | 19.80 | 20.20 |
| B | 15.40 | 15.80 |
| C | 4.90 | 5.10 |
| D | 0.90 | 1.10 |
| E | 1.40 | 1.60 |
| F | 1.90 | 2.10 |
| G | 10.80 | 11.00 |
| H | 2.40 | 2.60 |
| J | 0.50 | 0.70 |
| K | 19.50 | 20.50 |
| P | 3.90 | 4.10 |
| Q | 3.30 | 3.50 |
| U | 5.20 | 5.40 |
| V | 2.90 | 3.10 |

isc N-Channel MOSFET Transistor

W15NK90Z

ELECTRICAL CHARACTERISTICS

T_c=25°C unless otherwise specified

| SYMBOL | PARAMETER | CONDITIONS | MIN | TYP | MAX | UNIT |
|---------------------|--------------------------------|--|-----|-----|---------|------|
| BV _{DSS} | Drain-Source Breakdown Voltage | V _{GS} =0V; I _D = 1.0mA | 900 | | | V |
| V _{GS(th)} | Gate Threshold Voltage | V _{DS} =V _{GS} ; I _D =0.15mA | 3.0 | | 4.5 | V |
| R _{DS(on)} | Drain-Source On-Resistance | V _{GS} = 10V; I _D =7.5A | | 400 | 550 | mΩ |
| I _{GSS} | Gate-Source Leakage Current | V _{GS} = ±20V; V _{DS} = 0V | | | ±0.1 | μA |
| I _{DSS} | Drain-Source Leakage Current | V _{DS} = 900V; V _{GS} = 0V; @T _c =25°C V _{DS} = 900V; V _{GS} = 0V; T _c =125°C | | | 1 50 | μA |
| V _{SDF} | Diode forward voltage | I _{SD} =15A, V _{GS} = 0 V | | | 1.6 | V |