

Features

- High-performance CMOS non-volatile static RAM 32768 x 8 bits
- 25, 35 and 45 ns Access Times
- 10, 15 and 20 ns Output Enable Access Times
- Software STORE Initiation
- Automatic STORE Timing
- 10⁵ STORE cycles to EEPROM
- 10 years data retention in EEPROM
- Automatic RECALL on Power Up
- Software RECALL Initiation
- Unlimited RECALL cycles from EEPROM
- Unlimited Read and Write to SRAM
- Single 5 V ± 10 % Operation
- Operating temperature range
0 to 70 °C
-40 to 85 °C
- CECC 90000 Quality Standard
- ESD characterization according MIL STD 883C M3015.7-HBM (classification see IC Code Numbers)
- Packages: PDIP28 (300 mil)
PDIP28 (600 mil)
SOP28 (330 mil)

Description

The U631H256 has two separate modes of operation: SRAM mode and nonvolatile mode. In SRAM mode, the memory operates as an ordinary static RAM. In nonvolatile operation, data is transferred in parallel from SRAM to EEPROM or from EEPROM to SRAM. In this mode SRAM functions are disabled.

The U631H256 is a fast static RAM (25, 35, 45 ns), with a nonvolatile electrically erasable PROM (EEPROM) element incorporated in each static memory cell. The SRAM can be read and written an unlimited number of times, while independent nonvolatile data resides in EEPROM. Data transfers from the SRAM to the EEPROM (the STORE operation), or from the EEPROM to the SRAM (the RECALL operation) are initiated through software sequences.

The U631H256 combines the high performance and ease of use of a fast SRAM with nonvolatile data integrity.

Once a STORE cycle is initiated, further input or output are disabled until the cycle is completed.

Because a sequence of addresses is used for STORE initiation, it is important that no other read or write accesses intervene in the sequence or the sequence will be aborted.

Internally, RECALL is a two step procedure. First, the SRAM data is cleared and second, the nonvolatile information is transferred into the SRAM cells.

The RECALL operation in no way alters the data in the EEPROM cells. The nonvolatile data can be recalled an unlimited number of times.

The U631H256 is pin compatible with standard SRAMs.

Pin Configuration

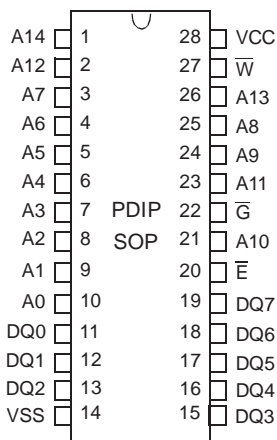

Top View

Pin Description

Signal Name	Signal Description
A0 - A14	Address Inputs
DQ0 - DQ7	Data In/Out
\bar{E}	Chip Enable
\bar{A}	Output Enable
\bar{W}	Write Enable
VCC	Power Supply Voltage
VSS	Ground

Block Diagram

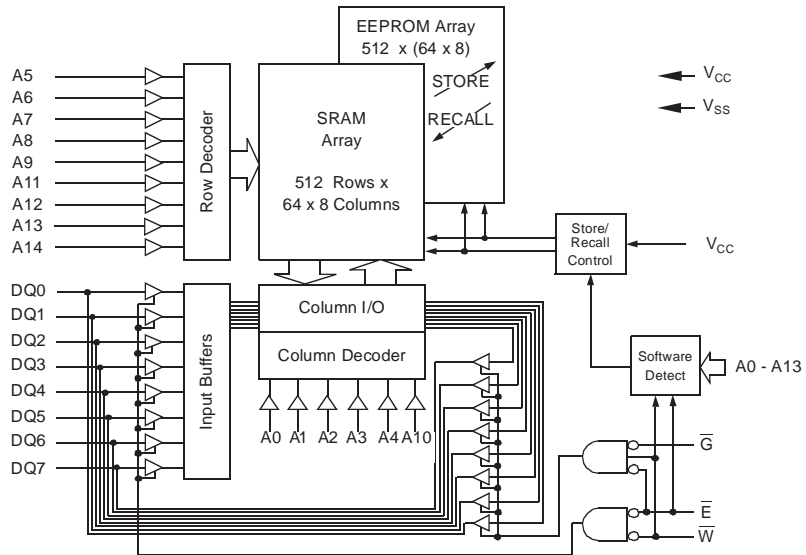

Truth Table for SRAM Operations

Operating Mode	\bar{E}	\bar{W}	\bar{G}	DQ0 - DQ7
Standby/not selected	H	*	*	High-Z
Internal Read	L	H	H	High-Z
Read	L	H	L	Data Outputs Low-Z
Write	L	L	*	Data Inputs High-Z

* H or L

Characteristics

All voltages are referenced to $V_{SS} = 0\text{ V}$ (ground).

All characteristics are valid in the power supply voltage range and in the operating temperature range specified.

Dynamic measurements are based on a rise and fall time of $\leq 5\text{ ns}$, measured between 10 % and 90 % of V_I , as well as input levels of $V_{IL} = 0\text{ V}$ and $V_{IH} = 3\text{ V}$. The timing reference level of all input and output signals is 1.5 V,

with the exception of the t_{dis} -times and t_{en} -times, in which cases transition is measured $\pm 200\text{ mV}$ from steady-state voltage.

Absolute Maximum Ratings ^a	Symbol	Min.	Max.	Unit
Power Supply Voltage	V_{CC}	-0.5	7	V
Input Voltage	V_I	-0.3	$V_{CC}+0.5$	V
Output Voltage	V_O	-0.3	$V_{CC}+0.5$	V
Power Dissipation	P_D		1	W
Operating Temperature	C-Type	0	70	°C
	K-Type	-40	85	°C
Storage Temperature	T_{stg}	-65	150	°C

a: Stresses greater than those listed under „Absolute Maximum Ratings“ may cause permanent damage to the device. This is a stress rating only, and functional operation of the device at condition above those indicated in the operational sections of this specification is not implied. Exposure to absolute maximum rating conditions for extended periods may affect reliability.

Recommended Operating Conditions	Symbol	Conditions	Min.	Max.	Unit
Power Supply Voltage	V_{CC}		4.5	5.5	V
Input Low Voltage	V_{IL}	-2 V at Pulse Width 10 ns permitted	-0.3	0.8	V
Input High Voltage	V_{IH}		2.2	$V_{CC}+0.3$	V

DC Characteristics	Symbol	Conditions	C-Type		K-Type		Unit
			Min.	Max.	Min.	Max.	
Operating Supply Current ^b	I_{CC1}	$V_{CC} = 5.5\text{ V}$ $V_{IL} = 0.8\text{ V}$ $V_{IH} = 2.2\text{ V}$ $t_c = 25\text{ ns}$ $t_c = 35\text{ ns}$ $t_c = 45\text{ ns}$		95 75 65		100 80 70	mA mA mA
Average Supply Current during STORE ^c	I_{CC2}	$V_{CC} = 5.5\text{ V}$ $\bar{E} \geq V_{CC}-0.2\text{ V}$ $\bar{W} \geq V_{CC}-0.2\text{ V}$ $V_{IL} \leq 0.2\text{ V}$ $V_{IH} \geq V_{CC}-0.2\text{ V}$		6		7	mA
Average Supply Current at $t_{CR} = 200\text{ ns}^b$ (Cycling CMOS Input Levels)	I_{CC3}	$V_{CC} = 5.5\text{ V}$ $\bar{W} \geq V_{CC}-0.2\text{ V}$ $V_{IL} \leq 0.2\text{ V}$ $V_{IH} \geq V_{CC}-0.2\text{ V}$		15		15	mA
Standby Supply Current ^d (Cycling TTL Input Levels)	$I_{CC(SB)1}$	$V_{CC} = 5.5\text{ V}$ $\bar{E} \geq V_{IH}$ $t_c = 25\text{ ns}$ $t_c = 35\text{ ns}$ $t_c = 45\text{ ns}$		40 36 33		42 38 35	mA mA mA
Standby Supply Current ^d (Stable CMOS Input Levels)	$I_{CC(SB)}$	$V_{CC} = 5.5\text{ V}$ $\bar{E} \geq V_{CC}-0.2\text{ V}$ $V_{IL} \leq 0.2\text{ V}$ $V_{IH} \geq V_{CC}-0.2\text{ V}$		1		1	mA

b: I_{CC1} and I_{CC3} are dependent on output loading and cycle rate. The specified values are obtained with outputs unloaded. The current I_{CC1} is measured for WRITE/READ - ratio of 1/2.

c: I_{CC2} is the average current required for the duration of the STORE cycle (t_{STORE}).

d: Bringing $\bar{E} \geq V_{IH}$ will not produce standby current levels until any nonvolatile cycle in progress has timed out. The current $I_{CC(SB)1}$ is measured for WRITE/READ - ratio of 1/2.

DC Characteristics	Symbol	Conditions	C-Type		K-Type		Unit
			Min.	Max.	Min.	Max.	
Output High Voltage Output Low Voltage	V_{OH} V_{OL}	$V_{CC} = 4.5\text{ V}$ $I_{OH} = -4\text{ mA}$ $I_{OL} = 8\text{ mA}$	2.4	0.4	2.4	0.4	V V
Output High Current Output Low Current	I_{OH} I_{OL}	$V_{CC} = 4.5\text{ V}$ $V_{OH} = 2.4\text{ V}$ $V_{OL} = 0.4\text{ V}$	8	-4	8	-4	mA mA
Input Leakage Current		$V_{CC} = 5.5\text{ V}$					
High	I_{IH}	$V_{IH} = 5.5\text{ V}$		1		1	μA
Low	I_{IL}	$V_{IL} = 0\text{ V}$	-1		-1		μA
Output Leakage Current		$V_{CC} = 5.5\text{ V}$					
High at Three-State- Output	I_{OHZ}	\bar{E} or $\bar{G} \geq V_{IH}$ $V_{OH} = 5.5\text{ V}$		1		1	μA
Low at Three-State- Output	I_{OLZ}	$V_{OL} = 0\text{ V}$	-1		-1		μA

SRAM MEMORY OPERATIONS

No.	Switching Characteristics Read Cycle	Symbol		25		35		45		Unit
		Alt.	IEC	Min.	Max.	Min.	Max.	Min.	Max.	
1	Read Cycle Time ^f	t_{AVAV}	t_{cR}	25		35		45		ns
2	Address Access Time to Data Valid ^g	t_{AVQV}	$t_{a(A)}$		25		35		45	ns
3	Chip Enable Access Time to Data Valid	t_{ELQV}	$t_{a(E)}$		25		35		45	ns
4	Output Enable Access Time to Data Valid	t_{GLQV}	$t_{a(G)}$		10		15		20	ns
5	\bar{E} HIGH to Output in High-Z ^h	t_{EHQZ}	$t_{dis(E)}$		10		13		15	ns
6	\bar{G} HIGH to Output in High-Z ^h	t_{GHQZ}	$t_{dis(G)}$		10		13		15	ns
7	\bar{E} LOW to Output in Low-Z	t_{ELQX}	$t_{en(E)}$	5		5		5		ns
8	\bar{G} LOW to Output in Low-Z	t_{GLQX}	$t_{en(G)}$	0		0		0		ns
9	Output Hold Time after Addr. Change ^g	t_{AXQX}	$t_{v(A)}$	3		3		3		ns
10	Chip Enable to Power Active ^e	t_{ELICCH}	t_{PU}	0		0		0		ns
11	Chip Disable to Power Standby ^{d, e}	t_{EHICCL}	t_{PD}		25		35		45	ns

e: Parameter guaranteed but not tested.

f: Device is continuously selected with \bar{E} and \bar{G} both Low.

g: Address valid prior to or coincident with \bar{E} transition LOW.

h: Measured $\pm 200\text{ mV}$ from steady state output voltage.

Read Cycle 1: Ai-controlled (during Read cycle: $\bar{E} = \bar{G} = V_{IL}, \bar{W} = V_{IH}$)^f

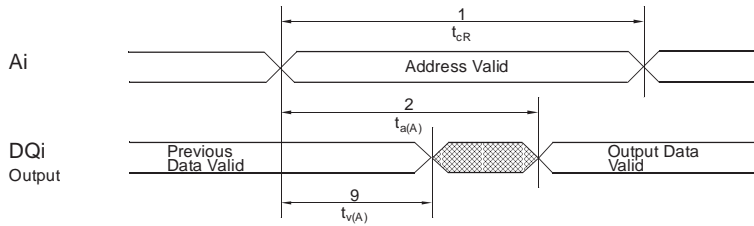

Read Cycle 2: \bar{G} -, \bar{E} -controlled (during Read cycle: $\bar{W} = V_{IH}$)^g

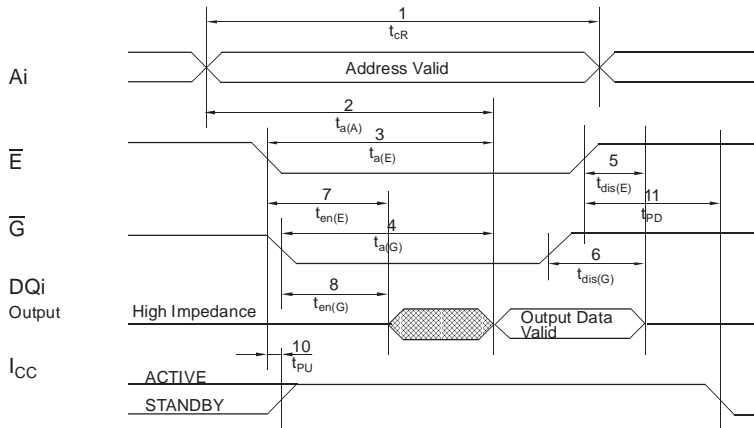

No.	Switching Characteristics Write Cycle	Symbol			25		35		45		Unit
		Alt. #1	Alt. #2	IEC	Min.	Max.	Min.	Max.	Min.	Max.	
12	Write Cycle Time	t_{AVAV}	t_{AVAV}	t_{cW}	25		35		45		ns
13	Write Pulse Width	t_{WLWH}		$t_{w(W)}$	20		25		30		ns
14	Write Pulse Width Setup Time		t_{WLEH}	$t_{su(W)}$	20		25		30		ns
15	Address Setup Time	t_{AVWL}	t_{AVEH}	$t_{su(A)}$	0		0		0		ns
16	Address Valid to End of Write	t_{AVWH}	t_{AVEH}	$t_{su(A-WH)}$	20		25		30		ns
17	Chip Enable Setup Time	t_{ELWH}		$t_{su(E)}$	20		25		30		ns
18	Chip Enable to End of Write		t_{ELEH}	$t_{w(E)}$	20		25		30		ns
19	Data Setup Time to End of Write	t_{DVWH}	t_{DVEH}	$t_{su(D)}$	10		12		15		ns
20	Data Hold Time after End of Write	t_{WHDX}	t_{EHDX}	$t_{h(D)}$	0		0		0		ns
21	Address Hold after End of Write	t_{WHAX}	t_{EHAX}	$t_{h(A)}$	0		0		0		ns
22	\bar{W} LOW to Output in High-Z ^{h, i}	t_{WLQZ}		$t_{dis(W)}$		10		13		15	ns
23	\bar{W} HIGH to Output in Low-Z	t_{WHQX}		$t_{en(W)}$	5		5		5		ns

U631H256

Write Cycle #1: \overline{W} -controlled^j

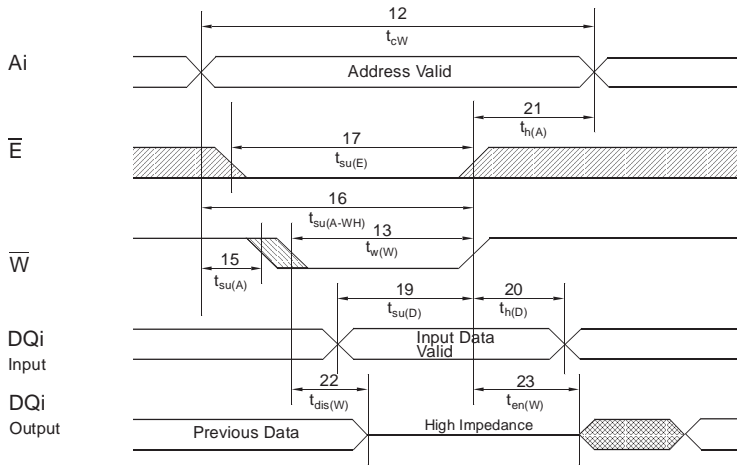

Write Cycle #2: \overline{E} -controlled^j

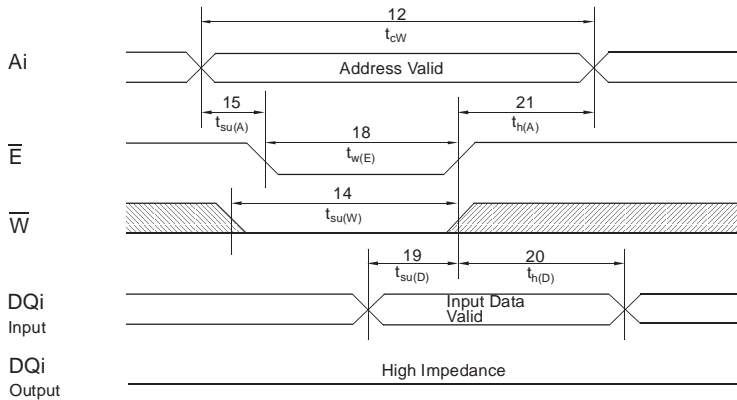

i: If \overline{W} is low and when \overline{E} goes low, the outputs remain in the high impedance state.

j: \overline{E} or \overline{W} must be $\geq V_{IH}$ during address transitions.

NONVOLATILE MEMORY OPERATIONS

No.	STORE CYCLE INHIBIT and AUTOMATIC POWER UP RECALL	Symbol		Min.	Max.	Unit
		Alt.	IEC			
24	Power Up RECALL Duration ^k	t_{RESTORE}			650	μs
	Low Voltage Trigger Level	V_{SWITCH}		4.0	4.5	V

k: t_{RESTORE} starts from the time V_{CC} rises above V_{SWITCH} .

STORE CYCLE INHIBIT and AUTOMATIC POWER UP RECALL

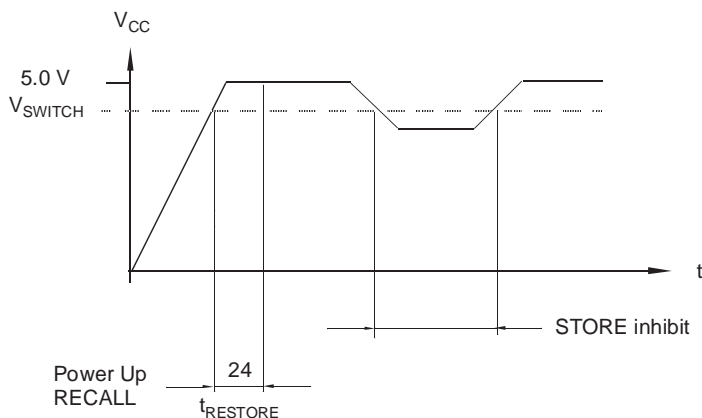

SOFTWARE MODE SELECTION

\bar{E}	\bar{W}	A13 - A0 (hex)	Mode	I/O	Power	Notes
L	H	0E38	Read SRAM	Output Data	Active	l, m
		31C7	Read SRAM	Output Data		l, m
		03E0	Read SRAM	Output Data		l, m
		3C1F	Read SRAM	Output Data		l, m
		303F	Read SRAM	Output Data		l, m
		0FC0	Nonvolatile STORE	Output High Z	I_{CC2}	l, m
L	H	0E38	Read SRAM	Output Data	Active	l, m
		31C7	Read SRAM	Output Data		l, m
		03E0	Read SRAM	Output Data		l, m
		3C1F	Read SRAM	Output Data		l, m
		303F	Read SRAM	Output Data		l, m
		0C63	Nonvolatile RECALL	Output High Z	l, m	

l: The six consecutive addresses must be in order listed. \bar{W} must be high during all six consecutive cycles. See STORE cycle and RECALL cycle tables and diagrams for further details.

The following six-address sequence is used for testing purposes and should not be used: 0E38, 31C7, 03E0, 3C1F, 303F, 339C.

m: While there are 15 addresses on the U631H256, only the lower 14 are used to control software modes.

No.	Software Controlled STORE/RECALL Cycle ^{1, n}	Symbol		25		35		45		Unit
		Alt.	IEC	Min.	Max.	Min.	Max.	Min.	Max.	
25	STORE/RECALL Initiation Time	t_{AVAV}	t_{cR}	25		35		45		ns
26	Chip Enable to Output Inactive ^o	t_{ELQZ}	$t_{dis(E)SR}$		600		600		600	ns
27	STORE Cycle Time ^p	t_{ELQXS}	$t_{d(E)S}$		10		10		10	ms
28	RECALL Cycle Time ^q	t_{ELQXR}	$t_{d(E)R}$		20		20		20	μ s
29	Address Setup to Chip Enable ^r	t_{AVELN}	$t_{su(A)SR}$	0		0		0		ns
30	Chip Enable Pulse Width ^{r, s}	t_{ELEHN}	$t_{w(E)SR}$	20		25		30		ns
31	Chip Disable to Address Change ^r	t_{EHAXN}	$t_{h(A)SR}$	0		0		0		ns

- n: The software sequence is clocked with \bar{E} controlled READS
- o: Once the software controlled STORE or RECALL cycle is initiated, it completes automatically, ignoring all inputs.
- p: Note that STORE cycles (but not RECALL) are aborted by $V_{CC} < V_{SWITCH}$ (STORE inhibit).
- q: An automatic RECALL also takes place at power up, starting when V_{CC} exceeds V_{SWITCH} and takes $t_{RESTORE}$. V_{CC} must not drop below V_{SWITCH} once it has been exceeded for the RECALL to function properly.
- r: Noise on the \bar{E} pin may trigger multiple READ cycles from the same address and abort the address sequence.
- s: If the Chip Enable Pulse Width is less than $t_{hi(E)}$ (see Read Cycle) but greater than or equal $t_{w(E)SR}$, then the data may not be valid at the end of the low pulse, however the STORE or RECALL will still be initiated.

SOFTWARE CONTROLLED STORE/RECALL CYCLE^{t, u} (\bar{E} = HIGH after STORE initiation)

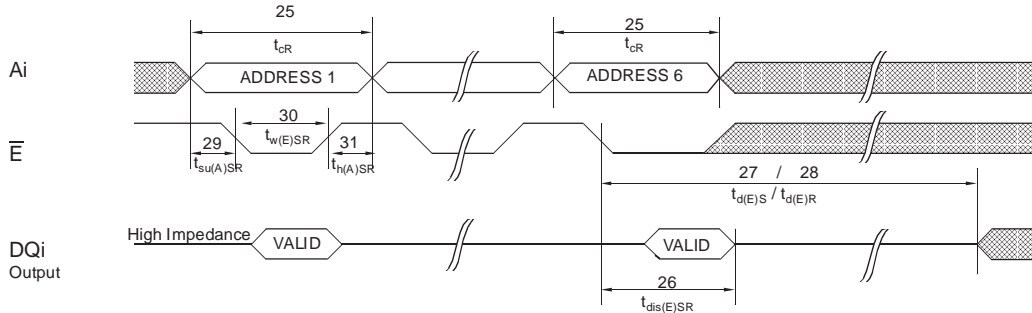

SOFTWARE CONTROLLED STORE/RECALL CYCLE^{r, s, t, u} (\bar{E} = LOW after STORE initiation)

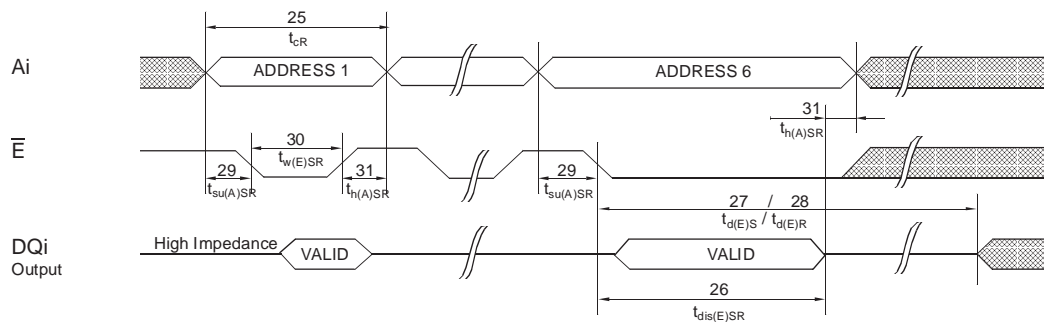

- t: \bar{W} must be HIGH when \bar{E} is LOW during the address sequence in order to initiate a nonvolatile cycle. \bar{G} may be either HIGH or LOW throughout. Addresses 1 through 6 are found in the mode selection table. Address 6 determines whether the U631H256 performs a STORE or RECALL.
- u: \bar{E} must be used to clock in the address sequence for the Software controlled STORE and RECALL cycles.

Test Configuration for Functional Check

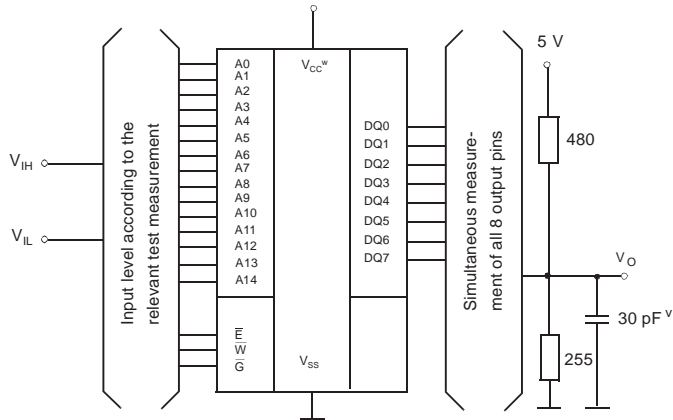

v: In measurement of t_{dis} -times and t_{en} -times the capacitance is 5 pF.

w: Between V_{CC} and V_{SS} must be connected a high frequency bypass capacitor 0.1 μ F to avoid disturbances.

Capacitance ^e	Conditions	Symbol	Min.	Max.	Unit
Input Capacitance	$V_{CC} = 5.0 \text{ V}$ $V_I = V_{SS}$	C_I		8	pF
Output Capacitance	$f = 1 \text{ MHz}$ $T_a = 25 \text{ }^\circ\text{C}$	C_O		7	pF

All pins not under test must be connected with ground by capacitors.

IC Code Numbers

Example

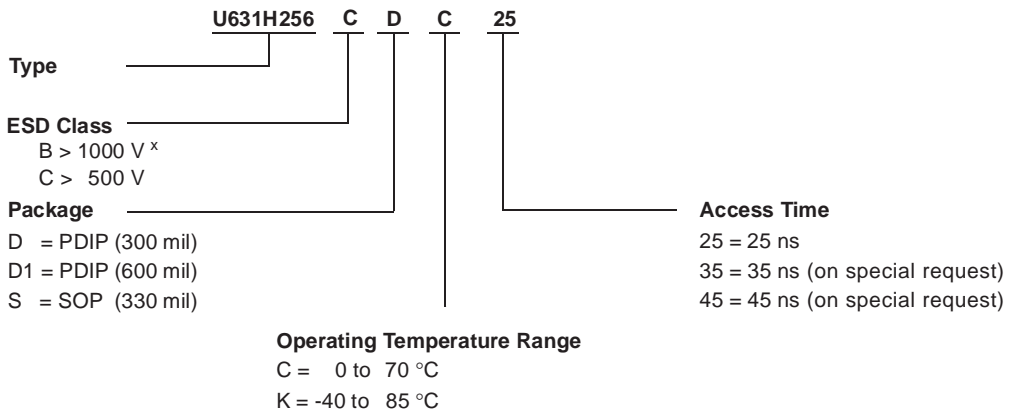

The date of manufacture is given by the last 4 digits of the mark, the first 2 digits indicating the year, and the last 2 digits the calendar week.

x: ESD protection > 1000 V and 2000 V under development

Device Operation

The U631H256 has two separate modes of operation: SRAM mode and nonvolatile mode. The memory operates in SRAM mode as a standard fast static RAM. Data is transferred in nonvolatile mode from SRAM to EEPROM shadow (the STORE operation) or from EEPROM to SRAM (the RECALL operation). In this mode SRAM functions are disabled.

SRAM READ

The U631H256 performs a READ cycle whenever \bar{E} and \bar{G} are LOW while \bar{W} is HIGH. The address specified on pins A0 - A14 determines which of the 32768 data bytes will be accessed. When the READ is initiated by an address transition, the outputs will be valid after a delay of t_{CR} . If the READ is initiated by \bar{E} or \bar{G} , the outputs will be valid at $t_{a(E)}$ or at $t_{a(G)}$, whichever is later. The data outputs will repeatedly respond to address changes within the t_{CR} access time without the need for transition on any control input pins, and will remain valid until another address change or until \bar{E} or \bar{G} is brought HIGH or \bar{W} is brought LOW.

SRAM WRITE

A WRITE cycle is performed whenever \bar{E} and \bar{W} are LOW. The address inputs must be stable prior to entering the WRITE cycle and must remain stable until either \bar{E} or \bar{W} goes HIGH at the end of the cycle. The data on pins DQ0 - 7 will be written into the memory if it is valid $t_{su(D)}$ before the end of a \bar{W} controlled WRITE or $t_{su(D)}$ before the end of a \bar{E} controlled WRITE. It is recommended that \bar{G} is kept HIGH during the entire WRITE cycle to avoid data bus contention on the common I/O lines. If \bar{G} is left LOW, internal circuitry will turn off the output buffers $t_{dis(W)}$ after \bar{W} goes LOW.

NOISE CONSIDERATION

The U631H256 is a high speed memory and therefore must have a high frequency bypass capacitor of approximately 0.1 μ F connected between V_{CC} and V_{SS} using leads and traces that are as short as possible. As with all high speed CMOS ICs, normal carefull routing of power, ground and signals will help prevent noise problems.

SOFTWARE NONVOLATILE STORE

The U631H256 software controlled STORE cycle is initiated by executing sequential READ cycles from six specific address locations. By relying on READ cycles only, the U631H256 implements nonvolatile operation while remaining compatible with standard 32K x 8 SRAMs. During the STORE cycle, an erase of the previous nonvolatile data is first performed, followed by a

program of the nonvolatile elements. Once a STORE cycle is initiated, further inputs and outputs are disabled until the cycle is completed.

Because a sequence of addresses is used for STORE initiation, it is important that no other READ or WRITE accesses intervene in the sequence or the sequence will be aborted and no STORE or RECALL will take place.

To initiate the STORE cycle the following READ sequence must be performed:

1. Read addresses 0E38 (hex) Valid READ
2. Read addresses 31C7 (hex) Valid READ
3. Read addresses 03E0 (hex) Valid READ
4. Read addresses 3C1F (hex) Valid READ
5. Read addresses 303F (hex) Valid READ
6. Read addresses 0FC0 (hex) Initiate STORE Cycle

Once the sixth address in the sequence has been entered, the STORE cycle will commence and the chip will be disabled. It is important that READ cycles and not WRITE cycles be used in the sequence, although it is not necessary that \bar{G} be LOW for the sequence to be valid. After the t_{STORE} cycle time has been fulfilled, the SRAM will again be activated for READ and WRITE operation.

SOFTWARE NONVOLATILE RECALL

A RECALL cycle of the EEPROM data into the SRAM is initiated with a sequence of READ operations in a manner similar to the STORE initiation. To initiate the RECALL cycle the following sequence of READ operations must be performed:

1. Read addresses 0E38 (hex) Valid READ
2. Read addresses 31C7 (hex) Valid READ
3. Read addresses 03E0 (hex) Valid READ
4. Read addresses 3C1F (hex) Valid READ
5. Read addresses 303F (hex) Valid READ
6. Read addresses 0C63 (hex) Initiate RECALL Cycle

Internally, RECALL is a two step procedure. First, the SRAM data is cleared and second, the nonvolatile information is transferred into the SRAM cells. The RECALL operation in no way alters the data in the EEPROM cells. The nonvolatile data can be recalled an unlimited number of times.

AUTOMATIC POWER UP RECALL

On power up, once V_{CC} exceeds the sense voltage of V_{SWITCH} , a RECALL cycle is automatically initiated. The voltage on the V_{CC} pin must not drop below V_{SWITCH} once it has risen above it in order for the RECALL to operate properly. Due to this automatic RECALL,

SRAM operation cannot commence until t_{RESTORE} after V_{CC} exceeds V_{SWITCH} .

If the U631H256 is in a WRITE state at the end of power up RECALL, the SRAM data will be corrupted. To help avoid this situation, a 10 k Ω resistor should be connected between \overline{W} and V_{CC} .

HARDWARE PROTECTION

The U631H256 offers hardware protection against inadvertent STORE operation through V_{CC} sense.

For $V_{\text{CC}} < V_{\text{SWITCH}}$ the software initiated STORE operation will be inhibited.

LOW AVERAGE ACTIVE POWER

The U631H256 has been designed to draw significantly less power when \overline{E} is LOW (chip enabled) but the access cycle time is longer than 55 ns.

When \overline{E} is HIGH the chip consumes only standby current.

The overall average current drawn by the part depends on the following items:

1. CMOS or TTL input levels
2. the time during which the chip is disabled (\overline{E} HIGH)
3. the cycle time for accesses (\overline{E} LOW)
4. the ratio of READs to WRITEs
5. the operating temperature
6. the V_{CC} level



Zentrum Mikroelektronik Dresden

Memory Products 1998

***SoftStore* 32K x 8 nvSRAM U631H256**

LIFE SUPPORT POLICY

ZMD products are not designed, intended, or authorized for use as components in systems intended for surgical implant into the body, or other applications intended to support or sustain life, or for any other application in which the failure of the ZMD product could create a situation where personal injury or death may occur. Components used in life-support devices or systems must be expressly authorized by ZMD for such purpose.

The information describes the type of component and shall not be considered as assured characteristics.

Terms of delivery and rights to change design reserved.

Zentrum Mikroelektronik Dresden GmbH

Grenzstraße 28 • D-01109 Dresden • P. O. B. 80 01 34 • D-01101 Dresden • Germany
Phone: +49 351 88 22-3 06 • Fax: +49 351 88 22-3 37 • Email: sales@zmd.de
Internet Web Site: <http://www.zmd.de>