

DATA SHEET

TX23/14/7.6
Alloy powder toroids

New data

2008 Sep 01

Alloy powder toroids

TX23/14/7.6

RING CORES (TOROIDS)

Effective core parameters

SYMBOL	PARAMETER	VALUE	UNIT	
$\Sigma(I/A)$	core factor (C1)	1.71	mm ⁻¹	
V_e	effective volume	1880	mm ³	
l_e	effective length	56.7	mm	
A_e	effective area	33.1	mm ²	
m	mass of core (for μ_i 125)	MPP	15.9	g
		Sendust	11.5	g
		High-Flux	15.0	g

Coating

The cores are coated with epoxy. The colour is black (Sendust), grey (MPP) or khaki (High-Flux). Maximum operating temperature is 200 °C.

Isolation voltage

AC isolation voltage : 1000 V.
Contacts are applied on the edge of the ring core, which is also the critical point for the winding operation.

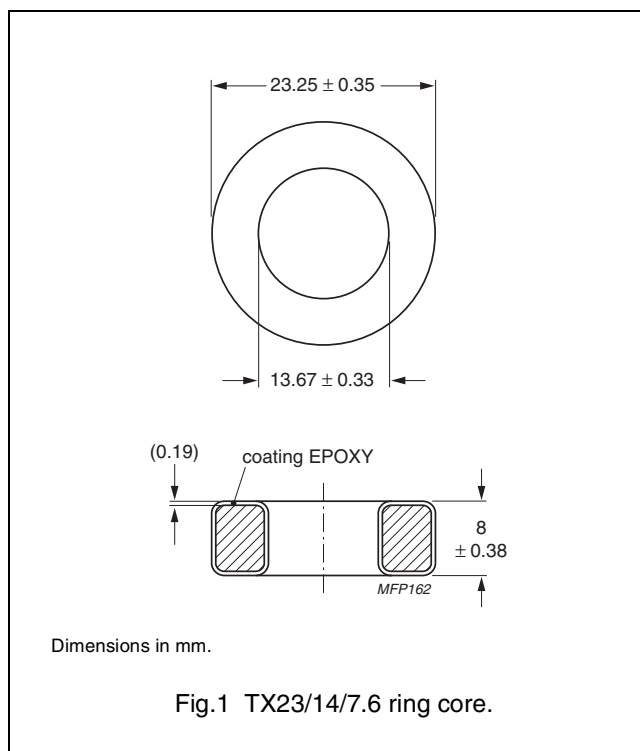

Ring core data - Note 1. Mechanical dimensions : OD ≤ 23.62, ID ≥ 13.39, H ≤ 8.38

GRADE	A_L (nH)	μ_i	B (mT) at	CORE LOSS (W) at	TYPE NUMBER
			H = 100 kA/m; f = 10 kHz; T = 25 °C	f = 100 kHz; $\hat{B} = 100$ mT; T = 25 °C	
MPP	9.9 ± 8 %	14	≥ 640	2.82	TX23/7.6-M2-A9.9
	19 ± 8 %	26	≥ 700	2.26	TX23/7.6-M2-A19
	43 ± 8 %	60	≥ 760	1.41	TX23/7.6-M2-A43
	90 ± 8 %	125	≥ 800	1.41	TX23/7.6-M2-A90
	106 ± 8 %	147	≥ 800	1.50	TX23/7.6-M2-A106
	115 ± 8 %	160	≥ 800	1.50	TX23/7.6-M2-A115
	124 ± 8 %	173	≥ 800	1.50	TX23/7.6-M2-A124
	144 ± 8 %	200	≥ 800	2.82	TX23/7.6-M2-A144
Sendust ⁽¹⁾	216 ± 8 %	300	≥ 800	2.82	TX23/7.6-M2-A216
	19 ± 8 %	26	≥ 1000	3.01	TX23/7.6-S7-A19-MC
	43 ± 8 %	60	≥ 1030	1.61	TX23/7.6-S7-A43-MC
	54 ± 8 %	75	≥ 1040	1.61	TX23/7.6-S7-A54-MC
	65 ± 8 %	90	≥ 1050	1.61	TX23/7.6-S7-A65-MC
High-Flux	90 ± 8 %	125	≥ 1060	1.61	TX23/7.6-S7-A90-MC
	9.9 ± 8 %	14	≥ 890	4.70	TX23/7.6-H2-A9.9
	19 ± 8 %	26	≥ 980	3.76	TX23/7.6-H2-A19
	43 ± 8 %	60	≥ 1280	3.38	TX23/7.6-H2-A43
	90 ± 8 %	125	≥ 1370	3.76	TX23/7.6-H2-A90
	106 ± 8 %	147	≥ 1385	4.14	TX23/7.6-H2-A106
	115 ± 8 %	160	≥ 1400	6.58	TX23/7.6-H2-A115



DATA SHEET STATUS DEFINITIONS

DATA SHEET STATUS	PRODUCT STATUS	DEFINITIONS
Preliminary specification	Development	This data sheet contains preliminary data. Ferroxcube reserves the right to make changes at any time without notice in order to improve design and supply the best possible product.
Product specification	Production	This data sheet contains final specifications. Ferroxcube reserves the right to make changes at any time without notice in order to improve design and supply the best possible product.

DISCLAIMER

Life support applications — These products are not designed for use in life support appliances, devices, or systems where malfunction of these products can reasonably be expected to result in personal injury. Ferroxcube customers using or selling these products for use in such applications do so at their own risk and agree to fully indemnify Ferroxcube for any damages resulting from such application.

PRODUCT STATUS DEFINITIONS

STATUS	INDICATION	DEFINITION
Prototype		These are products that have been made as development samples for the purposes of technical evaluation only. The data for these types is provisional and is subject to change.
Design-in		These products are recommended for new designs.
Preferred		These products are recommended for use in current designs and are available via our sales channels.
Support		These products are not recommended for new designs and may not be available through all of our sales channels. Customers are advised to check for availability.