

## General Description

The TMR400X magnetic gear tooth sensors utilize a unique push-pull Wheatstone bridge design, including one or two Wheatstone full bridges, with four or eight unshielded high sensitivity TMR sensing elements. The Wheatstone bridge creates a differential voltage output with respect to the magnetic field gradient along the sensor's sensitive direction. In the dual-bridge configuration, the two orthogonal Wheatstone full bridges provide sine and cosine voltage signals that can be used to measure both the gear tooth position and the direction of motion. The TMR400X magnetic gear tooth sensors offer superior performance with high sensitivity to the magnetic field gradient. They can detect very small changes in magnetic field, along with good temperature stability of the output signal.

The TMR400X magnetic gear tooth sensors are available in 6 different standard spacings of 0.25mm, 0.5mm, 0.75mm, 1.0mm, 2.0mm, and 3.0mm. Two types of small form factor LGA packages are available. The package dimensions are 3mm x 3mm x 0.9mm, and 3mm x 6mm x 0.9mm.

## Features and Benefits

- Tunneling Magnetoresistance (TMR) Technology
- High Saturation Point Allowing Operation under Large DC Magnetic Field
- Wide Air-Gap Tolerance
- High Sensitivity to Magnetic Field Gradient
- Capable of Small-Pitch Gear Tooth Detection
- DC(Zero-Speed) Operation
- Sine/Cosine Signal Outputs with Precise Phase Shift
- Excellent Thermal Stability
- Good Immunity to Environmental Magnetic Field
- Compact Ultra-Thin Package

## Applications

- Gear Tooth Motion, Speed, and Direction Sensing
- Linear and Rotary Speed Sensing
- Linear and Rotary position Sensing
- Linear Magnetic Scales
- Magnetic Encoders



TMR400X

## Wheatstone Bridge Connection

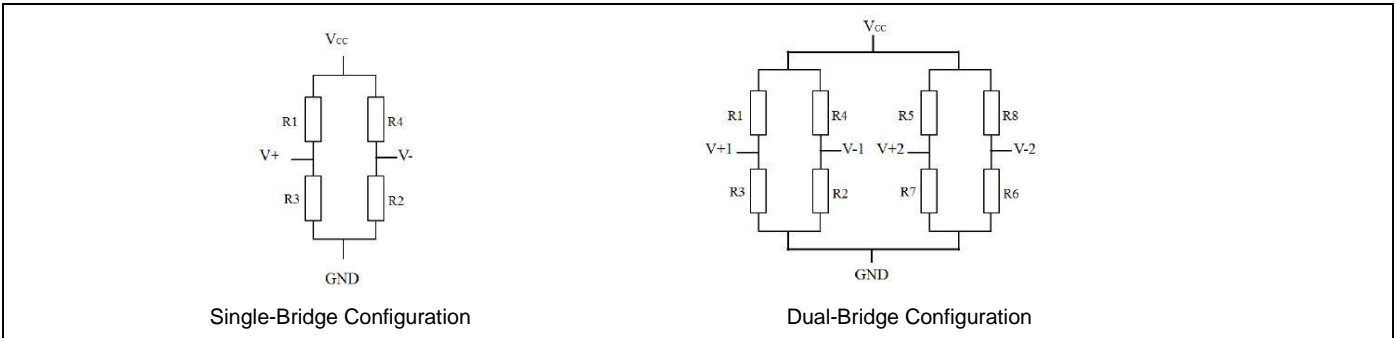

## Pin Configuration

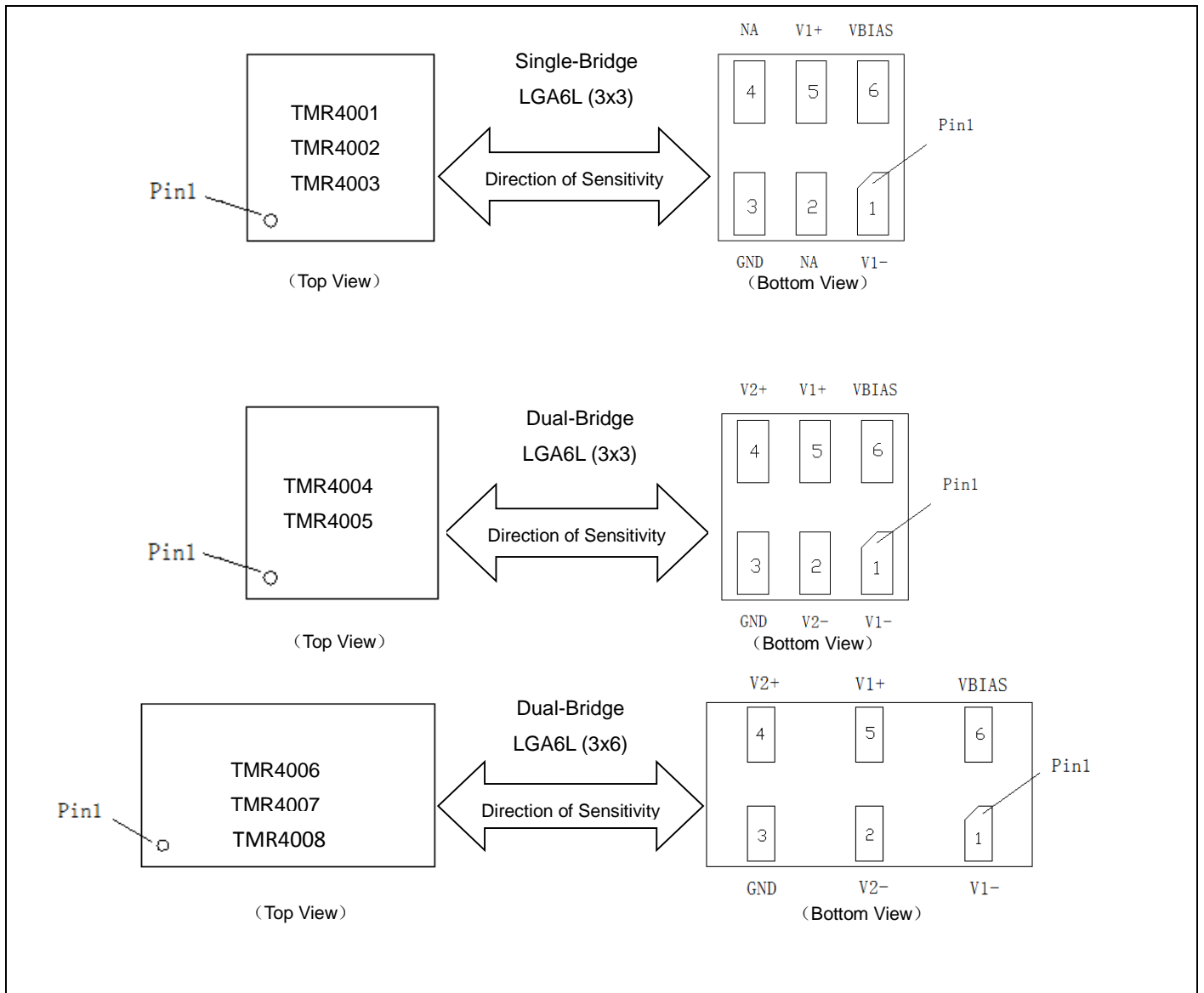

\*TMR4009 is LGA6L(3x8) package

Pin No.	Pin Name	Pin Function
1	V1-	Differential Output (-) of Bridge 1
2	V2- *	Differential Output (-) of Bridge 2 *
3	GND	Ground
4	V2+ *	Differential Output (+) of Bridge 2 *
5	V1+	Differential Output (-) of Bridge 1
6	V <sub>CC</sub>	Supply Voltage

### Absolute Maximum Ratings

Parameter	Symbol	Limit	Unit
Supply Voltage	V <sub>CC</sub>	7	V
Reverse Supply Voltage	V <sub>RCC</sub>	7	V
Magnetic Field	H	1500	Oe <sup>(1)</sup>
ESD Voltage	V <sub>ESD</sub>	4000	V
Operating Temperature	T <sub>A</sub>	-40 ~ 125	°C
Storage Temperature	T <sub>stg</sub>	-50 ~150	°C

### Specification (V<sub>CC</sub>=1.0V, T<sub>A</sub>=25°C, Differential Output)

Parameter	Symbol	Conditions	Min	Typ	Max	Unit
Supply Voltage	V <sub>CC</sub>	Operating		1	7	V
Supply Current	I <sub>CC</sub>	Output Open		67 <sup>(2)</sup>		μA
Bridge Resistance	R			15 <sup>(3)</sup>		kOhm
Single Resistor Sensitivity	SEN		-	0.46		%ΔR/Oe
Saturation Field	H <sub>sat</sub>			± 70 <sup>(4)</sup>		Oe
Linear Range 1	LIN1	Linearity ≥ 98%		± 20		Oe
Linear Range 2	LIN2	Linearity ≥ 95%		± 40		Oe
Offset Voltage	V <sub>offset</sub>		-20		20	mV/V
Hysteresis	Hys	Fit @ ±20 Oe		1		%FS
Maximum Differential Voltage Output	V <sub>outMax</sub>			650		mV/V
Temperature Coefficient of Resistance	TCR	H = 0 Oe		-985		PPM/°C
Temperature Coefficient of Sensitivity	TCS			-1800		PPM/°C

Note:

(1) 1 Oe (Oersted) = 1 Gauss in air = 0.1 millitesla = 79.8 A/m.

(2) Supply current is determined by the resistance of the sensor.

(3) Custom sensor resistance may be available upon request.

(4) The sensors may saturate if the magnetic field exceeds this range. Saturation field can be custom designed to meet special requirements.

### TMR Element Layout

Part Number	Single/ Dual Bridge	TMR Element Spacing (mm) (TMR elements are placed symmetrically with respect to the center of the package, which is marked by the “+” symbol.)	Approx. Gear Tooth Pitch Range	Package Format
TMR4001	Single		optimal pitch at 0.5mm	LGA6L (3x3)
TMR4002	Single		optimal pitch at 1.0mm	LGA6L (3x3)
TMR4003	Single		optimal pitch at 1.5mm	LGA6L (3x3)
TMR4004	Dual		optimal pitch at 1.0mm	LGA6L (3x3)
TMR4005	Dual		optimal pitch at 2.0mm	LGA6L (3x3)
TMR4006	Dual		optimal pitch at 4.0mm	LGA6L (3x6)
TMR4007	Dual		optimal pitch at 6.0mm	LGA6L (3x6)
TMR4008	Dual		optimal pitch at 8.0mm	LGA6L (3x6)
TMR4009	Dual		optimal pitch at 10.0mm	LGA6L (3x8)

Package Information

LGA6L (3x3) package drawing:

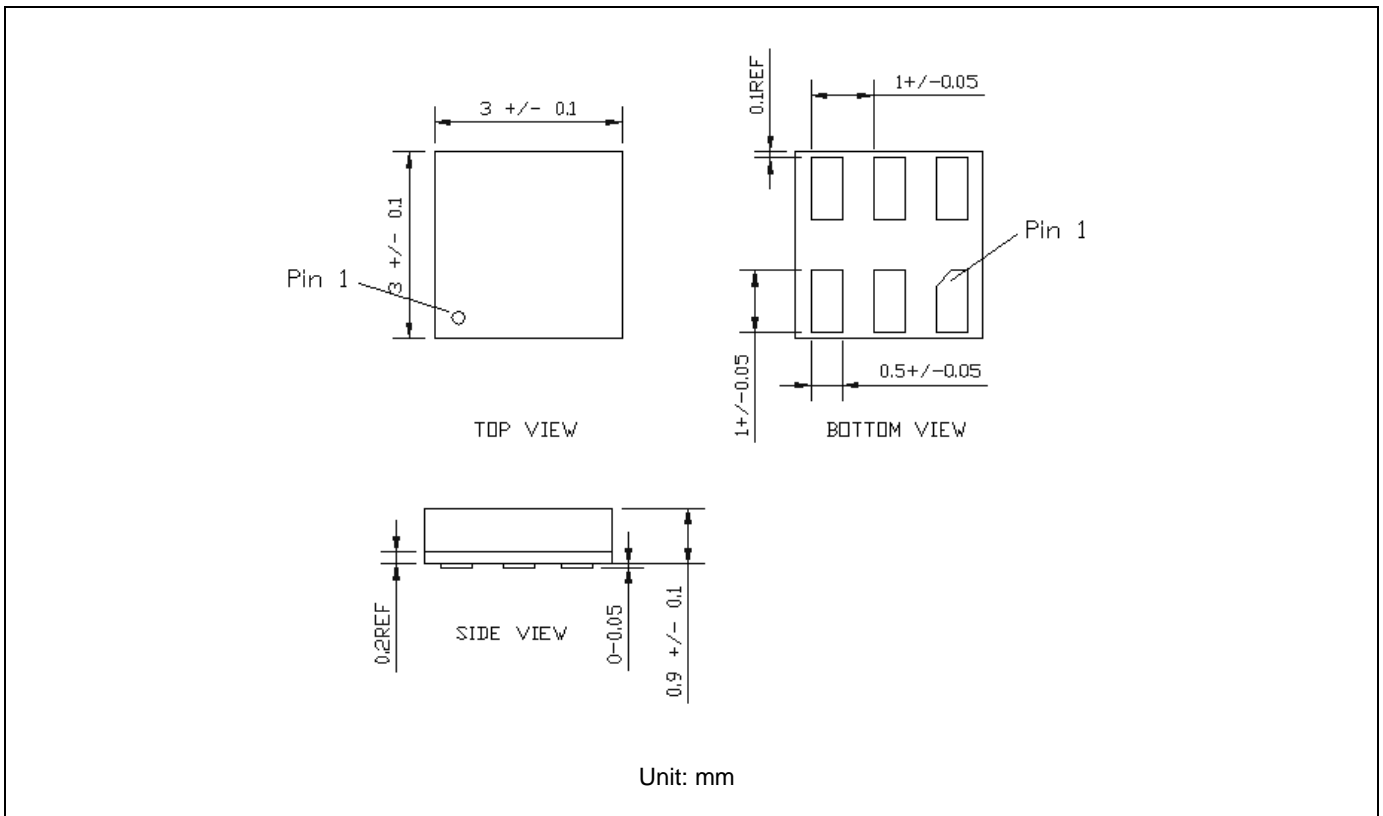

LGA6L (3x6) package drawing:

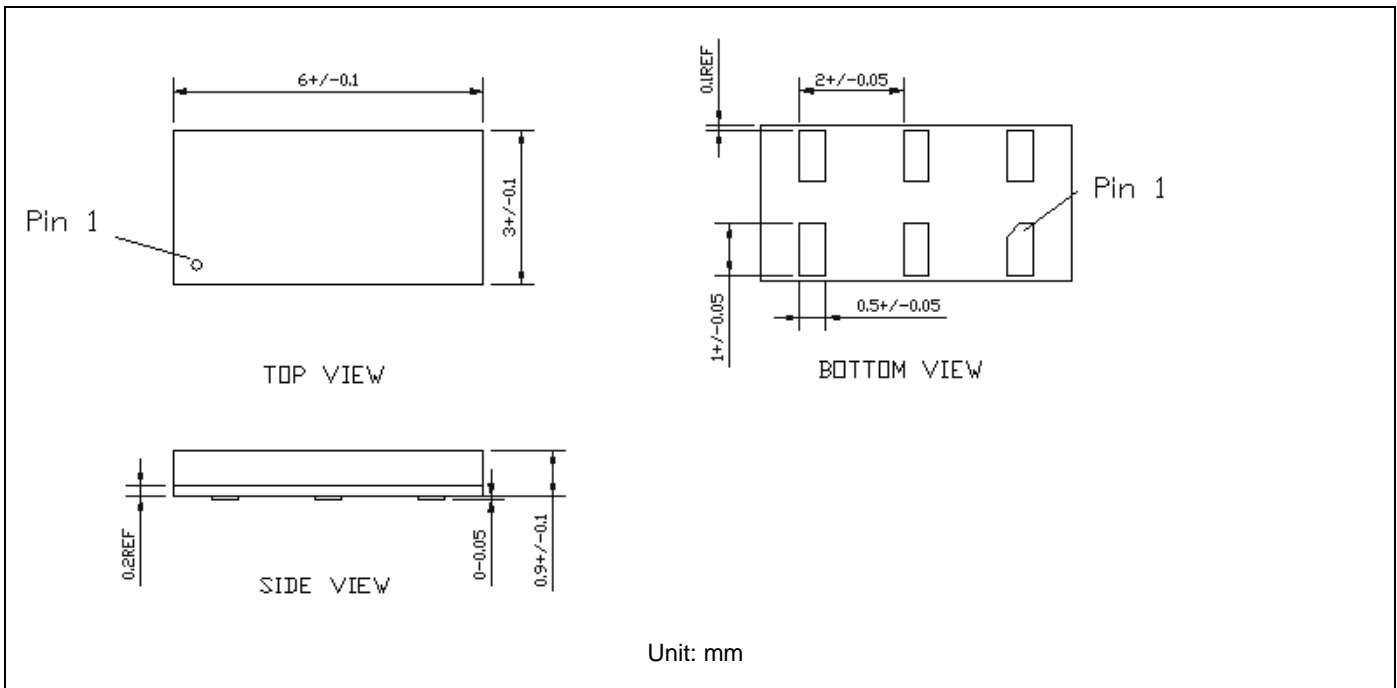

### TMR Sensor Position

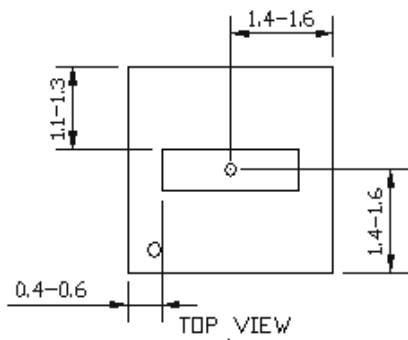

TOP VIEW

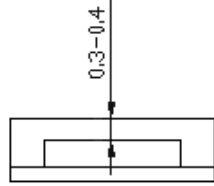

SIDE VIEW

LGA6L (3x3)

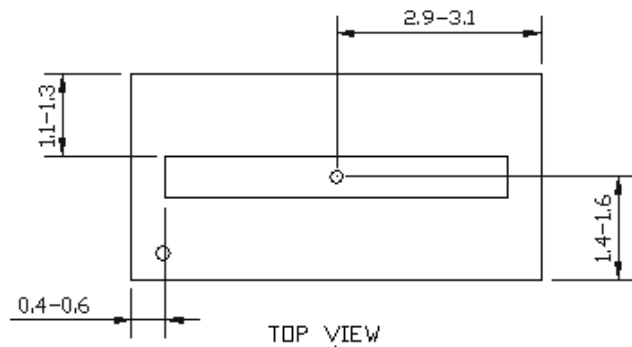

TOP VIEW

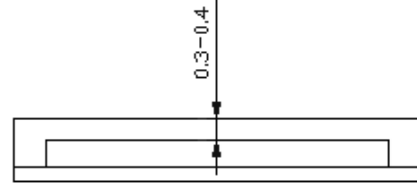

SIDE VIEW

LGA6L (3x6)



Top view and side view(unit: mm)



**MultiDimension Technology Co., Ltd.**

Address: No.7 Guangdong Road, Zhangjiagang Free Trade Zone, Jiangsu, 215634, China

Web: [www.dowaytech.com/en](http://www.dowaytech.com/en)

Email: [info@dowaytech.com](mailto:info@dowaytech.com)

The information provided herein by MultiDimension Technology Co., Ltd. (hereinafter MultiDimension) is believed to be accurate and reliable. Publication neither conveys nor implies any license under patent or other industrial or intellectual property rights. MultiDimension reserves the right to make changes to product specifications for the purpose of improving product quality, reliability, and functionality. MultiDimension does not assume any liability arising out of the application and use of its products. MultiDimension's customers using or selling this product for use in appliances, devices, or systems where malfunction can reasonably be expected to result in personal injury do so at their own risk and agree to fully indemnify MultiDimension for any damages resulting from such applications.