

ADVANCED INFORMATION

CMOS LDO REGULATOR WITH HIGH ACTIVE CONTROL

FEATURES

- Low Dropout Voltage
- Very Low Quiescent Current (50 μ A maximum)
- Internal Bandgap Reference
- Regulates down to 1.8 V
- Short Circuit Protection
- Very Low Standby Current (1 μ A maximum)
- Miniature Package (SOT-23-5)

APPLICATIONS

- Battery Powered Systems
- Cellular Telephones
- Pagers
- Toys
- Radio Control Systems
- Low Voltage Systems
- Personal Communications Systems
- Portable Instrumentation
- Portable Consumer Equipment

DESCRIPTION

The device is a low dropout linear regulation housed in a small SOT-23-5 package, rated at 500 mW.

An internal P Channel pass transistor is used in order to achieve low dropout voltage. The device has extremely low quiescent current (max 50 μ A). The device offers high precision output voltage of 2% at over temperature. The low quiescent current and dropout voltage make this part ideal for battery powered applications. In the standby mode when the device is disabled, the linear regulator only draws 1 μ A (max).

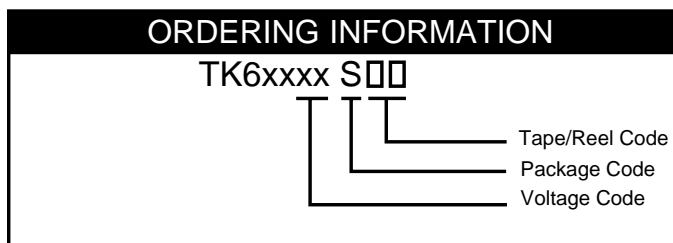
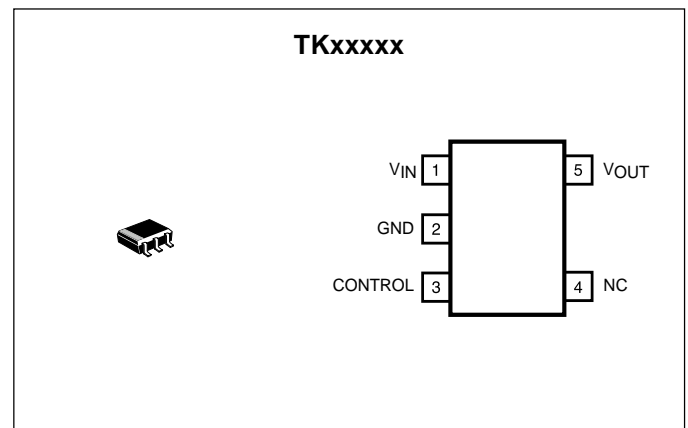

VOLTAGE CODE		
18 = 1.8 V	33 = 3.3 V	55 = 5.5 V
20 = 2.0 V	35 = 3.5 V	60 = 6.0 V
25 = 2.5 V	40 = 4.0 V	
28 = 2.8 V	45 = 4.5 V	
30 = 3.0 V	50 = 5.0 V	

TAPE/REEL CODE	
TL:	Tape Left
PACKAGE CODE	
S:	SOT-23-5

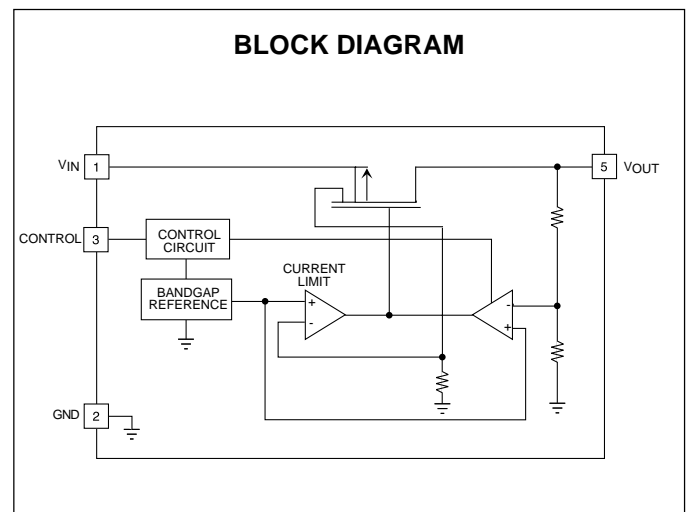

ADVANCED INFORMATION

ABSOLUTE MAXIMUM RATINGS

All pins except GND 9 V
 Power Dissipation (Note 1) 500 mW
 Storage Temperature Range -55 to +150 °C

Operating Temp. Range -30 to +80 °C
 Junction Temperature 150 °C

ELECTRICAL CHARACTERISTICS

Test conditions: $V_{IN} = V_{OUT(TYP)} + 1\text{ V}$, $T_A = 25\text{ °C}$, unless otherwise specified.

SYMBOL	PARAMETER	TEST CONDITIONS	MIN	TYP	MAX	UNITS
V_{IN}	Input Supply				8	V
I_Q	Quiescent Current	No Load		30	50	μA
I_{STBY}	Standby Current	$V_{IN} = 8\text{ V}$, Output Off			1	μA
I_{OUT}	Output Current		50			mA
V_{OUT}	Output Voltage	Note 2, $T_A = -30\text{ to }+80\text{ °C}$, $I_{OUT} = 1\text{ mA}$	-2%	V_{OUT}	2%	V
Load Reg	Load Regulation	$I_{OUT} = 1\text{ mA to }50\text{ mA}$			200	mV
Line Reg	Line Regulation	$V_{OUT(TYP)} + 0.5\text{ V} \leq V_{IN} \leq 8\text{ V}$, $I_{OUT} = 1\text{ mA}$		TBD		mV
V_{DROP}	Dropout Voltage	$I_{OUT} = 50\text{ mA}$		55	200	mV
CONTROL TERMINAL SPECIFICATIONS						
I_{CONT}	Control Current	$V_{CONT} = 1.5\text{ V}$, Output ON		TBD		μA
V_{CONT} (ON)	Control Voltage ON	Output ON	1.5			V
V_{CONT} (OFF)	Control Voltage OFF	Output OFF			0.25	V

Note 1: Power dissipation is 500 mW when mounted as recommended (150 mW in Free Air). Derate at 1.8 mW/°C for operation above 25 °C.

Note 2: $V_{OUT} = 1.8\text{ V to }6\text{ V}$, 0.1 V step.

ADVANCED INFORMATION

DEFINITION AND EXPLANATION OF TECHNICAL TERMS

OUTPUT VOLTAGE (V_{OUT})

The output voltage is specified with $V_{IN} = (V_{OUT(TYP)} + 1 \text{ V})$ and $I_{OUT} = 1 \text{ mA}$.

DROPOUT VOLTAGE (V_{DROP})

The dropout voltage is the difference between the input voltage and the output voltage at which point the regulator starts to fall out of regulation. Below this value, the output voltage will fall as the input voltage is reduced. It is dependent upon the load current and the junction temperature.

OUTPUT CURRENT (I_{OUT})

Normal operating output current. This is limited by package power dissipation.

LINE REGULATION (Line Reg)

Line regulation is the ability of the regulator to maintain a constant output voltage as the input voltage changes. The line regulation is specified as the input voltage is changed from $V_{IN} = V_{OUT} + 0.5 \text{ V}$ to $V_{IN} = 8 \text{ V}$.

LOAD REGULATION (Load Reg)

Load regulation is the ability of the regulator to maintain a constant output voltage as the load current changes. It is a pulsed measurement to minimize temperature effects with the input voltage set to $V_{IN} = V_{OUT} + 1 \text{ V}$. The load regulation is specified under output current step conditions of 1 mA to 50 mA.

QUIESCENT CURRENT (I_Q)

The quiescent current is the current which flows through the ground terminal under no load conditions ($I_{OUT} = 0 \text{ mA}$).

STANDBY CURRENT (I_{STBY})

Standby current is the current which flows into the regulator when the output is turned off by the control function ($V_{CONT} = 0 \text{ V}$). It is measured with $V_{IN} = 8 \text{ V}$.

SENSOR CIRCUITS

Overcurrent Sensor

The overcurrent sensor protects the device if the output is shorted to ground.

PACKAGE POWER DISSIPATION (P_D)

This is the power dissipation level at which the thermal sensor is activated. The IC contains an internal thermal sensor which monitors the junction temperature. When the junction temperature exceeds the monitor threshold of 150 °C, the IC is shut down. The junction temperature rises as the difference between the input power ($V_{IN} \times I_{IN}$) and the output power ($V_{OUT} \times I_{OUT}$) increases. The rate of temperature rise is greatly affected by the mounting pad configuration on the PCB, the board material, and the ambient temperature. When the IC mounting has good thermal conductivity, the junction temperature will be low even if the power dissipation is great. When mounted on the recommended mounting pad, the power dissipation of the SOT-23-5 is increased to 500 mW. For operation at ambient temperatures over 25 °C, the power dissipation of the SOT-23-5 device should be derated at 4.0 mW/°C. To determine the power dissipation for shutdown when mounted, attach the device on the actual PCB and deliberately increase the output current (or raise the input voltage) until the thermal protection circuit is activated. Calculate the power dissipation of the device by subtracting the output power from the input power. These measurements should allow for the ambient temperature of the PCB. The value obtained from $P_D / (150 \text{ °C} - T_A)$ is the derating factor. The PCB mounting pad should provide maximum thermal conductivity in order to maintain low device temperatures. As a general rule, the lower the temperature, the better the reliability of the device. The thermal resistance when mounted is expressed as follows:

$$T_j = \theta_{jA} \times P_D + T_A$$

For Toko ICs, the internal limit for junction temperature is 150 °C. If the ambient temperature (T_A) is 25 °C, then:

$$150 \text{ °C} = \theta_{jA} \times P_D + 25 \text{ °C}$$
$$\theta_{jA} = 125 \text{ °C} / P_D$$

ADVANCED INFORMATION

DEFINITION AND EXPLANATION OF TECHNICAL TERMS (CONT.)

P_D is the value when the thermal protection circuit is activated. A simple way to determine P_D is to calculate $V_{IN} \times I_{IN}$ when the output side is shorted. Input current gradually falls as temperature rises. You should use the value when thermal equilibrium is reached.

The range of usable currents can also be found from the graph below.

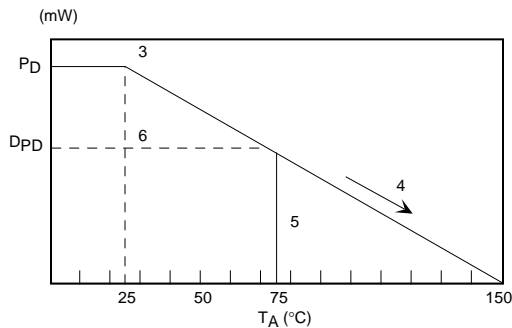

Procedure:

- 1) Find P_D
- 2) P_{D1} is taken to be $P_D \times (-0.8 - 0.9)$
- 3) Plot P_{D1} against 25 °C
- 4) Connect P_{D1} to the point corresponding to the 150 °C with a straight line.
- 5) In design, take a vertical line from the maximum operating temperature (e.g., 75 °C) to the derating curve.
- 6) Read off the value of P_D against the point at which the vertical line intersects the derating curve. This is taken as the maximum power dissipation, D_{PD} .

The maximum operating current is:

$$I_{OUT} = (D_{PD} / (V_{IN(MAX)} - V_{OUT}))$$

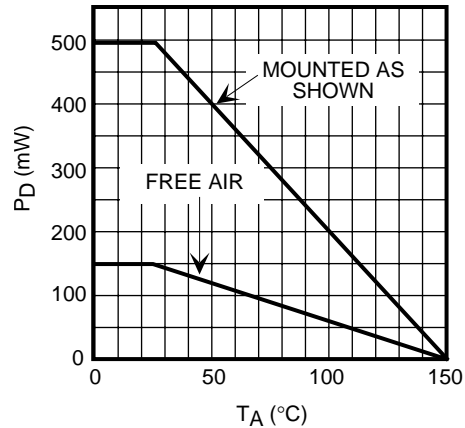

SOT-23-5 POWER DISSIPATION CURVE

ADVANCED INFORMATION

APPLICATION INFORMATION

BOARD LAYOUT

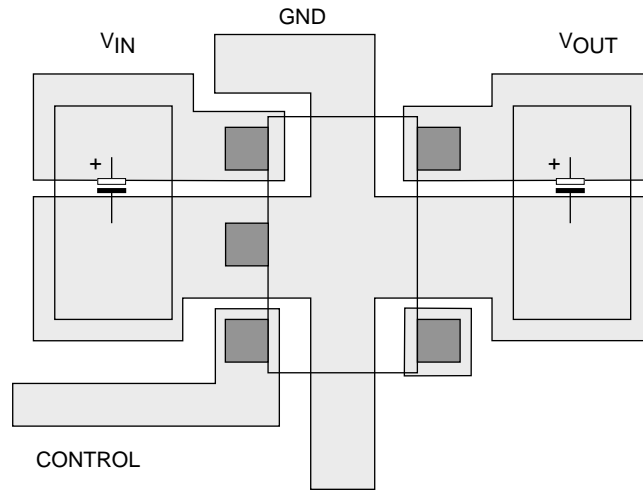

SOT-23-5 BOARD LAYOUT

ADVANCED INFORMATION

PACKAGE OUTLINE

SOT-23-5

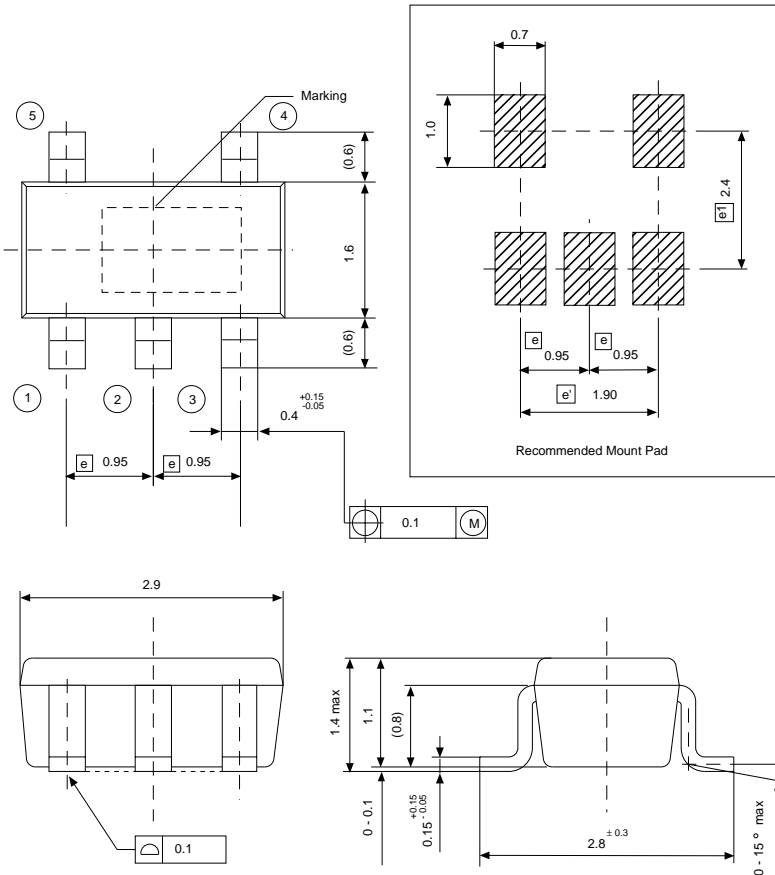

Dimensions are shown in millimeters
Tolerance: x.x = ± 0.2 mm (unless otherwise specified)

Marking Information

Part Number Marking



Toko America, Inc. Headquarters
1250 Feehanville Drive, Mount Prospect, Illinois 60056
Tel: (847) 297-0070 Fax: (847) 699-7864

TOKO AMERICA REGIONAL OFFICES

Midwest Regional Office
Toko America, Inc.
1250 Feehanville Drive
Mount Prospect, IL 60056
Tel: (847) 297-0070
Fax: (847) 699-7864

Western Regional Office
Toko America, Inc.
2480 North First Street, Suite 260
San Jose, CA 95131
Tel: (408) 432-8281
Fax: (408) 943-9790

Eastern Regional Office
Toko America, Inc.
107 Mill Plain Road
Danbury, CT 06811
Tel: (203) 748-6871
Fax: (203) 797-1223

Semiconductor Technical Support
Toko Design Center
4755 Forge Road
Colorado Springs, CO 80907
Tel: (719) 528-2200
Fax: (719) 528-2375

Visit our Internet site at <http://www.tokoam.com>

The information furnished by TOKO, Inc. is believed to be accurate and reliable. However, TOKO reserves the right to make changes or improvements in the design, specification or manufacture of its products without further notice. TOKO does not assume any liability arising from the application or use of any product or circuit described herein, nor for any infringements of patents or other rights of third parties which may result from the use of its products. No license is granted by implication or otherwise under any patent or patent rights of TOKO, Inc.