

K-Bus Interface

Features and Benefits

- Open-emitter output with slew rate control
- Quiescent current < 50mA
- Bus voltage range -16 V .. +30 V
- ISO 9141 and OBDII compliant
- Wide temperature range -40 .. 125 °C
- SOP-14 or SOP-8 package
- Baudrate 9600
- Automotive applications

Pin Diagram

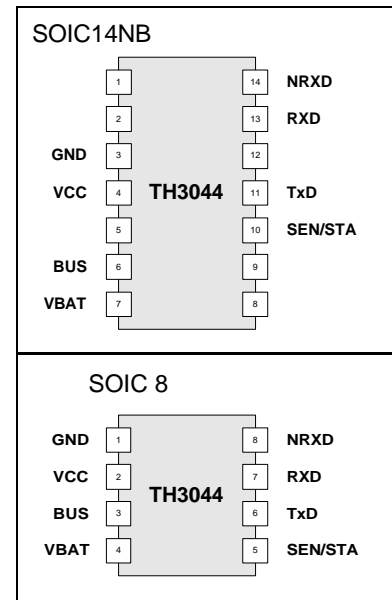

Ordering Information

Part No.	Temperature Range	Package
TH3044.3A	-40°C...125°C	SOIC14, 150mil
TH3044 JDC	-40°C...125°C	SOIC8

General Description

The TH3044 is a bidirectional bus interface device for data transfer from 5V to 12V supply. For proper functionality control units are implemented.

This interface device was especially designed for automotive applications.

Electrical Characteristics

All voltages are referenced to ground (GND). Positive currents flow into the IC. The absolute maximum ratings (in accordance with IEC 134) given in the table below are limiting values that do not lead to a permanent damage of the device but exceeding any of these limits may do

so. Long term exposure to limiting values may affect the reliability of the device. Reliable operation of the TH3044 is only specified within the limits shown in "Operating conditions"

Operating Conditions

Parameter	Symbol	Min	Typ	Max	Unit
Battery Voltage	V_{BAT}	6		16	V
Supply Voltage	V_{CC}	4.5		5.5	V
Operating Temperature	T_A	-40		125	°C

Absolute maximum ratings

Parameter	Symbol	Condition	Min	Max	Unit
Battery Voltage	V_{BAT}		-0.3	30	V
		$T \leq 500 \text{ ms}$		40	
Battery Current	I_{BAT}			20	mA
Supply Voltage	V_{CC}			7	V
Supply Current	I_{CC}			10	mA
Input Voltage SEN/STA, TxD	V_{IN}		-0.3	$V_{CC}+0.3$	V
Input Current SEN/STA, TxD	I_{IN}		-10	10	mA
Input Voltage BUS	V_{INBUS}		-16	30	V
		$T \leq 500 \text{ ms}$		40	
Output Current RxD, NRxD	I_{OUT}		-10	10	mA
Operating Temperature	T_A		-40	125	°C

Static Characteristics

$V_{DD} = 4.5$ to $5.5V$, $V_{Bat} = 6$ to $16V$, $T_{amb} = -40^{\circ}C$ to $+125^{\circ}C$, unless otherwise specified

Parameter	Symbol	Condition	Min	Typ	Max	Unit
Supply						
Power-on-reset Threshold VCC	V_{CCPOR}		3.0		4.0	V
Power-on-reset Threshold VBAT	V_{BATPOR}		3.0		4.5	V
Quiescent Current, ICC + IBAT	I_{CCBAT}	VCC = 5V, VBAT = 12V, BUS, TxD, SEN/STA, RxD and NRxD open			50	μA
TxD, SEN/STA, RxD, NRxD						
Pull-up Current TxD	I_{pu}		-330	-250	-170	μA
Pull-down Current SEN/STA	I_{pdSEN}		170	250	330	μA
Pull-up Current SEN/STA	I_{puSEN}		-330	-250	-170	μA
Input Voltage Low TxD, SEN/STA	V_{IL}				0.25	V_{CC}
Input Voltage High TxD, SEN/STA	V_{IH}		0.75			V_{CC}
Output Voltage Low RxD, NRxD	V_{OL}	$I_{OUT} = 1\text{ mA}$			1	V
Output Voltage High RxD, NRxD	V_{OH}	$I_{OUT} = 1\text{ mA}$	$V_{CC} - 1.0$			V
BUS						
Input Voltage Low BUS	V_{IL}				0.45	V_{BAT}
Input Voltage High BUS	V_{IH}		0.55			V_{BAT}
Hysteresis Input Voltage	V_{HYS}			50		mV
Input Resistance BUS	R_{IN}	$V_{BAT} = 0.40V$	400	600	1500	$k\Omega$
		$V_{BAT} = 0.40V, T_A = 85^{\circ}C$			1300	$k\Omega$
		$V_{BUS} = 12V$	60			$k\Omega$
Output Voltage BUS	V_{BUS}	VBAT = 12V, SEN/STA = Low, $I_{BUS} = 40mA$			1.2	V
		$I_{BUS} = 25mA$			1.0	V
Output Sinking Current BUS (current limiting)	I_{LIM}	$V_{BUS} > 3.5V$	40		110	mA
Output Sinking Current BUS (before fold back)	I_{BUS}				180	mA

Dynamic Characteristics

Parameter	Symbol	Condition	Min	Typ	Max	Unit
Propagation Delay TxD -> RxD, NRxD	t_{pd}				20	μs
Threshold Voltage Fold-Back	V_{FB}				3.0	V
Slew Rate BUS	dV/dT_{fall}		-2.2	-1.6	-1.0	$V/\mu s$
	dV/dT_{rise}		1.0	1.6	2.2	$V/\mu s$
Symmetry of Slew Rate BUS	dV/dT_{sym}				0.3	$V/\mu s$
Debouncing Time BUS	t_{debH} t_{debL}	High or Low Pulse	1.5	2.8	4.0	μs
Symmetry of Debouncing Time BUS	t_{debsym}				0.5	μs
Bit-Compare Time BUS, SEN/STA, TxD	t_{bc}		35	52	70	μs
Recover Time BUS, TxD	t_{rec}		30	50	75	μs
Enable Time for transmit path BUS, TxD	t_{ena}		0.92	1.33	1.8	ms
Constant-Low Time BUS, TxD	t_{low}		3	6	12	ms

Functional Diagram

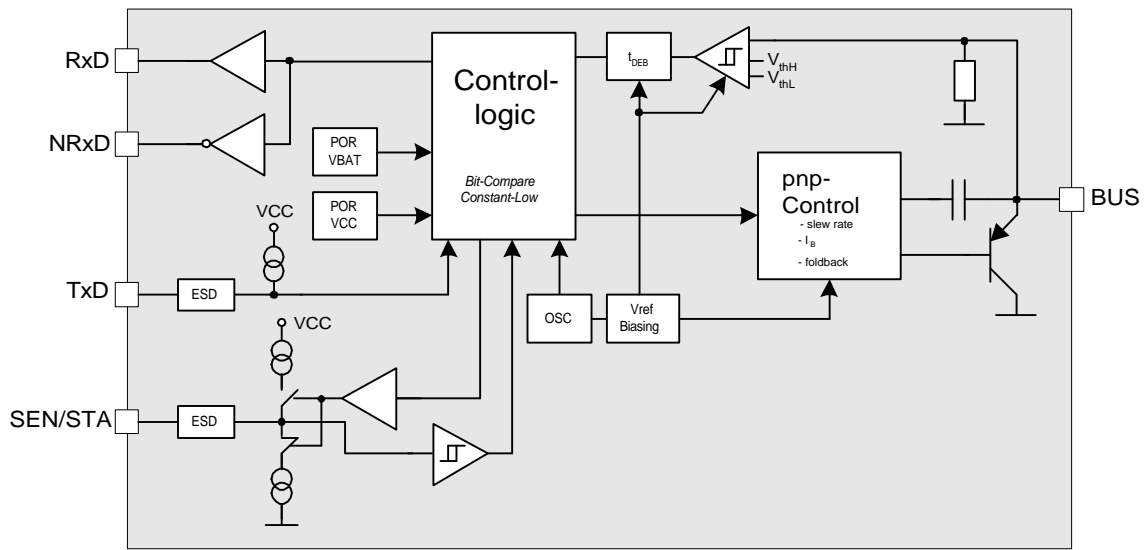

Figure 1 - Block Diagram

Functional Description

The TH3044 is used as a K-Bus interface. It builds the connection between the serial 5V bus line and the 12 V bus line. To avoid losses of data informations control functions are implemented.

Transmit

During the transmission the data at the pin TxD will be transferred to the pin RxD (NRxD) as well as to the pin BUS.

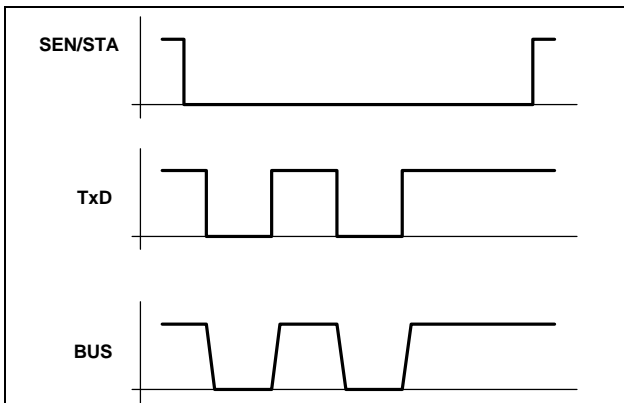

Receive

The receiving path is always transparent. Independent of the mode the pin RxD and NRxD (inverted) are related to signal at the pin BUS. Voltage spikes on the bus signal are suppressed by the implemented debouncing circuit.

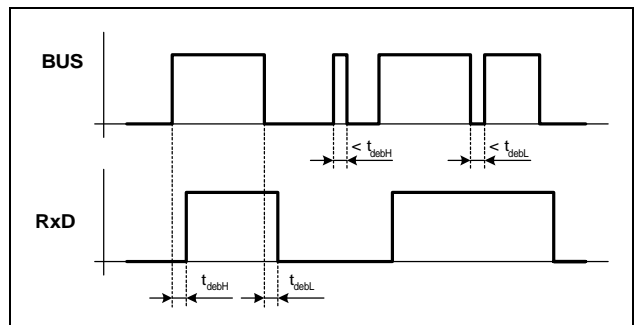

To minimise the electromagnetic emission of the bus line, the slew rate of the rising and falling edges of the data signals are limited.

Bit Compare

Are the signals at the pin TxD and the pin BUS within a specified time t_{bc} not identical, the transmission will be interrupted.

If both signals at TxD and BUS are “High” within the time t_{ena} the transmission will be enabled. To switch the TH3044 into the receive mode a low level “0” has to be applied to the pin Bus. If the TH3044 is part of a complex bus system the first device which transmits a low level “0” to the bus line forces all other TH3044 to switch into the receive mode. This state is valid until t_{ena} .

The bitcompare-function is frequently retrig-gered by every new bit-comparison of two different levels.

The bit-compare-function is activ when the pin SEN/STA is open (not overwritten).

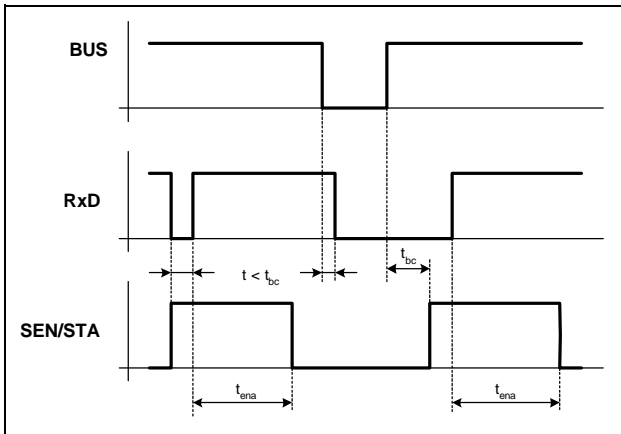

SEN/STA

The pin SEN/STA is bidirectional. Used as an output the pin indicates whether the transmit-path is enabled or disabled:

SEN/STA = "0"
transmission path is enabled

SEN/STA = "1"
transmission path is disabled

Using this pin as an input the transmission path can be overwritten (independent of bit-compare and constant-low function):

SEN/STA="0"
forcing the transmission path free

SEN/STA="1"
disable the transmission path

Constant Low

A falling edge at pin TxD (from “1” to “0”) starts the internal constant low timer.

If the low level “0” is valid for the time t_{low} the transmission unit of the TH3044 will be disabled.

The receive unit is still active. A high level “1” at TxD with a minimum pulse width of t_{rec} resets the constant low timer.

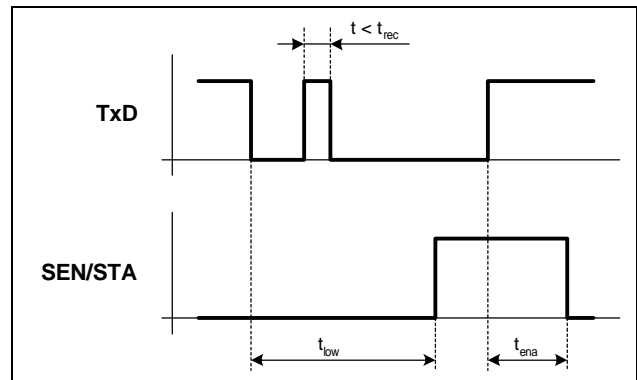

Undervoltage

Undervoltage at pin VBAT or pin VCC doesn't occur an unwanted low level at pin Bus (see chapter “Transmit”)

Application Information

Connecting Supply Pin's

Connecting VBAT, VCC and GND in random sequence does not cause damaging of the device. The absence of VBAT-, VCC- or GND-connection either alone or in any combination does not influence or disturb the bus.

Reset

The pin BUS remains in tri-state, until internal RESET state is released.

Reverse Protection

To protect the TH3044 from reverse voltages, evers protection diode needs to be connected to pin VBAT.

EMC Filter

In order to minimise EMC radiation a LC filter (22 mH, 100 pF) is recommended. As an option a RC filter (10 Ω, 100 pF) can be also used.

Application Circuit

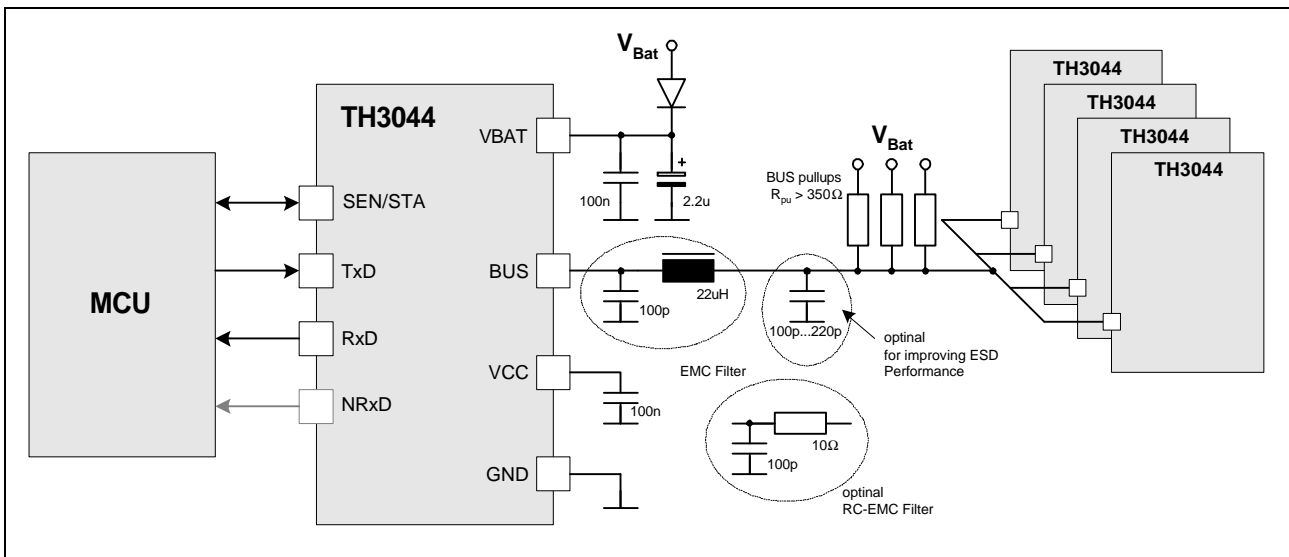

Pin Description

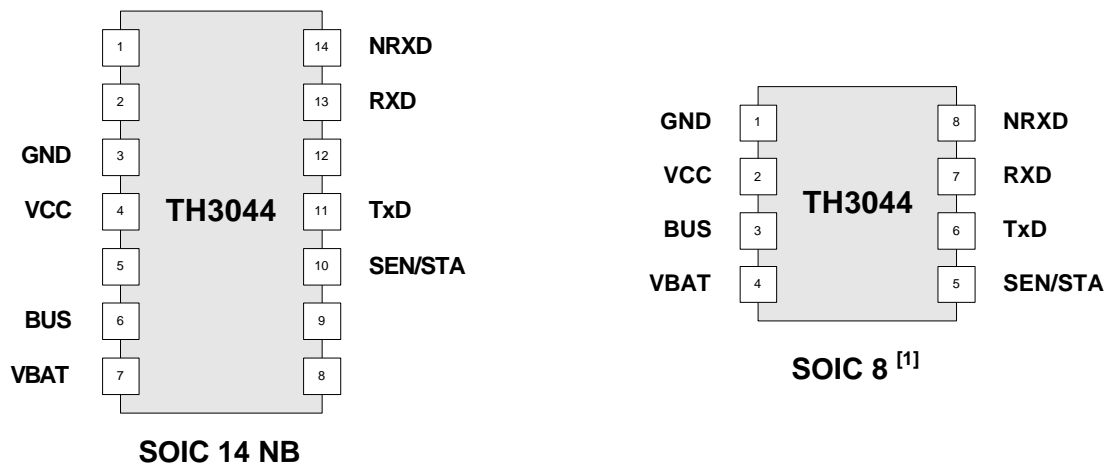

Pin SOIC14	Pin SOIC 8	Name	I/O	Function
3	1	GND	P	Ground
4	2	VCC	I	Supply Voltage 5V
6	3	BUS	I/O	K-Bus
7	4	VBAT	P	Battery Voltage
10	5	SEN/STA	I/O	Transmit Status
11	6	TXD	I	Transmit Input
13	7	RXD	O	Receive Output
14	8	NRXD	O	Inverted Receive Output

^[1] only available on request

Mechanical Specifications

SOIC8 and SOIC14B Package Dimensions

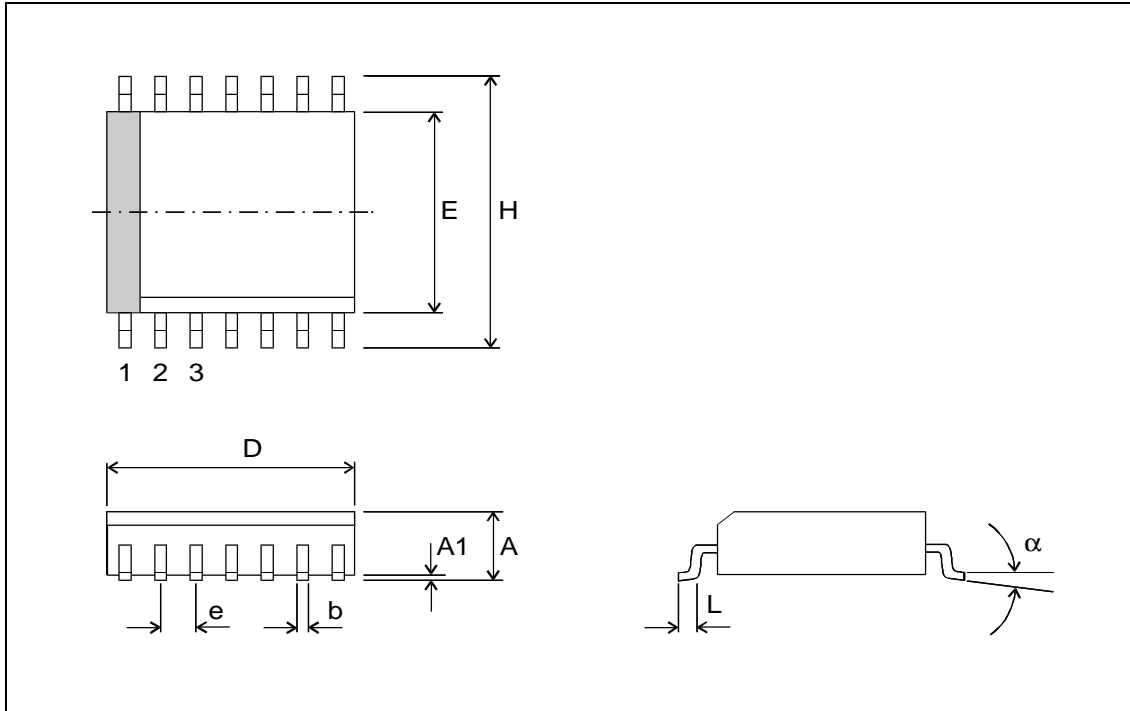

Small Outline Integrated Circuit (SOIC),

All Dimension in mm, coplanarity < 0.1 mm										
		D	E	H	A	A1	e	b	L	a
SOIC 8 150 mil	min	4.8	3.80	10.00	5.80	0.10	1.27	0.33	0.40	0°
	max	5.0	4.00	10.65	6.20	0.25				8°
SOIC 14 150 mil	min	8.55	3.80	5.80	1.35	0.10	1.27	0.33	0.40	0°
	max	8.75	4.00	6.20	1.75	0.25				8°
All Dimension in inch, coplanarity < 0.004"										
SOIC 8 150 mil	min	0.189	0.150	0.228	0.053	0.004	0.050	0.013	0.016	0°
	max	0.197	0.157	0.244	0.069	0.010				8°
SOIC 14 150 mil	min	0.337	0.150	0.228	0.053	0.004	0.050	0.013	0.016	0°
	max	0.334	0.157	0.224	0.069	0.010				8°

For the latest version of this document, go to our website at:

www.melexis.com

Or for additional information contact Melexis direct:

■ *Europe*

Phone: +32 13 67 04 95

E-mail: sales_europe@melexis.com

■ *All other locations*

Phone: +1 603 223 2362

E-mail: sales_usa@melexis.com

Important Notice

Devices sold by Melexis are covered by the warranty and patent indemnification provisions appearing in its Term of Sale. Melexis makes no warranty, express, statutory, implied, or by description regarding the information set forth herein or regarding the freedom of the described devices from patent infringement. Melexis reserves the right to change specifications and prices at any time and without notice. Therefore, prior to designing this product into a system, it is necessary to check with Melexis for current information. This product is intended for use in normal commercial applications. Applications requiring extended temperature range, unusual environmental requirements, or high reliability applications, such as military, medical life-support or life-sustaining equipment are specifically not recommended without additional processing by Melexis for each application.

The information furnished by Melexis is believed to be correct and accurate. However, Melexis shall not be liable to recipient or any third party for any damages, including but not limited to personal injury, property damage, loss of profits, loss of use, interrupt of business or indirect, special incidental or consequential damages, of any kind, in connection with or arising out of the furnishing, performance or use of the technical data herein. No obligation or liability to recipient or any third party shall arise or flow out of Melexis' rendering of technical or other services.

© 2000 Melexis GmbH. All rights reserved.
