

DATA SHEET

TEA5582

PLL stereo decoder (BTSC system)

Product specification
File under Integrated Circuits, IC02

July 1990

PLL stereo decoder (BTSC system)

TEA5582

GENERAL DESCRIPTION

The TEA5582, a 20-pin integrated phase-locked loop (PLL) stereo decoder, is designed primarily for low cost stereo decoding in a low- to medium-line TV. The MUX input (pin 1) is a low impedance current input, the gain of the input amplifier is therefore determined by the external resistor R1 (see Fig.5). All characteristics are measured with R1 = 47 k Ω . The de-emphasis of (L, R) and (L-R) can be chosen by means of external capacitors and resistors. The supply voltage range of the device is from 7 V to 16 V.

Features

- Wide supply voltage range
- Automatic mono/stereo switching (pilot presence detector)
- LED driver for stereo indicator
- Smooth mono/stereo control
- Matrix and two amplifiers for left and right output signals
- A source selector to switch between the MUX signal and an external signal
- Mute circuit for 60 dB muting of the output level
- External de-emphasis control of (L, R) and (L – R)
- 6 dB fixed attenuation of (L – R) with respect to (L + R) prior to matrix
- All pins are protected against Electrostatic Discharge (ESD)

QUICK REFERENCE DATA

| PARAMETER | CONDITIONS | SYMBOL | MIN. | TYP. | MAX. | UNIT |
|--------------------------------|--------------------------|-------------------|------|------|------|------|
| Supply voltage range | | V_S | 7.0 | 8.5 | 16 | V |
| Total current consumption | without LED driver | I_{tot} | – | 19 | 25 | mA |
| Decoder | | | | | | |
| Overall gain | mono; R1 = 47 k Ω | $G_o(V_o/V_i)$ | 4 | 5.8 | 7 | dB |
| AF output voltage (RMS value) | | $V_{14} = V_{15}$ | – | 245 | – | mV |
| Total harmonic distortion | $V_o = 600$ mV | THD | – | 0.3 | – | % |
| Output channel unbalance | | $ V_{14}/V_{15} $ | – | 0.1 | – | dB |
| Channel separation | L = 1; R = 0 | α | 24 | 28 | – | dB |
| Source selector | | | | | | |
| Suppression of MUX signal | $V_6 \geq 2$ V | α | 80 | 90 | – | dB |
| Suppression of external signal | $V_6 \leq 0.8$ V | α | 56 | 60 | – | dB |
| Output amplifiers | | | | | | |
| Gain output amplifier | | | | | | |
| MUX signal | | G_v | 6.7 | 7.2 | 7.7 | dB |
| external signal | | G_v | –0.5 | 0 | +0.5 | dB |
| AF output voltage (RMS value) | | $V_{11} = V_{10}$ | 460 | 560 | 640 | mV |
| Mute suppression | $V_7 \leq 0.8$ V | | | | | |
| MUX signal | | α | 56 | 60 | – | dB |
| external signal | | α | 56 | 60 | – | dB |

PACKAGE OUTLINE

20-LEAD DIL; PLASTIC (SOT146); SOT146-1; 1996 November 18.

PLL stereo decoder (BTSC system)

TEA5582

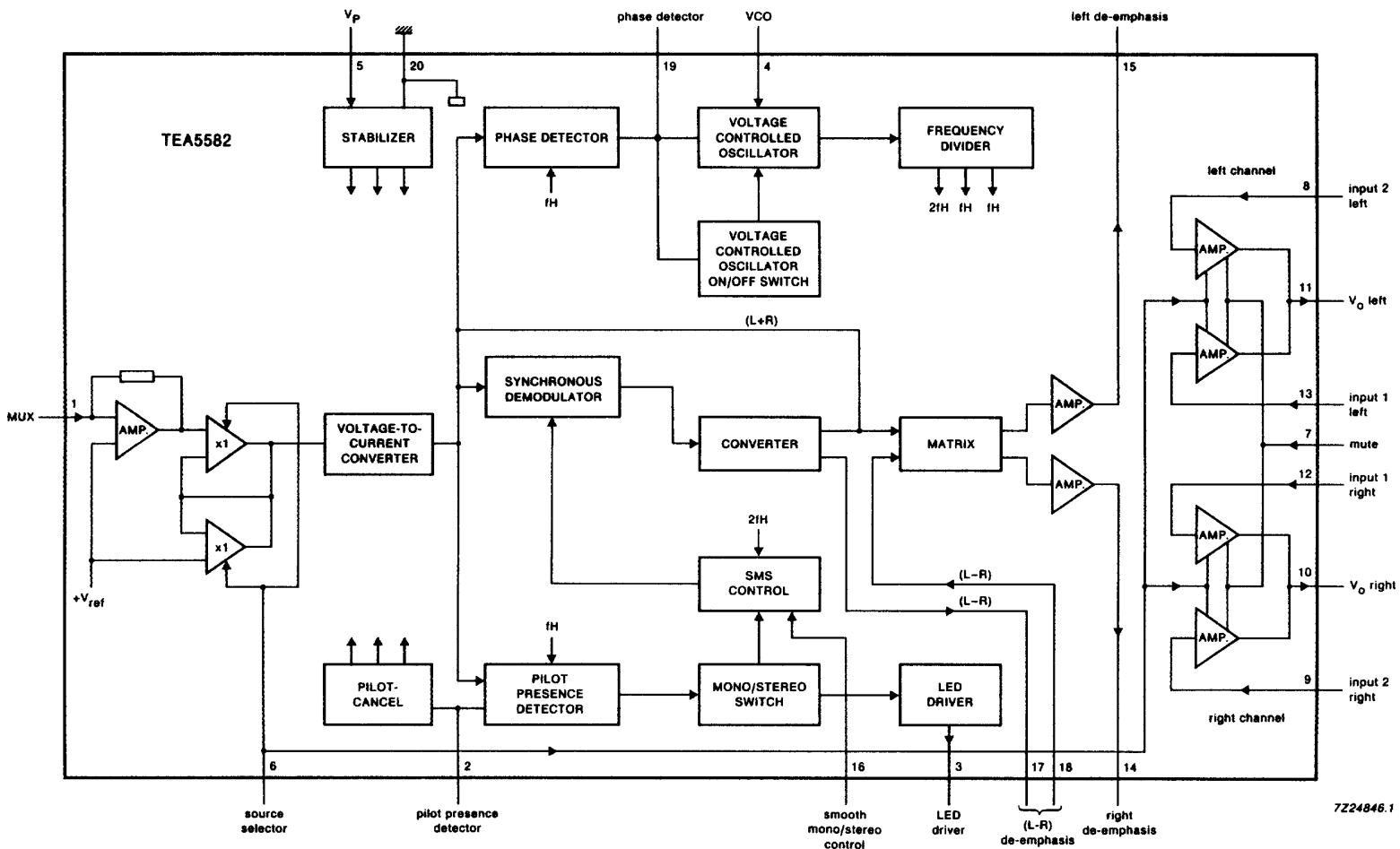

7224846.1

Fig.1 Block diagram.

PLL stereo decoder (BTSC system)

TEA5582

PINNING

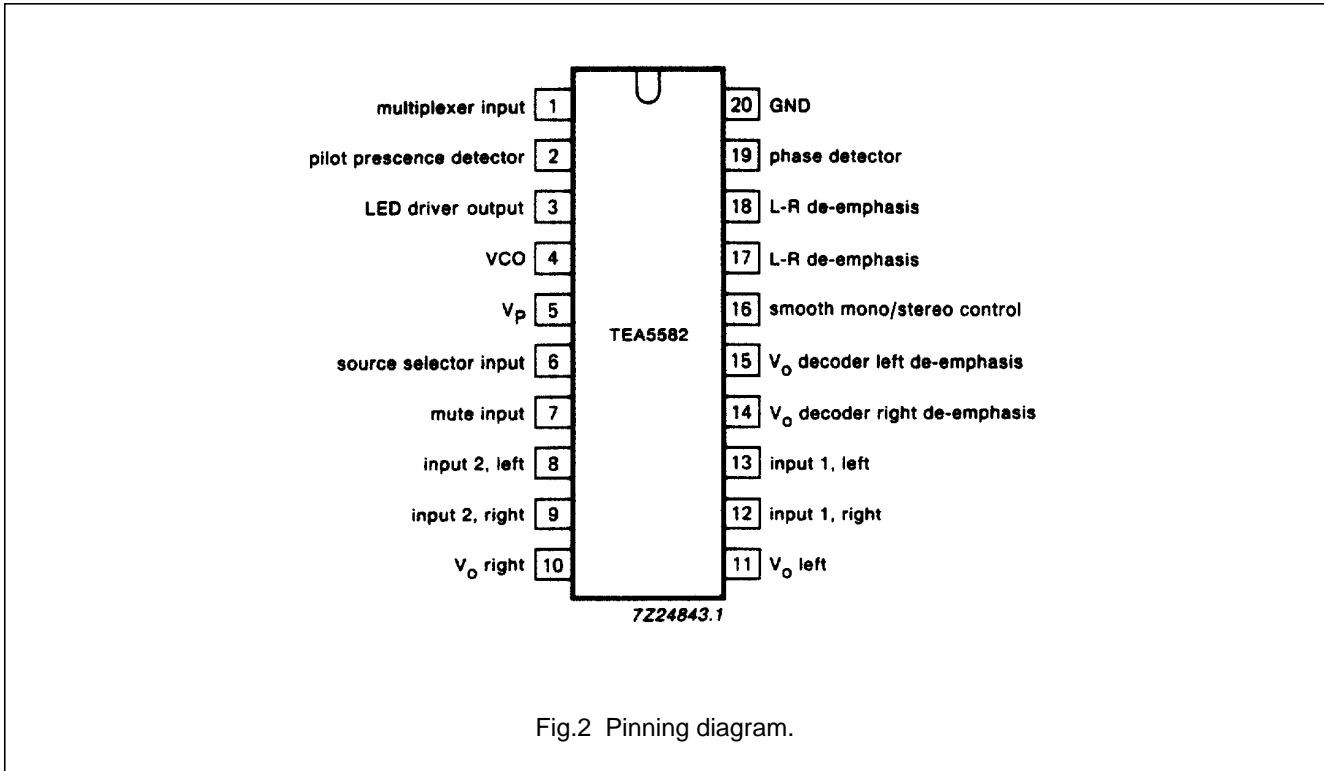

RATINGS

Limiting values in accordance with the Absolute Maximum System (IEC 134)

| PARAMETER | SYMBOL | MIN. | MAX. | UNIT |
|---------------------------------------|-----------|-----------|------|------|
| Supply voltage range (pin 5) | V_P | – | 18 | V |
| LED-driver current (peak value) | I_3 | – | 75 | mA |
| Total power dissipation | P_{tot} | see Fig.3 | | |
| Storage temperature range | T_{stg} | –65 | +150 | °C |
| Operating ambient temperature range | T_{amb} | 0 | +70 | °C |
| Electrostatic handling ⁽¹⁾ | V_{es} | –2 | +2 | kV |

Note

- ESD withstand voltage is defined by MIL STD 883C (C = 100 pF; R = 1.5 kΩ).

PLL stereo decoder (BTSC system)

TEA5582

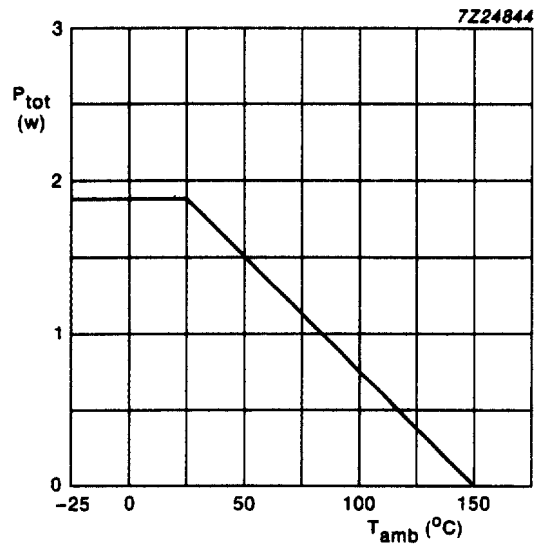

Fig.3 Power derating curve.

DC CHARACTERISTICS

All voltages are with respect to ground (pin 20); all currents are positive into the device; all parameters are measured in the test set-up (see Fig.5) at a nominal supply voltage of $V_S = 8.5$ V; $T_{amb} = 25$ °C unless otherwise specified.

| PARAMETER | CONDITIONS | SYMBOL | MIN. | TYP. | MAX. | UNIT |
|------------------------------|---------------------|-------------------|------|------|------|---------|
| Supply voltage | | V_S | 7.0 | 8.5 | 16 | V |
| Total current consumption | without LED driver | I_{tot} | – | 19 | 25 | mA |
| Power dissipation | | P_{tot} | – | 160 | – | mW |
| Voltage | | | | | | |
| pin 1 | | V_1 | – | 2.1 | – | V |
| pins 8, 9, 10, 11, 12 and 13 | | $V_8 - V_{13}$ | – | 4.2 | – | V |
| DC output current | | | | | | |
| pins 14 and 15 | | $-I_{14}, I_{15}$ | 1.1 | 1.4 | 1.8 | mA |
| LED-driver current | | | | | | |
| pin 3 | | I_3 | – | – | 20 | mA |
| Switch "VCO-OFF" | | | | | | |
| voltage | $I_{19} = 50 \mu A$ | V_{19} | – | 2 | – | V |
| Switch "VCO-OFF" | | | | | | |
| current | | I_{19} | 50 | – | – | μA |

PLL stereo decoder (BTSC system)

TEA5582

AC CHARACTERISTICS

Measured in the test circuit of Fig.5; $V_S = 8.5\text{ V}$; $T_{\text{amb}} = 25\text{ }^\circ\text{C}$.

AC conditions: (1) input signal (V_i) of 815 mV p-p for L = 1, R = 1 (mono) $f_m = 1\text{ kHz}$ (= 80% modulation). (2) MUX input signal (V_i) of 1.2 V p-p for L = 1, R = 0 and no DBX; $f_m = 1\text{ kHz}$ (stereo) and $V_{\text{pilot}} = 200\text{ mV p-p}$. (3) S1 open, unless specified (without L-R filter); voltage controlled oscillator (VCO) adjusted to 188.8 kHz at $V_i = 0\text{ V}$; values are measured with an external IF roll-off network (-2 dB at 31.5 kHz = $2f_H$) at the input (dashed components RS and CS in Fig.5). All the above conditions apply unless otherwise specified.

| PARAMETER | CONDITIONS | SYMBOL | MIN. | TYP. | MAX. | UNIT |
|---|------------------------------------|---------------------------|------|------|------|---------------|
| Overall performance (V_i to V_o) | | | | | | |
| Input current (RMS value) | | $I_{i(\text{rms})}$ | – | – | 12 | μA |
| Overall gain | mono; R1 = 47 k Ω | $G_o (V_o/V_i)$ | 4 | 5.8 | 7 | dB |
| AF output voltage (mono) (RMS value) | | $V_{11} = V_{10}$ | 460 | 560 | 640 | mV |
| AF output voltage (mono) (RMS value) | | $V_{15} = V_{14}$ | – | 245 | – | mV |
| Total harmonic distortion | note 1 | THD | – | 0.3 | 0.5 | % |
| Output voltage | THD = 1% | $V_{11} = V_{10}$ | – | 800 | – | mV |
| Output channel unbalance | | $ V_{11}/V_{10} $ | – | 0.1 | 1 | dB |
| Channel separation | L = 1; R = 0 | α | 24 | 28 | – | dB |
| Signal-to-noise ratio | bandwidth 20 Hz to 16 kHz | S/N | – | 76 | – | dB |
| | bandwidth IEC 79 (curve Din A) | S/N | – | 82 | – | dB |
| Pilot presence detector | | | | | | |
| Switching to: | note 2 | | | | | |
| stereo | | V_{pilot} | – | 40 | 60 | mV |
| mono | | V_{pilot} | 15 | 30 | – | mV |
| hysteresis | | ΔV_{pilot} | – | 2.5 | – | dB |
| Smooth mono/stereo control | | | | | | |
| (pin 16) | see Fig.4 | | | | | |
| Channel separation (α) | | | | | | |
| Full stereo | $V_{16} \geq 1.25\text{ V}$ | α | 24 | 28 | – | dB |
| Smooth operation | $V_{16} = \text{typ. } 1\text{ V}$ | α | – | 10 | – | dB |
| Full mono | $V_{16} \leq 0.75\text{ V}$ | α | – | – | 1 | dB |

PLL stereo decoder (BTSC system)

TEA5582

| PARAMETER | CONDITIONS | SYMBOL | MIN. | TYP. | MAX. | UNIT |
|---|--|------------------|------|----------------------|------|------------|
| Attenuation (L-R) | | | – | 6 | – | dB |
| Carrier and harmonic suppression at the output | note 3 | | | | | |
| Pilot signal suppression | $f_{\text{pilot}} = 15.734 \text{ kHz}$ (1 fH) | αfH | 32 | 36 | – | dB |
| Subcarrier suppression $f = 2 \text{ fH}$ | | $\alpha 2fH$ | – | 60 | – | dB |
| VCO suppression $f = 12fH$ | | $\alpha 12fH$ | – | 75 | – | dB |
| SAP signal suppression (Second Audio Programme) $f = 5fH$ | | $\alpha 5fH$ | – | 60 | – | dB |
| Intermodulation suppression $f_m = 8.367 \text{ kHz}$ | note 4 spurious signal $f_s = 1 \text{ kHz}$ | $\alpha 2$ | – | 60 | – | dB |
| $f_m = 10.823 \text{ kHz}$ | spurious signal $f_s = 1 \text{ kHz}$ | $\alpha 3$ | – | 70 | – | dB |
| Ripple rejection | $f = 120 \text{ Hz}$; $V_{\text{ripple}} = 100 \text{ mV}$; mono | RR_{120} | – | 50 | – | dB |
| VCO | | | | | | |
| R adjust (R5) | $f_{\text{OSC}} = 188.808 \text{ kHz}$ $R7 = 10 \text{ k}\Omega$ 5% $C6 = 820 \text{ pF}$ 1% | R_{adj} | 0 | – | 8 | k Ω |
| Capture range | deviation from f_{OSC} centre frequency; $V_{\text{pilot}} = 200 \text{ mV p-p}$ | $\Delta f/f$ | – | 4.5 | – | % |
| Temperature coefficient | uncompensated | TC | – | 250×10^{-6} | – | K $^{-1}$ |
| Output amplifiers | | | | | | |
| Gain | | | | | | |
| MUX signal | | G_v | 6.7 | 7.2 | 7.7 | dB |
| external signal | | G_v | –0.5 | 0 | +0.5 | dB |
| Input impedance | | Z_i | – | 50 | – | k Ω |
| Output impedance | | Z_o | – | 10 | – | Ω |
| External load impedance | | Z_1 | 10 | – | – | k Ω |
| External load capacitance | | Z_1 | – | – | 1.5 | nF |
| Mute suppression | $V_7 \leq 0.8 \text{ V}$ | | | | | |
| MUX signal | | α | 56 | 60 | – | dB |
| external signal | | α | 56 | 60 | – | dB |

PLL stereo decoder (BTSC system)

TEA5582

| PARAMETER | CONDITIONS | SYMBOL | MIN. | TYP. | MAX. | UNIT |
|--------------------------------|--------------------------------------|------------|------|------|-------|---------------|
| DC offset voltage at outputs | mute OFF-to-ON | ΔV | – | 10 | 50 | mV |
| | mute ON-to-OFF | ΔV | – | 10 | 50 | mV |
| Source selector (pin 6) | | | | | | |
| Suppression of MUX signal | $V_6 \geq 2 \text{ V}$ | α | 80 | 90 | – | dB |
| Suppression of external signal | $V_6 \leq 0.8 \text{ V}$ | α | 56 | 60 | – | dB |
| Switching level | | | | | | |
| voltage | MUX selected | V_{IL} | – | – | 0.8 | V |
| current | $V_1 = 0.8 \text{ V}$ | I_{IL} | – | 10 | 25 | μA |
| Switching level | | | | | | |
| voltage | external selected | V_{IH} | 2 | – | V_P | V |
| current | $V_1 = V_P$ | I_{IH} | – | 0.1 | 1 | μA |
| Muting circuit (pin 7) | | | | | | |
| Input voltage | mute ON | V_{IL} | – | – | 0.8 | V |
| | mute OFF | V_{IH} | 2 | – | V_P | V |
| Input current | mute ON; $V_{IL} = 0.8 \text{ V}$ | $-I_{IL}$ | – | 10 | 25 | μA |
| | mute OFF; $V_{IH} = V_P$ | I_{IL} | – | 0.1 | 1 | μA |

Notes

1. Guaranteed for mono, mono + pilot and stereo.
2. Adjustable.
3. S1 closed; reference: AF output voltage $f = 1 \text{ kHz}$ (mono).
4. Intermodulation suppression (Beat-Frequency Components (BFC)):

$$\alpha_2 = \frac{V_{o(\text{signal})} \text{ (at 1 kHz)}}{V_{o(\text{spurious})} \text{ (at 1 kHz)}}; f_s = (2 \times 8.367 \text{ kHz}) - f_H$$

$$\alpha_3 = \frac{V_{o(\text{signal})} \text{ (at 1 kHz)}}{V_{o(\text{spurious})} \text{ (at 1 kHz)}}; f_s = (3 \times 10.823 \text{ kHz}) - 2f_H$$

measured with 100% modulated input signal: $L = R$; pilot signal = 200 mV p-p; $f_m = 8.367$ or 10.823 kHz .

PLL stereo decoder (BTSC system)

TEA5582

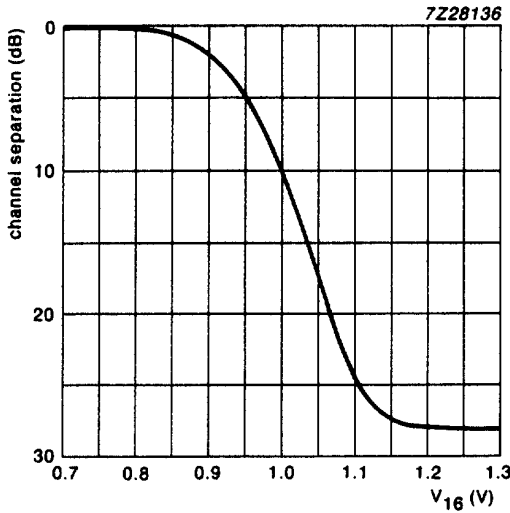

Fig.4 Smooth mono/stereo control.

PLL stereo decoder (BTSC system)

TEA5582

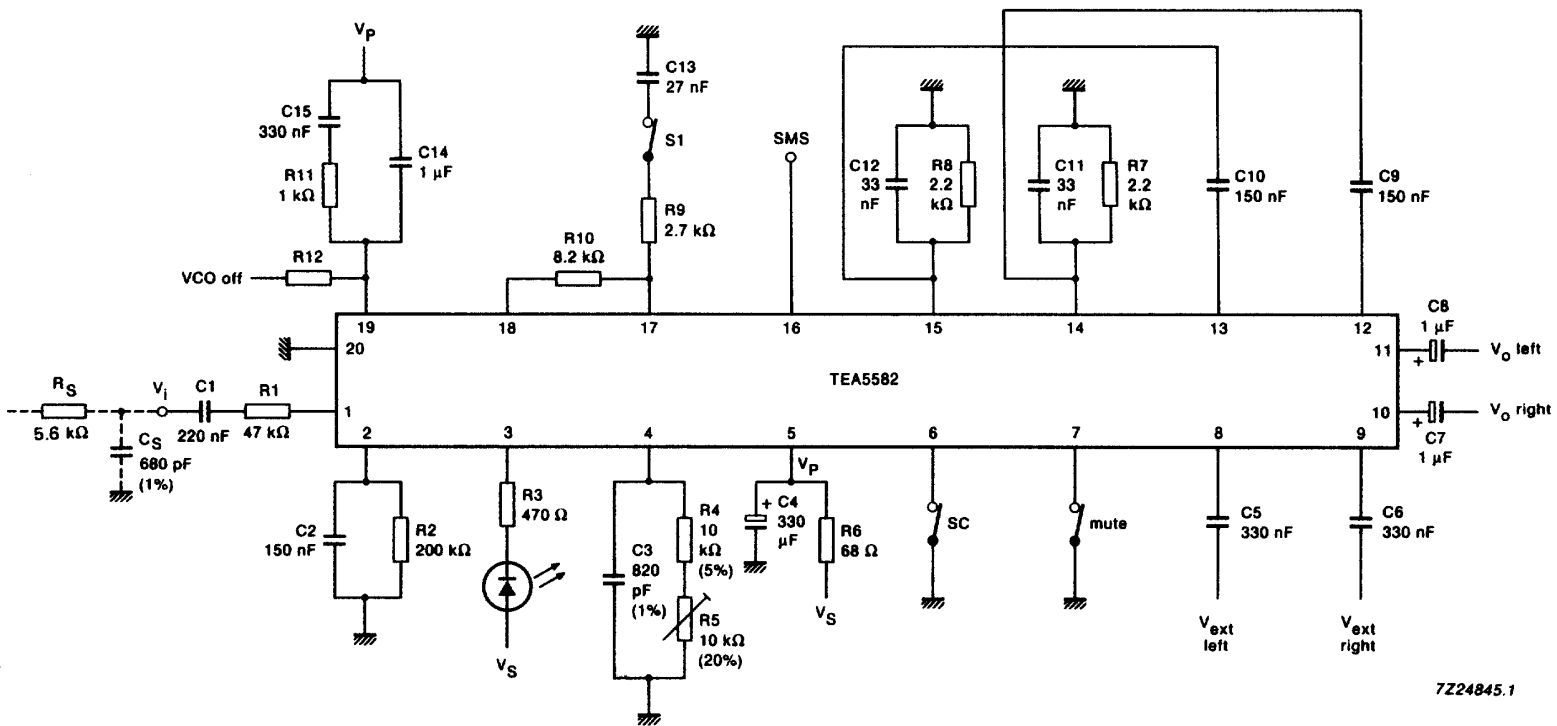

Fig.5 Test and application circuit.

PLL stereo decoder (BTSC system)

TEA5582

PACKAGE OUTLINE

DIP20: plastic dual in-line package; 20 leads (300 mil)

SOT146-1

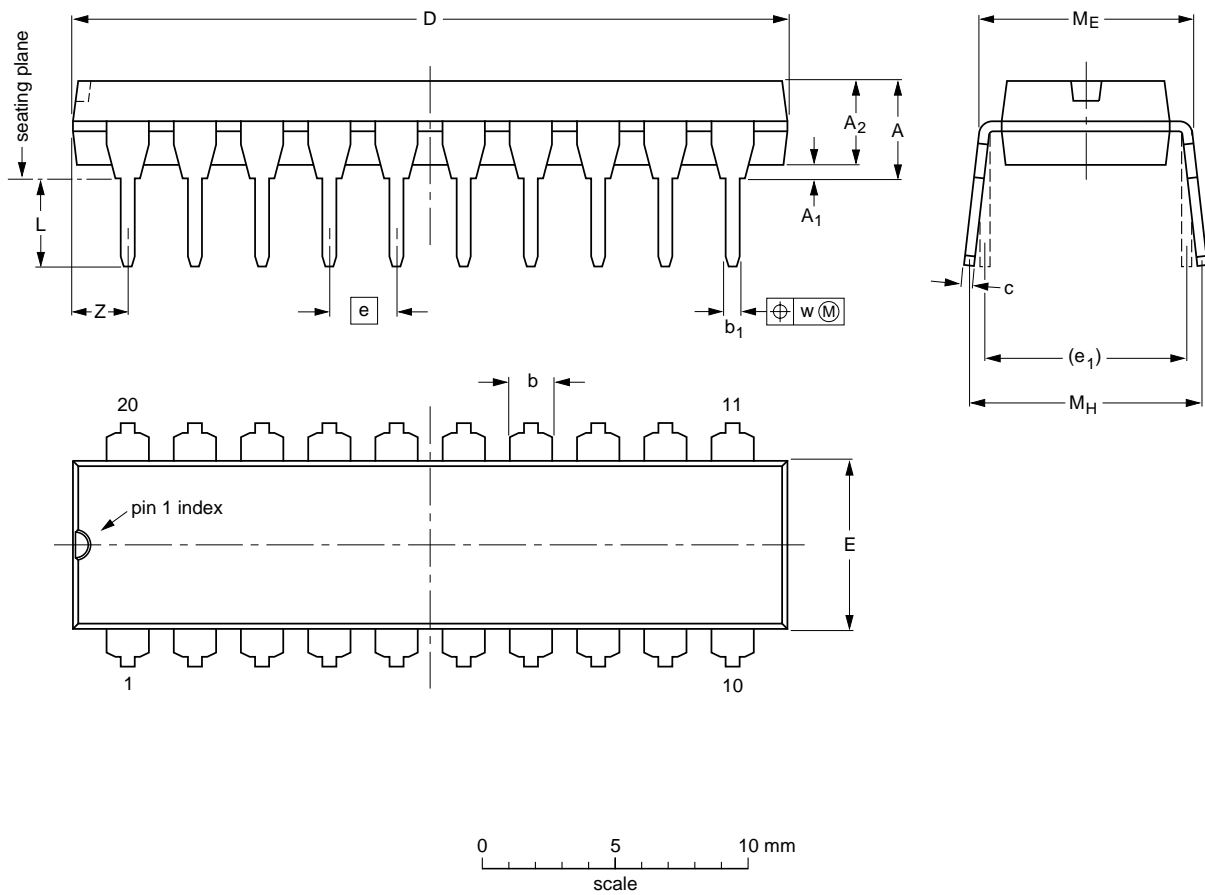

DIMENSIONS (inch dimensions are derived from the original mm dimensions)

| UNIT | A max. | A ₁ min. | A ₂ max. | b | b ₁ | c | D ⁽¹⁾ | E ⁽¹⁾ | e | e ₁ | L | M _E | M _H | w | Z ⁽¹⁾ max. |
|--------|--------|---------------------|---------------------|----------------|----------------|----------------|------------------|------------------|------|----------------|--------------|----------------|----------------|-------|-----------------------|
| mm | 4.2 | 0.51 | 3.2 | 1.73 1.30 | 0.53 0.38 | 0.36 0.23 | 26.92 26.54 | 6.40 6.22 | 2.54 | 7.62 | 3.60 3.05 | 8.25 7.80 | 10.0 8.3 | 0.254 | 2.0 |
| inches | 0.17 | 0.020 | 0.13 | 0.068 0.051 | 0.021 0.015 | 0.014 0.009 | 1.060 1.045 | 0.25 0.24 | 0.10 | 0.30 | 0.14 0.12 | 0.32 0.31 | 0.39 0.33 | 0.01 | 0.078 |

Note

1. Plastic or metal protrusions of 0.25 mm maximum per side are not included.

| OUTLINE VERSION | REFERENCES | | | | EUROPEAN PROJECTION | ISSUE DATE |
|-----------------|------------|-------|-------|--|---------------------|----------------------|
| | IEC | JEDEC | EIAJ | | | |
| SOT146-1 | | | SC603 | | | 92-11-17 95-05-24 |

PLL stereo decoder (BTSC system)

TEA5582

SOLDERING

Introduction

There is no soldering method that is ideal for all IC packages. Wave soldering is often preferred when through-hole and surface mounted components are mixed on one printed-circuit board. However, wave soldering is not always suitable for surface mounted ICs, or for printed-circuits with high population densities. In these situations reflow soldering is often used.

This text gives a very brief insight to a complex technology. A more in-depth account of soldering ICs can be found in our "IC Package Databook" (order code 9398 652 90011).

Soldering by dipping or by wave

The maximum permissible temperature of the solder is 260 °C; solder at this temperature must not be in contact with the joint for more than 5 seconds. The total contact time of successive solder waves must not exceed 5 seconds.

The device may be mounted up to the seating plane, but the temperature of the plastic body must not exceed the specified maximum storage temperature ($T_{stg\ max}$). If the printed-circuit board has been pre-heated, forced cooling may be necessary immediately after soldering to keep the temperature within the permissible limit.

Repairing soldered joints

Apply a low voltage soldering iron (less than 24 V) to the lead(s) of the package, below the seating plane or not more than 2 mm above it. If the temperature of the soldering iron bit is less than 300 °C it may remain in contact for up to 10 seconds. If the bit temperature is between 300 and 400 °C, contact may be up to 5 seconds.

DEFINITIONS

| Data sheet status | |
|---|---|
| Objective specification | This data sheet contains target or goal specifications for product development. |
| Preliminary specification | This data sheet contains preliminary data; supplementary data may be published later. |
| Product specification | This data sheet contains final product specifications. |
| Limiting values | |
| Limiting values given are in accordance with the Absolute Maximum Rating System (IEC 134). Stress above one or more of the limiting values may cause permanent damage to the device. These are stress ratings only and operation of the device at these or at any other conditions above those given in the Characteristics sections of the specification is not implied. Exposure to limiting values for extended periods may affect device reliability. | |
| Application information | |
| Where application information is given, it is advisory and does not form part of the specification. | |

LIFE SUPPORT APPLICATIONS

These products are not designed for use in life support appliances, devices, or systems where malfunction of these products can reasonably be expected to result in personal injury. Philips customers using or selling these products for use in such applications do so at their own risk and agree to fully indemnify Philips for any damages resulting from such improper use or sale.