

DATA SHEET

TDA3604Q; TDA3604TH Multiple voltage regulators with external reset delay and switch

Product specification
Supersedes data of 1997 Aug 15
File under Integrated Circuits, IC01

1997 Aug 21

Multiple voltage regulators with external reset delay and switch

**TDA3604Q;
TDA3604TH**

FEATURES

General

- One V_P -state controlled regulator (regulator 2)
- Regulator 2, reset and ignition buffer operate during load dump and thermal shutdown
- Separate control pins for switching regulator 1 and the power switch
- Supply voltage range of -18 to $+50$ V (operating from 9.75 V)
- Low reverse current of regulator 2
- Low quiescent current (when regulator 1, power switch and ignition buffer are switched off)
- Ignition input/output
- Reset output
- Adjustable reset delay time
- High ripple rejection
- Power switch
- Separate supply for the power switch.

Protections

- Reverse polarity safe (down to -18 V without high reverse current)
- Able to withstand voltages up to 18 V at the outputs (supply line may be short-circuited)
- ESD protected on all pins
- Thermal protection
- Load dump protection
- Foldback current limit protection for regulators 1 and 2
- Delayed second current limit protection for the power switch
- The regulator outputs and the power switch are DC short-circuited safe to ground and V_P .

GENERAL DESCRIPTION

The TDA3604Q and TDA3604TH are multiple output voltage regulators with a power switch, intended for use in car radios with or without a microcontroller.

It contains one fixed voltage regulator with a foldback current protection (regulator 1) and one fixed voltage regulator (regulator 2), intended to supply a microcontroller, that also operates during load dump and thermal shutdown.

There is a power switch with protections, operated by an enable input.

The reset and ignition outputs can be used to interface by the microcontroller. The reset signal can be used to call up the microcontroller and the ignition output indicates ignition voltage available.

Both supply pins can withstand load dump pulses and negative supply voltages.

Regulator 2 will be switched on at a supply voltage >6.5 V and off at a voltage of regulator 2 <1.9 V.

ORDERING INFORMATION

TYPE NUMBER	PACKAGE		
	NAME	DESCRIPTION	VERSION
TDA3604Q	DBS13P	plastic DIL-bent-SIL power package; 13 leads (lead length 12 mm)	SOT141-6
TDA3604TH	HSOP20	plastic heat-dissipating small outline package; 20 leads; low stand-off	SOT418-2

Multiple voltage regulators with external reset delay and switch

TDA3604Q; TDA3604TH

QUICK REFERENCE DATA

SYMBOL	PARAMETER	CONDITIONS	MIN.	TYP.	MAX.	UNIT
Supply						
V_P	supply voltage		9.75	14.4	25	V
	operating regulator 2 on	note 1	2.4	14.4	25	V
	jump start	$t \leq 10$ minutes	–	–	30	V
	load dump protection	during 50 ms; $t_r \geq 2.5$ ms	–	–	50	V
I_q	total quiescent current	standby mode	–	400	500	μA
T_{vj}	operating virtual junction temperature		–	–	150	$^{\circ}\text{C}$
Voltage regulators						
V_{REG1}	output voltage regulator 1	$0.5 \text{ mA} \leq I_{REG1} \leq 300 \text{ mA}$	8.65	9.0	9.35	V
V_{REG2}	output voltage regulator 2	$0.5 \text{ mA} \leq I_{REG2} \leq 50 \text{ mA}$; $V_P = 14.4 \text{ V}$	4.8	5.0	5.2	V
V_{REGd1}	drop-out voltage regulator 1	$I_{REG1} = 0.3 \text{ A}$; note 2	–	–	0.5	V
Power switch						
V_{swd}	drop-out voltage	$I_{sw} = 0.5 \text{ A}$; note 3	–	–	1.4	V
I_{swM}	peak current	$t \leq 10 \text{ ms}$	1.4	–	–	A

Notes

1. Minimum operating voltage, only if V_P has exceeded 6.5 V.
2. The drop-out voltage of regulator 1 is measured between V_P and V_{REG1} .
3. The drop-out voltage of the power switch is measured between $V_{I(sw)}$ and $V_{O(sw)}$.

Multiple voltage regulators with external reset delay and switch

TDA3604Q; TDA3604TH

BLOCK DIAGRAM

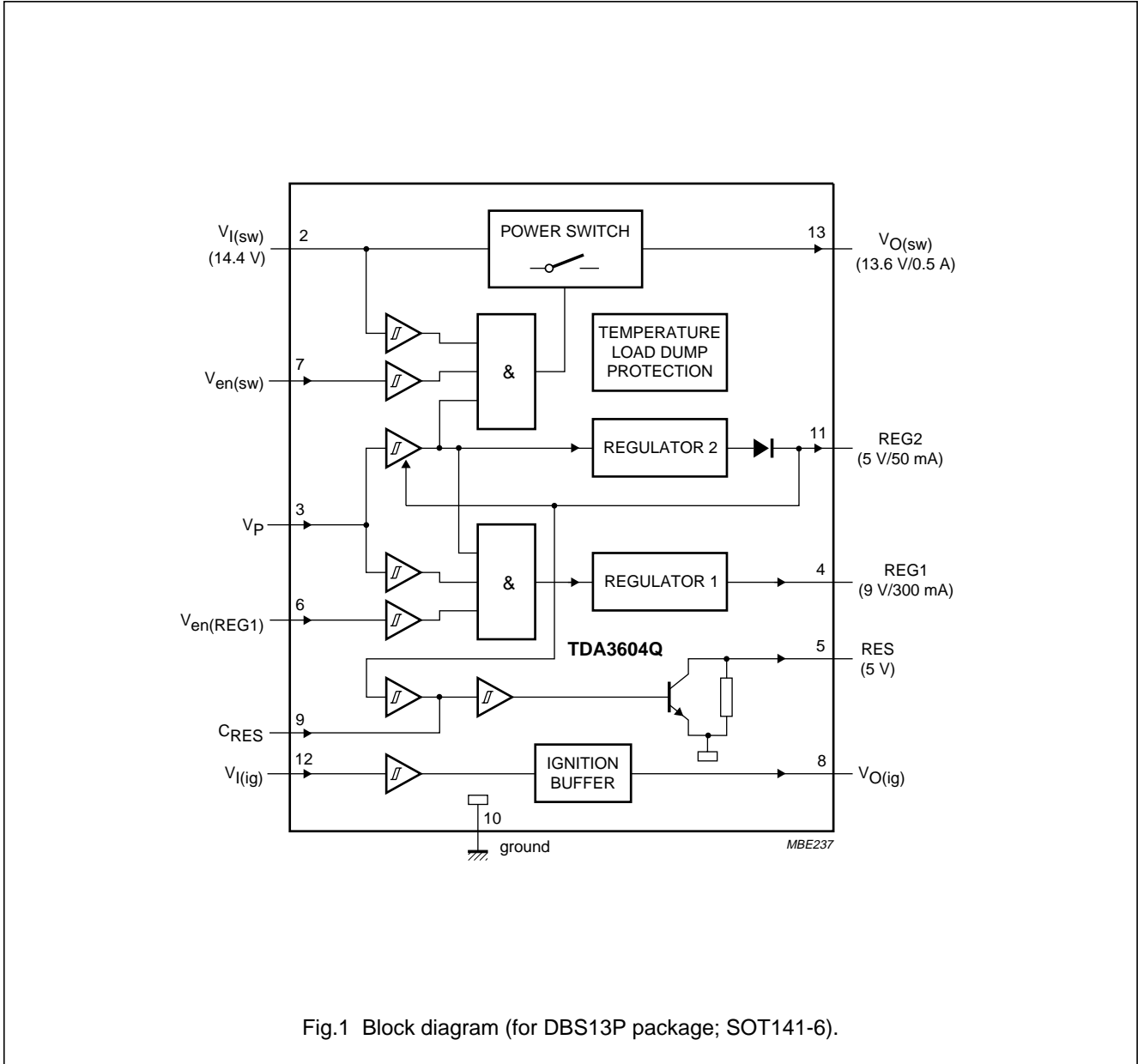

Fig.1 Block diagram (for DBS13P package; SOT141-6).

Multiple voltage regulators with external reset delay and switch

TDA3604Q; TDA3604TH

PINNING

SYMBOL	PIN		DESCRIPTION
	SOT141-6	SOT418-2	
n.c.	1	1, 2, 6, 9, 13, 18, 19 and 20	not connected
$V_{I(sw)}$	2	3	power switch input
V_P	3	4	supply voltage
REG1	4	5	regulator 1 output
RES	5	7	reset output (+5 V)
$V_{en(REG1)}$	6	8	regulator 1 enable input
$V_{en(sw)}$	7	10	power switch enable input
$V_{O(ig)}$	8	11	ignition output
C_{RES}	9	12	reset delay capacitor
GND	10	14	ground (0 V)
REG2	11	15	regulator 2 output
$V_{I(ig)}$	12	16	ignition input
$V_{O(sw)}$	13	17	power switch output

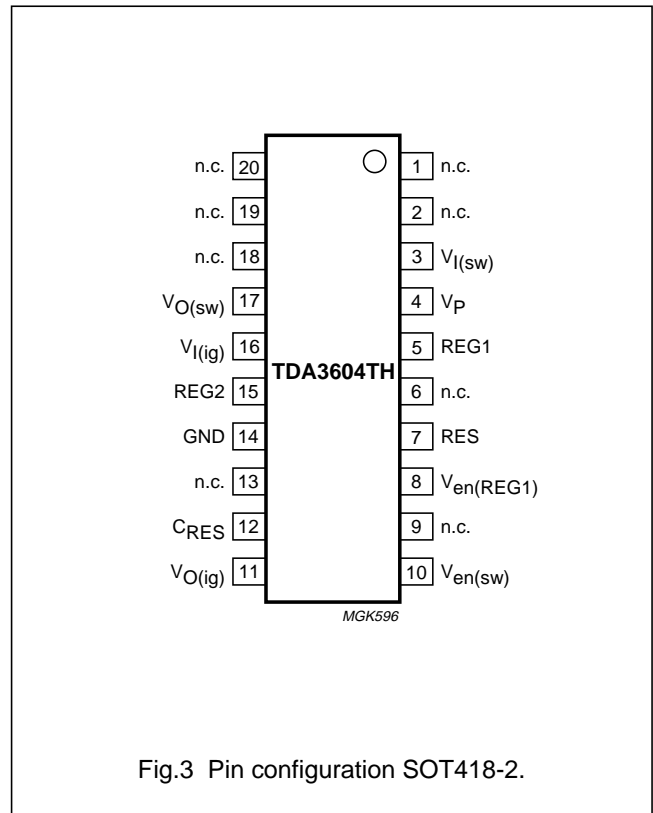
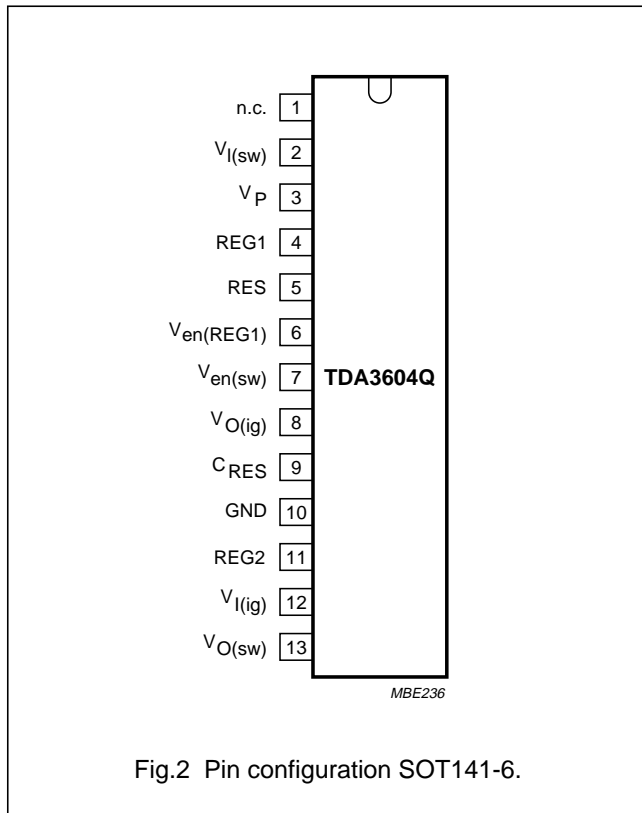

Multiple voltage regulators with external reset delay and switch

TDA3604Q; TDA3604TH

FUNCTIONAL DESCRIPTION

The TDA3604Q and TDA3604TH are multiple output voltage regulators with a power switch, intended for use in car radios with or without a microcontroller. Because of low-voltage operation of the car radio, low-voltage drop regulators are used.

Regulator 2 will switch on when the supply voltage exceeds 6.5 V for the first time and will switch off again when the output voltage of regulator 2 drops below 1.9 V (this is below an engine start). When regulator 2 is switched on and the output voltage of this regulator is within its voltage range, the reset output will be enabled (reset will go HIGH via a pull-up resistor) to generate a reset to the microcontroller. The reset cycles can be extended by an external capacitor at C_{RES} (pin of the reset delay capacitor). The above mentioned start-up feature is built-in to secure a smooth start-up of the microcontroller at first connection, without uncontrolled switching of regulator 2 during the start-up sequence.

When both regulator 2 and the supply voltage ($V_P > 4.5$ V) are available, regulator 1 and the power switch can be operated by the enable inputs $V_{en(REG1)}$ and $V_{en(sw)}$ respectively.

All output pins are fully protected. The regulators are protected against load dump (regulator 1 will switch off at supply voltages higher than 25 V) and short-circuit (foldback current protection).

The power switch contains a current protection which is delayed for ≥ 10 ms (in short-circuit condition). During this time the current is limited to 1.4 A ($V_P \leq 18$ V).

At supply voltages over 16.9 V the power switch is clamped at 15.0 V (to avoid externally connected circuitry being damaged by an overvoltage) and the power switch will switch off at load dump.

Interfacing with the microcontroller can be accomplished by an ignition Schmitt trigger and ignition output buffer, (simple full/semi on/off logic applications).

The total timing of a semi on/off logic set is shown in Fig.4.

Multiple voltage regulators with external reset delay and switch

TDA3604Q; TDA3604TH

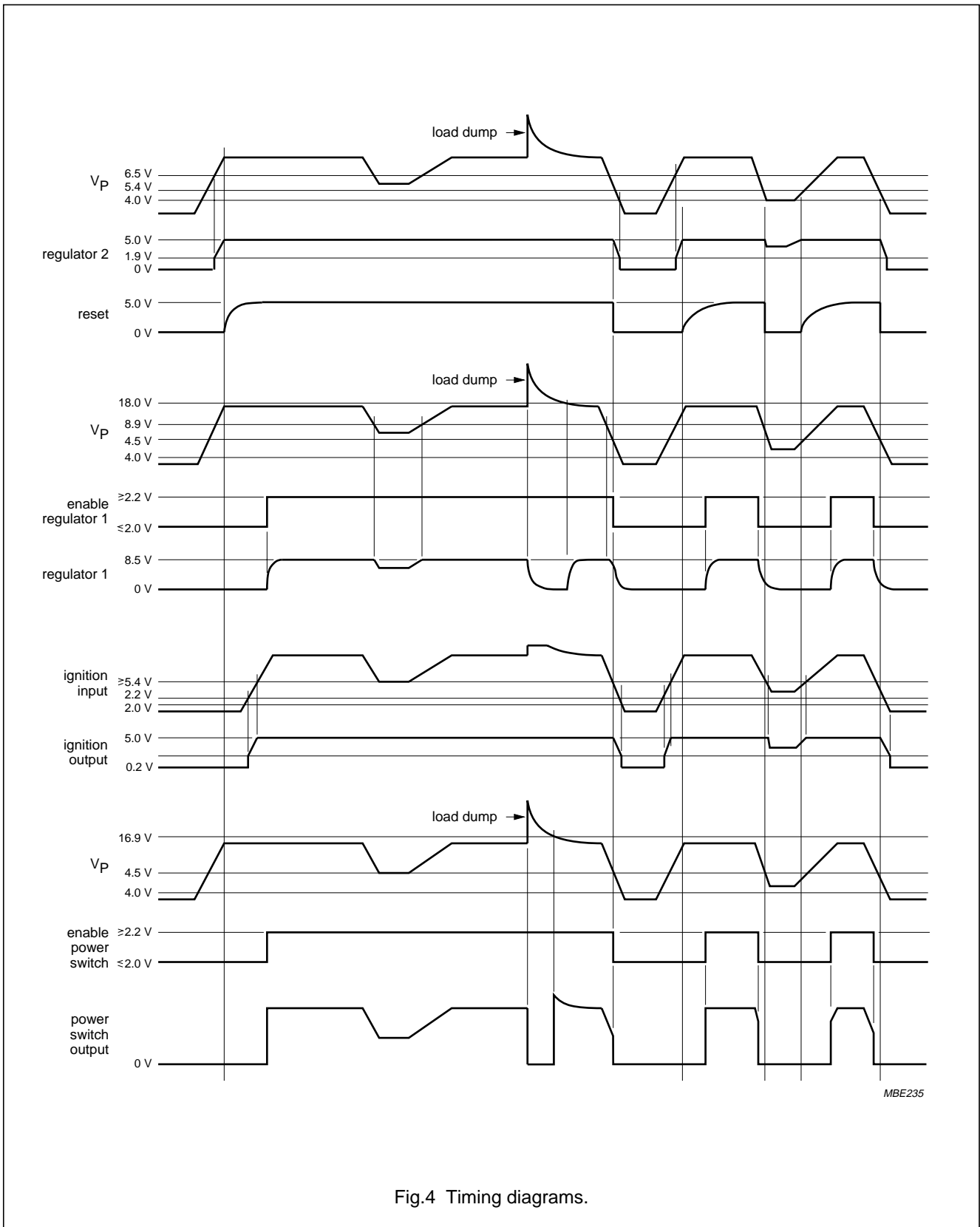

Fig.4 Timing diagrams.

Multiple voltage regulators with external reset delay and switch

TDA3604Q; TDA3604TH

LIMITING VALUES

In accordance with the Absolute Maximum Rating System (IEC 134).

SYMBOL	PARAMETER	CONDITIONS	MIN.	MAX.	UNIT
V _P	supply voltage				
	operating		–	25	V
	reverse polarity	non-operating	–	–18	V
	jump start	t ≤ 10 minutes	–	30	V
	load dump protection	during 50 ms; t _r ≥ 2.5 ms	–	50	V
V _{ppi}	positive pulse voltage at ignition buffer	V _P = 14.4 V; R _I = 1 kΩ	–	50	V
V _{npi}	negative pulse voltage at ignition buffer	V _P = 14.4 V; R _I = 1 kΩ	–	–100	V
T _{stg}	storage temperature	non-operating	–55	+150	°C
T _{vj}	operating virtual junction temperature		–40	+150	°C
P _{tot}	total power dissipation		–	15.6	W

THERMAL CHARACTERISTICS

SYMBOL	PARAMETER	VALUE	UNIT
R _{th j-c}	thermal resistance from junction to case	8	K/W
R _{th j-a}	thermal resistance from junction to ambient in free air	50	K/W

Multiple voltage regulators with external reset delay and switch

TDA3604Q; TDA3604TH

CHARACTERISTICS

$V_P = V_{I(sw)} = 14.4 \text{ V}$; $T_{amb} = 25 \text{ }^\circ\text{C}$; see Fig.7; unless otherwise specified.

SYMBOL	PARAMETER	CONDITIONS	MIN.	TYP.	MAX.	UNIT
Supply						
V_P	supply voltage		9.75	14.4	25	V
	operating regulator 2 on	note 1	2.4	14.4	25	V
	jump start	$t \leq 10$ minutes	–	–	30	V
	load dump protection	during 50 ms; $t_r \geq 2.5$ ms	–	–	50	V
I_q	quiescent supply current	$V_P = 12.4 \text{ V}$; note 2	–	400	500	μA
		$V_P = 14.4 \text{ V}$; note 2	–	420	–	μA
Schmitt trigger power supply for the power switch						
V_{thr}	rising threshold voltage		4.0	4.5	5.0	V
V_{thf}	falling threshold voltage		3.5	4.0	4.5	V
V_{hys}	hysteresis voltage		–	0.5	–	V
Schmitt trigger power supply for regulator 1						
V_{thr}	rising threshold voltage		4.0	4.5	5.0	V
V_{thf}	falling threshold voltage		3.5	4.0	4.5	V
V_{hys}	hysteresis voltage		–	0.5	–	V
Schmitt trigger for regulator 2						
V_{thr}	rising threshold voltage		6.0	6.5	7.1	V
V_{thf}	falling threshold voltage		1.7	1.9	2.2	V
V_{hys}	hysteresis voltage		–	4.7	–	V
Schmitt trigger for enable input (of regulator 1 and power switch)						
V_{thr}	rising threshold voltage		1.7	2.2	2.7	V
V_{thf}	falling threshold voltage		1.5	2.0	2.5	V
V_{hys}	hysteresis voltage		–	0.2	–	V
Schmitt trigger for reset buffer						
$V_{r(REG2)}$	rising voltage of regulator 2	note 3	–	$V_{REG2} - 0.15$	–	V
$V_{f(REG2)}$	falling voltage of regulator 2	note 3	–	$V_{REG2} - 0.25$	–	V
V_{spread}	voltage spread on tracking	note 4	–	10	–	mV
Schmitt trigger for ignition buffer						
V_{thr}	rising threshold voltage		1.7	2.2	2.7	V
V_{thf}	falling threshold voltage		1.5	2.0	2.5	V
V_{hys}	hysteresis voltage		–	0.2	–	V
Reset buffer						
I_{sink}	LOW-level sink current	$V_{RES} \leq 0.8 \text{ V}$	15	20	–	mA
I_{leak}	leakage current	$V_P = 14.4 \text{ V}$; $V_{RES} = 5 \text{ V}$	25	50	100	μA

Multiple voltage regulators with external reset delay and switch

TDA3604Q; TDA3604TH

SYMBOL	PARAMETER	CONDITIONS	MIN.	TYP.	MAX.	UNIT
Ignition buffer						
V_{OL}	LOW-level output voltage	$I_{OL} = 0$	0	0.2	0.8	V
V_{OH}	HIGH-level output voltage	note 5	–	5.0	5.2	V
I_{OL}	LOW-level output current	$V_{OL} \leq 0.8$ V	0.3	0.8	–	mA
I_{OH}	HIGH-level output current	$V_{OH} \geq 3$ V	0.3	2.0	–	mA
Regulator 1; note 6						
V_{REG1}	output voltage off		–	1	400	mV
V_{REG1}	output voltage	$0.5 \text{ mA} \leq I_{REG1} \leq 300 \text{ mA}$	8.65	9.0	9.35	V
		$10 \text{ V} \leq V_P \leq 18 \text{ V}$	8.65	9.0	9.35	V
ΔV_{REG1}	line regulation	$10 \text{ V} \leq V_P \leq 18 \text{ V}$	–	–	50	mV
ΔV_{REGL1}	load regulation	$0.5 \text{ mA} \leq I_{REG1} \leq 300 \text{ mA}$	–	–	70	mV
SVRR1	supply voltage ripple rejection	$f_i = 200 \text{ Hz}; V_i = 2 \text{ V (p-p)}$	60	–	–	dB
V_{REGd1}	drop-out voltage	$I_{REG1} = 300 \text{ mA};$ note 7	–	0.4	0.5	V
I_{REGm1}	current limit	$V_{REG1} > 7 \text{ V};$ note 8	0.45	–	1.2	A
I_{REGsc1}	short-circuit current	$R_L \leq 0.5 \Omega;$ note 9	50	300	–	mA
α_{ct}	cross talk	note 10	–	50	–	dB
Regulator 2; note 11						
V_{REG2}	output voltage	$0.5 \text{ mA} \leq I_{REG2} \leq 50 \text{ mA}$	4.8	5.0	5.2	V
		$7 \text{ V} \leq V_P \leq 18 \text{ V}$	4.8	5.0	5.2	V
		$18 \text{ V} \leq V_P \leq 50 \text{ V}$	4.75	5.0	5.25	V
ΔV_{REG2}	line regulation	$7 \text{ V} \leq V_P \leq 18 \text{ V}$	–	–	50	mV
ΔV_{REGL2}	load regulation	$0.5 \text{ mA} \leq I_{REG1} \leq 30 \text{ mA}$	–	–	50	mV
SVRR2	supply voltage ripple rejection	$f_i = 200 \text{ Hz}; V_i = 2 \text{ V (p-p)}$	60	–	–	dB
V_{REGd2}	drop-out voltage	$I_{REG2} = 30 \text{ mA};$ note 12	–	0.3	0.4	V
I_{REGm2}	current limit	$V_{REG2} > 4.5 \text{ V};$ note 8	0.1	–	0.5	A
I_{REGsc2}	short-circuit current	$R_L \leq 0.5 \Omega;$ note 9	20	50	–	mA
α_{ct}	cross talk	note 13	–	50	–	dB
Power switch						
V_{swd}	drop-out voltage	$I_{sw} = 0.5 \text{ A};$ note 14	–	0.8	1.4	V
I_{swcc}	continuous current		0.5	–	–	A
V_{swcl}	clamping voltage	$V_P \geq 16.9 \text{ V}$	–	15.0	16.2	V
I_{swM}	peak current	$t \leq 10 \text{ ms}$	1.4	–	–	A
V_{swfb}	fly back voltage behaviour	$I_{sw} = -200 \text{ mA}; V_P = 9 \text{ V}$	–	–	20	V
$I_{lim(sw)}$	current limit	$V_P = 14.4 \text{ V}; V_{sw} < 1.5 \text{ V};$ note 8	0.6	0.9	–	A
Reset delay						
I_o	output current		–	3	–	μA
V_{thr}	rising threshold voltage		2.7	3.0	3.3	V
t_d	delay time	$C_I = 47 \text{ nF};$ note 15	25	50	100	ms

Multiple voltage regulators with external reset delay and switch

TDA3604Q; TDA3604TH

Notes to the characteristics

1. Minimum operating voltage, only if V_P has exceeded 6.5 V.
2. Enable inputs of regulator 1, ignition and power switch are low. Regulator 2 is unloaded.
3. Voltage drop due to load condition.
4. The spread on tracking is one sigma value.
5. Ignition output voltage will be less than or equal to the output voltage of regulator 2.
6. $I_{REG1} = 5$ mA unless otherwise specified.
7. The drop-out voltage of regulator 1 is measured between V_P and V_{REG1} .
8. At current limit, I_{REGm} is held constant (see Fig.5).
9. The foldback current protection limits the dissipated power at short-circuit (see Figs 5 and 6).
10. The cross talk of regulator 1 is measured with an $I_{REG2} = 0.5$ mA up to 30 mA and input frequency of $f_i = 100$ kHz.
11. $I_{REG2} = 5$ mA unless otherwise specified.
12. The drop-out voltage of regulator 2 is measured between V_P and V_{REG2} .
13. The cross talk of regulator 2 is measured with an $I_{REG1} = 0.5$ mA up to 100 mA and input frequency of $f_i = 100$ kHz.
14. The drop-out voltage of the power switch is measured between $V_{I(sw)}$ and $V_{O(sw)}$.
15. The delay time depends on the value of the capacitor: $t_d = \frac{C}{I} \times V_{thrC} = C \times 2.5 \times 10^6$

Multiple voltage regulators with external reset delay and switch

TDA3604Q; TDA3604TH

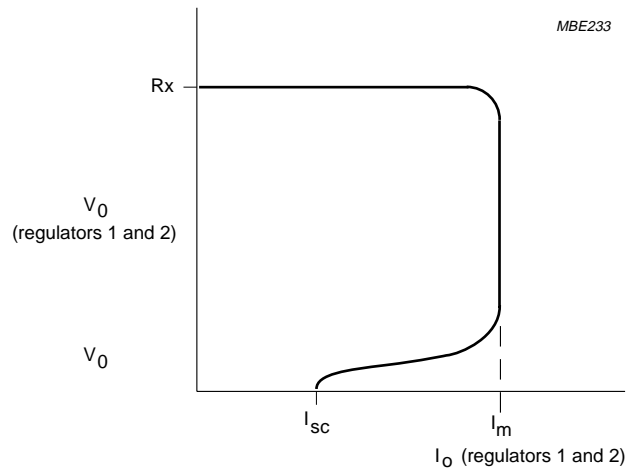

Fig.5 Foldback current protection of the regulators.

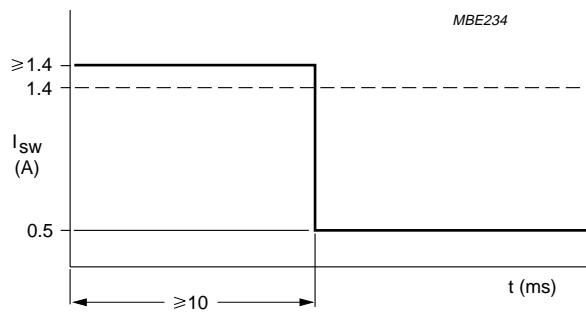
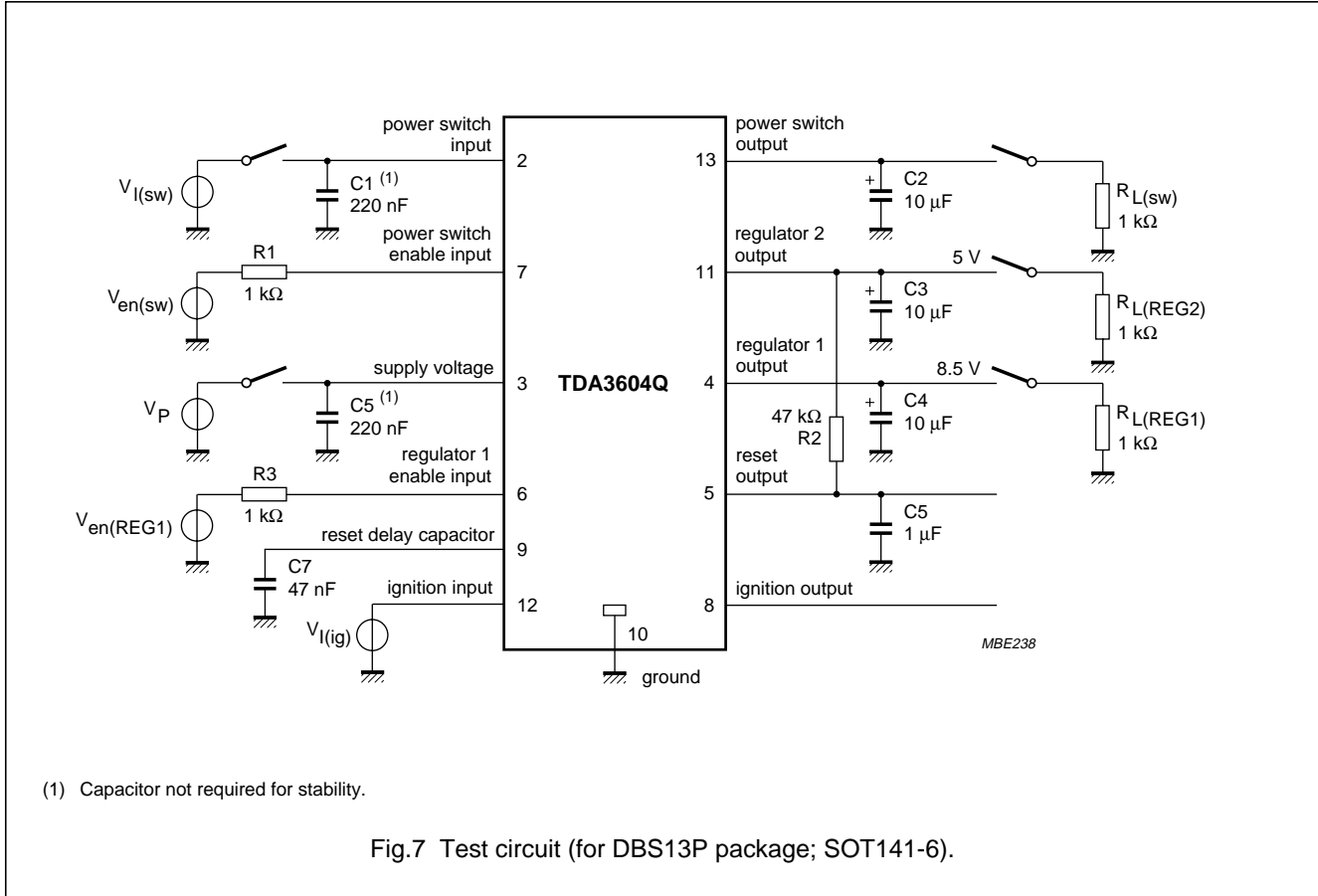

Fig.6 Foldback current protection of the power switch.

Multiple voltage regulators with external reset delay and switch

TDA3604Q; TDA3604TH

TEST AND APPLICATION INFORMATION



Noise information

The noise at the output of the regulators depends on the bandwidth of the regulators, which can be adjusted by the output capacitors. Table 1 shows the noise figures.

Although stability is guaranteed when C_L is higher than 10 μF (over temperature range) with $\tan(\phi) = 1$ in the frequency range 1 to 10 kHz, however, for low noise, a 47 μF load capacitor is required.

The noise on the supply line depends on the value of the supply capacitor and is caused by a current noise (output noise of the regulators is translated into a current noise by the output capacitors). When a high frequency capacitor of 220 nF with an electrolytic capacitor of 100 μF in parallel is placed directly over V_P and GND (pins of supply voltage and ground) the noise is minimized.

Table 1 Noise figures

REGULATOR	NOISE (μV) ⁽¹⁾	OUTPUT CAPACITOR (μF)
1	180	10
	100	47
	80	100
2	120	10
	70	47
	70	100

Note

1. Bandwidth of 100 kHz.

Multiple voltage regulators with external reset delay and switch

TDA3604Q; TDA3604TH

SHORT CIRCUIT BEHAVIOUR OF POWER SWITCH

The short circuit behaviour of the switch with large inductive loads (switch output goes out of the radio) can be improved by replacing C2 (see Fig.7) by a larger electrolytic capacitor of 10 μ F/16 V. When the temperature protection of the switch becomes active, due to a short circuit of the switch, the behaviour will be improved.

When the switch is clamped an minimum output capacitor of 10 μ F is needed.

The power switch is not protected against 'loss of ground' condition (= short of the switch to ground with floating ground pin of the TDA3604 itself). A 'loss of ground' situation can in practice only occur when the switch output goes outside the car-radio box.

There is an application solution to protect against 'loss of ground' (see Fig.8).

It is advisable to limit the dissipation at short circuit condition by monitoring the output of the power switch. The microprocessor can switch of the power switch when the switch was enabled and the switch output remains low due to a short circuit condition.

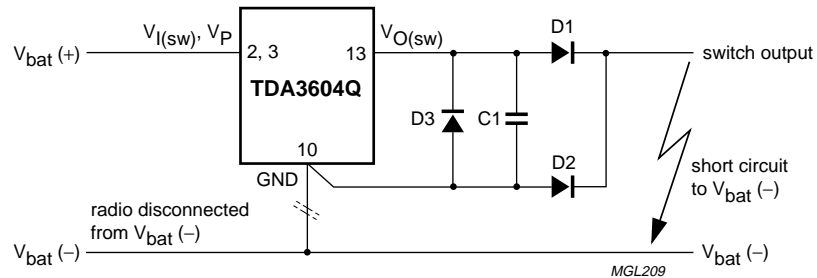

Fig.8 'Loss of ground' protection.

Multiple voltage regulators with external reset delay and switch

TDA3604Q; TDA3604TH

PACKAGE OUTLINES

DBS13P: plastic DIL-bent-SIL power package; 13 leads (lead length 12 mm)

SOT141-6

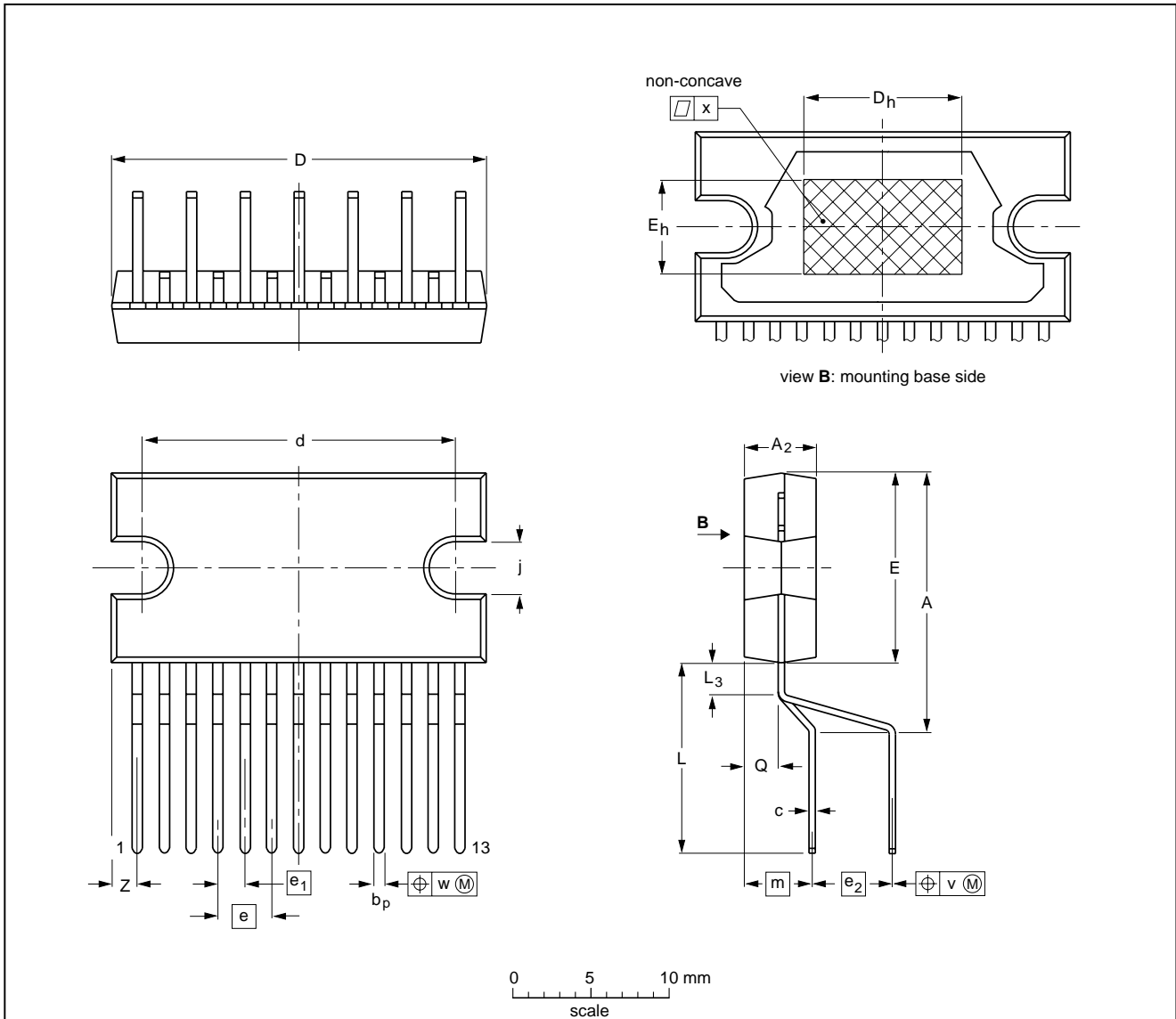

DIMENSIONS (mm are the original dimensions)

UNIT	A	A ₂	b _p	c	D ⁽¹⁾	d	D _h	E ⁽¹⁾	e	e ₁	e ₂	E _h	j	L	L ₃	m	Q	v	w	x	Z ⁽¹⁾
mm	17.0 15.5	4.6 4.2	0.75 0.60	0.48 0.38	24.0 23.6	20.0 19.6	10	12.2 11.8	3.4	1.7	5.08	6	3.4 3.1	12.4 11.0	2.4 1.6	4.3	2.1 1.8	0.8	0.25	0.03	2.00 1.45

Note

1. Plastic or metal protrusions of 0.25 mm maximum per side are not included.

OUTLINE VERSION	REFERENCES				EUROPEAN PROJECTION	ISSUE DATE
	IEC	JEDEC	EIAJ			
SOT141-6						92-11-17 95-03-11

Multiple voltage regulators with external reset delay and switch

TDA3604Q; TDA3604TH

HSOP20: plastic heat-dissipating small outline package; 20 leads; low stand-off

SOT418-2

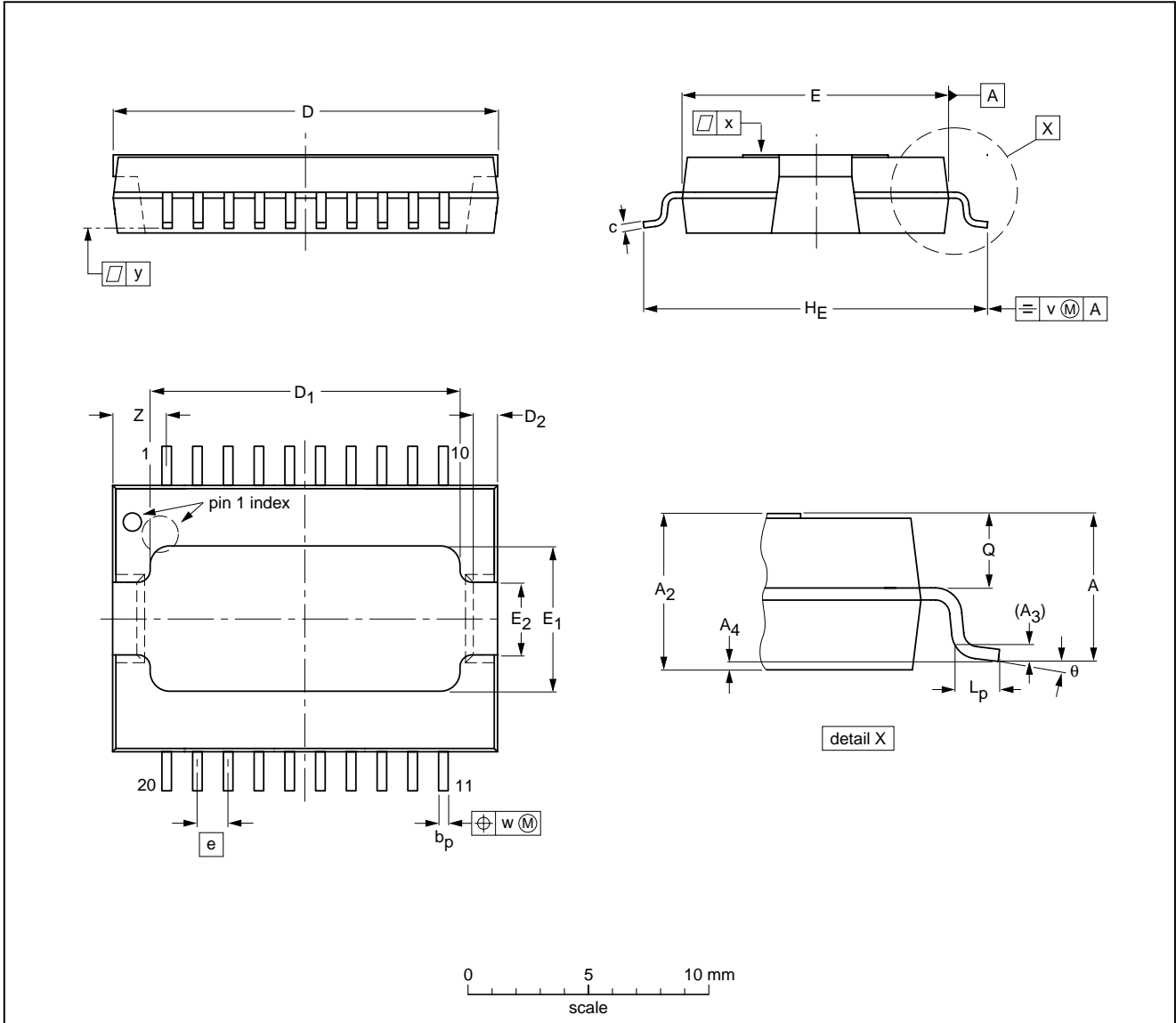

DIMENSIONS (mm are the original dimensions)

UNIT	A max.	A ₂	A ₃	A ₄	b _p	c	D ⁽¹⁾	D ₁	D ₂	E ⁽¹⁾	E ₁	E ₂	e	H _E	L _p	Q	v	w	x	y	Z	θ
mm	3.4	3.4 3.1	0.35	+0.13 -0.04	0.53 0.40	0.32 0.23	16.0 15.8	13.0 12.6	1.1 0.9	11.1 10.9	6.2 5.8	2.9 2.5	1.27	14.5 13.9	1.1 0.8	1.7 1.5	0.25	0.25	0.03	0.07	2.5 2.0	8° 0°

Note

1. Plastic or metal protrusions of 0.25 mm maximum per side are not included.

OUTLINE VERSION	REFERENCES			EUROPEAN PROJECTION	ISSUE DATE
	IEC	JEDEC	EIAJ		
SOT418-2					96-11-18

Multiple voltage regulators with external reset delay and switch

TDA3604Q; TDA3604TH

SOLDERING

Introduction

There is no soldering method that is ideal for all IC packages. Wave soldering is often preferred when through-hole and surface mounted components are mixed on one printed-circuit board. However, wave soldering is not always suitable for surface mounted ICs, or for printed-circuits with high population densities. In these situations reflow soldering is often used.

This text gives a very brief insight to a complex technology. A more in-depth account of soldering ICs can be found in our "IC Package Databook" (order code 9398 652 90011).

DBS

SOLDERING BY DIPPING OR BY WAVE

The maximum permissible temperature of the solder is 260 °C; solder at this temperature must not be in contact with the joint for more than 5 seconds. The total contact

time of successive solder waves must not exceed 5 seconds.

The device may be mounted up to the seating plane, but the temperature of the plastic body must not exceed the specified maximum storage temperature ($T_{stg\ max}$). If the printed-circuit board has been pre-heated, forced cooling may be necessary immediately after soldering to keep the temperature within the permissible limit.

REPAIRING SOLDERED JOINTS

Apply a low voltage soldering iron (less than 24 V) to the lead(s) of the package, below the seating plane or not more than 2 mm above it. If the temperature of the soldering iron bit is less than 300 °C it may remain in contact for up to 10 seconds. If the bit temperature is between 300 and 400 °C, contact may be up to 5 seconds.

HSOP

No information available at the moment.

DEFINITIONS

Data sheet status	
Objective specification	This data sheet contains target or goal specifications for product development.
Preliminary specification	This data sheet contains preliminary data; supplementary data may be published later.
Product specification	This data sheet contains final product specifications.
Limiting values	
Limiting values given are in accordance with the Absolute Maximum Rating System (IEC 134). Stress above one or more of the limiting values may cause permanent damage to the device. These are stress ratings only and operation of the device at these or at any other conditions above those given in the Characteristics sections of the specification is not implied. Exposure to limiting values for extended periods may affect device reliability.	
Application information	
Where application information is given, it is advisory and does not form part of the specification.	

LIFE SUPPORT APPLICATIONS

These products are not designed for use in life support appliances, devices, or systems where malfunction of these products can reasonably be expected to result in personal injury. Philips customers using or selling these products for use in such applications do so at their own risk and agree to fully indemnify Philips for any damages resulting from such improper use or sale.

Multiple voltage regulators with external
reset delay and switch

TDA3604Q; TDA3604TH

NOTES

Multiple voltage regulators with external
reset delay and switch

TDA3604Q; TDA3604TH

NOTES

Philips Semiconductors – a worldwide company

Argentina: see South America

Australia: 34 Waterloo Road, NORTH RYDE, NSW 2113,
Tel. +61 2 9805 4455, Fax. +61 2 9805 4466

Austria: Computerstr. 6, A-1101 WIEN, P.O. Box 213, Tel. +43 160 1010,
Fax. +43 160 101 1210

Belarus: Hotel Minsk Business Center, Bld. 3, r. 1211, Volodarski Str. 6,
220050 MINSK, Tel. +375 172 200 733, Fax. +375 172 200 773

Belgium: see The Netherlands

Brazil: see South America

Bulgaria: Philips Bulgaria Ltd., Energoproject, 15th floor,
51 James Bourchier Blvd., 1407 SOFIA,
Tel. +359 2 689 211, Fax. +359 2 689 102

Canada: PHILIPS SEMICONDUCTORS/COMPONENTS,
Tel. +1 800 234 7381

China/Hong Kong: 501 Hong Kong Industrial Technology Centre,
72 Tat Chee Avenue, Kowloon Tong, HONG KONG,
Tel. +852 2319 7888, Fax. +852 2319 7700

Colombia: see South America

Czech Republic: see Austria

Denmark: Prags Boulevard 80, PB 1919, DK-2300 COPENHAGEN S,
Tel. +45 32 88 2636, Fax. +45 31 57 0044

Finland: Sinikalliontie 3, FIN-02630 ESPOO,
Tel. +358 9 615800, Fax. +358 9 61580920

France: 4 Rue du Port-aux-Vins, BP317, 92156 SURESNES Cedex,
Tel. +33 1 40 99 6161, Fax. +33 1 40 99 6427

Germany: Hammerbrookstraße 69, D-20097 HAMBURG,
Tel. +49 40 23 53 60, Fax. +49 40 23 536 300

Greece: No. 15, 25th March Street, GR 17778 TAVROS/ATHENS,
Tel. +30 1 4894 339/239, Fax. +30 1 4814 240

Hungary: see Austria

India: Philips INDIA Ltd, Band Box Building, 2nd floor,
254-D, Dr. Annie Besant Road, Worli, MUMBAI 400 025,
Tel. +91 22 493 8541, Fax. +91 22 493 0966

Indonesia: see Singapore

Ireland: Newstead, Clonskeagh, DUBLIN 14,
Tel. +353 1 7640 000, Fax. +353 1 7640 200

Israel: RAPAC Electronics, 7 Kehilat Saloniki St, PO Box 18053,
TEL AVIV 61180, Tel. +972 3 645 0444, Fax. +972 3 649 1007

Italy: PHILIPS SEMICONDUCTORS, Piazza IV Novembre 3,
20124 MILANO, Tel. +39 2 6752 2531, Fax. +39 2 6752 2557

Japan: Philips Bldg 13-37, Kohnan 2-chome, Minato-ku, TOKYO 108,
Tel. +81 3 3740 5130, Fax. +81 3 3740 5077

Korea: Philips House, 260-199 Itaewon-dong, Yongsan-ku, SEOUL,
Tel. +82 2 709 1412, Fax. +82 2 709 1415

Malaysia: No. 76 Jalan Universiti, 46200 PETALING JAYA, SELANGOR,
Tel. +60 3 750 5214, Fax. +60 3 757 4880

Mexico: 5900 Gateway East, Suite 200, EL PASO, TEXAS 79905,
Tel. +9-5 800 234 7381

Middle East: see Italy

Netherlands: Postbus 90050, 5600 PB EINDHOVEN, Bldg. VB,
Tel. +31 40 27 82785, Fax. +31 40 27 88399

New Zealand: 2 Wagener Place, C.P.O. Box 1041, AUCKLAND,
Tel. +64 9 849 4160, Fax. +64 9 849 7811

Norway: Box 1, Manglerud 0612, OSLO,
Tel. +47 22 74 8000, Fax. +47 22 74 8341

Philippines: Philips Semiconductors Philippines Inc.,
106 Valero St. Salcedo Village, P.O. Box 2108 MCC, MAKATI,
Metro MANILA, Tel. +63 2 816 6380, Fax. +63 2 817 3474

Poland: Ul. Lukiska 10, PL 04-123 WARSZAWA,
Tel. +48 22 612 2831, Fax. +48 22 612 2327

Portugal: see Spain

Romania: see Italy

Russia: Philips Russia, Ul. Usatcheva 35A, 119048 MOSCOW,
Tel. +7 095 755 6918, Fax. +7 095 755 6919

Singapore: Lorong 1, Toa Payoh, SINGAPORE 1231,
Tel. +65 350 2538, Fax. +65 251 6500

Slovakia: see Austria

Slovenia: see Italy

South Africa: S.A. PHILIPS Pty Ltd., 195-215 Main Road Martindale,
2092 JOHANNESBURG, P.O. Box 7430 Johannesburg 2000,
Tel. +27 11 470 5911, Fax. +27 11 470 5494

South America: Rua do Rocio 220, 5th floor, Suite 51,
04552-903 São Paulo, SÃO PAULO - SP, Brazil,
Tel. +55 11 821 2333, Fax. +55 11 829 1849

Spain: Balmes 22, 08007 BARCELONA,
Tel. +34 3 301 6312, Fax. +34 3 301 4107

Sweden: Kottbygatan 7, Akalla, S-16485 STOCKHOLM,
Tel. +46 8 632 2000, Fax. +46 8 632 2745

Switzerland: Allmendstrasse 140, CH-8027 ZÜRICH,
Tel. +41 1 488 2686, Fax. +41 1 481 7730

Taiwan: Philips Semiconductors, 6F, No. 96, Chien Kuo N. Rd., Sec. 1,
TAIPEI, Taiwan Tel. +886 2 2134 2865, Fax. +886 2 2134 2874

Thailand: PHILIPS ELECTRONICS (THAILAND) Ltd.,
209/2 Sanpavuth-Bangna Road Prakanong, BANGKOK 10260,
Tel. +66 2 745 4090, Fax. +66 2 398 0793

Turkey: Talatpasa Cad. No. 5, 80640 GÜLTEPE/ISTANBUL,
Tel. +90 212 279 2770, Fax. +90 212 282 6707

Ukraine: PHILIPS UKRAINE, 4 Patrice Lumumba str., Building B, Floor 7,
252042 KIEV, Tel. +380 44 264 2776, Fax. +380 44 268 0461

United Kingdom: Philips Semiconductors Ltd., 276 Bath Road, Hayes,
MIDDLESEX UB3 5BX, Tel. +44 181 730 5000, Fax. +44 181 754 8421

United States: 811 East Arques Avenue, SUNNYVALE, CA 94088-3409,
Tel. +1 800 234 7381

Uruguay: see South America

Vietnam: see Singapore

Yugoslavia: PHILIPS, Trg N. Pasica 5/v, 11000 BEOGRAD,
Tel. +381 11 625 344, Fax. +381 11 635 777

For all other countries apply to: Philips Semiconductors, Marketing & Sales Communications,
Building BE-p, P.O. Box 218, 5600 MD EINDHOVEN, The Netherlands, Fax. +31 40 27 24825

Internet: <http://www.semiconductors.philips.com>

© Philips Electronics N.V. 1997

SCA55

All rights are reserved. Reproduction in whole or in part is prohibited without the prior written consent of the copyright owner.

The information presented in this document does not form part of any quotation or contract, is believed to be accurate and reliable and may be changed without notice. No liability will be accepted by the publisher for any consequence of its use. Publication thereof does not convey nor imply any license under patent- or other industrial or intellectual property rights.

Printed in The Netherlands

547027/1200/04/pp20

Date of release: 1997 Aug 21

Document order number: 9397 750 02741

Let's make things better.

Philips
Semiconductors



PHILIPS