

APPROVAL SHEET

Customer Name : TPV
O2 Part Number : ta9687GN
Revision : A
Description : LCDM Inverter Controller
Package Type : 16 SOP Lead-Free
Pack Type : Tube
Quantity per Type : 48
Quantity per Inner Box : 4,800
Quantity per Ship Box : 28,800

APPROVED BY:

Print Name and Signature

Date

*** Please fax back a signed copy to O₂ Micro attn: Angela Chang at (03) 564-4273 ***
***THANK YOU ***



Tel : (02) 2545-9095 ■ Fax : (02) 2545-9583
(03) 578-7448 ■ (03) 578-7897
11F., No. 54, Sec. 4, Min-Sheng E. Rd., Taipei City 105, Taiwan.
5F, No.36, Lane162, Keshiueyuan Road, Hsin Chu, Taiwan, 300

APPSHT080131-AC-DS-0.5 01/31/2008
Recipient#115828

LCDM Inverter Controller

FEATURES

- Constant operating frequency
- Drives positive/negative-impedance lamps during ignition
- High drive current for external MOSFETs
- User-defined ignition time and shutdown delay time
- Built-in intelligence for ignition and normal operation of CCFLs
- Built-in open-lamp protection and over-voltage protection for backlight system
- Optimized soft-start function

ORDERING INFORMATION

Part Number	Temp Range	Package
ta9687GN	-20°C to +85°C Note(3), page 3	16-pin SOP Lead-Free

GENERAL DESCRIPTION

ta9687 is a high performance, cost-effective CCFL (Cold Cathode Fluorescent Lamp) controller designed for driving large-size Liquid Crystal Display (LCD) applications requiring 2 to 6 CCFLs.

The controller converts unregulated DC voltages into a nearly sinusoidal lamp voltage and current waveforms.

The ta9687 supports full-bridge power conversion topologies while maintaining high-efficiency operation. The controller provides a soft-start operation, current and voltage regulation, over-voltage and over-current protection, high drive capability.

The control logic provides a regulated ignition voltage and appropriate protection features for over-voltage or over-current conditions.

The ta9687 offers a high level of integration, while maintaining flexibility and high-efficiency operation that reduces external component heating, resulting in higher reliability and longer CCFL life. The proprietary design technique provides a simple, low-cost system solution.

PIN DIAGRAM

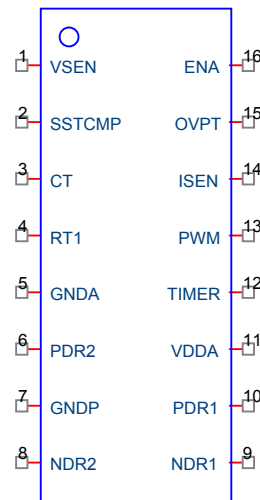

SIMPLIFIED APPLICATION CIRCUIT

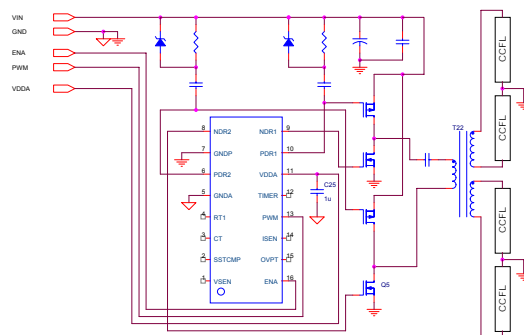

Recipient #118203 printed on 4/15/2008. This is a ONE-TIME copy. Updates will not be provided.

PIN DESCRIPTION

Pin No.	I/O ¹	Names	Description
1	I	VSEN	Voltage Sense Feedback
2	I/O	SSTCMP	Capacitor for Soft-Start and Loop Compensation
3	I/O	CT	Timing Resistor and Capacitor for Operation and Striking Frequency
4	I/O	RT1	Timing Resistor for Striking Frequency
5	---	GNDA	Signal Ground
6	O	PDR2	High Side Driver Output 2
7	---	GNDP	Power Ground
8	O	NDR2	Low Side Driver Output 2
9	O	NDR1	Low Side Driver Output 1
10	O	PDR1	High Side Driver Output 1
11	---	VDDA	Input Power Pin
12	I/O	TIMER	Timing Capacitor for Delay Timer
13	I	PWM	External PWM Dimming Input
14	I	ISEN	Current Sense Feedback
15	I	OVPT	Over-Voltage Protection Threshold Voltage
16	I	ENA	IC Enable/Disable

I/O¹: I=input, O=output, I/O=input/output

ABSOLUTE MAXIMUM RATINGS⁽²⁾

Input Voltage VDDA	-0.3V to 7.0V
GNDA, GNDP	+/- 0.3V
All other pins	-0.3V to VDDA +0.3V

Operating Temperature ³	ta9687
	-20°C to 85°C

Operating Junction Temp.	125°C
Storage Temperature ³	-55°C to 150°C

RECOMMENDED OPERATING RANGE

VDDA - Input Voltage	4.5V to 5.5V	
Other pins	0V to VDDA	
f _{op} - Operating Frequency	20KHz to 150KHz	
Thermal Impedance ^{3,4}	θ_{J-A}	θ_{J-C}
16-pin SOP	73 °C/W	8 °C/W

Note ⁽²⁾: The "Absolute Maximum Ratings" are those values beyond which the safety of the device cannot be guaranteed. The device should not be operated at these limits. The "Electrical Characteristics" table defines the conditions for actual device operation. Exposure to absolute maximum rated conditions for extended periods may affect device reliability.

Note ⁽³⁾: Not to exceed the maximum junction temperature of the IC, which relates to the operating power of the IC and the thermal resistance of the IC/package as above

Note ⁽⁴⁾: Still air, low effective thermal conductivity board per JESD51-3.

ELECTRICAL CHARACTERISTICS

All specifications below are at: VDDA=5V; R_{CT} = 84.5KΩ; C_{CT} = 220pF unless otherwise noted.

Parameter	Symbol	Test Conditions	Limits			Unit
			Min	Typ	Max	
Supply Current						
Stand By	I _{dds}	ENA=0V	--	2	5	μA
Operating	I _{dd}	Capacitance at NDR1/2 & PDR1/2 = 1nF	1.6	1.9	2.2	mA
Soft Start						
Current Source	ISSTCMP		1.90	2.55	3.20	μA
Under Voltage Lockout						
Lock Out Threshold	V _{UV,TH-OFF}	VDDA 5V→0V	3.2	3.4	3.6	V
Resume Threshold	V _{UV,TH-ON}	VDDA 0V→5V	3.3	3.6	4.0	V
Reference Voltage						
ISEN Reference Voltage		ISEN=SSTCMP	1.17	1.23	1.29	V
		Temperature Coefficient		330		ppm/ °C
VSEN Reference Voltage During Striking		VSEN=SSTCMP	2.75	2.9	3.05	V
		Temperature Coefficient		340		ppm/ °C
Driver Frequency						
Striking	f _{str}	R _{RT1} = 300K	61.5	63.8	66.0	KHZ
		Temperature Coefficient		200		ppm/ °C
Normal Operation	F _{op}		48.0	49.5	51.0	kHz
		Temperature Coefficient		180		ppm/ °C
Timer and Protection						
Striking Current Source		ISEN =0V	2.2	3.0	3.8	uA
Open Lamp and Over Voltage Protection Current Source		SSTCMP > 3.3V or VSEN>OVPT	8.1	10.85	13.6	uA
Drivers						
NDR1/2 Sink	R _{ON_SRC, NDR}		2	6	10	Ω
NDR1/2 Source	R _{ON_SNK, NDR}		10	16	22	Ω
PDR1/2 Sink	R _{ON_SRC, PDR}		6	12	18	Ω
PDR1/2 Source	R _{ON_SNK, PDR}		5	9	13	Ω
Maximum Overlap ratio			95	--	--	%
BBM1&4(PDR_L+NDR_L)			100	175	250	ns
				400		ppm/C
BBM2&3(PDR_H+NDR_H)			100	175	250	ns
				800		ppm/C

Recipient #118203 printed on 4/15/2008. This is a ONE-TIME copy. Updates will not be provided.

ELECTRICAL CHARACTERISTICS (Continued)

Parameter	Symbol	Test Conditions	Limits			Unit
			Min	Typ	Max	
PWM Dimming Control						
Logic High			2.0	----	----	V
Logic Low			----	----	1.0	V
ENABLE						
Enable Logic	V_{ON}		2.0	----	----	V
Disable Logic	V_{OFF}		----	----	1.0	V

Recipient #118203 printed on 4/15/2008. This is a ONE-TIME copy. Updates will not be provided.

FUNCTIONAL BLOCK DIAGRAM

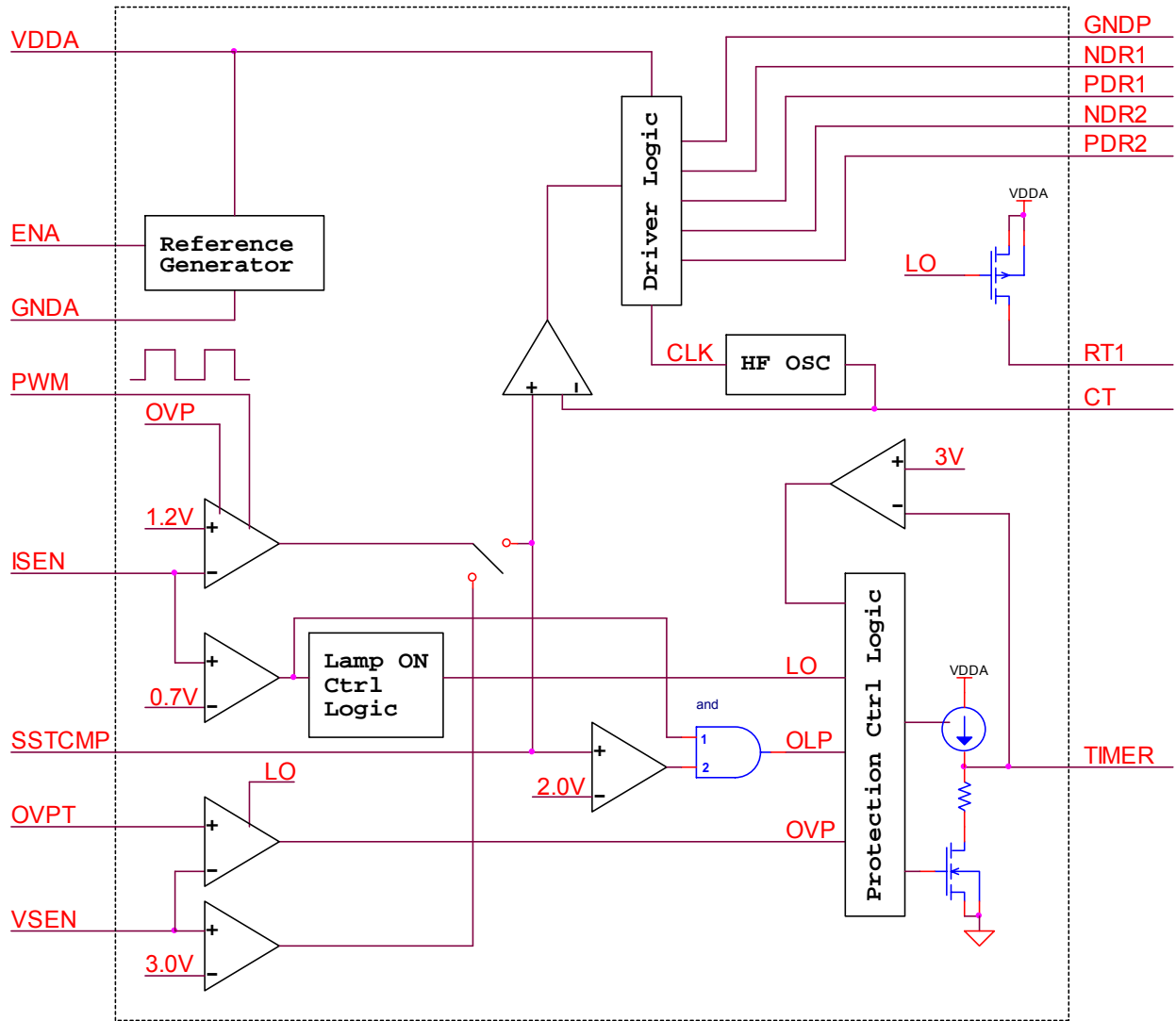

Figure 1

Recipient #118203 printed on 4/15/2008. This is a ONE-TIME copy. Updates will not be provided.

FUNCTIONAL DESCRIPTION

1. Power Conversion

The ta9687 controller supports full-bridge power conversion topology and provides symmetrical drive pulses to the tank circuit that includes the transformer(s), output capacitors and the CCFL/panel load that yields quasi-sinusoidal CCFL voltage and current waveforms. High efficiency operation of the ta9687 yields lower heat dissipation for the inverter system resulting in higher reliability.

To illustrate the controller functions, refer to Figures 1 and 2 on pages 5 and 8, respectively for the following sections.

2. Enable

Applying a voltage level greater than 2V to ENA (pin 16) enables the IC. A voltage less than 1V will disable the IC.

3. Soft-Start (SST)

Utilizing a patented multi-task technique, the soft-start function and the loop compensation function are combined to provide a good start-up characteristic. Connecting an external capacitor to SSTCMP (pin 2) provides the functions. In the start-up mode, current charges capacitor C21 connected to SSTCMP. The voltage at the capacitor controls the gradual increase in power to the transformer and subsequently to the output load. This reduces in-rush current and provides reliable operation to the CCFL.

4. Ignition

When the VDDA voltage exceeds the under-voltage lockout threshold, the IC is enabled and internal striking timer is activated.

During ignition, the striking frequency for the CCFL(s) can be chosen by the user to optimize the inverter operation.

The approximate striking frequency is calculated by the following equation.

$$F_{STRK} [KHz] = \frac{9.53 \times 10^5}{(RRT1[K\Omega] // RCT[K\Omega]) \times C_{CT} [pF]}$$

5. Aged CCFL Ignition

ta9687 provides a striking timer function to ensure that any aged, slow-turn-on CCFL is provided with sufficient voltage and time to ignite.

The transformer output voltage is sensed at VSEN (Pin 1). When the voltage at VSEN reaches a threshold of approximately 3.0V, the IC regulates the output voltage at the transformer secondary. If the lamps are not ignited when the voltage at TIMER (pin 12) reaches a threshold of approximately 3V, the IC will shutdown and latch

The approximate striking time is calculated by the following equation.

$$T_{STRK} [s] = C_{TIMER} [\mu F]$$

To resume normal operation, toggle the ENA signal or reset VDDA.

6. Normal Operation

Once the lamps are ignited and the voltage at ISEN (pin 14) is > 0.7V, the IC enters the normal operation mode and the PWM dimming control is activated.

The operating frequency is determined by resistor (R15) and capacitor (C22) connected to CT (pin 3). The control loop regulates the average current through the lamps by adjusting the overlap of the output drives. Constant frequency operation eliminates interference with the inverter and LCD panel that often occurs in a variable frequency inverter system. The peak and valley of the CT waveform are 2V and 0V respectively.

The approximate operating frequency is calculated by the following equation.

$$F_{OP} [KHz] = \frac{9.53 \times 10^5}{R_{CT} [K\Omega] \times C_{CT} [pF]}$$

7. Open Lamp Protection

If a CCFL is removed or damaged during normal operation, the voltage at SSTCMP (pin 2) rises rapidly because there is no current feedback at ISEN (pin 14). When the voltage at SSTCMP reaches a threshold of approximately 2V and ISEN is less than 0.7V, a current source charges the capacitor (C23) connected to TIMER (pin 12). Once the voltage level at the TIMER pin reaches a threshold of approximately 3V, the drive outputs shut down and latch.

The shutdown delay feature avoids inverter shutdown due to a VIN transient or if a lamp has a positive impedance characteristic.

The approximate shutdown delay time is calculated by the following equation.

$$T_{DELAY}[s] = 0.33 \times C_{TIMER}[\mu F]$$

To resume operation, toggle the ENA signal or restart VDDA.

8. Over-Voltage and Over-Current Protection

Over-voltage and over-current protection are monitored by the voltage on VSEN (pin 1). During normal operation, if a CCFL is damaged or removed, the voltage at VSEN increases. Once the voltage at VSEN exceeds the user-defined, preset voltage set by OVPT (pin 15), the driver output duty cycle is regulated and the shutdown delay timer is activated. OVPT sets the overall protection threshold voltage that is lower than ~3V (VSEN threshold). Once the voltage at TIMR pin reaches ~3V, the IC will shut down and latch. OVPT voltage setting is determined by a resistor divider (R17 and R18) connected to the OVPT.

The approximate shutdown delay time is calculated by the following equation.

$$T_{DELAY}[s] = 0.33 \times C_{TIMER}[\mu F]$$

To resume operation, toggle the ENA signal or restart VDDA.

9. Dimming Control

External PWM dimming is implemented by applying external PWM pulse to PWM (pin 13). When PWM is higher than 2V, dimming is ON and vice versa.

PACKAGE INFORMATION – 16-PIN SOP (150 mil)

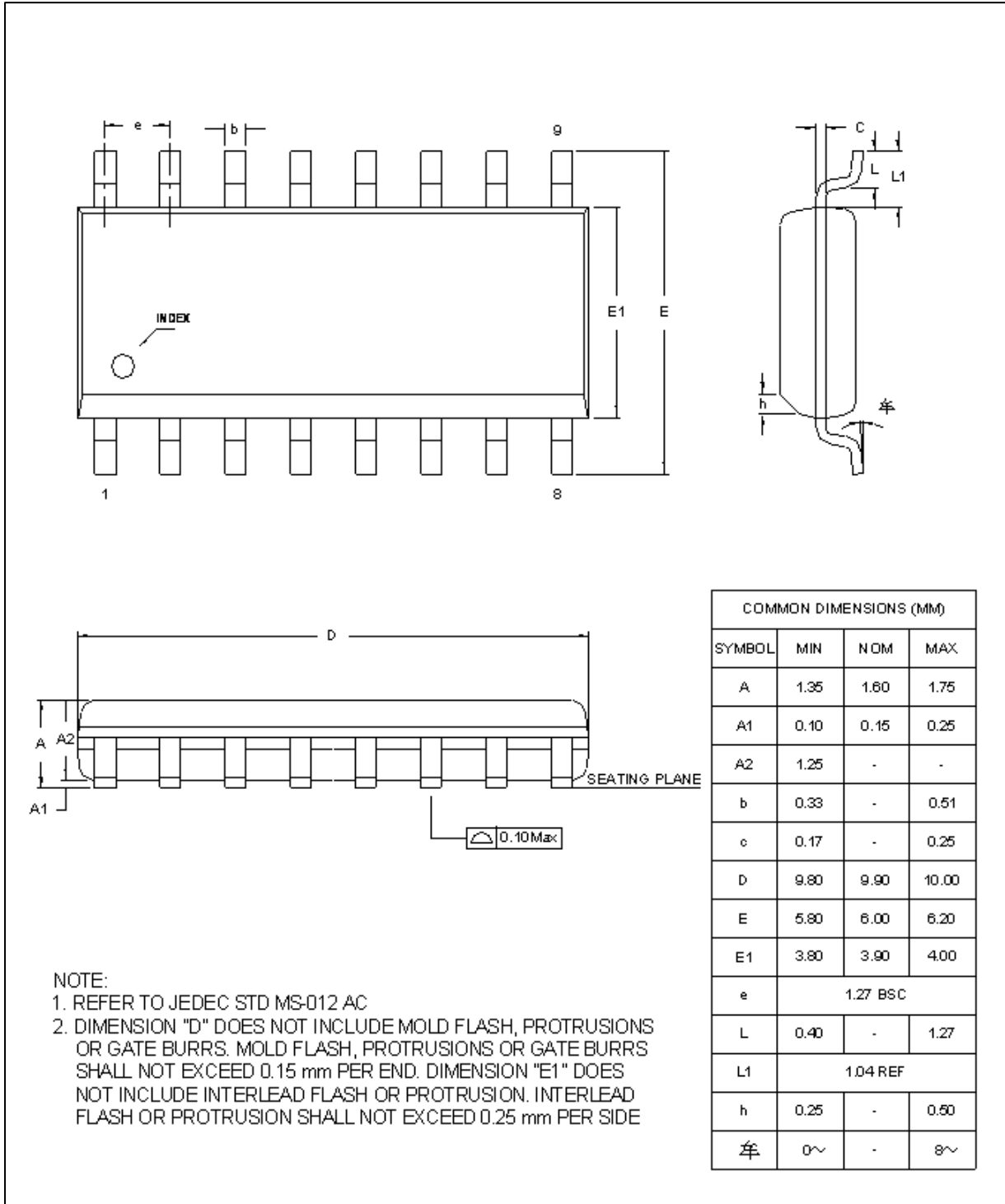

Recipient #118203 printed on 4/15/2008. This is a ONE-TIME copy. Updates will not be provided.

IMPORTANT NOTICE

No portion of O₂Micro specifications/datasheets or any of its subparts may be reproduced in any form, or by any means, without prior written permission from O₂Micro.

O₂Micro and its subsidiaries reserve the right to make changes to their datasheets and/or products or to discontinue any product or service without notice, and advise customers to obtain the latest version of relevant information to verify, before placing orders, that information being relied on is current and complete. All products are sold subject to the terms and conditions of sale supplied at the time of order acknowledgment, including those pertaining to warranty, patent infringement, and limitation of liability.

O₂Micro warrants performance of its products to the specifications applicable at the time of sale in accordance with O₂Micro's standard warranty. Testing and other quality control techniques are utilized to the extent O₂Micro deems necessary to support this warranty. Specific testing of all parameters of each device is not necessarily performed, except those mandated by government requirements.

Customer acknowledges that O₂Micro products are not designed, manufactured or intended for incorporation into any systems or products intended for use in connection with life support or other hazardous activities or environments in which the failure of the O₂Micro products could lead to death, bodily injury, or property or environmental damage ("High Risk Activities"). O₂Micro hereby disclaims all warranties, and O₂Micro will have no liability to Customer or any third party, relating to the use of O₂Micro products in connection with any High Risk Activities.

Any support, assistance, recommendation or information (collectively, "Support") that O₂Micro may provide to you (including, without limitation, regarding the design, development or debugging of your circuit board or other application) is provided "AS IS." O₂Micro does not make, and hereby disclaims, any warranties regarding any such Support, including, without limitation, any warranties of merchantability or fitness for a particular purpose, and any warranty that such Support will be accurate or error free or that your circuit board or other application will be operational or functional. O₂Micro will have no liability to you under any legal theory in connection with your use of or reliance on such Support.

COPYRIGHT © 2007-2008, O₂Micro International Limited

Recipient #118203 printed on 4/15/2008. This is a ONE-TIME copy. Updates will not be provided.

To: Top Victory Electronics (Fujian) Co.,Ltd

Date:

Company: O2Micro Electronics, Inc
 Address: 3118, Patrick Henry Drive,
 Santa Clara, CA 95054, USA
 Product name: Inverter IC

Guarantee of compliance regarding six Hazardous Substances

Top Victory Electronics (Fujian) Co.,Ltd

We (includes our subsidiary, affiliated company) here guarantee that all the components and parts shipped to you (includes directly shipping or via third parties) are in accordance with below limitation.

Hazardous substance	limitation
1. Cadmium and cadmium compounds	5ppm
2. Lead and lead compounds	100ppm
	(For solder bar;1000ppm)
3. Mercury and mercury compounds	1000ppm
4. Hexavalent chromium compounds	1000ppm
5. Polybrominated biphenyls (PBB)	1000ppm
6. Polubrominated diphenylethers (PBDE)	1000ppm
7. Cd+Pb+Hg+Cr ⁺⁶	100ppm
	(Only for packing material together with TPV production to market.)

Note:

- Please refer to file named "specification and explanation relating with hazardous substance of TPV.PPT" for exemption items from the requirements of applications of lead, mercury, cadmium and hexavalent chromium.
- In witness where of the above Guarantee has been duly exercised by the company's fully authorized representative signed below.

Signature: Wayne Anderson

Name: Wayne Anderson

Position: Quality Director

*Need to affix the official seal, afford by the post or fax.

ATTN: Sophia C.C. Akila Tsai

From: HS-Shawn

RoHS 零件 可焊性 / 耐焊接熱 標準

一 DIP 零件 , Wave Solder 要求

可焊性規格 : 條件: 溫度 255 -5/+0 °C 時間 2.5±0.5 sec

判定: 引腳沾錫面積 90% 以上

詳細參數見附件 | RoHS 零件可焊性標準 |

耐焊接熱規格 : 條件: 溫度 270 -0/+2 °C 時間 10±0.5 sec [端子]

條件: 溫度 270 -0/+2 °C 時間 20±0.5 sec [本體]

判定: 機械特性 電器特性符合規格定義要求

詳細參數見附件 | RoHS 零件耐焊接熱標準 |

二 SMD 零件 , Solder Reflow 要求

可焊性規格 : 條件: 溫度 255 -5/+0 °C 時間 2.5±0.5 sec

判定: 引腳沾錫面積 90% 以上

詳細參數見附件 | RoHS 零件可焊性標準 |

耐焊接熱規格 : 條件: 溫度 265 -0/+5 °C 時間 10 -0/+5 sec

判定: 機械特性 電器特性符合規格定義要求

詳細參數見附件 | RoHS 零件耐焊接熱標準 |

← 此部分 >250°C only

參考附件

一 RoHS 零件可焊性標準

二 RoHS 零件耐焊接熱標準

此份規格 納入各 RoHS 零件承認書內

供應商名稱 O-Micro Electronics Inc.

負責人 QA Director / Wayne Anderson

蓋章 Wayne Anderson

2002

To: TPV Electronics (Fujian) Co.,Ltd

Date:

Company: O2Micro Electronics, Inc.

Address: 3118, Patrick Henry Drive,

Santa Clara, CA 95054, USA

Guarantee of non-use of The Controlled Substances

TPV Electronics (Fujian) Co.,Ltd

We (includes our subsidiary, affiliated company) here guarantee that all the components and parts (includes parts itself and all the packages) shipped to you (includes directly shipping or via third parties) are contained free of those prohibited materials which listed on SONY standard (SS-00259) or its latest version.

1. Cadmium and cadmium compounds
2. Lead and lead compounds
3. Mercury and mercury compounds
4. Hexavalent chromium compounds
5. Polychlorinated biphenyls (PCB)
6. Polychlorinated naphthalenes (PCN)
7. Chlorinated paraffins (CP)
8. Polyvinyl chloride (PVC) and PVC compounds
9. Other chlorinated organic compounds
10. Polybrominated biphenyls (PBB)
11. Polubrominated diphenylethers (PBDE)
12. Other brominated organic compounds
13. Organic tin compounds (Tributyl tin compounds, Triphenyl tin compounds)
14. Asbestos
15. Azo compounds
16. Formaldehyde

Note: In witness where of the above Guarantee has been duly exercised by the company's fully authorized representative signed below.

Signature: Wayne Anderson

Name: Wayne Anderson

Position: Quality Director