

TOSHIBA INTEGRATED CIRCUIT

TECHNICAL DATA

TENTATIVE DATA

TA8718N
TOSHIBA BIPOLAR LINEAR INTEGRATED CIRCUIT
SILICON MONOLITHIC

VIDEO-CHROMA-DEFLECTION SYSTEM FOR A COLOR TELEVISION (PAL).

The TA8718N combines a PAL video-chroma-deflection system in a 30-lead, shrink-type, dual-in-line plastic package.

A PAL system with using TA8718N needs minimal external parts and PCB area.

Lead-functions of the TA8718N are almost compatible with those of multi-standard video-chroma-deflection IC (TA8659AN). So, the PCB can be made so that both the TA8659AN for multi standard TV and the TA8718N for PAL only TV are able to use in a same board.

FUNCTIONS

Video Section

- . Contrast control with uni-color control
- . Brightness control
- . Internal vertical blanking
- . On-screen-display circuits (R,G,B)
- . RGB primary color outputs
- . ACL (Automatic Contrast Limiter)
- . WPS (White Peak Slicer)

Chroma Section

- . ACC circuit
- . Color control/uni-color control
- . Adjustment free APC

Deflection Section

- . Adjustment free H/V oscillator by countdown system
- . Vertical-ramp generator
- . Picture phase adjustment
- . 50Hz/60Hz Mode

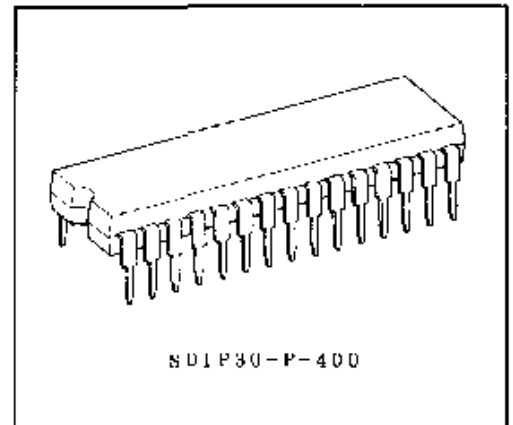

Weight: 2.2g(Typ.)

The information contained herein is presented only as a guide for the applications of our products. No responsibility is assumed by TOSHIBA for any infringements of patents or other rights of the third parties which may result from its use. No license is granted by implication or otherwise under any patent or patent rights of TOSHIBA or others.

A12(1)

TA8718N-1
1990-10-24

TOSHIBA CORPORATION

MAXIMUM RATINGS (Ta=25°C)

CHARACTERISTIC	SYMBOL	RATING	UNIT
Power Supply Voltage	VCC	15	V
Power Dissipation	P _D	1600 (Note)	mW
Input Signal Amplitude	e _{in}	5	V _{pp}
Operating Temperature	T _{opr}	-10~65	°C
Storage Temperature	T _{stg}	-55~150	°C

(Note) Derated above Ta=25°C in the proportion of 12.8mW/°C as shown below.

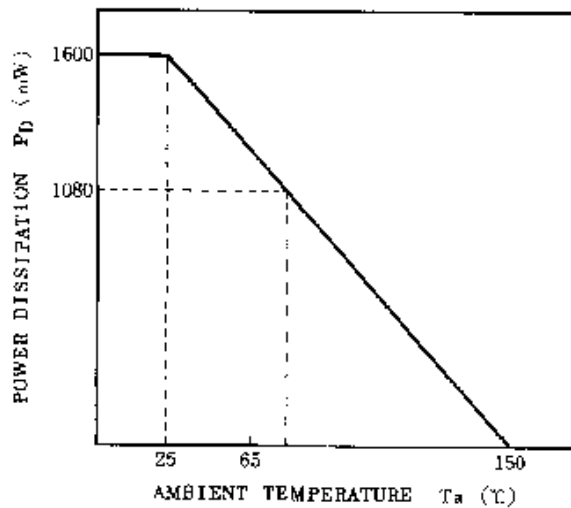

RECOMMENDED SUPPLY VOLTAGE

SUPPLY TERMINAL	SYMBOL	MIN.	TYP.	MAX.	UNIT
1	VCC	10.8	12.0	13.2	V
21	II·VCC	8.1	9.0	9.9	

BLOCK DIAGRAM

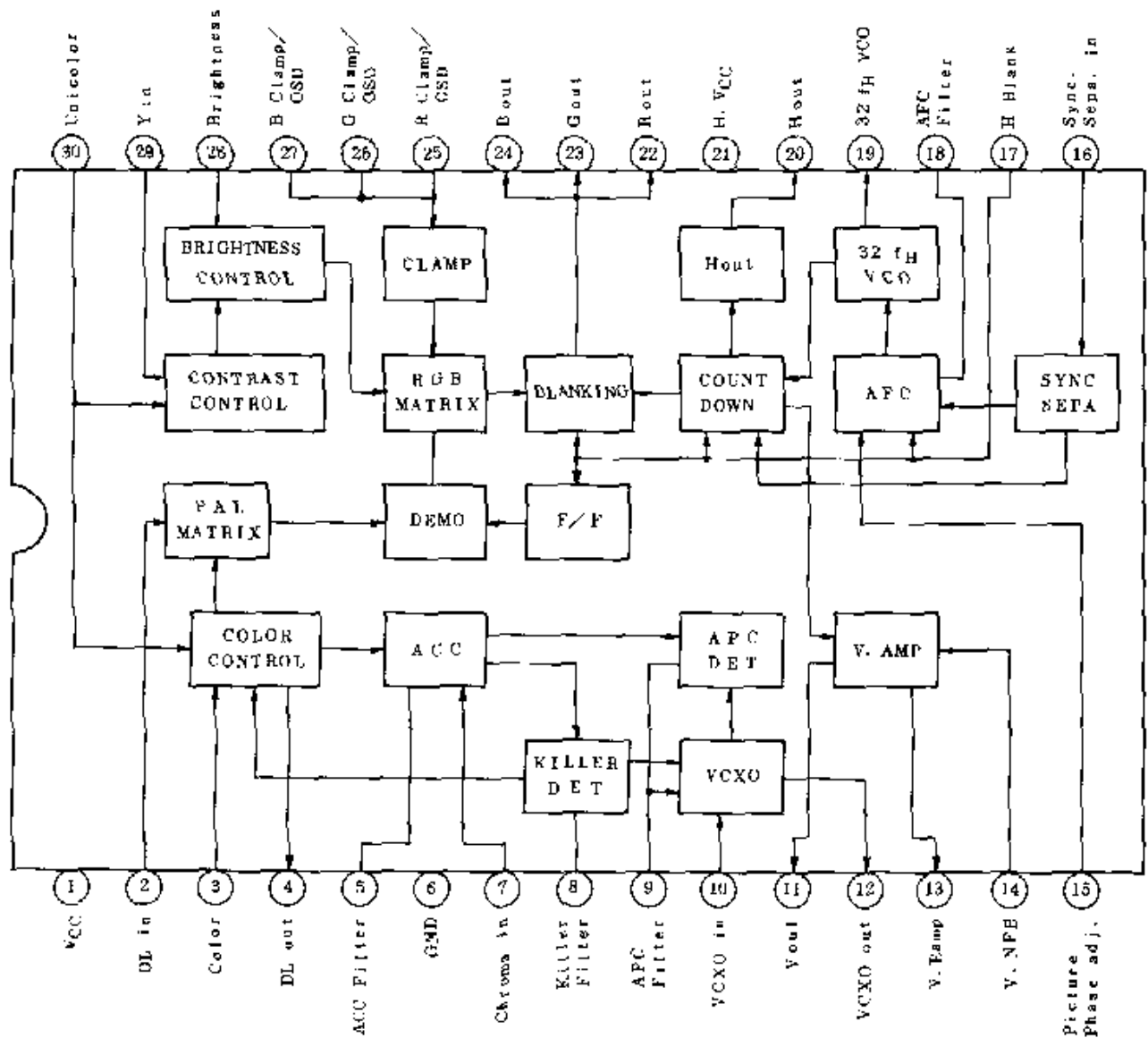

ELECTRICAL CHARACTERISTICS (Unless otherwise specified, V_{CC}=12V, H.V_{CC}=9V, T_a=25°C)

DC CHARACTERISTICS

PIN No.	TERMINAL	SYMBOL	MIN.	TYP.	MAX.	UNIT	NOTE
1	V _{CC}	V1	-	12	-	V	
2	DL in	V2	11.0	11.3	11.5		
3	Color	V3	-	-	-		
4	DL out	V4	6.2	6.4	7.2		
5	ACC Filter	V5	9.6	10.1	10.6		Terminal open
6	GND	V6	-	GND	-		
7	Chroma in	V7	3.2	3.7	4.2		No signal
8	Killer Filter	V8	5.2	5.7	6.2		No signal
9	APC Filter	V9	5.1	6.0	6.9		
10	V _{CC} O in	V10	2.8	3.3	3.8		
11	V out	V11	3.0	3.7	4.5		
12	V _{CC} O out	V12	7.8	8.8	9.9		
13	V.Ramp	V13	7.4	7.6	7.8		
14	V.NFB	V14	-	-	-		
15	Picture Phase Adj.	V15	4.1	4.5	4.9		
16	Sync. Sepa. in	V16	2.2	2.7	3.2		
17	FBP in	V17	-	-	-		
18	AFC Filter	V18	6.7	7.3	7.8		
19	32FH VCO	V19	5.3	6.0	6.3		
20	H out	V20	4.7	5.0	5.3		
21	H.V _{CC}	V21	-	9.0	-		
22	R out	V22	2.7	3.0	3.5		
23	G out	V23	2.7	3.0	3.5		#28: 3.1V
24	B out	V24	2.7	3.0	3.5		
25	R Clamp, R OSD in	V25	3.9	4.4	5.2		
26	G Clamp, G OSD in	V26	3.9	4.4	5.2		#28: 3.1V
27	B Clamp, B OSD in	V27	3.9	4.4	5.2		
28	Brightness	V28	-	-	-		
29	Y in	V29	2.8	3.1	3.5		
30	Unicolor	V30	-	-	-		

SUPPLY CURRENT

PIN No. : #

ITEM	SYMBOL	MIN.	TYP.	MAX.	UNIT
V _{CC}	I _{CC}	31.9	46.8	69.0	mA
H.V _{CC}	I _{CC} H	6.7	11.1	16.7	

TA8718N-4

1990-10-24

TOSHIBA CORPORATION

AC CHARACTERISTICS

VIDEO STAGE

CHARACTERISTIC	SYMBOL	TEST CONDITION	MIN.	TYP.	MAX.	UNIT
Video Input Impedance	Z _{in29}	Note 1	7.5	10	12.5	kΩ
Video Input Dynamic Range	V _{Yi}	Note 2	3.2	3.7	-	V _{p-p}
Linearity (lower side)	V _{dol}	Note 3	0.1	0.4	0.7	V
Linearity (higher side)	V _{doh}	Note 4	7.7	8.1	8.5	V
Video Gain	G _Y	Note 5	6.1	8.0	9.2	Times
Video Frequency Band Width	G _f	Note 6	1	0	-3	dB
Uni-Color Control DC Voltage Range	ΔV _{UY}	Note 7	1.0	1.5	2.0	V
Uni-Color Control Ratio	ΔG _Y	Note 8	19	20	21	dB
Uni-Color Center Voltage	V _{UYC}	Note 9	3.1	3.4	3.7	V
Brightness Control Sensitivity	G _{BR}	Note 10	0.9	1.0	1.1	Times
Brightness Control Center Voltage	V _{#28}	Note 11	2.8	3.1	3.4	V
ACL Sink Current	I _{ACL}	Note 12	1.0	1.5	2.0	mA
ACL Starting Level	V _{PL}	Note 13	7.3	7.5	7.7	V
White Peak Slice Level	V _{PS}	Note 14	7.9	8.1	8.3	V
V-BLK Output Level	V _{VR}	Note 15	1.0	1.5	2.0	V
	V _{VG}					
	V _{VB}					
H-BLK Output Level	V _{HR}	Note 16	1.0	1.5	2.0	V
	V _{HG}					
	V _{HB}					
DC Restoration Ratio	I _{DC}	Note 17	95	98	100	%
Output Sink Current	I _{out}	Note 18	1.4	2.0	2.6	mA
Video Mute SW Threshold Level	V _{#28M}	Note 19	0.2	0.4	0.7	V
Video Mute Output Level	V _{#22M}	Note 20	3.0	3.2	3.4	V
	V _{#23M}					
	V _{#24M}					
Service Output Level	V _{#22S}	Note 21	3.0	3.2	3.4	V
	V _{#23S}					
	V _{#24S}					
Clamp Terminal Voltage	V _{clmp}	Note 22	3.9	4.4	4.9	V

TA8718N-5
1990-10-24

TOSHIBA CORPORATION

CHARACTERISTIC	SYMBOL	TEST CONDITION	MIN.	TYP.	MAX.	UNIT
OSD Threshold (H)	V _{OHON}	Note 23	6.1	6.6	7.1	V
OSD Threshold (L)	V _{OION}		6.1	6.6	7.1	V
OSD Output Level (H)	V _{OSDH}		7.3	7.5	7.7	V
OSD Output Level (L)	V _{OSDL}		2.2	2.5	2.8	V
OSD Output H Level Rise Time	t _{RHi}	Note 24	-	10	100	nsec
OSD Output H Level Fall Time	t _{FHi}		-	30	100	
OSD Output L Level Fall Time	t _{FLo}		-	25	100	
OSD Output L Level Rise Time	t _{FLo}		-	15	100	
OSD Output H Level Rise Delay Time	t _{PRHi}		-	0	±45	
OSD Output H Level Fall Delay Time	t _{PFHi}		-	45	100	
OSD Output L Level Fall Delay Time	t _{PRLo}		-	35	100	
OSD Output L Level Rise Delay Time	t _{PFLo}		-	25	100	
Blanking Pulse ON Level	V _{BPON}	Note 25	0.75	1.25	1.75	V
Blanking Pulse Delay Time	t _{BPON}	Note 26	-	0.35	0.5	μsec
	t _{BPOF}		-	0.7	0.9	

CHROMA STAGE

CHARACTERISTIC	SYMBOL	TEST CONDITION	MIN.	TYP.	MAX.	UNIT	
Delay Line Drive Chroma Level	V _{4C1}	Note 27	0.85	1.2	1.7	Vp-p	
	V _{4C2}		1.7	2.4	3.4		
ACC Characteristic	e _a	Note 28	0.2	0.5	-	Vp-p	
	A		0.9	1.0	1.3		Times
Delay Line Amp. Characteristic	V _{2C}	Note 29	0.11	0.16	0.25	mVp-p	
	V _{4C}		0.85	1.2	1.7		Vp-p
	GDL		14	17.5	21		
50Hz/60Hz Switching Threshold	V _{2 60}	Note 30	8.5	9.5	10.5	V	
Color Control Characteristic	V ₃	Note 31	2.7	3.1	3.5	V	
	ΔV ₃		0.6	1.3	1.9		

TA8718N-6

1990-10-24

TOSHIBA CORPORATION

CHARACTERISTIC	SYMBOL	TEST CONDITION	MIN.	TYP.	MAX.	UNIT
Uni-Color Control Characteristic	e_U	Note 32	18	20	22	dB
	V30		2.7	3.1	3.5	V
	$\Delta V30$		0.6	1.3	1.9	
Killer Threshold	e_{hCol}	Note 33	0.6	2.5	4.3	mVp-p
	$e_{hB/W}$		0.6	1.0	1.7	
Killer Ident Threshold	$V_{8B/W}$	Note 34	-	6.0	-	V
	V_{8S}		-	6.4	-	
	V_{8C}		-	6.4	-	
	$\Delta V8$		0.2	0.4	-	
APC Pull-in/Hold Range	f12P	Note 35	± 250	± 500	± 1000	Hz
	f12H		± 250	± 500	± 1000	
Subcarrier Frequency Control Sensitivity	β	Note 36	1.5	2.75	4.0	Hz/mV
APC Sweeping Period-1	Sv1	Note 37	6.3	6.7	7.1	V
	Sv2		5.3	5.7	6.0	
	Sv3		0.7	1.0	1.3	
APC Sweeping Period-2	t1	Note 38	4	12	20	msec
	t2		35	70	115	
	t3		39	82	135	
Color Differential Signal Output Level	v_{22R}	Note 39	2.4	3.5	5.0	Vp-p
	v_{23G}		1.5	2.1	3.1	
	v_{24B}		4.4	6.3	8.9	
Relative Ratio	$v_{R/B}$	Note 40	0.43	0.56	0.69	Times
	$v_{G/B}$		0.27	0.34	0.41	
Relative Phase	θ_{R-B}	Note 40	80	90	95	deg
	θ_{G-B}		221	236	246	
Residual Carrier	v_{RSC}	Note 41	-	-	30	mVp-p
	v_{GSC}		-	-	20	
	v_{BSC}		-	-	50	
Output Harmonics	v_{RHC}	Note 42	-	-	100	mVp-p
	v_{GHC}		-	-	50	
	v_{BHC}		-	-	100	

TA8718N-7

1990-10-24

TOSHIBA CORPORATION

DEFLECTION STAGE

CHARACTERISTIC	SYMBOL	TEST CONDITION	MIN.	TYP.	MAX.	UNIT
Synch. Sepa. Input Current Sensitivity	I_{IN16}	Note 43	15	25	40	μA
H.AFC Phase Detector Current	I_{DET}	Note 44	490	600	760	μA
H.AFC Masking Period	T_{CO18}	Note 45	-	309-6	-	μ
32f ₀ VCO Starting Voltage	V_{ON}	Note 46	4.4	4.6	4.8	V
H. Output Starting Voltage	V_{ON20}	Note 47	4.7	5.2	5.7	V
Horizontal Free-running Frequency	f_0	Note 48	15.475	15.625	15.775	kHz
Horizontal Frequency Control Range	f_{max}	Note 49	16.400	16.700	16.900	kHz
	f_{min}		14.700	15.000	15.200	
Horizontal Frequency Control Sensitivity	β_H	Note 50	2.2	2.5	2.8	kHz/V
H. Output Duty Cycle	T_{20}	Note 51	41	43	45	%
H. Output Level	V_{H20}	Note 52	4.7	5.0	5.3	V
	V_{L20}		-	0	100	
Horizontal Phase Adjustment Range	$\Delta G15$	Note 53	2.6	2.8	3.0	μ sec
Horizontal Phase Shift With 50/60 Switching	$G17$	Note 54	1.5	1.6	1.7	μ sec
Vertical Retrace Pulse Period	T_{r1}	Note 55	-	10	-	μ
	T_{r2}		-	10	-	
Peak Voltage of Ramp Wave	V_{H13}	Note 56	7.4	7.6	7.8	V
Ramp Output Current	I_{o13}	Note 57	-	28	-	mA
Vertical Amplifier Gain	G_V	Note 58	18	20	22	dB
Vertical Output Maximum Voltage	V_{H11}	Note 59	3.0	3.7	4.5	V
Vertical Output Minimum Voltage	V_{L11}	Note 60	-	0	0.3	V
Vertical Output Current	I_{o11}	Note 61	20	35	-	mA
Vertical Pull in Range	f_{PV1}	Note 62	-	268.5	-	μ
	f_{PV2}		-	352.5	-	
	f_{PV3}	Note 63	-	232.5	-	
	f_{PV4}		-	288.5	-	

TA8718N-8

1990-10-24

TOSHIBA CORPORATION

ELECTRICAL CHARACTERISTICS TEST CONDITION

Video Stage: Test Circuit 1

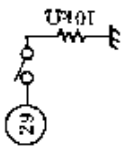
NOTE	CHARACTERISTIC	SYMBOL	TEST CONDITION				TEST METHOD	
			Unicolor	Color Bright	SW29	SW36		
1	Video Input Impedance	Z_{in29}	Min.	Min.	Center	c	a	<p>Measure DC voltage at #29.</p> <p>SW off: V#29A SW on : V#29B</p>  <p>$Z_{in} = \left(\frac{V_{\#29A}}{V_{\#29B}} - 1 \right) \times 10^4 \Omega$</p>
2	Video Input Dynamic Range	V_{yi}	Min.	Min.	Adj.	c	a	<p>(1) Adjust Brightness Control to set #24 voltage to be 3.0V during trace period.</p> <p>(2) Measure #27 voltage, and apply that voltage to #27 with external power supply.</p> <p>(3) Vary DC voltage at #29, and measure voltage at #24.</p> <p>(4) $V_{yi} = V_{r12} - V_{r11}$</p>

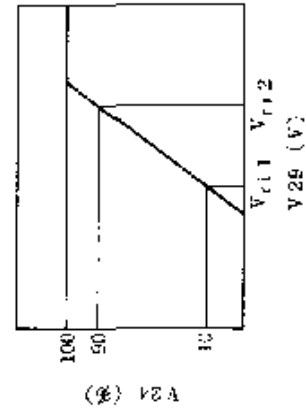

TA8718N-9

1990-10-24

TOSHIBA CORPORATION

NOTE	CHARACTERISTIC	SYMBOL	TEST CONDITION				TEST METHOD
			Unicolor	Color	Bright	SW30	
3	Linearity (Lower side)	V _{do1}					(1) Adjust Brightness Control to set #24 voltage to be 3.0V during trace period. (2) Measure #27 voltage, and apply that voltage to #27 with external power supply. (3) Apply DC 7V to #30. (4) Vary DC voltage at #29, and measure minimum and maximum voltage at #24. (5) Measure the voltage of Red and Green output in the same way as Blue.
				Min.	Adj.	c	
4	Linearity (Higher side)	V _{do2}					
5	Video Gain	GY					 (1) Adjust Brightness Control to set #24 voltage to be 3.0V during trace period. (2) Measure AC level at #24. $V_{#24}$ (3) $G_Y = \frac{V_{#24}}{0.3}$ (4) Measure the voltages of Red and Green output in the same way as Blue.
			Max.	Min.	Adj.	a	

TA8718N-10

1990-10-24

TOSHIBA CORPORATION

NOTE	CHARACTERISTIC	SYMBOL	TEST CONDITION			TEST METHOD
			Unicolor	Color	Bright	
6	Video Frequency Band width	GF	Max.	Min.	Adj.	<p> (1) Adjust Brightness Control to set #24 voltage to be 3.0V during trace period. (2) Measure AC level at #24. (3) $GF = 20 \log \frac{V_{\#24}}{100 \mu V} [dB]$ (4) Measure the voltages of Red and Green output in the same way as Blue. </p>
			Adj.	Adj.	a	
7	Uni-Color Control DC Voltage Range	ΔV_{DY}	Adj.	Min.	Adj.	<p> (1) Adjust Brightness Control to set #24 voltage to be 3.0V during trace period. (2) Vary DC voltage at #30, and Measure AC level at #24. </p> <p> </p>
			Adj.	Adj.	a	

TA8718N-11

1990-10-24

TOSHIBA CORPORATION

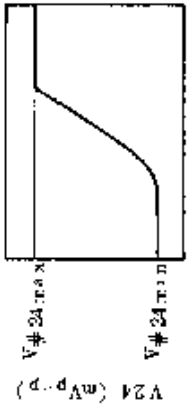
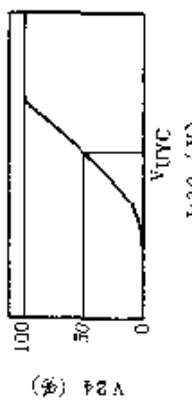
NOTE	CHARACTERISTIC	SYMBOL	TEST CONDITION				TEST METHOD
			Unicolor	Color	Bright	SM30	
8	Uni-Color Control Range	AGLY	Adj.	Min.	Adj.	a	<p>(1) The same as the Note 7.</p> <p>(2) $\Delta GLY = 20 \log(V_{\#24max}/V_{\#24min})$ [dB]</p> 
9	Uni-Color Center Voltage	VJYC	Adj.	Min.	Adj.	a	<p>The same as the Note 7.</p> 
10	Brightness Control Sensitivity	G3R	Max.	Min.	Adj.	a	<p>(1) Adjust Brightness Control to set #24 voltage to be 3.0V during trace period.</p> <p>(2) Increase voltage at #28 by +1.0V.</p> <p>(3) Measure voltage at #24 during the trace period, $V_{\#24}$.</p> <p>(4) $G3R = (V_{\#24} - 3.0) / 1.0$</p>

TA8718N-12

1990-10-24

TOSHIBA CORPORATION

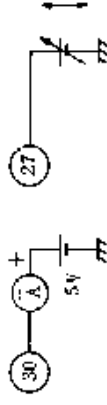
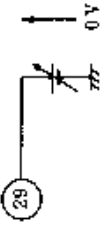
NOTE	CHARACTERISTIC	SYMBOL	TEST CONDITION				TEST METHOD
			Unicolor	Color	Bright	SW30	
11	Brightness Control Center Voltage	V#28	Max.	Min.	Adj.	a	(1) Adjust Brightness Control to set #24 voltage to be 3.0V during trace period. (2) Measure voltage at #28.
12	ACL Sink Current	IACL	5V	Min.	Adj.	b	 <p>When voltage at #24 is same as the slice level, measure input current at #30.</p>
13	ACL Starting Level	VPL	Max.	Max.	Adj.	a	 <p>(1) Adjust Brightness Control to set #24 voltage to be 3.0V during trace period. (2) Measure #27 voltage, and apply that voltage to #27 with external power supply. (3) Measure voltage at #24 during trace period when DC voltage at #30 varies.</p>

TA8718N-13
1990-10-24

TOSHIBA CORPORATION

NOTE	CHARACTERISTIC	SYMBOL	TEST CONDITION				TEST METHOD		
			Unicolor	Color	Bright	SW30			
14	White Peak Slice Level	V _{PS}	7V	Max.	Adj.	c	b	 <p>(1) Adjust Brightness Control to set V₂₄ voltage to be 3.0V during trace period.</p> <p>(2) Measure #27 voltage, and apply that voltage to #27 with external power supply.</p> <p>(3) Measure voltage at #24 during trace period it's clipped.</p>	
15	V-BLK Output Level	V _{VR} V _{VG} V _{VB}	Max.	Max.	Adj.	c	a		Measure V-BLK pulse levels of #22, #23 and #24.
16	H-BLK Output Level	V _{HR} V _{HC} V _{HB}	Max.	Max.	Adj.	c	a		Measure H-BLK pulse levels of #22, #23 and #24.

TA8718N-14

1990-10-24

TOSHIBA CORPORATION

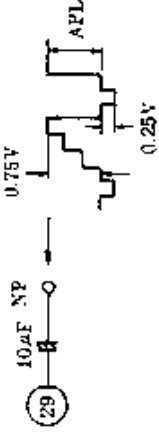
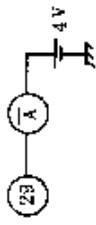
NOTE	CHARACTERISTIC	SYMBOL	TEST CONDITION			TEST METHOD
			Unicolor	Color	Bright	
17	DC Restoration Ratio	T _{DC}	Adj.	ML ₁	Adj.	 <p>(1) Adjust Brightness Control to set #24 voltage to be 3.0V during trace period when no signal inputs.</p> <p>(2) Adjust Uni-color control to set #24 AC amplitude during trace period to be 1.25Vp-p.</p> <p>(3) APL: 10%-90% Measure pedestal level change. ΔV_P</p> <p>(4) $T_{DC} = (1 - \Delta V_P) \times 100 (\%)$</p>
			ML ₁	ML ₁	Adj.	
18	Output Sink Current	I _{out}	Min.	Min.	Adj.	 <p>(1) Adjust Brightness Control to set #24 voltage to be 3.0V during trace period.</p> <p>(2) Measure input current at #24.</p> <p>(3) Measure the current of Red and Green outputs in the same way as Blue.</p>
			Adj.	Adj.	Adj.	

TA8718N-15

1990-10-24

TOSHIBA CORPORATION

NOTE	CHARACTERISTIC	SYMBOL	TEST CONDITION				TEST METHOD
			Unicolor	Color	Bright	SW30	
19	Video Mute SW Threshold Level	V#28M	Max.	Max.	Adj. c	a	 <p>(1) Adjust Brightness Control to set #24 voltage to be 3.0V during trace period. (2) Reduce the applied voltage at #28 and measure the voltage when #3 voltage varies.</p>
20	Video Mute Output Level	V#22M V#23M V#24M	Max.	Max.	GND c	a	<p>Measure voltage at #22, #23 and #24 during trace period, connecting the terminal 28 to GND (Video Mute condition).</p>
21	Service Output Level	V#22S V#23S V#24S	Max.	Max.	Adj. c	a	<p>(1) Adjust Brightness Control to set #24 voltage to be 3.0V during trace period. (2) Apply DC 9V to #11. (3) Measure voltage at #22, #23, and #24 during the period.</p>
22	Clamp Terminal Voltage	Vclamp	Max.	-	Adj. c	a	<p>(1) Adjust Brightness Control to set #24 voltage to be 3.0V during trace period. (2) Measure DC voltage at #25, #26 and #27.</p>

TA8718N-16

1990-10-24

TOSHIBA CORPORATION

NOTE	CHARACTERISTIC	SYMBOL	TEST CONDITION						TEST METHOD
			Unicolor	Bright	SW29	SW25	SW26	SW27	
	OSD Threshold (H)	V _{OHON}							(1) Adjust Brightness Control to set #22 voltage to be 5V during trace period. (2) Measure #25 DC voltage, and apply that voltage to #25 with external power supply. (3) Increase the voltage. (4) Measure voltage at #25 (V _{OHON}) and #22 (V _{OSDH}) during trace period when voltage at #22 is clamped on A.C.L. level. (5) Measure voltages at #25 (V _{OLON}) and #23 (V _{OSDL}) during trace period when voltage at #23 is clamped lower than black level. (6) Measure the voltage of #26 and #27 in the same way.
	OSD Threshold (L)	V _{OLON}							
23			Max.	Adj.	c	f	f	b	
	OSD Output (H)	V _{OSDH}							
	OSD Output (L)	V _{OSDL}							

TA8718N-17

1990-10-24

TOSHIBA CORPORATION

NOTE	CHARACTERISTIC	SYMBOL	TEST CONDITION					TEST METHOD
			Unicolor	Color	Bright	SW25	SW26	
24	OSD Output H Rise Time	t_{RH1}						(1) Adjust Brightness Control to set #22 voltage to be 5V during trace period. (2) Apply (a) signal to #25. (3) Measure t_{RH1} , t_{PRH1} , t_{FH1} and t_{PFH1} as (b) at #22. (4) Measure t_{RLo} , t_{PRLo} , t_{FLo} and t_{PFLo} as (c) at #23 or #24. (5) Measure the same periods of #23 and #24 as #22.
	OSD Output H Fall Time	t_{FH1}					a or b	
	OSD Output L Rise Time	t_{RLo}					a or b	
	OSD Output L Fall Time	t_{FLo}					a or b	
	OSD Output H Rise Delay Time	t_{PRH1}		Ma.	Adj.			
	OSD Output H Fall Delay Time	t_{PFH1}						
	OSD Output L Rise Delay Time	t_{PRLo}						
	OSD Output L Fall Delay Time	t_{PFLo}						

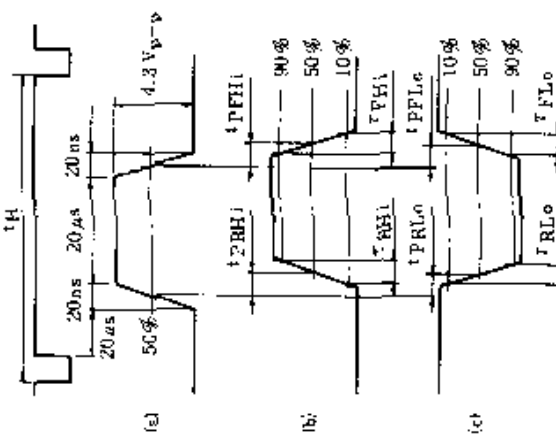

TA8718N-18

1990-10-24

TOSHIBA CORPORATION



NOTE	CHARACTERISTIC	SYMBOL	TEST CONDITION				TEST METHOD
			Unicolor	Color	Bright	SW30	
25	Blanking Pulse ON Level	VBPON				SW30	(1) Apply blanking pulses and increase the amplitude from 0Vp-p. (2) Measure the amplitude when blanking output come out at #22. (3) Measure tBPON and tBPOF as the figure.
		tBPON	Max.	3V	c	a	
26	Blanking Pulse Relay Time	tBPON	Max.				
		tBPOF					

TA8718N-19

1990-10-24

TOSHIBA CORPORATION

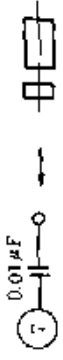
Chroma Stage: Test Circuit 2 (Adjust external components around D1 with Philips color pattern.)

NOTE	CHARACTERISTIC	SYMBOL	TEST CONDITION							TEST METHOD
			SW2	SW7a	SW7b	SW7c	SW8	SW9	Contrast	
27	Delay Line Drive Chroma Level	v _{4C1}								 <p>burst : chroma = 1 : 1, 1 : 2 burst 100mVp-p Measure AC level at #4.</p>
		v _{4C2}	OFF	a	ON	a	d	OFF	Max. Min.	
28	ACC Characteristics	ea								 <p>burst : chroma = 1 : 1 burst 10mVp-p, 100mVp-p, 300mVp-p</p>
		A	OFF	a	ON	a	d	OFF	Max. Min.	

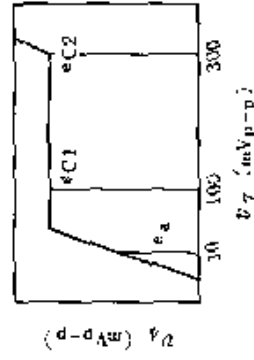

(1) Measure AC level at #4.
(2) $A = \frac{eC2}{eC1}$

TA8718N-20

1990-10-24

TOSHIBA CORPORATION

NOTE	CHARACTERISTIC	SYMBOL	TEST CONDITION						TEST METHOD
			SW2	SW7a	SW7b	SW7c	SW8	SW9	
29	Delay Line Amp. Characteristic	V _{2C}	a	a	ON	a			(1) Input "10" color bar signal of 3.58MHz/4.43MHz. (2) Measure AC levels at #2 and #4. (3) GDL=20kΩ $\frac{V_{4C}}{V_{2C}}$
		V _{4C}						Max.	
		GDL							
30	50/60Hz S ₀ Threshold	V _{2 60}	a	b	OFF	b	d		Apply DC voltage at #2 from 0V to 9V. Monitor the output pulse frequency at #13.
			b						
31	Color Control Characteristics	V ₃	OFF	a	ON	a	a		(1) Sync. sep. In, no signal FBP in (2) Vary DC voltage at #3, and measure AC level at #4.
		AV ₃						Adj.	

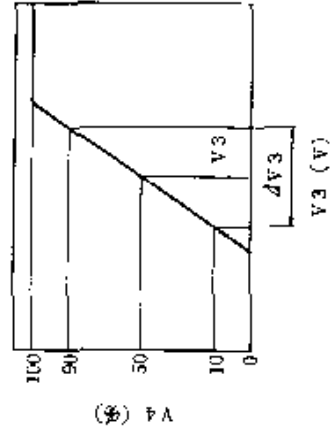
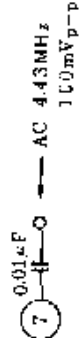
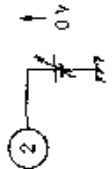

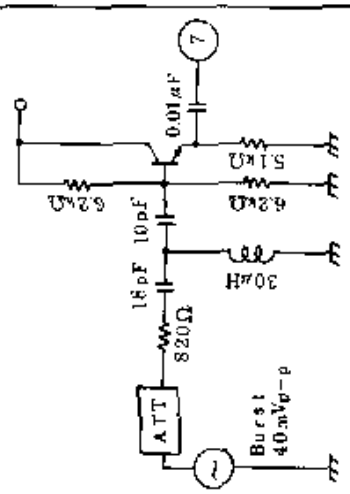
NOTE	CHARACTERISTIC	SYMBOL	TEST CONDITION							TEST METHOD	
			SW2	SW7a	SW7b	SW7c	SW8	SW9	Color		Contrast
32	Uni-Color Control Characteristics	e_u									 <p>(1) Sync. Sepa. in } no signal FBP in } (2) vary DC voltage at #30, and measure AC level at #4.</p>
		V30	OFF	a	ON	a	a	OFF	Adj.	Adj.	
		$\Delta V30$									
33	Killer Threshold	e_{bc01}									 <p>e_{bc01} : B/W → Color $e_{bb/W}$: Color → B/W</p>
		$e_{bb/W}$	OFF	a	ON	a	d	OFF	Max.	Max.	

TA8718N-22

1990-10-24

TOSHIBA CORPORATION

NOTE	CHARACTERISTIC	SYMBOL	TEST CONDITION						TEST METHOD	
			SW2	SW7a	SW7b	SW7c	SW8	SW9		Color
34	Killer Ident Threshold	V8B/W								<p>(1) Measure voltage at #8 with a high-impedance meter. V8B/W</p> <p>(2) Apply and vary voltage to #8, and measure the voltage when V8C/D sweep starts. V8S</p> <p>(3) Measure the voltage at #8 when color terminal change high.</p> <p>(4) $\Delta V8 = V8C - V8B/W$</p>
		V8S	OFF	b	OFF	b	c	OFF		
		V8C								
		$\Delta V8$								
35	Pull-in/Hold Range	f12P							<p>Composite Video Signal</p> <p>Measure pull-in and hold frequencies.</p>	
		f12H	OFF	a	ON	a	d	OFF		

TA8718N-23

1990-10-24

TOSHIBA CORPORATION

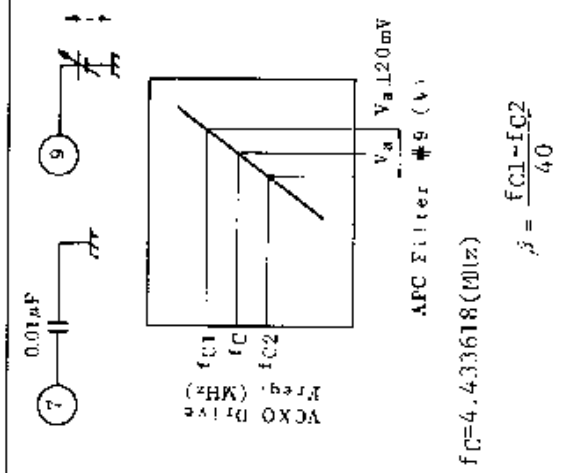
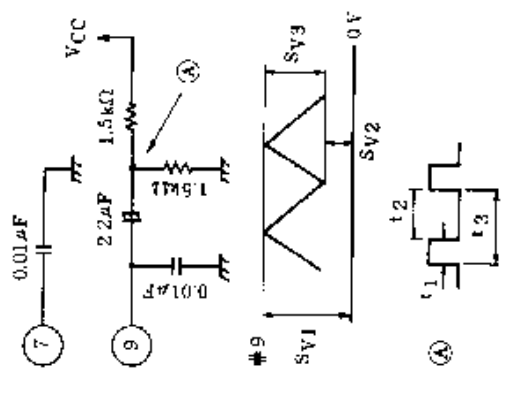
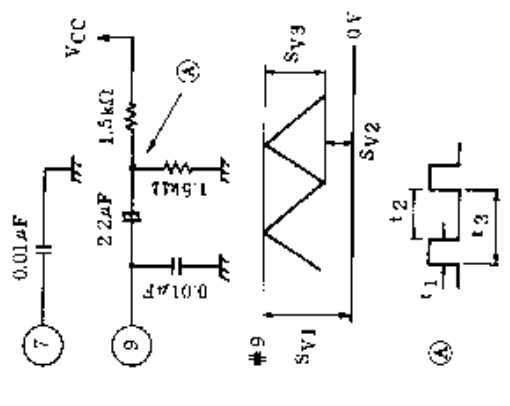
NOTE	CHARACTERISTIC	SYMBOL	TEST CONDITION						TEST METHOD
			SW2	SW7a	SW7b	SW7c	SW8	SW9	
36	Subcarrier Frequency Control Sensitivity	β	OFF	b	OFF	b	d	ON	 <p>VCO Drive Freq (MHz)</p> <p>Va (V)</p> <p>Va (120mV)</p> <p>AFC Filter #9 (V)</p> <p>$f_C = 4.433618 \text{ (MHz)}$</p> <p>$\beta = \frac{f_{C1} - f_{C2}}{40}$</p>
			OFF	b	OFF	b	d	OFF	
37	AFC Sweeping Period-1	SV1	OFF	b	OFF	b	d	OFF	 <p>VCC</p> <p>0.01µF</p> <p>2.2µF</p> <p>1.5kΩ</p> <p>71MΩ</p> <p>0.01µF</p> <p>SV3</p> <p>SV2</p> <p>0V</p> <p>t1</p> <p>t2</p> <p>t3</p>
		SV2	OFF	b	OFF	b	d	OFF	
		SV3	OFF	b	OFF	b	d	OFF	
38	AFC Sweeping Period-2	t1	OFF	b	OFF	b	d	OFF	 <p>VCC</p> <p>0.01µF</p> <p>2.2µF</p> <p>1.5kΩ</p> <p>71MΩ</p> <p>0.01µF</p> <p>SV3</p> <p>SV2</p> <p>0V</p> <p>t1</p> <p>t2</p> <p>t3</p>
		t2	OFF	b	OFF	b	d	OFF	
		t3	OFF	b	OFF	b	d	OFF	

TA8718N-24

1990-10-24

TOSHIBA CORPORATION

NOTE	CHARACTERISTIC	SYMBOL	TEST CONDITION							TEST METHOD
			SW2	SW7a	SW7b	SW7c	SW8	SW9	Color Contrast	
39	Color Differential Signal Output level	v _{22R}	OFF	a	ON	a	d	OFF	Max.	Input "10" color bar signal and measure R, G and B output levels.
		v _{23G}	OFF	a	ON	a	d	OFF	Max.	
		v _{24B}	OFF	a	ON	a	d	OFF	Max.	
40	Relative Ratio	v _{R/B}	OFF	a	ON	a	d	OFF		$v_{R/B} = \frac{v_{22R}}{v_{24B}}, v_{G/B} = \frac{v_{23G}}{v_{24B}}$
		v _{G/B}	OFF	a	ON	a	d	OFF		
41	Relative Phase	v _{R-B}	OFF	a	ON	a	d	OFF		Input "10" color bar signal and measure phase differences of R, G and B.
		v _{G-B}	OFF	a	ON	a	d	OFF		
41	Residual Carrier	v _{RSC}								(1) Yin, Chroma In : no signal (2) Measure residual carrier of R, G and B outputs.
		v _{GSC}	OFF	a b	ON OFF	a b	d b	OFF		
		v _{BSC}								
42	Output Harmonics	v _{RHC}	OFF	a	ON	a	d	OFF	Adj.	(1) Input "10" color bar signal. (2) Adjust Color and Contrast controls to set B-Y output to be 2Vp-p. (3) Measure output harmonics of B-Y, R-Y and G-Y
		v _{GHC}	OFF	a	ON	a	d	OFF	Adj.	
		v _{BHC}	OFF	a	ON	a	d	OFF	Adj.	

TA8718N-25

1990-10-24

TOSHIBA CORPORATION

Deflection Stage: Test Circuit 3

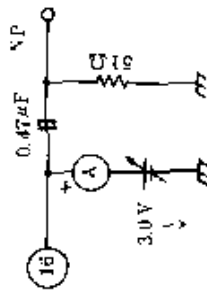
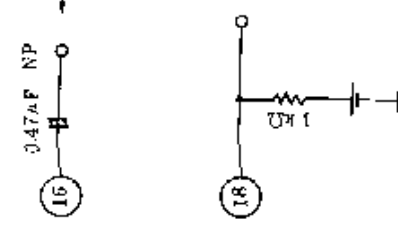
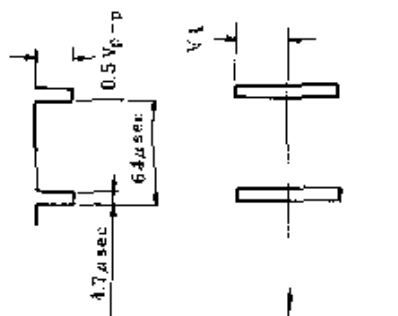
NOTE	CHARACTERISTIC	SYMBOL	TEST CONDITION			TEST METHOD
			SW3	SW4	SW5	
43	Sync. Sepa. Input Current Sensitivity	IIN16	OFF	ON	ON	<p>Measure the current flows into #16 when signal frequency at P13A changes into 268.25K from 353K.</p> 
44	H. AFC Phase Detector Current	IDET	OFF	OFF	ON	 <p>(1) Measure DC voltage at #18 with no component, and apply that voltage to #18 with 1kΩ.</p> <p>(2) Measure V1, IDET=V1÷1kΩ.</p> 

TA8718N-26

1990-10-24





TOSHIBA CORPORATION

NOTE	CHARACTERISTIC	SYMBOL	TEST CONDITION					TEST METHOD
			SW3	SW4	SW5			
45	H. AFC Masking Period	T6018	OFF	ON	ON		<p>0.47µF NP 1V, 50Hz 2Vp-p</p> <p>Measure H. AFC masking period at #18.</p>	
46	32fH VCO Starting Voltage	VON	OFF	ON	ON		<p>2.0V Monitor Point</p> <p>Measure DC voltage at #21 when 32fH VCO starts, while VCC=0V.</p>	
47	H. Output Starting Voltage	VON20	OFF	ON	ON		<p>Measure DC voltage at #21 when H. out starts, while VCC=0V.</p>	
48	Horizontal Free-running Frequency	f _o	OFF	ON	ON		<p>(1) Sync. Sepa. In ; no signal (2) Measure signal frequency at #20.</p>	
49	Horizontal Frequency Control Range	f _{max} f _{min}	OFF	ON	ON		<p>10kΩ 68kΩ H. VCC f_{max} f_{min}</p> <p>Measure signal frequencies f_{max} and f_{min} at #20.</p>	

TA8718N-27

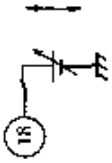
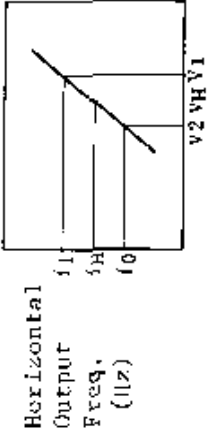
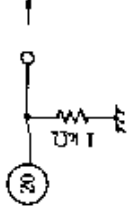
1990-10-24

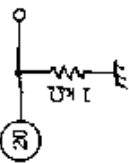
TOSHIBA CORPORATION

NOTE	CHARACTERISTIC	SYMBOL	TEST CONDITION					TEST METHOD
			SW3	SW4	SW5	V, R5		
50	Horizontal Frequency Control Sensitivity	H	OFF	ON	ON	-	 <p>(1) Apply DC voltage at #18 and adjust the voltage so that the output frequency at #20 becomes 15.625kHz. (V18=VH)</p> <p>(2) Change the voltage at #18 by $\pm 0.1V$ and measure the output frequency at #20.</p>  <p>Horizontal Output Freq. (Hz)</p> <p>$f_H = 15.625\text{kHz}$ $V_2 - V_H = 0.05V$ $V_1 - V_H = 0.05V$ $P = \frac{f_1 - f_2}{0.1}$</p> <p>AFC Filter #18 (V)</p>	
51	H. Output Duty-Cycle	T20	OFF	ON	ON	-	  <p>$T20 = \frac{t_1}{t_1 + t_2} \times 100 (\%)$</p>	
52	H. Output Level	VH20 VL20	OFF	ON	ON	-	  <p>VH20 VL20</p>	

TA8718N-28

1990-10-24

TOSHIBA CORPORATION

NOTE	CHARACTERISTIC	SYMBOL	TEST CONDITION					TEST METHOD
			SW3	SW4	SW5	V.R.5		
53	Horizontal Phase Adjustment Range	Δ CL5	ON	ON	ON	Max. Min.	<p>(1) Vary V.R.5 from max. to min. (2) Measure change of pulse timing at #17 against #16 signal.</p>	
54	Horizontal/Phase Shift with 50/60 Switching	CL7	OFF	ON	ON		<p>Measure change of pulse timing at #17 against #16 signal.</p>	
55	Vertical Retrace Pulse Period	T_{r1} T_{r2}	OFF	ON	ON		<p>#13 wave form</p>	

TA8718N-29

1990-10-24

TOSHIBA CORPORATION

NOTE	CHARACTERISTIC	SYMBOL	TEST CONDITION			TEST METHOD
			SM3	SM4	SM5	
56	Peak Voltage of Ramp Wave	V _{H13}	OFF	ON	ON	<p>Measure voltage at #13.</p> <p>V_{H13}</p> <p>0V</p>
57	Ramp Output Current	I _{OUT3}	OFF	ON	ON	<p>$I_{OUT3} = V + 5.1k\Omega$</p> <p>A Point Waveform</p>
58	Vertical Amplifier Gain	G _V	OFF	ON	ON	<p>Measure DC voltage at #11.</p> <p>Vertical Output #11 (V)</p> <p>$G_V = \frac{\Delta V_{11}}{\Delta V_{14}}$ (dB)</p> <p>V. NFB #14 (V)</p>

TA8718N-30

1990-10-24

TOSHIBA CORPORATION

NOTE	CHARACTERISTIC	SYMBOL	TEST CONNECTION			TEST METHOD	
			SW3	SW4	SW5		
59	Vertical Output Maximum Voltage	VH11	ON	ON	ON	<p>Measure DC voltage at #11.</p>	
		VLL1	OFF	ON	ON	<p>Measure DC voltage at #11.</p>	
60	Vertical Output Minimum Voltage	LO11	ON	ON	OFF	<p>Measure output current at #11.</p>	
			ON	ON	ON	<p>Measure output current at #11.</p>	
62	Vertical Pull-in Range	fPV1	ON	ON	ON	<p>1V : 50Hz, 60Hz</p>	
							50Hz
		fPV2				60Hz	<p>1V : 50Hz, 60Hz</p>
63	Vertical Pull-in Range	fPV3	ON	ON	ON	<p>1V : 50Hz, 60Hz</p>	
		fPV4					

TA8718N-31

1990-10-24

TOSHIBA CORPORATION

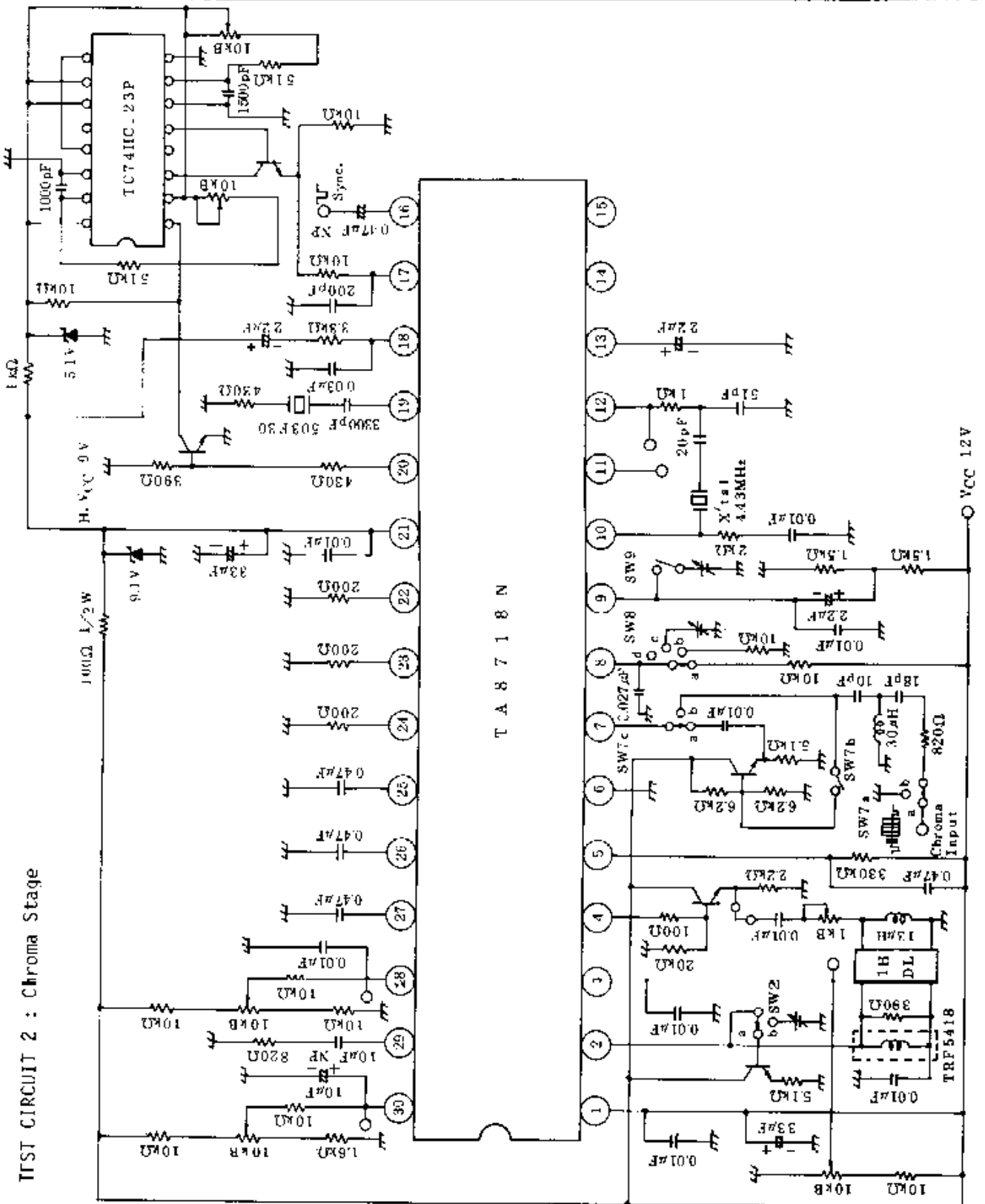

TEST CIRCUIT 2 : Chroma Stage

TA8718N-33
 1990-10-24
 TOSHIBA CORPORATION

TEST CIRCUIT 3 : Deflection Stage

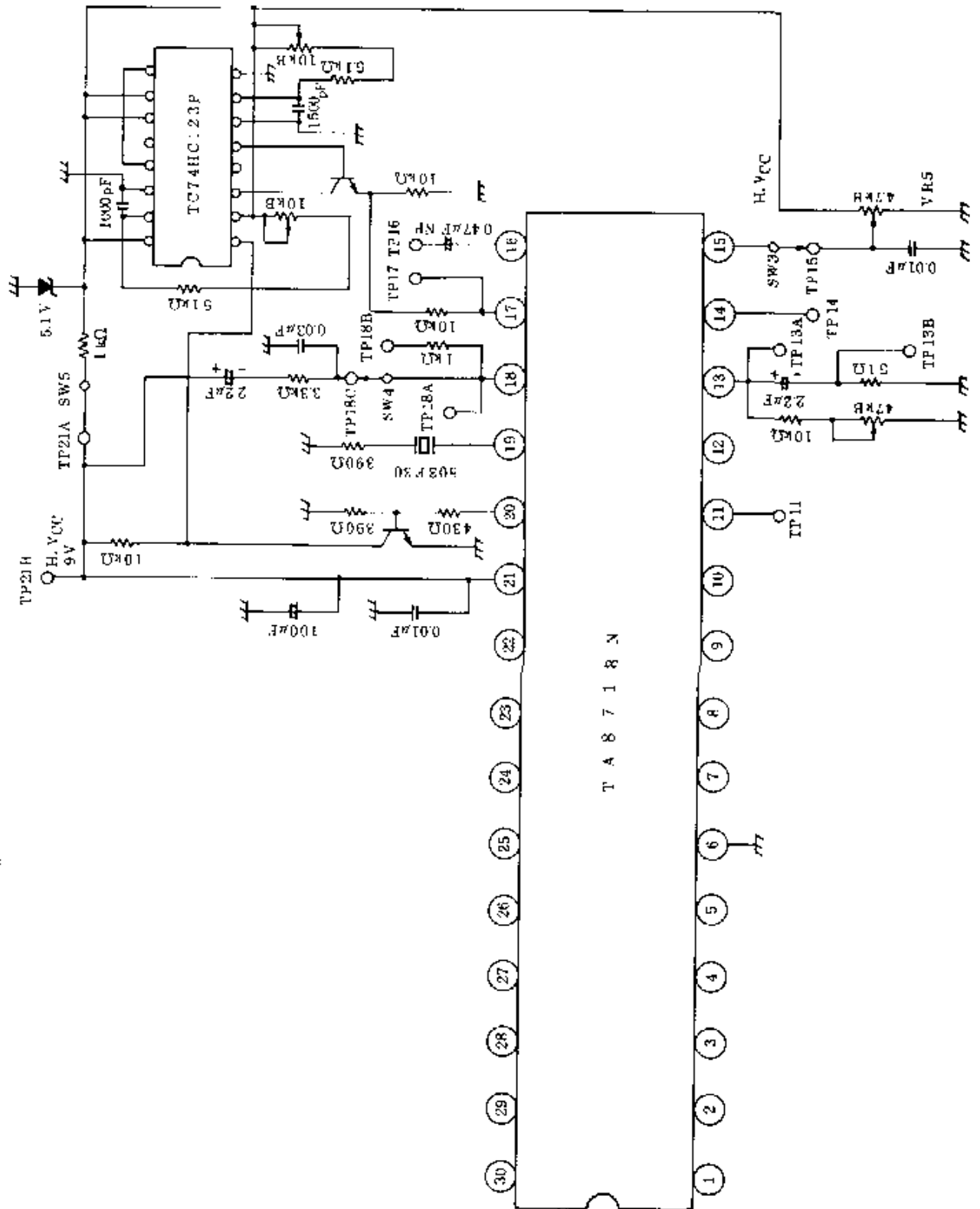

TA8718N-34

1990-10-24

TOSHIBA CORPORATION

TERMINAL FUNCTION AND INTERNAL INTERFACE ($V_{CC}=12V$, H. $V_{CC}=9V$)

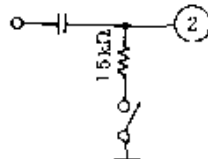
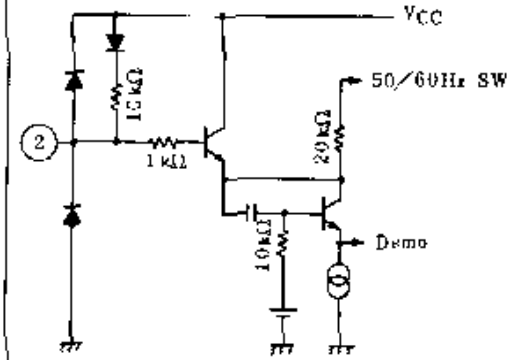
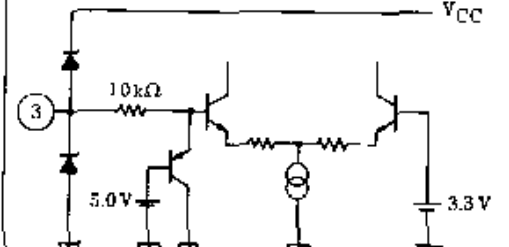
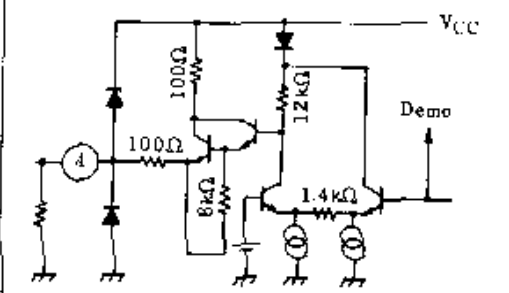
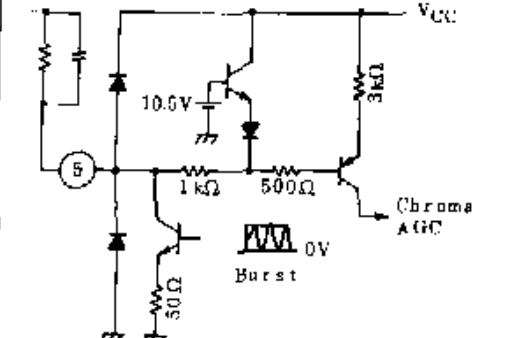
No.	TERMINAL	FUNCTION	INTERFAC
1	V_{CC}	Video and Chroma stage $V_{CC}=12V$ (Typ.)	
2	DLin	An input terminal for LH delayed chroma signal and a select SW for vertical frequency (50Hz or 60Hz)  <p>ON : 60Hz OFF : 50Hz $V_{1b}=9.5V$</p>	
3	Color	Color control terminal	
4	DLout	An output terminal for chroma signal to drive IR glass delay line. A delay line of -16dB loss should be used.	
5	ACC Filter	ACC filter capacitance is connected.	

TA8718N-35

1990-10-24

TOSHIBA CORPORATION

No.	TERMINAL	FUNCTION	INTERFACE
6	GND	Video, Chroma and Deflection stage GND	
7	Chroma in	An input terminal for chroma signal. Typical Burst level is 100mVp-p.	
8	Killer Filter	Killer ident filter capacitance is connected. The killer threshold is 6.4V typ. (In the B/W Mode, this terminal voltage is lower than this threshold voltage)	
9	APC Filter	APC filter capacitance is connected.	

TA8718N-36

1990-10-24

TOSHIBA CORPORATION

No.	TERMINAL	FUNCTION	INTERFACE
10 12	VCX0in VCX0out	A fsc X'tal is connected between #10 and #12. #12 is a drive output and #10 is an input.	
11	Vout	An output terminal for a vertical deflection drive circuit. This terminal also has Service SW function.	
13	V.Ramp	The vertical ramp wave is generated at this terminal. During retrace period, an external capacitor is charged by an internal current source, then, during trace period, the external capacitor is discharged by an external resistor. The V.ramp voltage is subjected to the horizontal Vcc(7.6V(Typ) when H.Vcc=9V)	
14	V.NFB	An input terminal for AC and DC negative feedback of vertical deflection drive circuit.	

TA8718N-37

1990-10-24

TOSHIBA CORPORATION

No.	TERMINAL	FUNCTION	INTERFACE
15	Horizontal Phase adj.	Horizontal output pulse phase is connected by the DC voltage applied #15. The adjustable range is 2μsec.	
16	Sync. Sep. in	An input terminal for a composite sync. signal. The sync. signal separated at this terminal can be observed at terminal #17.	
17	H. Blank	An input terminal of the F.B.P for H.Blanking and PAL SW driving pulse. Blanking threshold voltage is 1.4V (Typ.). The sync pulse output can be obtained at this terminal for a station detector. 	
18	AFC Filter	AFC filter capacitance is connected.	

TA8718N-38
1990-10-24

TOSHIBA CORPORATION

No.	TERMINAL	FUNCTION	INTERFACE
19	32f _H VCO	An output terminal for 32f _H ceramic oscillator driver.	
20	H _{out}	An emitter follower output terminal for Horizontal drive pulse. Duty cycle is 43%.	
21	H.VCC	V _{CC} for a horizontal deflection stage H.VCC=9V(Typ.) External zener diode is required.	
22 23 24	R _{out} G _{out} R _{out}	An output terminal for R.C.B primary color signals.	

TA8718N-39

1990-10-24

TOSHIBA CORPORATION

No.	TERMINAL	FUNCTION	INTERFACE
25 26 27	R Clamp/OSD in G Clamp/OSD in B Clamp/OSD in	Clamp capacitor for DC restoration is connected. An On-Screen-Display signal can be applied through a coupling capacitance (TTL level).	
28	Brightness	Brightness control terminal. If this terminal is Low (<0.3V), R.G.B output signals are muted and the output DC voltage is clamped to 3.2V.	
29	Yin	This is an Input terminal for Video signal.	
30	Uni-Color	Uni-Color control terminal. A luminance signal amplitude and a chrominance signal amplitude are controlled Simultaneously by the DC voltage applied at #30.	

TA8718N-40

1990-10-24

TOSHIBA CORPORATION

PCB CIRCUIT (supplied by TOSHIBA Corp.)

NP : Non-polarity Capacitor
M : Film Capacitor
is recommended.

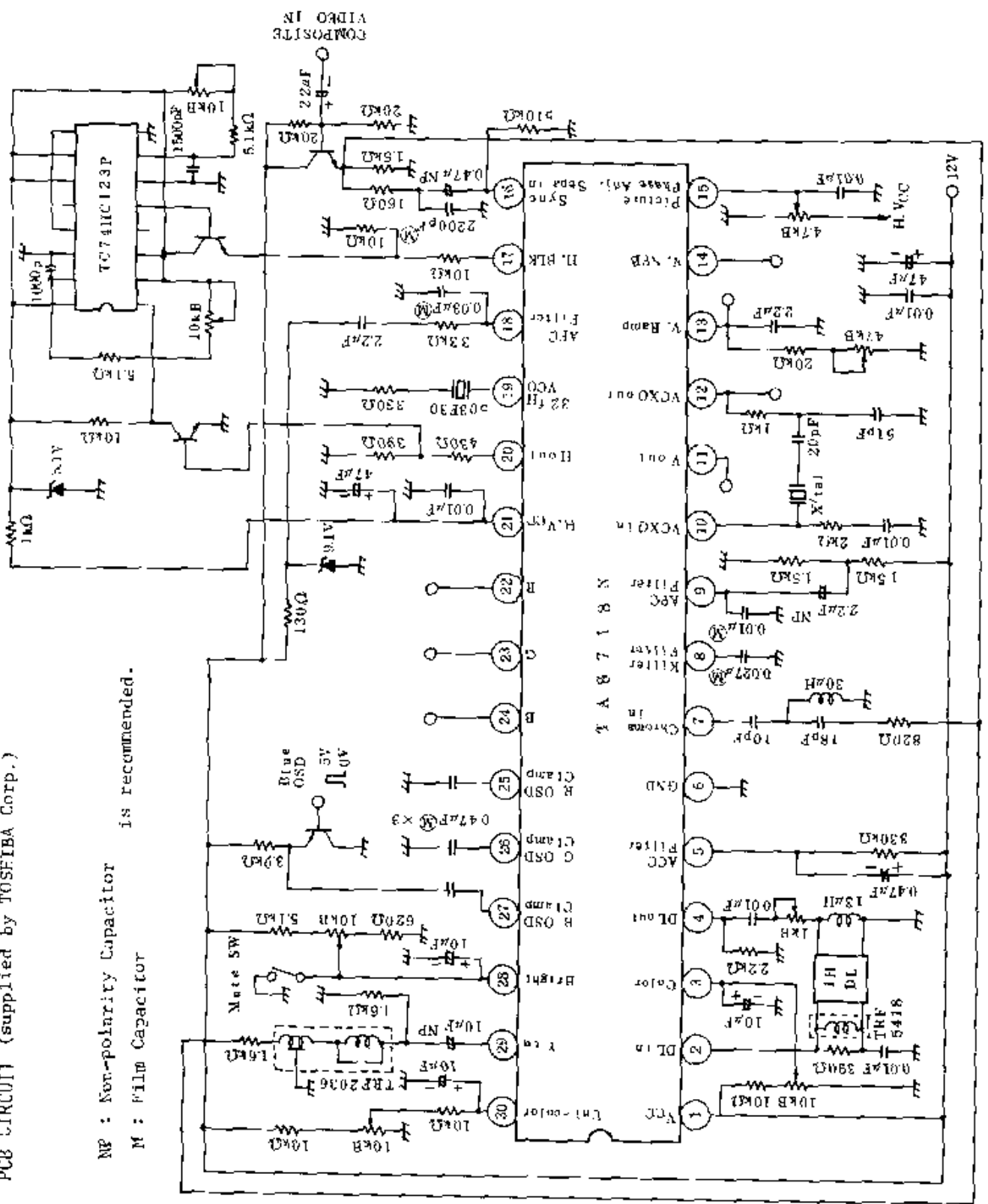

TA8718N-41

1990-10-24

TOSHIBA CORPORATION

APPLICATION CIRCUIT

NP : Non-polarity N : Film capacitance

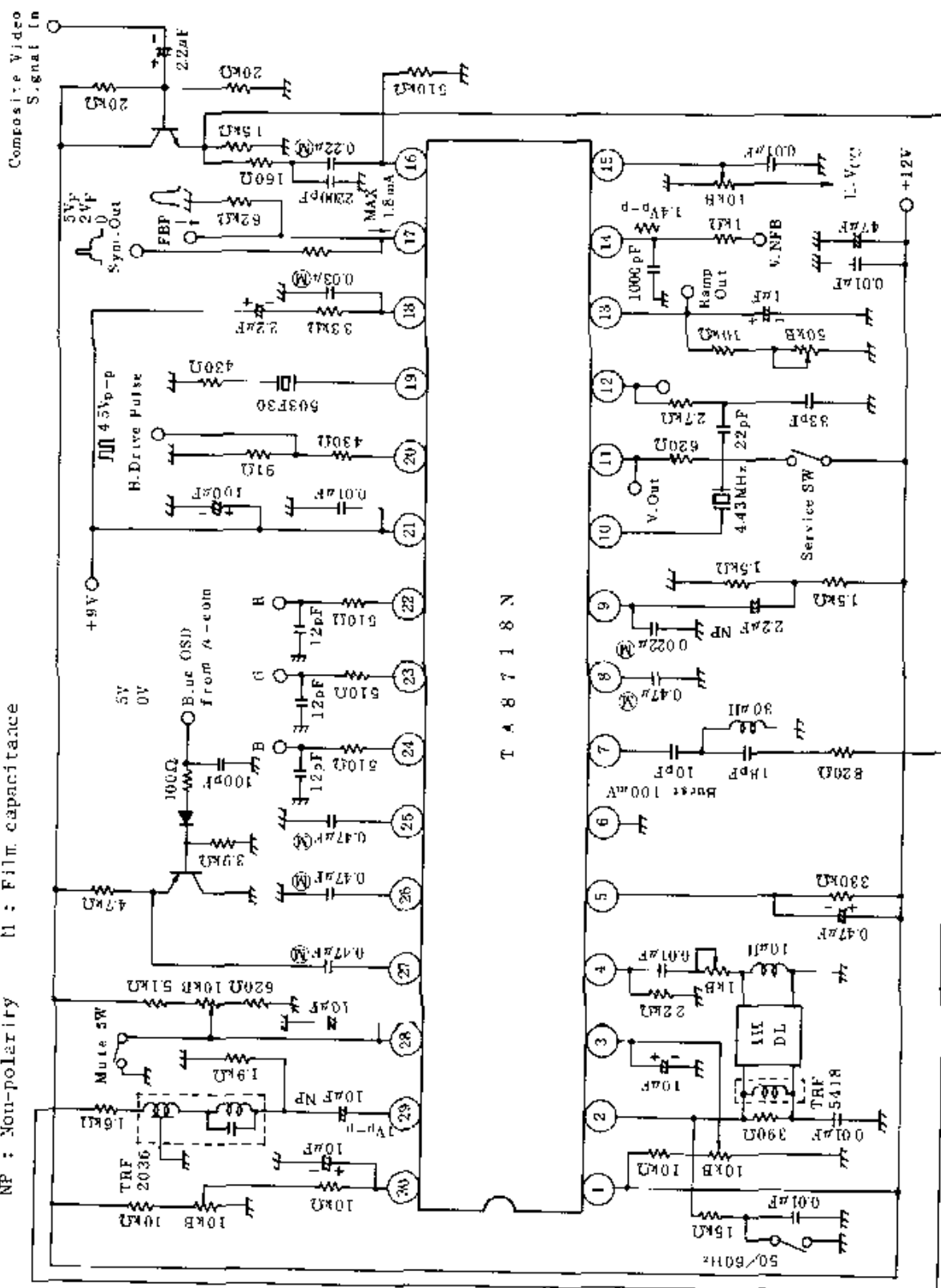

TA8718N

TA8718N-42

1990-10-24

TOSHIBA CORPORATION

LH Delay Line Adjustment Procedure

- (1) #29: open
- (2) #28: 5V
- (3) #3: max.
- (4) Adjust contrast control to set Red and Blue outputs, at #22 and #24 respectively, less than 4Vp-p, so that the ACL function does not work. Under this condition, R-Y and B-Y signals come out from #22 and #24.
- (5) Apply Philips color pattern signal at #7, the burst level should be set to 100mVp-p.
- (6) Adjust a volume and a tank-coil (TRF5418) so as to minimize color at Anti-Pal region and Venetian Blind at color bar.