

## DO-27 Plastic-Encapsulate Diodes

## Schottky Rectifier

## Features

- $I_o$  3.0A
- $V_{RRM}$  20V-100V
- High surge current capability
- Polarity: Color band denotes cathode

## Applications

- Rectifier

## Marking

- SR3XX  
XX:From 20 to 100

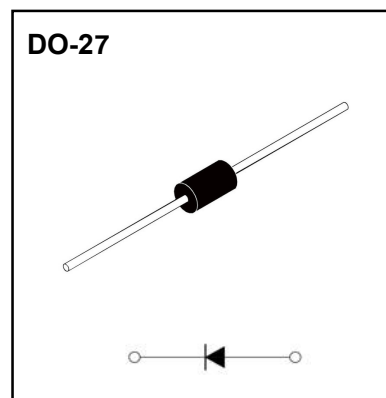

## Limiting Values (Absolute Maximum Rating)

Item	Symbol	Unit	Conditions	SR3						
				20	30	40	50	60	80	100
Repetitive Peak Reverse Voltage	$V_{RRM}$	V		20	30	40	50	60	80	100
Maximum RMS Voltage	$V_{RMS}$	V		14	21	28	35	42	56	70
Average Forward Current	$I_{F(AV)}$	A	60Hz Half-sine wave, Resistance load, TL(Fig.1)	3.0						
Surge(Non-repetitive)Forward Current	$I_{FSM}$	A	60Hz Half-sine wave, 1 cycle, $T_a=25^\circ\text{C}$	80						
Junction Temperature	$T_J$	$^\circ\text{C}$		-55~+125						-55 ~ +150
Storage Temperature	$T_{STG}$	$^\circ\text{C}$		-55 ~ +150						

Electrical Characteristics ( $T_a=25^\circ\text{C}$  Unless otherwise specified)

Item	Symbol	Unit	Test Condition	SR3						
				20	30	40	50	60	80	100
Peak Forward Voltage	$V_{FM}$	V	$I_{FM}=3.0\text{A}$	0.55			0.7		0.85	
Peak Reverse Current	$I_{RRM1}$	mA	$V_{RM}=V_{RRM}$	$T_a=25^\circ\text{C}$			0.1			
	$I_{RRM2}$			$T_a=125^\circ\text{C}$			10			
Thermal Resistance(Typical)	$R_{\theta J-A}$	$^\circ\text{C/W}$	Between junction and ambient		40					
	$R_{\theta J-L}$		Between junction and lead		10					

## Typical Characteristics

FIG. 1: FORWARD CURRENT DERATING CURVE

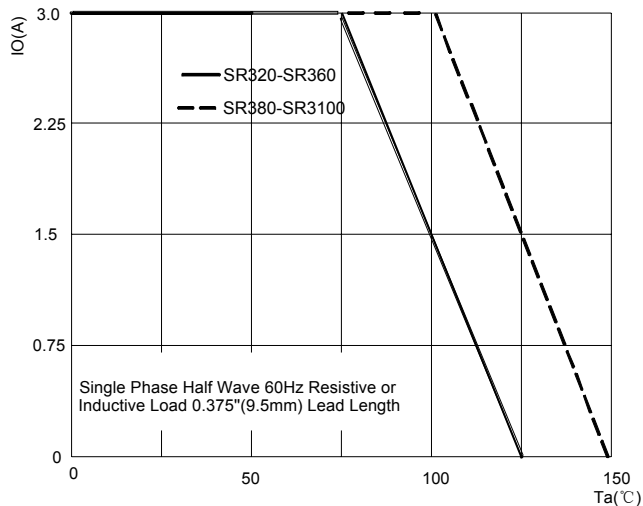

FIG. 2: MAXIMUM NON-REPETITIVE FORWARD SURGE CURRENT

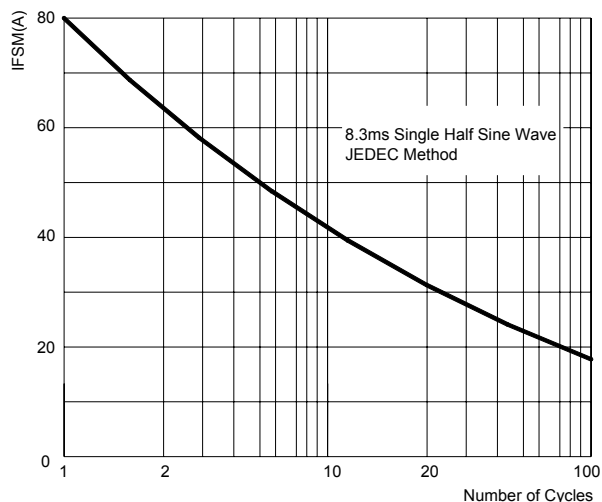

FIG. 3: TYPICAL FORWARD CHARACTERISTICS

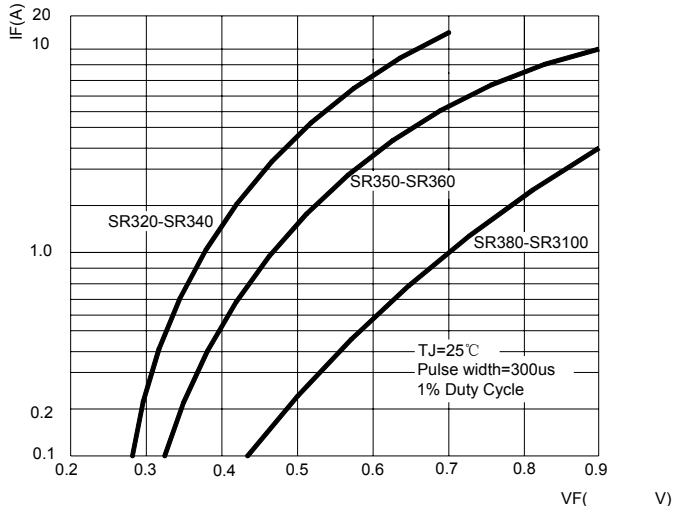
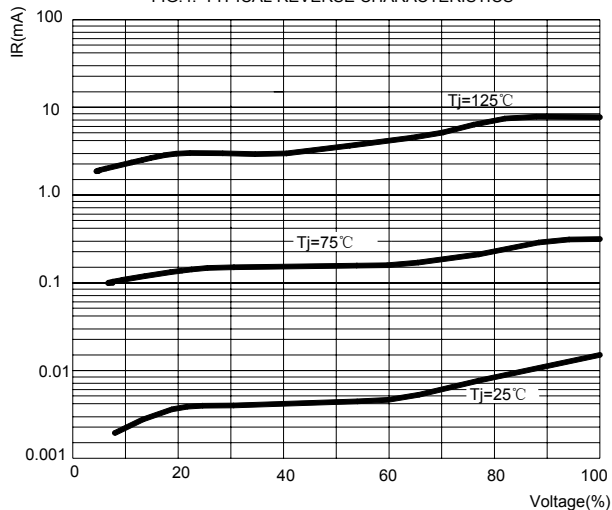
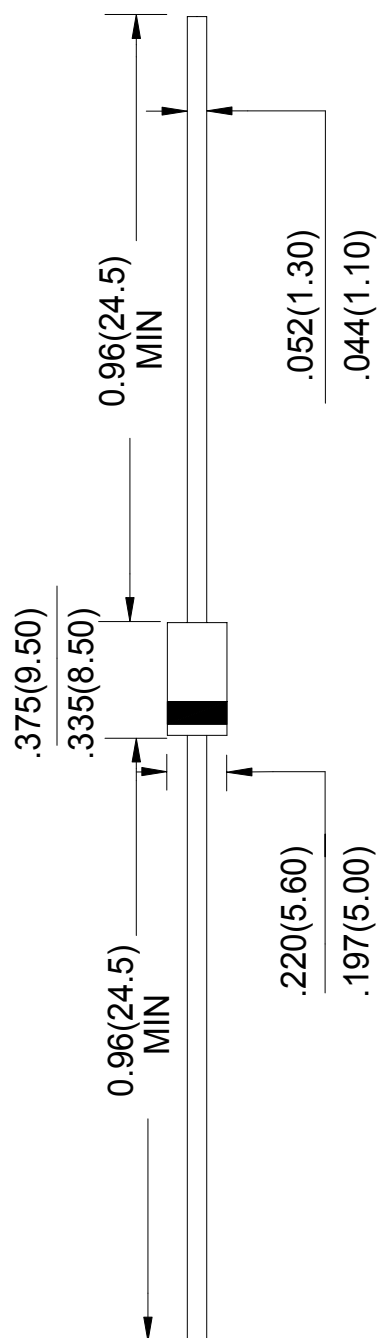

FIG. 4: TYPICAL REVERSE CHARACTERISTICS



**DO-27 Package Outline Dimensions**

Unit: in inches (millimeters)

**NOTICE**

JSMD reserve the right to make modifications, enhancements, improvements, corrections or other changes without further notice to any product herein. JSMD does not assume any liability arising out of the application or use of any product described herein.

## Ammo Box Packaging Specifications For Axial Lead Rectifiers

Axial lead devices are packed in accordance with EIA standard RS-296-D and specifications given below

COMPONENT OUTLINE	COMPONENT PITCH A	INNER TAPE PITCH B	CUMULATIVE PITCH TOLERANCE
	$\pm 0.5\text{mm}(0.020\text{'})$	$+0.5\text{mm}(0.020\text{'})$	
R-1	5.0mm	26.0mm	2.0mm/20pitch
R-1	5.0mm	52.4mm	2.0mm/10pitch
A-405	5.0mm	26.0mm	2.0mm/20pitch
A-405	5.0mm	52.4mm	2.0mm/10pitch
DO-34/DO-35	5.0mm	26.0mm	2.0mm/20pitch
DO-34/DO-35	5.0mm	52.4mm	2.0mm/10pitch
DO-41	5.0mm	26.0mm	2.0mm/20pitch
DO-41	5.0mm	52.4mm	2.0mm/10pitch
DO-15	5.0mm	52.4mm	2.0mm/10pitch
DO-27	10.0mm	52.4mm	2.0mm/10pitch
R-6	10.0mm	52.4mm	2.0mm/10pitch

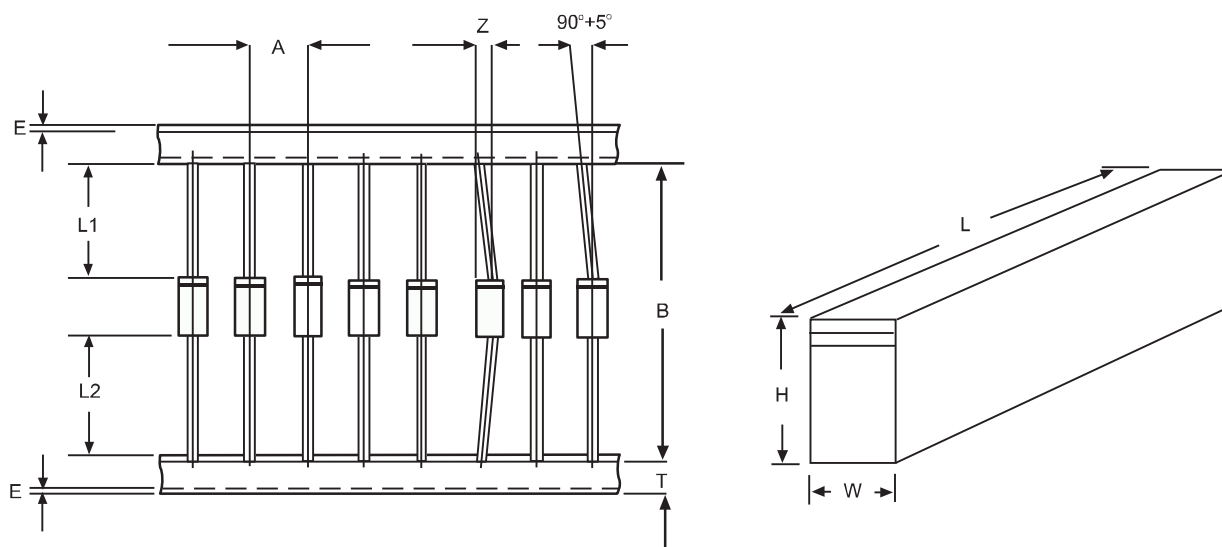

ITEM	SYMBOL	SPECIFICATIONS(mm)	SPECIFICATIONS(inch)
Component alignment	Z	1.2max	0.048max
Tape width	T	$6.0\pm 0.4$	$0.236\pm 0.016$
Exposed adhesive	E	0.8max	0.032max
Body eccentricity	$ L1-L2 $	1.0max	0.040max
Box length	L	$255.0\pm 5.0$	$10.04\pm 0.197$
Box width	W	$78.0\pm 5.0$	$3.07\pm 0.197$
Box height	H	$150.0\pm 5.0$	$5.91\pm 0.197$

NOTE: Each component lead shall be sandwiched between tapes for A minimum of 3.2mm(0.126'')