

SF11 THRU SF18

Features

- High reliability
- High current capability
- Low forward voltage drop
- High surge capability

Maximum Ratings

- Operating Temperature: -55°C to +125°C
- Storage Temperature: -55°C to +150°C
- For capacitive load, derate current by 20%

Part Number	Maximum Recurrent Peak Reverse Voltage	Maximum RMS Voltage	Maximum DC Blocking Voltage
SF11	50V	35V	50V
SF12	100V	70V	100V
SF13	150V	105V	150V
SF14	200V	140V	200V
SF15	300V	210V	300V
SF16	400V	280V	400V
SF18	600V	420V	600V

Electrical Characteristics @ 25°C Unless Otherwise Specified

Average Forward Current	$I_{F(AV)}$	1.0A	$T_C = 55^\circ\text{C}$
Peak Forward Surge Current	I_{FSM}	30A	8.3ms, half sine
Maximum Instantaneous Forward Voltage SF11-SF14 SF15-SF18	V_F	0.95V 1.3V	$I_{FM} = 1.0\text{A};$ $T_C = 25^\circ\text{C}$
Maximum DC Reverse Current At Rated DC Blocking Voltage	I_R	5.0uA 100uA	$T_C = 25^\circ\text{C}$ $T_C = 100^\circ\text{C}$
Typical Junction Capacitance SF11-SF14 SF15-SF18	C_J	30pF 25pF	Measured at 1.0MHz, $V_R=4.0\text{V}$
Maximum Reverse Recovery Time	T_{RR}	35nS	$I_F=0.5\text{A}, I_R=1.0\text{A},$ $I_{RR}=0.25\text{A}$

Pulse Test: Pulse width 300 usec, Duty cycle 1%.

1.0 Amp Super Fast Rectifier 50 to 600 Volts

DO-41

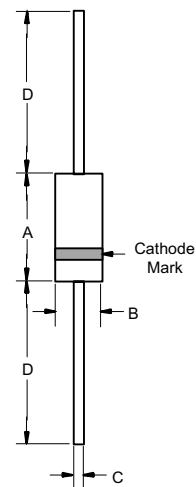

DIM	INCHES		MM		NOTE
	MIN	MAX	MIN	MAX	
A	.166	.205	4.10	5.20	
B	.080	.107	2.00	2.70	
C	.028	.034	.70	.90	
D	1.000	---	25.40	---	

SF11 thru SF18

Figure 1
Typical Reverse Characteristics

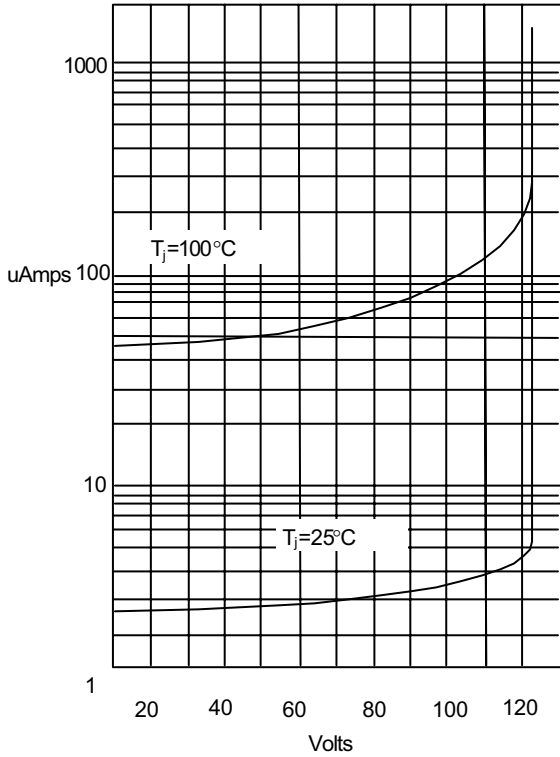

Instantaneous Reverse Current - uAmperes versus
Percent of Rated Peak Reverse Voltage - %

Figure 2
Typical Forward Characteristics

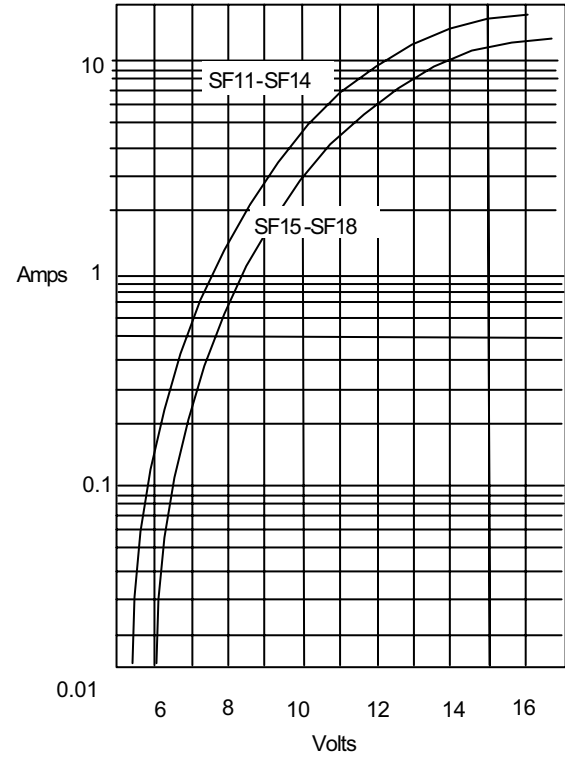

Instantaneous Forward Current - Amperes versus
Instantaneous Forward Voltage - Volts

Figure 3
Forward Derating Curve

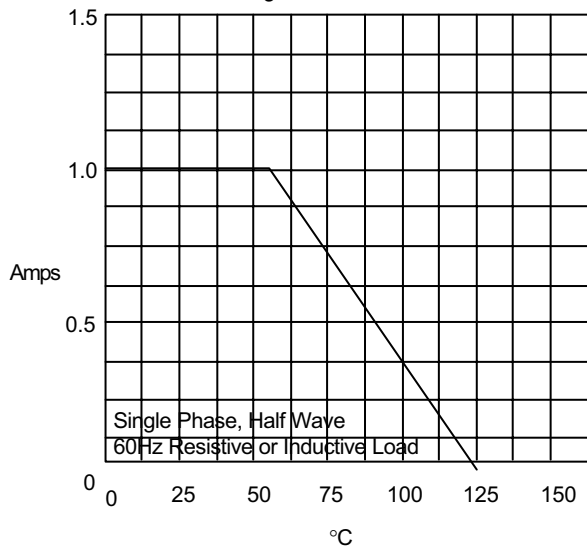

Average Forward Rectified Current Per Leg - Amperes versus
Case Temperature - $^\circ\text{C}$

SF11 thru SF18

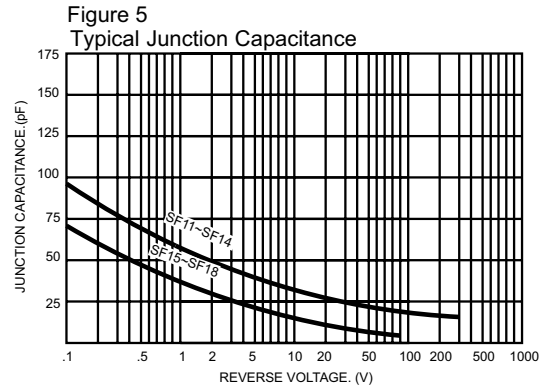
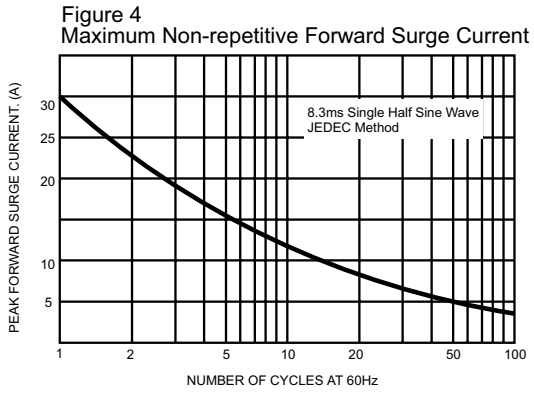

Figure 6
Reverse Recovery Time Characteristic And Test Circuit Diagram

