

SCHOTTKY BARRIER RECTIFIERS

REVERSE VOLTAGE - 30 to 60 Volts
FORWARD CURRENT - 16 Amperes

FEATURES

- Metal of silicon rectifier, majority carrier conduction
- Guard ring for transient protection
- Low power loss, high efficiency
- High current capability, low VF
- High surge capacity
- Plastic package has UL flammability classification 94V-0
- For use in low voltage, high frequency inverters, free wheeling, and polarity protection applications

MECHANICAL DATA

- Case : TO-220AC molded plastic
- Polarity : As marked on the body
- Weight : 0.08 ounces, 2.24 grams
- Mounting position : Any
- Max. mounting torque = 0.5 N.m (5.1 Kgf.cm)

TO-220AC

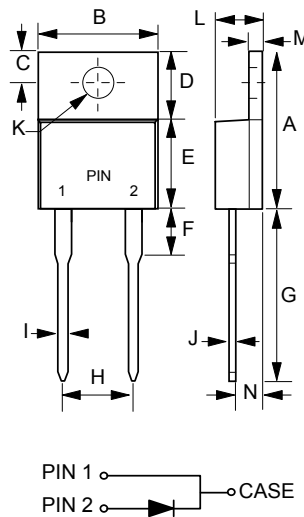

TO-220AC		
DIM.	MIN.	MAX.
A	14.22	15.88
B	9.65	10.67
C	2.54	3.43
D	5.84	6.86
E	8.26	9.28
F	-	6.35
G	12.70	14.73
H	4.83	5.33
I	0.51	1.14
J	0.30	0.64
K	3.53 \varnothing	4.09 \varnothing
L	3.56	4.83
M	1.14	1.40
N	2.03	2.92

All Dimensions in millimeter

MAXIMUM RATINGS AND ELECTRICAL CHARACTERISTICS

Ratings at 25°C ambient temperature unless otherwise specified.
Single phase, half wave, 60Hz, resistive or inductive load.
For capacitive load, derate current by 20%

CHARACTERISTICS	SYMBOL	SBL1630	SBL1635	SBL1640	SBL1645	SBL1650	SBL1660	UNIT
Maximum Recurrent Peak Reverse Voltage	VRRM	30	35	40	45	50	60	V
Maximum RMS Voltage	VRMS	21	24.5	28	31.5	35	42	V
Maximum DC Blocking Voltage	VDC	30	35	40	45	50	60	V
Maximum Average Forward Rectified Current (See Fig.1) @TC=95°C	IAV	16						A
Peak Forward Surge Current 8.3ms single half sine-wave superimposed on rated load	IFSM	275						A
Maximum Forward Voltage at 16A DC (Note 1)	VF	0.57				0.75		V
Maximum DC Reverse Current at Rated DC Blocking Voltage @TJ=25°C @TJ=100°C	IR	1				50		mA
Typical Junction Capacitance (Note 2)	CJ	600						pF
Typical Thermal Resistance (Note 3)	RθJC	1.5						°C/W
Operating Temperature Range	TJ	-55 to +125						°C
Storage Temperature Range	TSTG	-55 to +150						°C

NOTES : 1. 300us Pulse Width, 2% Duty Cycle.
2. Measured at 1.0MHz and applied reverse voltage of 4.0V DC.
3. Thermal Resistance Junction to Case.

FIG.1 - FORWARD CURRENT DERATING CURVE

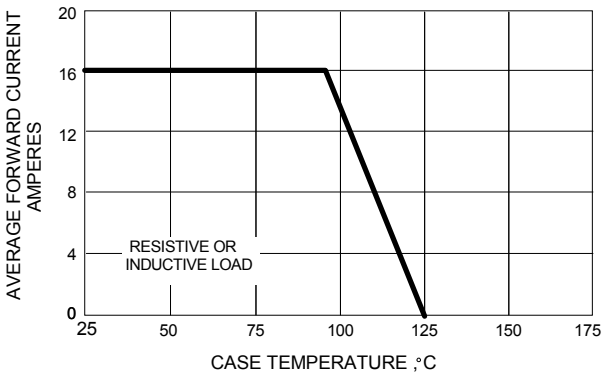

FIG.2 - MAXIMUM NON-REPETITIVE SURGE CURRENT

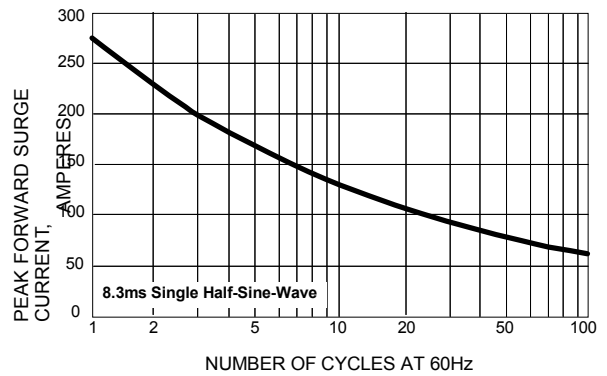

FIG.3 - TYPICAL REVERSE CHARACTERISTICS

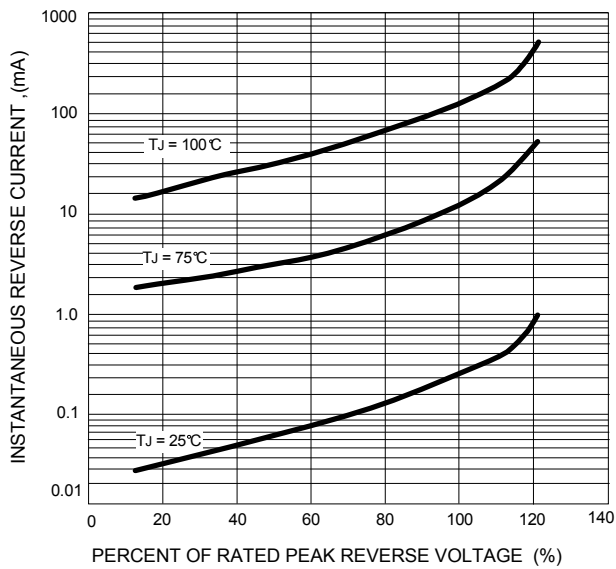

FIG.4 - TYPICAL FORWARD CHARACTERISTICS

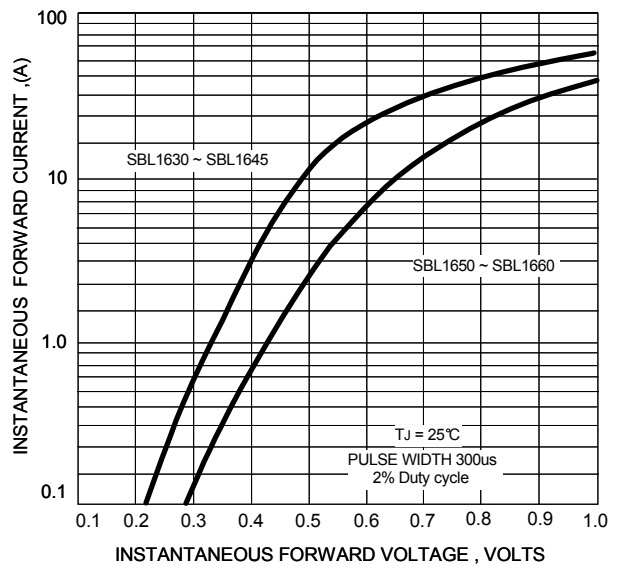

FIG.5 - TYPICAL JUNCTION CAPACITANCE

