

5-Bit Programmable Synchronous PWM Buck Converter Controller and Output Voltage Monitor

General Description

The RT9224 is a high speed switching controller designed for use in synchronous DC/DC buck converter for modern CPUs. The regulated output voltage is digitally programmable from 1.3V to 3.5V by a 5-bit DAC which provides initial accuracy of $\pm 1\%$. The RT9224 drives two external N-channel MOSFETs, providing high efficiency and eliminating the need for high cost P-channel devices. It senses the output current across the on-resistance of the upper N-channel MOSFET and provides an adjustable current limit without external sense resistor.

RT9224 monitors the output voltage and provides the output signal for power-good and over-voltage protection. The switching controller drives two N-MOSFETs at 200kHz frequency and provides an optimal solution for size, efficiency and cost in any application circuits. The high switching frequency cooperating with a high speed error amplifier maintains a fast response to the dynamic load of modern CPUs.

Ordering Information

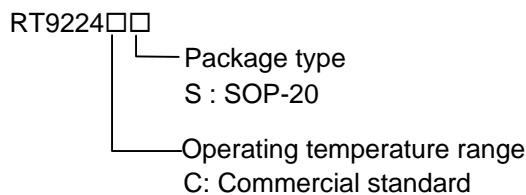

Features

- **Compatible with HIP6004B**
- **Simple Voltage-mode PWM Control with Buck Rectification**
- **$\pm 1\%$ DAC Output Voltage Accuracy**
- **5-Bit Digital-to-Analog Output Voltage Range from 1.3 V to 3.5V**
- **Fast Transient Response and Excellent Output Voltage Regulation**
- **Fault Protection for Over-voltage and Over-current**
- **Power-good Output Voltage Monitor**
- **Fixed 200kHz Switching Frequency**

Applications

- Power Supply for Pentium, Pentium Pro™, Pentium II™, PowerPC™, K6™, 6x86™, and Alpha™ Microprocessors
- Low-voltage Distributed Power Supplies
- High Power 5V to 1.3V~3.5V Switching Regulator

Pin Configurations

Part Number	Pin Configurations
RT9224CS (Plastic SOP-20)	<p style="text-align: center;">TOP VIEW</p> <p>VSEN 1, 20 NC OCSET 2, 19 OVP SS 3, 18 VCC VID0 4, 17 LGATE VID1 5, 16 PGND VID2 6, 15 BOOT VID3 7, 14 UGATE VID4 8, 13 PHASE NC 9, 12 PGOOD FB 10, 11 GND</p>

Absolute Maximum Ratings

- Supply Voltage +15V
- Boot Voltage +15V
- Input, Output or I/O Voltage GND – 0.3V to V_{CC} + 0.3V
- Storage Temperature Range -65°C ~150°C
- Package Thermal Resistance
SOP-20,θ_{JA} 87°C/W

Recommended Operating Conditions

- Supply Voltage, V_{CC} +12V±10%
- Ambient Temperature Range 0°C to 70°C
- Junction Temperature Range 0°C to 125°C

Electrical Characteristics

(T_A = 25°C, recommended operating conditions, unless otherwise specified)

Parameter	Symbol	Test Conditions	Min	Typ	Max	Units
VCC Supply Current						
Nominal Supply	I _{CC}	UGATE and LGATE Open	--	3	--	mA
Power-On Reset						
VCC Rising Threshold		V _{OCSET} = 4.5V	--	9.5	--	V
VCC Falling Threshold		V _{OCSET} = 4.5V	--	7.5	--	V
Rising V _{OCSET} Threshold			--	1.6	--	V
Oscillator						
Free Running Frequency			170	200	230	KHz
Ramp Amplitude	ΔV _{OSC}		--	1.9	--	V _{P-P}
Reference and DAC						
DAC (VID0 – VID4) Input Low Voltage			--	--	0.8	V
DAC (VID0 – VID4) Input High Voltage			2.0	--	--	V
DACOUT Voltage Accuracy			-1.0	--	+1.0	%
Error Amplifier						
DC Gain			--	65	--	dB
Gate Drivers						
UGATE Source	R _{UGATE}	V _{BOOT} - V _{PHASE} = 12V	--	8	--	Ω
UGATE Sink	R _{UGATE}	V _{UGATE} - V _{PHASE} = 1V	--	5	--	Ω
LGATE Source	I _{LGATE}	V _{CC} = 12V, V _{LGATE} = 6V	--	500	--	mA
LGATE Sink	R _{LGATE}	V _{LGATE} = 1V	--	5	--	Ω

To be continued

Parameter	Symbol	Test Conditions	Min	Typ	Max	Units
Protection						
Over-voltage Trip (VSEN/DACOUT)			--	115	120	%
OCSET Current Source	I _{OCSET}	V _{OCSET} = 4.5V	167	200	233	μA
OVP Sourcing Current	I _{OVP}	V _{SEN} = 5.5V, V _{OVP} = 0V	60	--	--	mA
Soft-Start Current	I _{SS}	V _{SS} = 1.5V	--	10	--	μA
Power Good						
Upper Threshold (VSEN/DACOUT)		VSEN Rising	106	--	114	%
Lower Threshold (VSEN/DACOUT)		VSEN Falling	89	--	96	%
Hysteresis (VSEN/DACOUT)		Upper and Lower Threshold	--	2	--	%
PGOOD Voltage Low	V _{PGOOD}	I _{PGOOD} = -5mA	--	0.5	--	V

Function Block Diagram

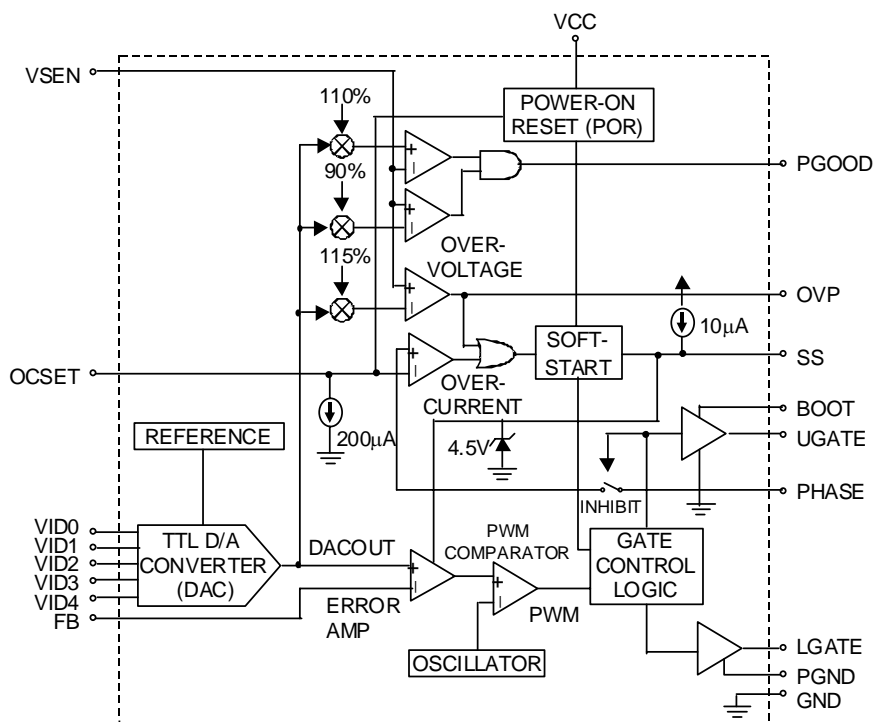

Pin Description

Pin No.	Pin Name	Pin Function
1	VSEN	Output voltage monitoring input for OVP & PGOOD
2	OCSET	Over current set pin, sinks 200μA through a resistor (R _{ocs}) from this pin to upper N-MOSFET to set the trip point: $I_{PEAK} = \frac{200\mu A \times R_{ocs}}{\text{MOSFET-on resistance}}$ An over-current trip cycles the soft-start function
3	SS	Soft start speed is set by internal 10μA current source and capacitor from this pin to GND
4	VID0	Switching Regulator Output Voltage Setting
5	VID1	Switching Regulator Output Voltage Setting
6	VID2	Switching Regulator Output Voltage Setting
7	VID3	Switching Regulator Output Voltage Setting
8	VID4	Switching Regulator Output Voltage Setting
9	NC	No Connection
10	FB	Feedback input pin for the PWM Loop
11	GND	IC Signal Ground
12	PGOOD	Open Drain Logic Output This pin is pulled low when the converter output is not within ±10% of the DACOUT reference voltage
13	PHASE	Current Limit Sense Input
14	UGATE	High Side Driver Output
15	BOOT	Driver Power
16	PGND	Low Side Driver GND
17	LGATE	Low Side Driver Output
18	VCC	Power Supply Input
19	OVP	Over Voltage Protection This pin is pulled high when the VSEN voltage is over 15% of the DACOUT reference voltage
20	NC	No Connection

Table 1 Output Voltage Program

Pin Name					Nominal Output Voltage DACOUT	Pin Name					Nominal Output Voltage DACOUT
VID4	VID3	VID2	VID1	VID0		VID4	VID3	VID2	VID1	VID0	
0	1	1	1	1	1.30V	1	1	1	1	1	2.0V
0	1	1	1	0	1.35V	1	1	1	1	0	2.1V
0	1	1	0	1	1.40V	1	1	1	0	1	2.2V
0	1	1	0	0	1.45V	1	1	1	0	0	2.3V
0	1	0	1	1	1.50V	1	1	0	1	1	2.4V
0	1	0	1	0	1.55V	1	1	0	1	0	2.5V
0	1	0	0	1	1.60V	1	1	0	0	1	2.6V
0	1	0	0	0	1.65V	1	1	0	0	0	2.7V
0	0	1	1	1	1.70V	1	0	1	1	1	2.8V
0	0	1	1	0	1.75V	1	0	1	1	0	2.9V
0	0	1	0	1	1.80V	1	0	1	0	1	3.0V
0	0	1	0	0	1.85V	1	0	1	0	0	3.1V
0	0	0	1	1	1.90V	1	0	0	1	1	3.2V
0	0	0	1	0	1.95V	1	0	0	1	0	3.3V
0	0	0	0	1	2.00V	1	0	0	0	1	3.4V
0	0	0	0	0	2.05V	1	0	0	0	0	3.5V

Typical Application Circuit

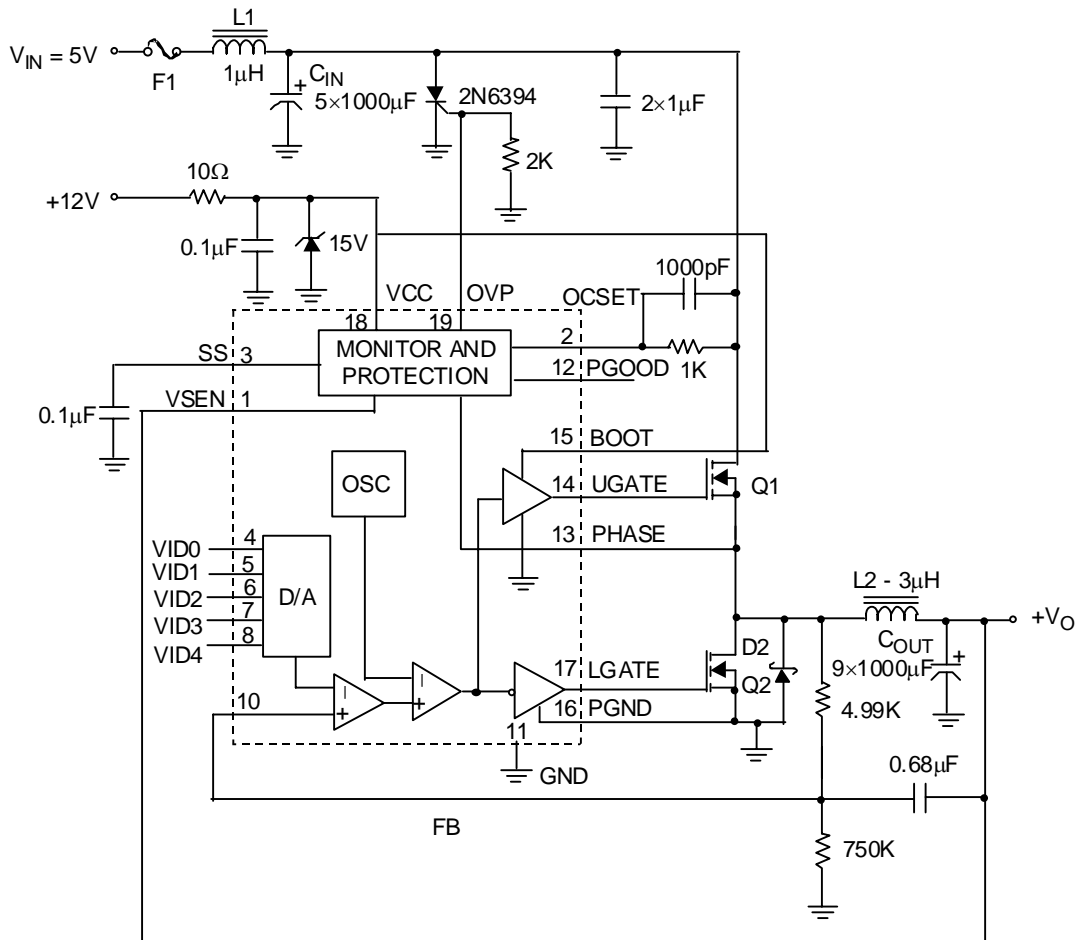

Component Selection Notes:

C_{OUT} , C_{IN} – Each 1000µF 6.3W VDC, Sanyo MV-GX or Equivalent.

L2 – Core: Micrometals T50-52B; Winding: 10 Turns of 16AWG.

L1 – Core: Micrometals T50-52; Winding: 5 Turns of 18AWG.

D2 – 3A, 40V Schottky, Motorola MBR340 or Equivalent.

Q1, Q2 – PHB83N03LT; PHB95N03LT

Package Information

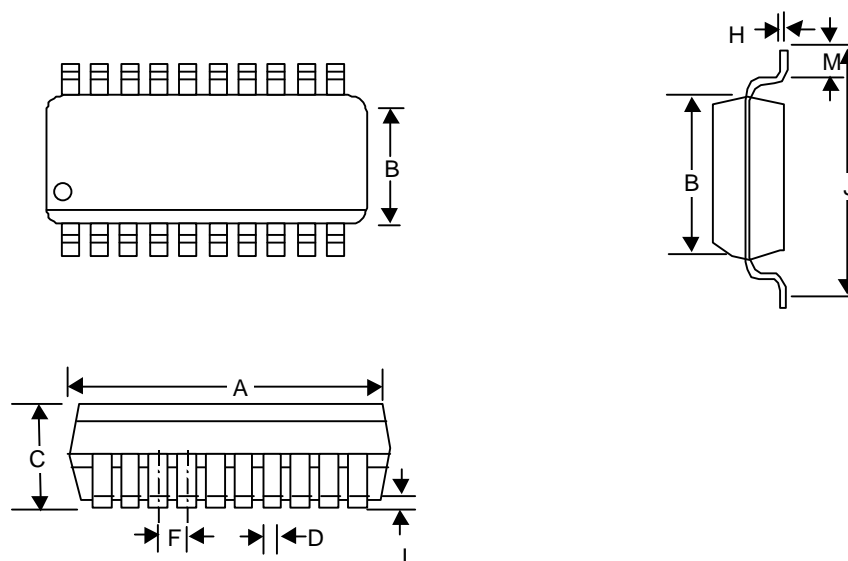

Symbol	Dimensions In Millimeters		Dimensions In Inches	
	Min	Max	Min	Max
A	12.598	13.005	0.496	0.512
B	7.391	7.595	0.291	0.299
C	2.362	2.642	0.093	0.104
D	0.330	0.508	0.013	0.020
F	1.194	1.346	0.047	0.053
H	0.229	0.330	0.009	0.013
I	0.102	0.305	0.004	0.012
J	10.008	10.643	0.394	0.419
M	0.381	1.270	0.015	0.050

RICHTEK TECHNOLOGY CORP.

Headquarter

5F, No. 20, Taiyuen Street, Chupei City

Hsinchu, Taiwan, R.O.C.

Tel: (8863)5526789 Fax: (8863)5526611

RICHTEK TECHNOLOGY CORP.

Taipei Office (Marketing)

8F-1, No. 137, Lane 235, Paochiao Road, Hsintien City

Taipei County, Taiwan, R.O.C.

Tel: (8862)89191466 Fax: (8862)89191465

Email: marketing@richtek.com