

300/500mA Low Dropout Linear Voltage Regulator

General Description

The RT9161/A is a 300/500mA fixed output voltage low dropout linear regulator. Typical ground current is approximately 110µA, from zero to maximum loading conditions. Wide range of available output voltage fits most of applications. Built-in output current-limiting most thermal-limiting provide maximal protection against any fault conditions.

For ease of application, the RT9161/A comes in the popular 3-pin SOT-23(300mA), SOT-89 (300mA), SOT-223 (500mA), or TO-92 packages.

Features

- Low Dropout Voltage of 200mV at Output Current 100mA, 450mV at Output Current 300mA, and 750mV at 500mA Output Current
- Guaranteed 300/500mA Output Current
- Internal 1.5Ω P-MOSFET Draws No Base Current
- Low Ground Current 110µA
- 2% Accuracy Output Voltage
- Input Voltage Range up to 12V
- Extremely Tight Load Regulation
- Fast Transient Response
- Current-limiting and Thermal-limiting

Ordering Information

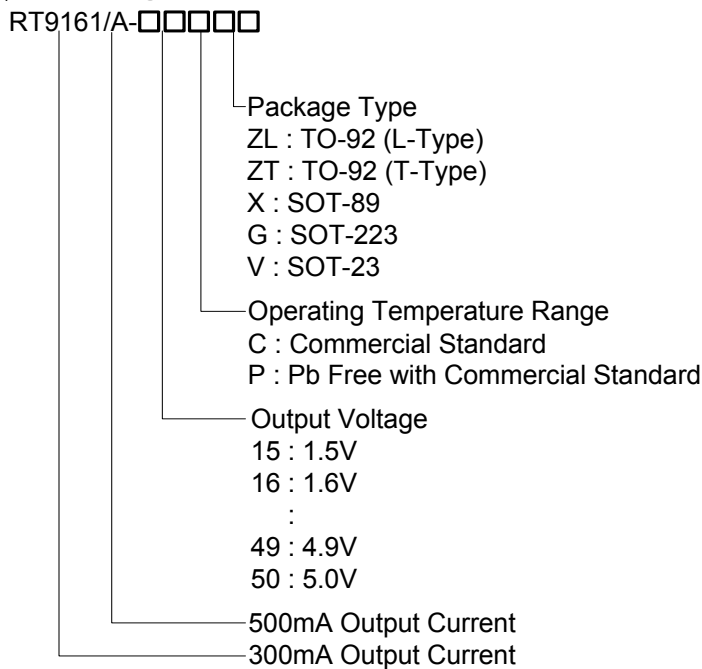

Applications

- Voltage Regulator for LAN Card, CD-ROM, and DVD
- Wireless Communication Systems
- Battery Powered Systems

Pin Configurations

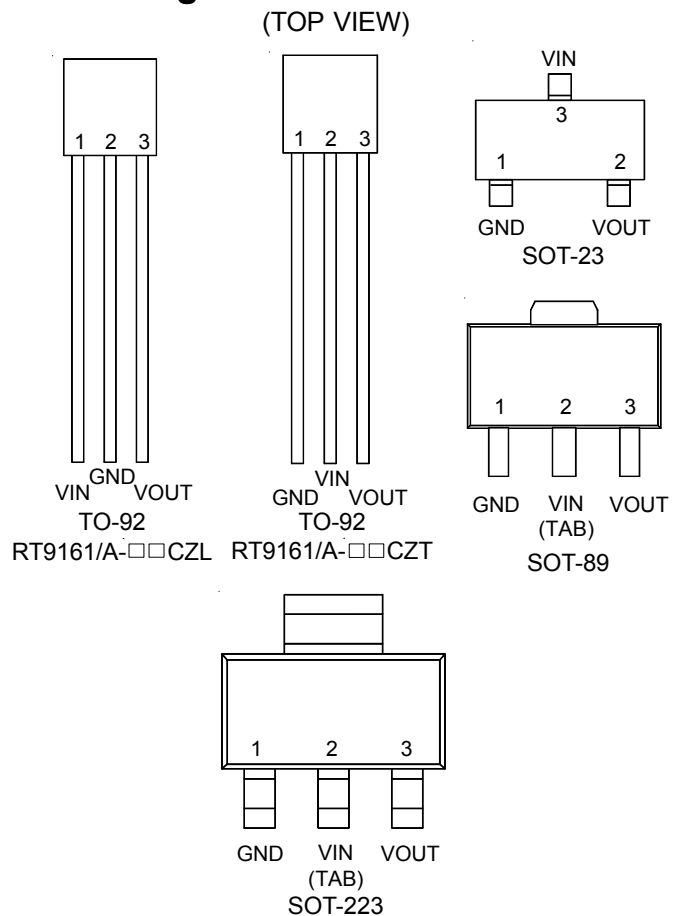

Marking Information

For marking information, contact our sales representative directly or through a RichTek distributor located in your area, otherwise visit our website for detail.

Typical Application Circuit

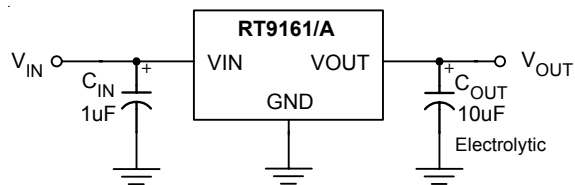

Functional Pin Description

Pin Name	Pin Function
VOUT	Output Voltage
GND	Ground
VIN	Power Input

Function Block Diagram

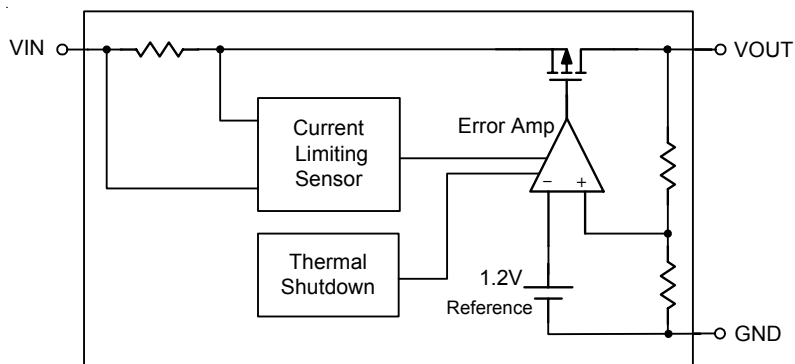

Absolute Maximum Ratings

- Input Voltage ----- -0.3 to 14V
- Operating Junction Temperature Range ----- -40°C to 125°C
- Storage Temperature Range ----- -65°C to 150°C
- Power Dissipation, P_D @ $T_A = 25^\circ\text{C}$
 - SOT-89 ----- 0.5W
 - TO-92 ----- 0.6W
 - SOT-23 ----- 0.15W
- Package Thermal Resistance
 - SOT-89, θ_{JC} ----- 100°C/W
 - SOT-89, θ_{JA} ----- 300°C/W
 - SOT-223, θ_{JC} ----- 15°C/W
 - SOT-223, θ_{JA} ----- 60°C/W
 - TO-92, θ_{JA} ----- 160°C/W
 - SOT-23, θ_{JA} ----- 250°C/W

Electrical Characteristics

($T_A = 25^\circ\text{C}$, $C_{IN} = 1\mu\text{F}$, $C_{OUT} = 10\mu\text{F}$, unless otherwise specified.)

Parameter	Symbol	Test Conditions	Min	Typ	Max	Units	
Output Voltage Accuracy	ΔV_{OUT}	$I_L = 1\text{mA}$, $V_{IN} = 5\text{V}$	-2	--	+2	%	
Output Voltage Temperature Coefficient			--	50	150	PPM/°C	
Line Regulation	ΔV_{LINE}	$I_L = 1\text{mA}$, $V_{IN} = 4.5 \sim 12\text{V}$	--	2	3	% V_{OUT}	
Load Regulation (1)	ΔV_{LOAD}	$I_L = 1\text{mA} \sim 300/500\text{mA}$, $V_{IN} = 5\text{V}$	--	1	30/50	mV	
Current Limit (2)	RT9161	I_{LIMIT}	$V_{IN} = 5\text{V}$, $V_{OUT} = 0\text{V}$	350	580	--	mA
	RT9161A			500	900	--	
Dropout Voltage (3) (4)	V_{DROP}	$I_L = 300/500\text{mA}$	--	450/750	600/1000	mV	
Standby Current	$I_{STANDBY}$	$I_L = 0$, $V_{IN} = 12\text{V}$	--	110	180	μA	

Note:

- (1) Regulation is measured at constant junction temperature, using pulsed ON time.
- (2) Current Limit is measured at constant junction temperature, using pulsed ON time.
- (3) Dropout is measured at constant junction temperature, using pulsed ON time, and the criterion is V_{OUT} inside target value $\pm 2\%$.
- (4) Dropout test is skipped at the condition of $V_{IN} < 3\text{V}$.

Typical Operating Characteristics

Temperature Stability

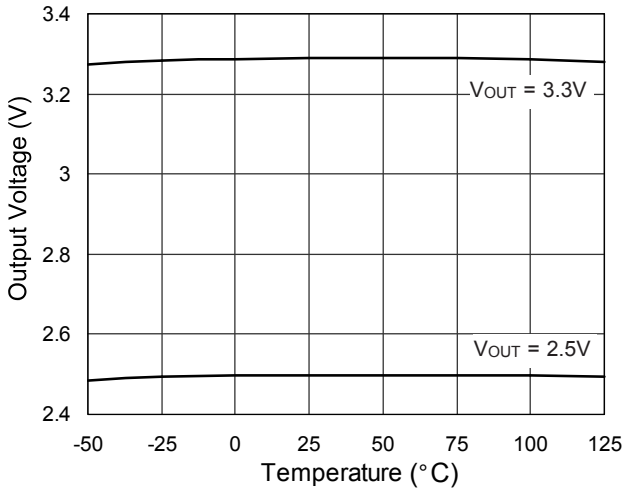

Quiescent Current vs. Temperature

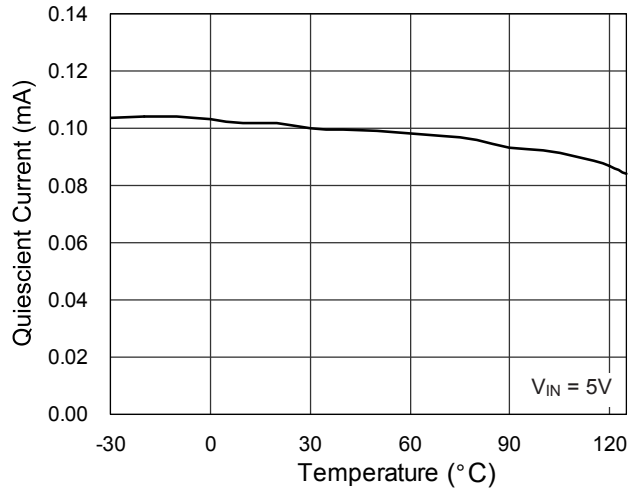

Dropout Voltage ($V_{IN}-V_{OUT}$)

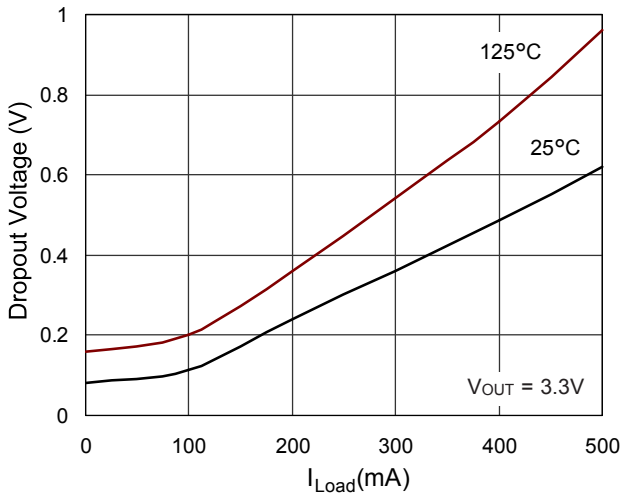

Short Circuit Current

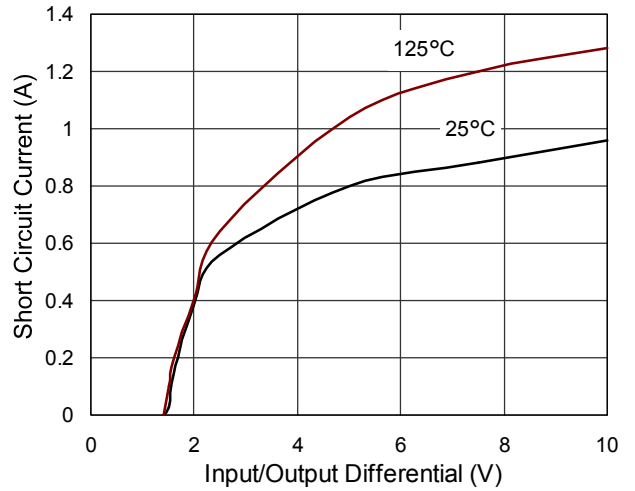

Line Transient Response

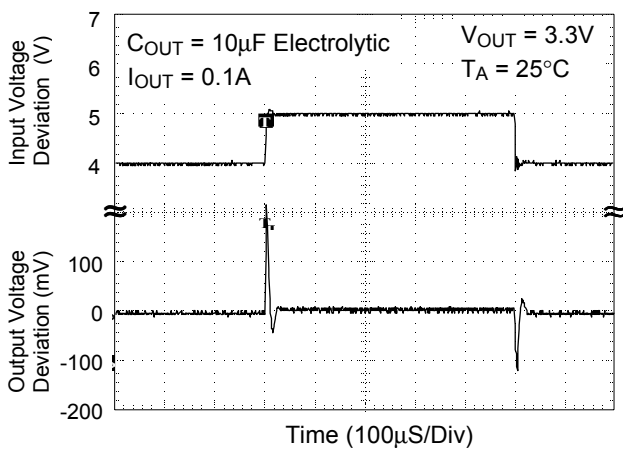

Line Transient Response

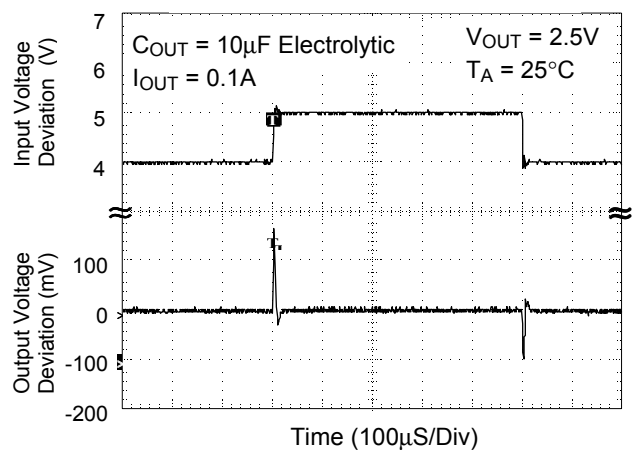

Load Transient Response

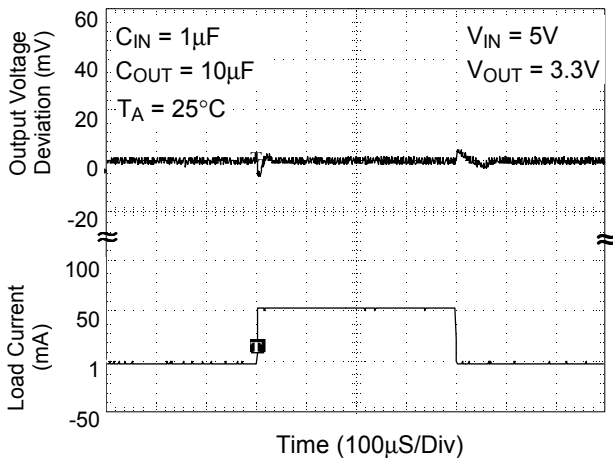

Load Transient Response

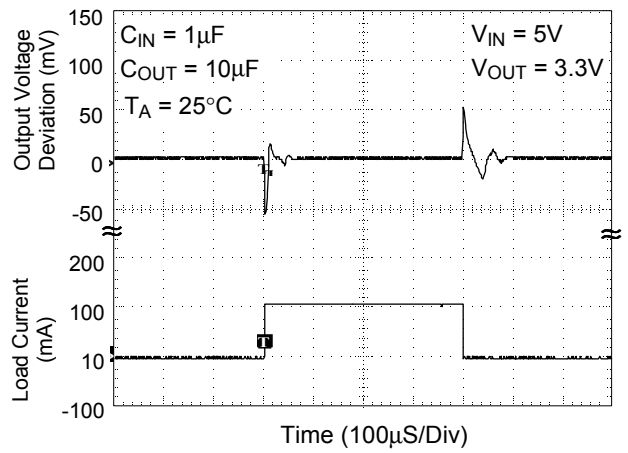

Load Transient Response

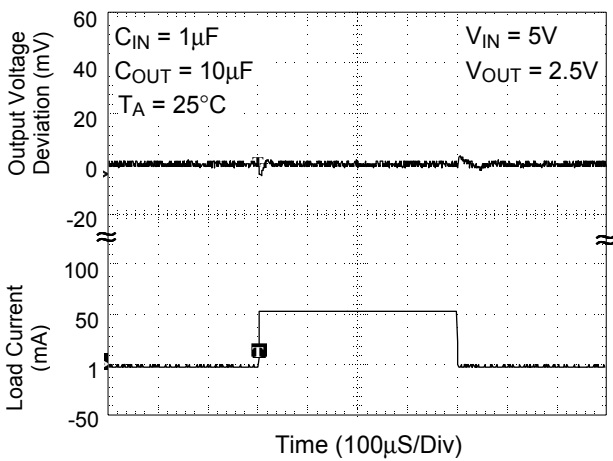

Load Transient Response

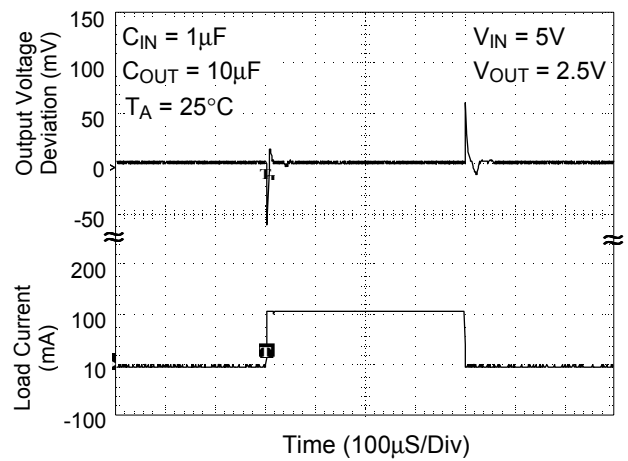

PSRR

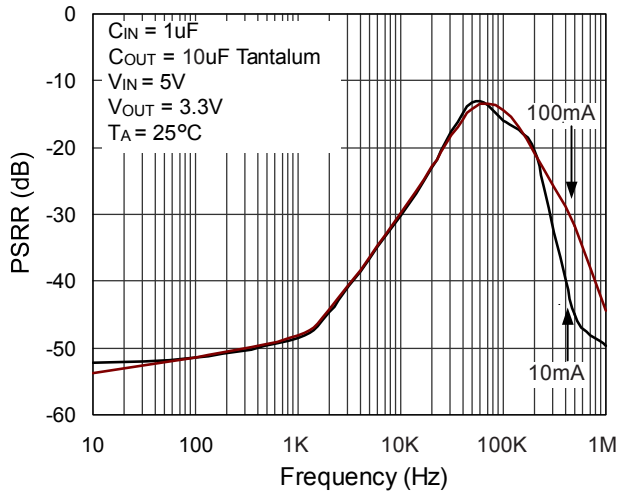

PSRR

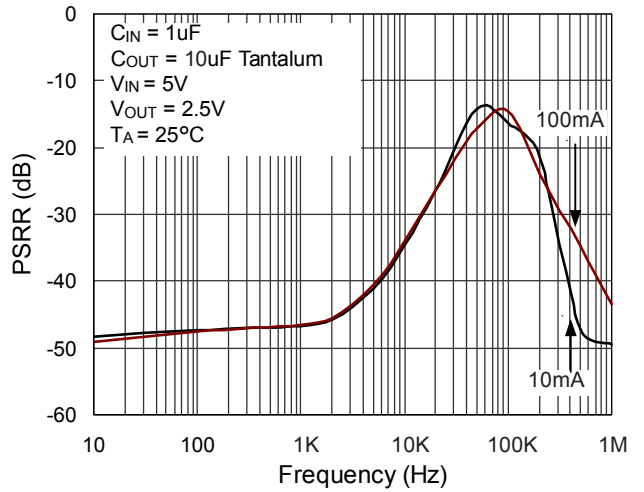

Application Information

A 10 μ F capacitor with 200m Ω or higher ESR, connecting between VOUT and GND pins, is recommended for stability. A capacitor with ESR smaller than 200 m Ω may cause VOUT oscillation as shown in Figure 1. Operating temperature should be well considered to ensure that the capacitance is no less than 10 μ F over the operating temperature range. Please take the notice that Aluminum electrolytic capacitors may cause VOUT oscillation when operating below -25 $^{\circ}$ C. The capacitance can be increased without limit for better transient response.

A 1 μ F or higher capacitor should be placed between VIN and GND to filter out input noise and ensure stable output voltage.

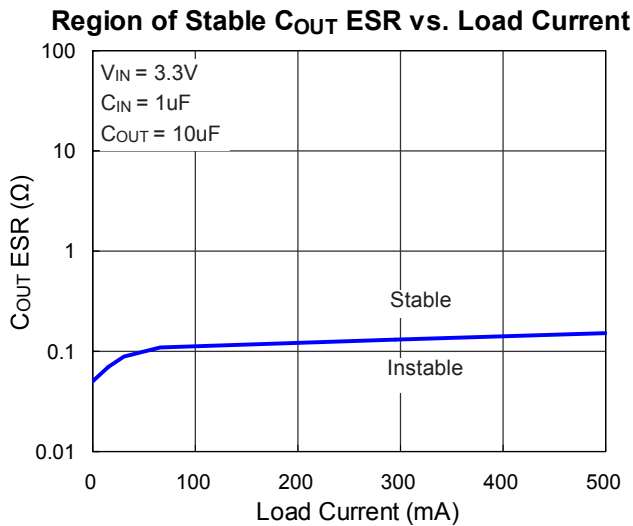
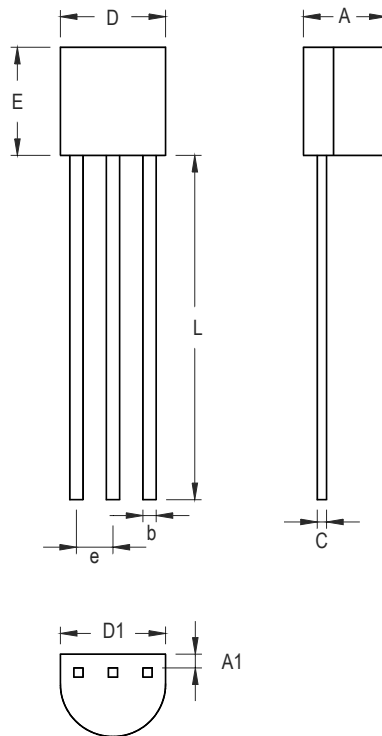

Figure 1

Outline Dimension



Symbol	Dimensions In Millimeters		Dimensions In Inches	
	Min	Max	Min	Max
A	3.175	4.191	0.125	0.165
A1	1.143	1.372	0.045	0.054
b	0.406	0.533	0.016	0.021
C	0.406	0.533	0.016	0.021
D	4.445	5.207	0.175	0.205
D1	3.429	--	0.135	--
E	4.318	5.334	0.170	0.210
e	1.143	1.397	0.045	0.055
L	12.700	--	0.500	--

3-Lead TO-92 Plastic Package

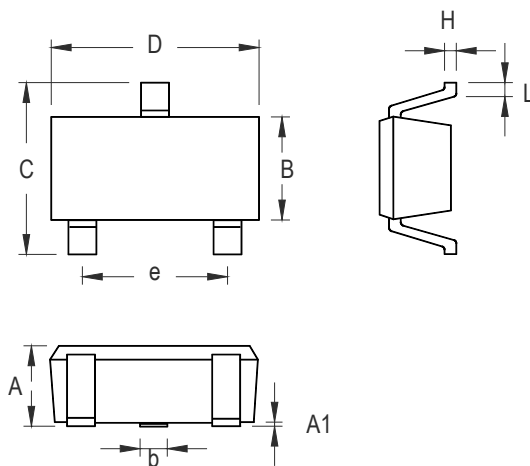

Symbol	Dimensions In Millimeters		Dimensions In Inches	
	Min	Max	Min	Max
A	0.889	1.295	0.035	0.051
A1	0.000	0.152	0.000	0.006
B	1.397	1.803	0.055	0.071
b	0.356	0.508	0.014	0.020
C	2.591	2.997	0.102	0.118
D	2.692	3.099	0.106	0.122
e	1.803	2.007	0.071	0.079
H	0.080	0.254	0.003	0.010
L	0.300	0.610	0.012	0.024

SOT-23 Surface Mount Package

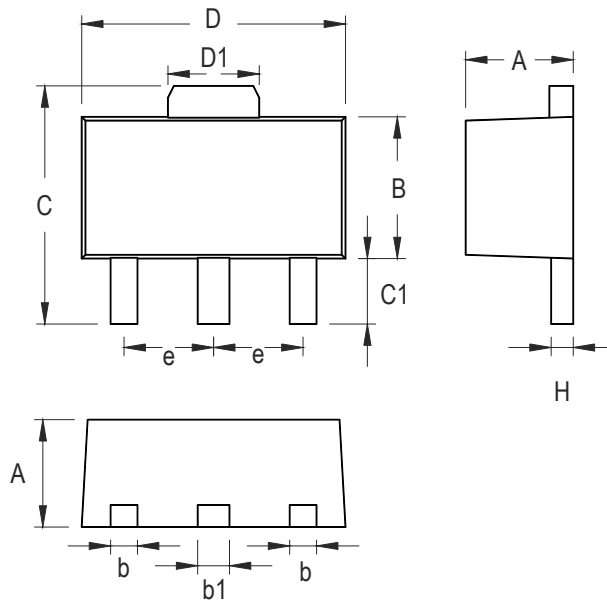

Symbol	Dimensions In Millimeters		Dimensions In Inches	
	Min	Max	Min	Max
A	1.397	1.600	0.055	0.063
b	0.356	0.483	0.014	0.019
B	2.388	2.591	0.094	0.102
b1	0.406	0.533	0.016	0.021
C	--	4.242	--	0.167
C1	0.787	1.194	0.031	0.047
D	4.394	4.597	0.173	0.181
D1	1.397	1.753	0.055	0.069
e	1.448	1.549	0.057	0.061
H	0.355	0.432	0.014	0.017

3-Lead SOT-89 Surface Mount Package

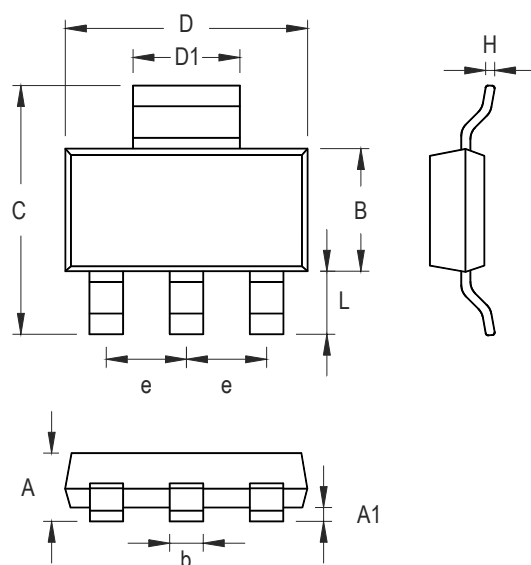

Symbol	Dimensions In Millimeters		Dimensions In Inches	
	Min	Max	Min	Max
A	--	1.803	--	0.071
A1	0.020	0.100	0.0008	0.0047
b	0.610	0.787	0.024	0.031
B	3.302	3.708	0.130	0.146
C	6.706	7.290	0.264	0.287
D	6.299	6.706	0.248	0.264
D1	2.896	3.150	0.114	0.124
e	2.261	2.362	0.089	0.093
H	0.229	0.330	0.009	0.013
L	0.914	--	0.036	--

3-Lead SOT-223 Surface Mount Package