

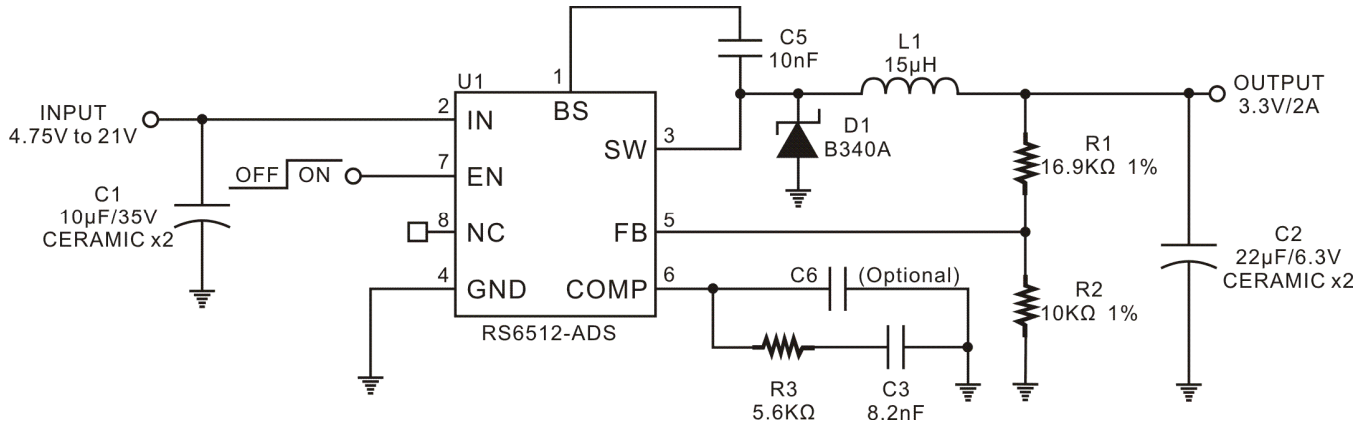

APPLICATION CIRCUIT



ORDER INFORMATION

Device	Device Code
RS6512-XX Y Z	<p>XX is nominal output voltage: AD: ADJ</p> <p>Y is package & Pin Assignments designator: S: SOP-8</p> <p>Z is Lead Free designator: P: Commercial Standard, Lead (Pb) Free and Phosphorous (P) Free Package G: Green (Halogen Free with Commercial Standard)</p>

PIN ASSIGNMENTS

SOP-8

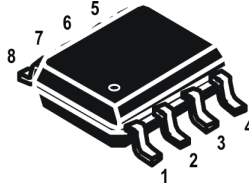

PIN DESCRIPTION

Pin Name	Description	Pin No.
BS	Bootstrap. This capacitor (C5) is needed to drive the power switch's gate above the supply voltage. It is connected between the SW and BS pins to form a floating supply across the power switch driver. The voltage across C5 is about 5V and is supplied by the internal +5V supply when the SW pin voltage is low.	1
IN	Supply Voltage. The RS6512 operates from a 4.75V to 20V unregulated input. C1 is needed to prevent large voltage spikes from appearing at the input.	2
SW	Power Switching Output. SW is the switching node that supplies power to the output. Connect the output LC filter from SW to the output load. Note that a capacitor is required from SW to BS to power the high-side switch.	3
GND	Ground.	4
FB	Feedback Input. FB senses the output voltage and regulates it. Drive FB with a resistive voltage divider from the output voltage to ground. The feedback threshold is 1.23V. See Setting the Output Voltage.	5
COMP	Compensation Node. COMP is used to compensate the regulation control loop. Connect a series RC network from COMP to GND. In some cases, an additional capacitor from COMP to GND is required. See Compensation.	6
EN	Enable Input. EN is a digital input that turns the regulator on or off. Drive EN high to turn on the regulator, drive it low to turn it off. For automatic startup, leave EN unconnected.	7
NC	No internal connection.	8



IMPORTANT NOTICE

Princeton Technology Corporation (PTC) reserves the right to make corrections, modifications, enhancements, improvements, and other changes to its products and to discontinue any product without notice at any time. PTC cannot assume responsibility for use of any circuitry other than circuitry entirely embodied in a PTC product. No circuit patent licenses are implied.

Princeton Technology Corp.
2F, 233-1, Baociao Road,
Sindian Dist, New Taipei 23145, Taiwan
Tel: 886-2-66296288
Fax: 886-2-29174598
<http://www.princeton.com.tw>