

RF142

Heterojunction Bipolar Transistor Power Amplifier Dual-Band Controller for GSM and PCS Applications

The RF142 Power Amplifier (PA) controller is a highly integrated, monolithic device optimized for use in 900 MHz, 1800 MHz, and 1900 MHz Global System For Mobile communications® (GSM®) and other Time Division Multiple Access (TDMA) applications. The control current output from the RF142 can be used to control the transmit power of a dual or multi-band Heterojunction Bipolar Transistor (HBT) PA.

The device consists of two sections: an RF detector, and a gain controller. The RF142, when combined with a PA and a coupler, forms a closed PA control loop, where the PA output power is controlled by a single analog reference voltage, typically supplied by the baseband.

The RF142 device package and pin configuration are shown in Figure 1. The signal pin assignments and functional pin descriptions are specified in Table 1. An RF142 block diagram is shown in Figure 2.

Features

- RF PA controller for use with HBT PAs
- 50 dB detector dynamic range
- Broadband, logarithmic power detector (800 MHz to 2000 MHz)
- Logarithmic RF power detector requires no external diodes
- Integrator and gain shaping block enhance loop stability and linearity
- Three-cell battery operation (2.7 V to 5.0 V)
- Standby mode with 20 μ A of current consumption
- 20-pin Thin Shrink Small Outline Package (TSSOP)

Applications

- Transmit power control for dual or multi-band GSM digital cellular handsets

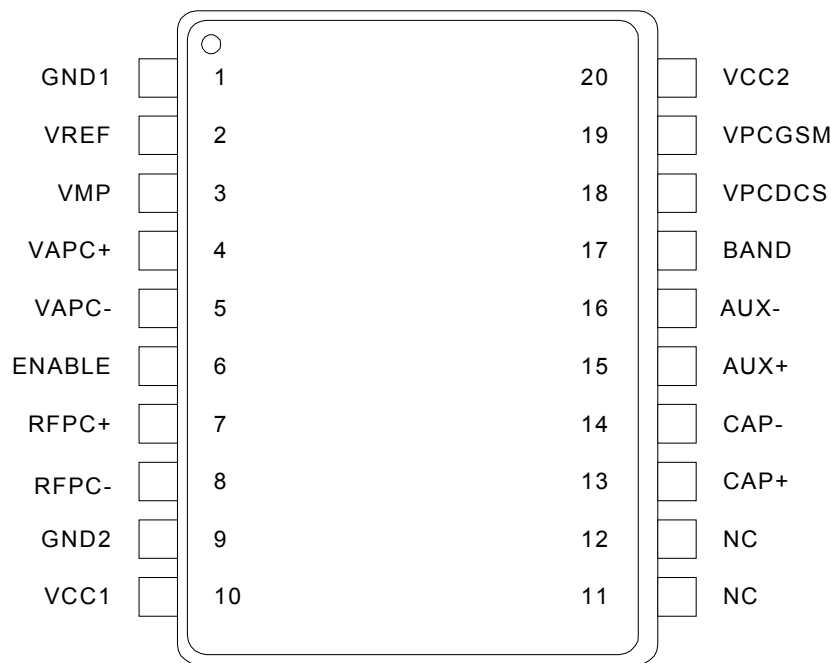

100774A-1_090700

Figure 1. RF142 Pin Configuration – 20-Pin TSSOP

Table 1. RF142 Signal Description

Pin #	Name	Description	Pin #	Name	Description
1	GND1	Ground	11	NC	No connect
2	VREF	Output reference voltage	12	NC	No connect
3	VMP	Midpoint voltage for gain shaper	13	CAP+	Integrator time constant Cap+
4	VAPC+	Tx power control positive polarity	14	CAP-	Integrator time constant Cap-
5	VAPC-	Tx power control negative polarity	15	AUX+	Aux output +
6	ENABLE	Device enable (active high)	16	AUX-	Aux output -
7	RFPC+	RF input to detector positive polarity	17	BAND	Band select. High selects VPCDCS as the output control pin; low selects VPCGSM as the output control pin.
8	RFPC-	RF input to detector negative polarity	18	VPCDCS	1800 MHz/1900 MHz power amplifier control voltage
9	GND2	Ground	19	VPCGSM	900 MHz power amplifier control voltage
10	VCC1	Power supply	20	VCC2	Vcc for the output stage

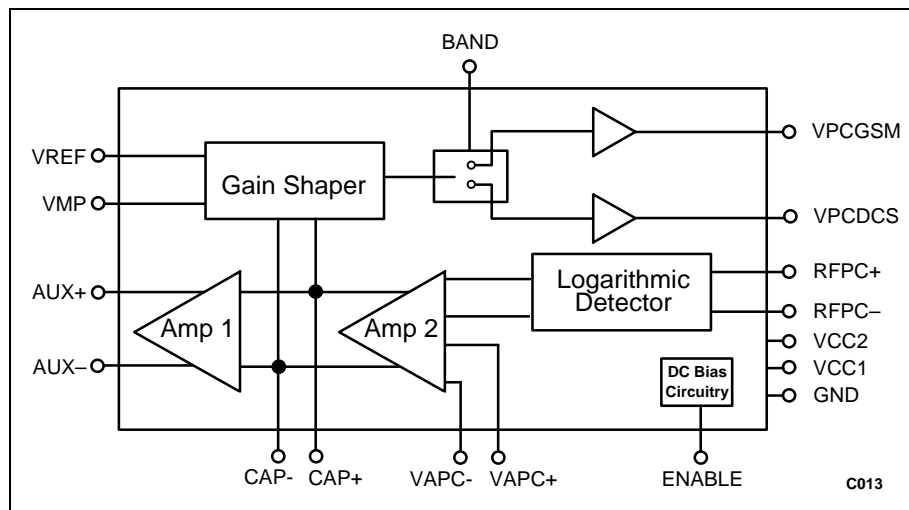

Figure 2. RF142 Block Diagram

Technical Description

The RF142 dual-band PA controller is designed to control HBT PAs. It combines the functions of a broadband RF detector and error amplifier/integrator to provide transmit burst control for dual or multi-band HBT PAs. It has two separate dedicated output stages and pins for GSM900MHz PAs and GSM1800/1900 MHz PAs. The device, when connected to dual or multi-band HBT PAs with a coupler, forms a loop to control the transmit power in a dual or multi-band wireless application. The transmit power is controlled by a single balanced analog reference voltage input to the RF142.

The RF142 has low power consumption and operates off a three-cell battery pack (2.7 V to 5.0 V). Extremely low standby current of 20 μ A maximizes the standby time of a GSM handset.

The absolute maximum ratings of the RF142 are provided in Table 2, the operating conditions are specified in Table 3, and electrical specifications are provided in Table 4. Figure 3 shows

the diagram for a typical application circuit using the RF142 PA controller. Figure 4 shows the package dimensions for the 20-pin TSSOP device and Figure 5 provides the tape and reel dimensions.

RF Detector. An external RF coupler is required at the PA output to couple the RF output from the PA to the RF logarithmic detector input. The input to the logarithmic detector must be within the range -40 dBm to $+10$ dBm. The coupled signal is fed to the input of the RF power detector. The output from the detector is a DC voltage that is proportional to the RF power (in dBm) at the RFPC input to the device. The dynamic range of the detector is 50 dB.

Integrating Error Amplifier. The integrating error amplifier (Amp2) amplifies and integrates the voltage difference between the detector output and the power control input, VAPC. The integrator time constant is set by the two external capacitors connected from AUX pins to the CAP pins.

Gain Shaper. The output of the integrator is fed to the gain shaping circuit that drives the gain control input of the external RF PA. The midpoint voltage of the PA control voltage VPC, is determined by the VMP input. The VMP input is obtained by connecting a resistor divider to the 2.4 V reference output, VREF. The integrator in the integrating error amplifier is used to stabilize the loop.

The maximum voltage obtainable on VPCGSM and VPCDCS is generally 1 V below VCC2 (pin 20). Therefore, it may be more desirable to use a higher voltage than VCC.

Output Stages. Each of the two output stages is dedicated to a frequency band: one for GSM900MHz and one for GSM1800/PCS1900 MHz. The selection of the output stage is determined by the BAND select signal. A high signal selects the VPCDCS as the output pin and a low signal selects VPCGSM

as the output pin. When either output is inactive, its residual output level is extremely low to ensure that the inactive PA is completely off.

DC Bias Block. The DC bias block provides voltage bias to the whole chip, which may be put in standby mode using the ENABLE digital input control pin (pin 6). The ENABLE pin is compatible with TTL levels. When the ENABLE pin is driven high, the device is enabled.

Electro-Static Discharge (ESD) Sensitivity

The RF142 is a static sensitive electronic device. Do not operate or store it near strong electrostatic fields. Take proper ESD precautions.

Table 2. Absolute Maximum Ratings

Parameter	Minimum	Maximum	Units
Storage Temperature	-40	+125	°C
Supply Voltage	-0.3	5.0	V
Power Dissipation	--	500	mW
Input Voltage Range	-0.3	Vcc	V

Table 3. RF142 Recommended Operating Conditions

Parameter	Minimum	Typical	Maximum	Units
Supply Voltage (Vcc)	2.7	3.6	4.8	V
Operating Temperature	-30	+25	+85	°C

Table 4. RF142 Electrical Characteristics (1 of 2)
(TA = 25 °C, Vcc = 3.6 V)

Parameter	Symbol	Test Condition	Min	Typ	Max	Units
Detector frequency range	f		800		2000	MHz
Detector monotonic dynamic range			50			dB
Detector gain				15		mV/dB
Detector stability		Maximum input power and over temperature range. Minimum input power and over temperature range.			±0.5 ±3	dB dB
Detector non-linearity error		RFPC ± from -40 dBm to +8 dBm			± 2	dB
VAPC common mode range				1.35		V
VAPC differential range				±1		Vp-p
VAPC input impedance	ZVAPC			20//5		kΩ//pF
VREF	VREF		2.2	2.4	2.6	V
GSM Maximum Control Voltage	VPCGSM	Band <= 0.8 V Ivpcgsm <= 75 mA	Vcc-1.1	Vcc-1.0	Vcc-0.9	V
DCS Maximum Control Voltage	VPCDCS	Band >= 1.90 V Ivpcdcs <= 50 mA	Vcc-1.1	Vcc-1.0	Vcc-0.9	V

Table 4. RF142 Electrical Characteristics (2 of 2)
(TA = 25 °C, Vcc = 3.6 V)

Parameter	Symbol	Test Condition	Min	Typ	Max	Units
GSM Maximum Sink/Source Control Current	lvpcgsm	BAND <= 0.8 V	90	100	110	mA
DCS Maximum Sink/Source Control Current	lvpcdsc	BAND >= 1.90 V	70	80	90	mA
VPCGSM off voltage		ENABLE = high BAND = low			0.1	V
VPCDCS off voltage		ENABLE = high BAND = high			0.1	V
Control output noise		GSM and DCS			12	nV/√Hz
Error amplifier gain (Note)		Low gain on shaper	35	40	44	dB
Auxiliary amplifier gain			25	28	31	dB
Standby current	ISTDBY	ENABLE = low		20		μA
Supply current	icc	VPCGSM and VPCDCS source current = 0 mA		58	75	mA
BAND and ENABLE VIH	VIH		1.9			V
BAND and ENABLE VIL	VIL				0.8	V

Note. Included Gain Shaper

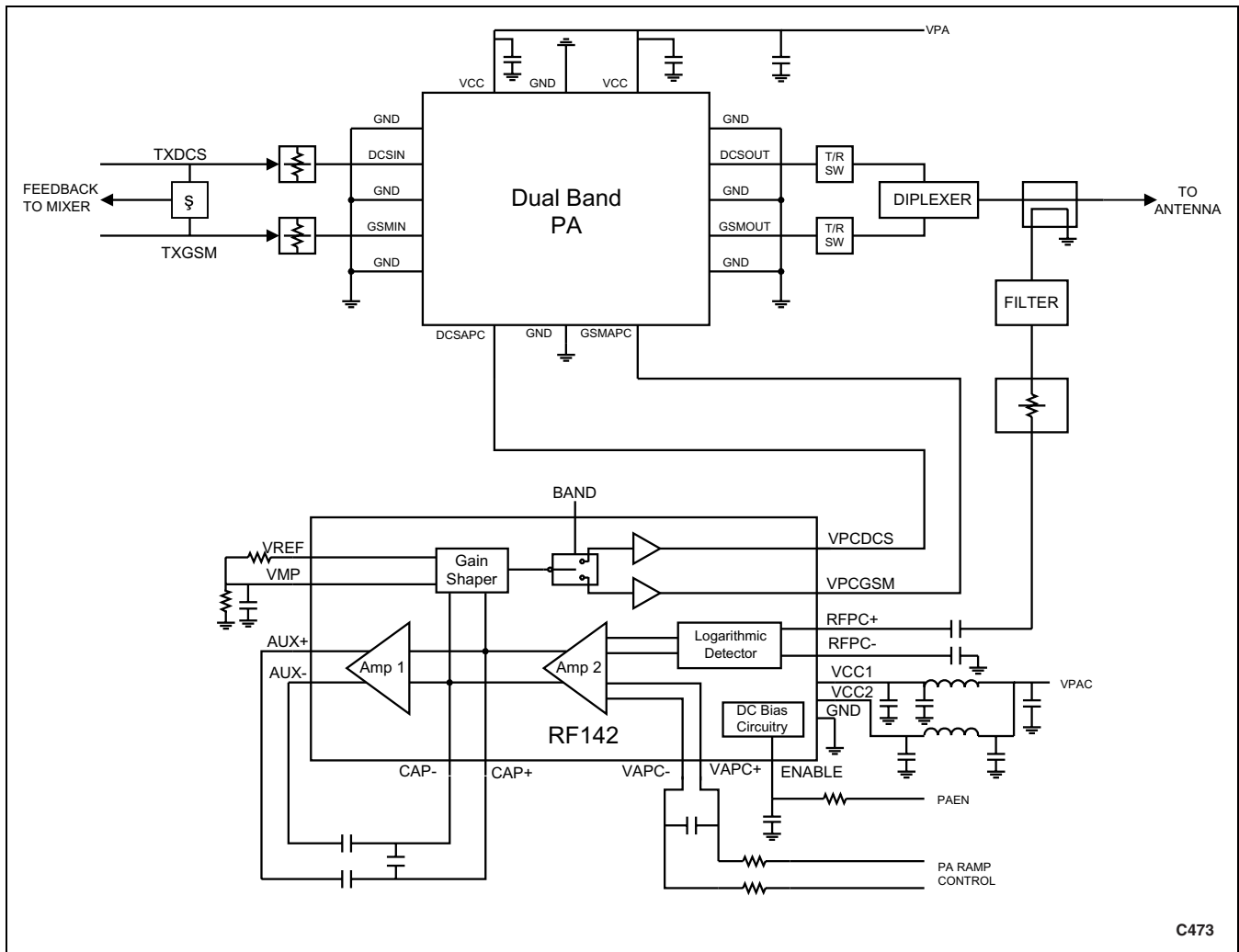

Figure 3. Typical RF142 Application Circuit

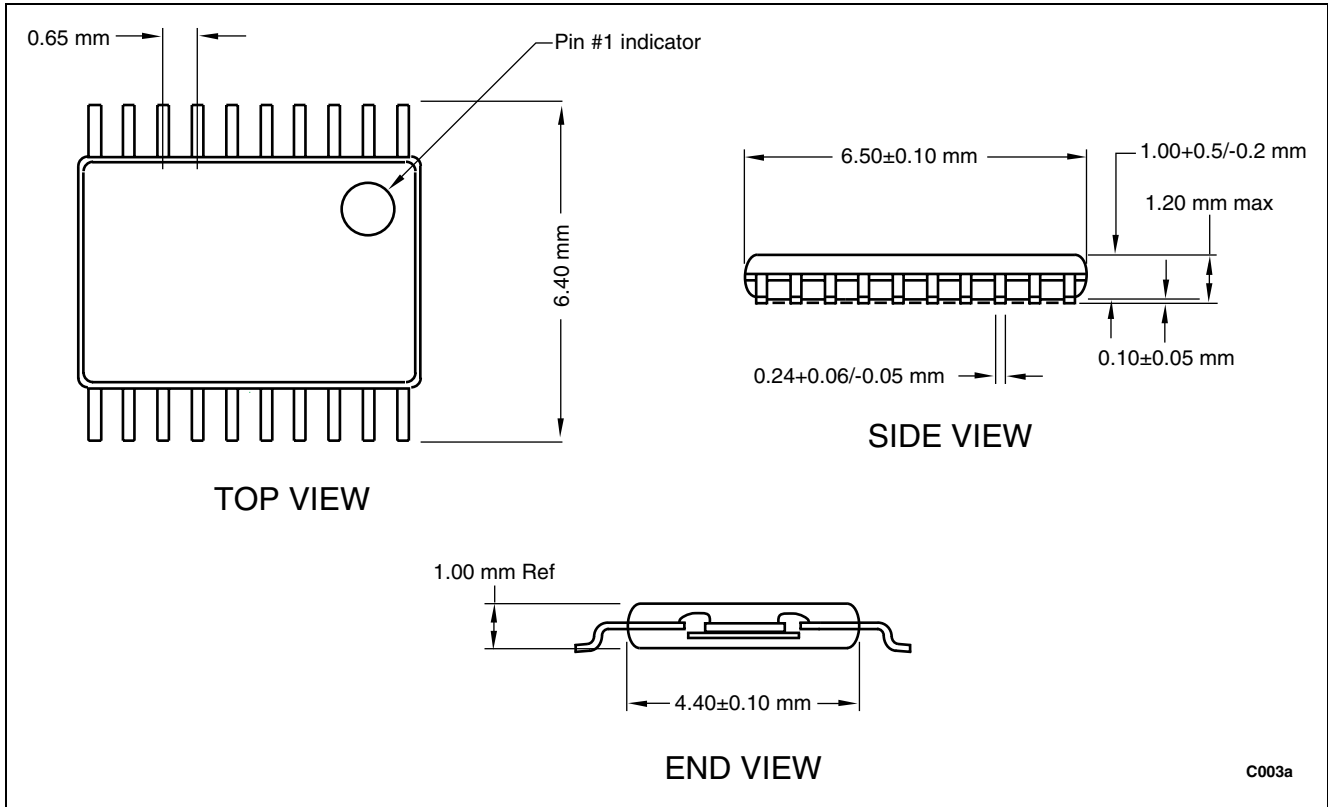

Figure 4. RF142 Package Dimensions – 20-Pin TSSOP

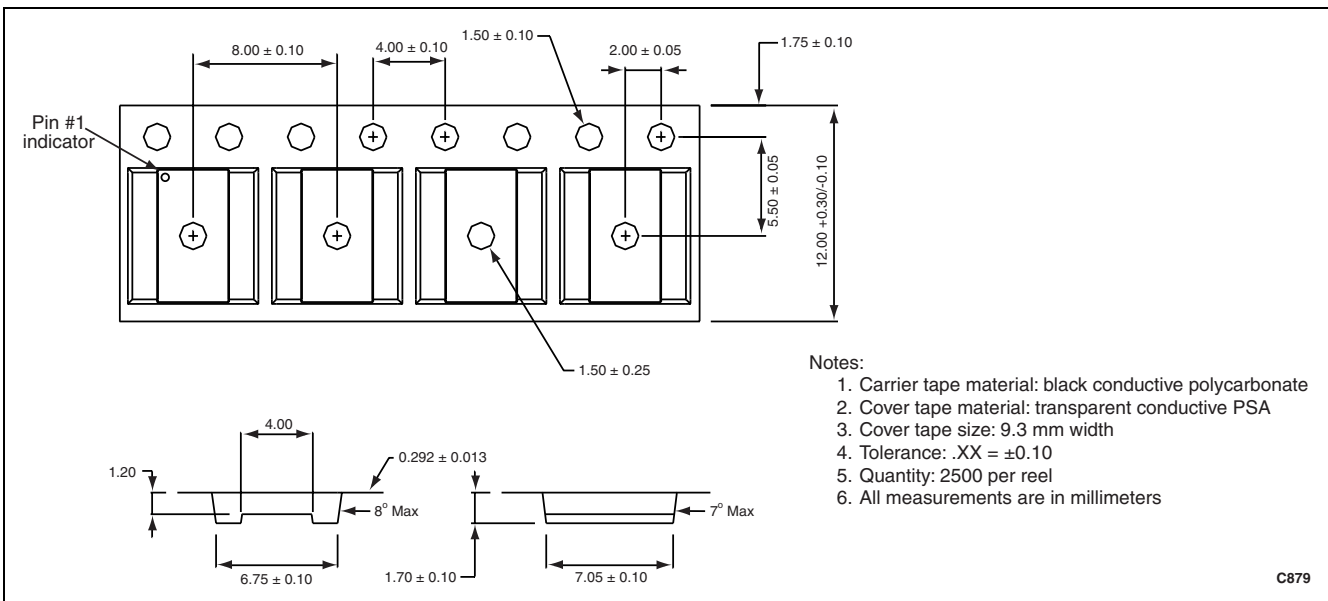

Figure 5. RF142 Tape and Reel Dimensions

Ordering Information

Model Name	Manufacturing Part Number	Product Revision
GSM and PCS PA Controller	RF142	

© 2000, Conexant Systems, Inc.
All Rights Reserved.

Information in this document is provided in connection with Conexant Systems, Inc. ("Conexant") products. These materials are provided by Conexant as a service to its customers and may be used for informational purposes only. Conexant assumes no responsibility for errors or omissions in these materials. Conexant may make changes to specifications and product descriptions at any time, without notice. Conexant makes no commitment to update the information and shall have no responsibility whatsoever for conflicts or incompatibilities arising from future changes to its specifications and product descriptions.

No license, express or implied, by estoppel or otherwise, to any intellectual property rights is granted by this document. Except as provided in Conexant's Terms and Conditions of Sale for such products, Conexant assumes no liability whatsoever.

THESE MATERIALS ARE PROVIDED "AS IS" WITHOUT WARRANTY OF ANY KIND, EITHER EXPRESS OR IMPLIED, RELATING TO SALE AND/OR USE OF CONEXANT PRODUCTS INCLUDING LIABILITY OR WARRANTIES RELATING TO FITNESS FOR A PARTICULAR PURPOSE, CONSEQUENTIAL OR INCIDENTAL DAMAGES, MERCHANTABILITY, OR INFRINGEMENT OF ANY PATENT, COPYRIGHT OR OTHER INTELLECTUAL PROPERTY RIGHT. CONEXANT FURTHER DOES NOT WARRANT THE ACCURACY OR COMPLETENESS OF THE INFORMATION, TEXT, GRAPHICS OR OTHER ITEMS CONTAINED WITHIN THESE MATERIALS. CONEXANT SHALL NOT BE LIABLE FOR ANY SPECIAL, INDIRECT, INCIDENTAL, OR CONSEQUENTIAL DAMAGES, INCLUDING WITHOUT LIMITATION, LOST REVENUES OR LOST PROFITS, WHICH MAY RESULT FROM THE USE OF THESE MATERIALS.

Conexant products are not intended for use in medical, lifesaving or life sustaining applications. Conexant customers using or selling Conexant products for use in such applications do so at their own risk and agree to fully indemnify Conexant for any damages resulting from such improper use or sale.

The following are trademarks of Conexant Systems, Inc.: Conexant™, the Conexant C symbol, and "What's Next in Communications Technologies"™. Product names or services listed in this publication are for identification purposes only, and may be trademarks of third parties. Third-party brands and names are the property of their respective owners.

For additional disclaimer information, please consult Conexant's Legal Information posted at www.conexant.com, which is incorporated by reference.

Reader Response: Conexant strives to produce quality documentation and welcomes your feedback. Please send comments and suggestions to conexant.tech.pubs@conexant.com. For technical questions, contact your local Conexant sales office or field applications engineer.



Further Information
literature@conexant.com
(800) 854-8099 (North America)
(949) 483-6996 (International)
Printed in USA

World Headquarters
Conexant Systems, Inc.
4311 Jamboree Road
Newport Beach, CA
92660-3007

Phone: (949) 483-4600
Fax 1: (949) 483-4078
Fax 2: (949) 483-4391

Americas

U.S. Northwest/
Pacific Northwest – Santa Clara
Phone: (408) 551-0270
Fax: (408) 249-7113

U.S. Southwest – Los Angeles
Phone: (949) 483-9119
Fax: (949) 483-9090

U.S. Southwest – Orange County
Phone: (949) 483-9119
Fax: (949) 483-9090

U.S. Southwest – San Diego
Phone: (858) 713-3374
Fax: (858) 713-4001

U.S. North Central – Illinois
Phone: (630) 773-3454
Fax: (630) 773-3907

U.S. South Central – Texas
Phone: (972) 733-0723
Fax: (972) 407-0639

U.S. Northeast – Massachusetts
Phone: (978) 367-3200
Fax: (978) 256-6868

U.S. Southeast – North Carolina
Phone: (919) 858-9110
Fax: (919) 858-8669

U.S. Southeast – Florida/
South America
Phone: (727) 799-8406
Fax: (727) 799-8306

U.S. Mid-Atlantic – Pennsylvania
Phone: (215) 244-6784
Fax: (215) 244-9292

Canada – Ontario
Phone: (613) 271-2358
Fax: (613) 271-2359

Europe

Europe Central – Germany
Phone: +49 89 829-1320
Fax: +49 89 834-2734

Europe North – England
Phone: +44 (0)118 920 9500
Fax: +44 (0)118 920 9595

Europe – Israel/Greece
Phone: +972 9 9524000
Fax: +972 9 9573732

Europe South – France
Phone: +33 1 41 44 36 51
Fax: +33 1 41 44 36 90

Europe Mediterranean – Italy
Phone: +39 02 93179911
Fax: +39 02 93179913

Europe – Sweden
Phone: +46 (0) 8 5091 4319
Fax: +46 (0) 8 590 041 10

Europe – Finland
Phone: +358 (0) 9 85 666 435
Fax: +358 (0) 9 85 666 220

Asia – Pacific

Taiwan
Phone: (886-2) 2-720-0282
Fax: (886-2) 2-757-6760

Australia
Phone: (613) 9583 2650
Fax: (613) 9583 9453

China – Central
Phone: 86-21-6361-2515
Fax: 86-21-6361-2516

China – South
Phone: (852) 2 827-0181
Fax: (852) 2 827-6488

China – South (Satellite)
Phone: (86) 755-518-2495

China – North
Phone: (86-10) 8529-9777
Fax: (86-10) 8529-9778

India
Phone: (91-11) 692-4789
Fax: (91-11) 692-4712

Korea
Phone: (82-2) 565-2880
Fax: (82-2) 565-1440

Korea (Satellite)
Phone: (82-53) 745-2880
Fax: (82-53) 745-1440

Singapore
Phone: (65) 737 7355
Fax: (65) 737 9077

Japan
Phone: (81-3) 5371 1520
Fax: (81-3) 5371 1501

www.conexant.com