

# DATA SHEET

## **PCA146x series** 32 kHz watch circuits with adaptive motor pulse

Product specification  
Supersedes data of 1998 Mar 18  
File under Integrated Circuits, IC16

1998 Apr 21

## 32 kHz watch circuits with adaptive motor pulse

## PCA146x series

### FEATURES

- 32 kHz oscillator, amplitude regulated with excellent frequency stability
- High immunity of the oscillator to leakage currents
- Time calibration electrically programmable and reprogrammable (via EEPROM)
- A quartz crystal is the only external component required
- Very low current consumption; typically 170 nA
- Output for bipolar stepping motors of different types
- Up to 50% reduction in motor current compared with conventional circuits, by self adaption of the motor pulse width to match the required torque of the motor
- No loss of motor steps possible because of on-chip detection of the induced motor voltage
- Detector for lithium or silver-oxide battery voltage levels
- Indication for battery end-of-life
- Stop function for accurate timing
- Power-on reset for fast testing
- Various test modes for testing the mechanical parts of the watch and the IC.

### GENERAL DESCRIPTION

The PCA146x series devices are CMOS integrated circuits specially suited for battery-operated, quartz-crystal-controlled wrist-watches, with a bipolar stepping motor.

### ORDERING INFORMATION

| TYPE NUMBER | PACKAGE <sup>(1)</sup> |                         |         |
|-------------|------------------------|-------------------------|---------|
|             | NAME                   | DESCRIPTION             | VERSION |
| PCA1461U    | –                      | chip in tray            | –       |
| PCA1461U/10 | –                      | chip on foil            | –       |
| PCA1462U    | –                      | chip in tray            | –       |
| PCA1462U/7  | –                      | chip with bumps on tape | –       |
| PCA1462U/10 | –                      | chip on foil            | –       |
| PCA1463U    | –                      | chip in tray            | –       |
| PCA1463U/10 | –                      | chip on foil            | –       |
| PCA1465U/10 | –                      | chip on foil            | –       |
| PCA1465U/7  | –                      | chip with bumps on tape | –       |
| PCA1467U/10 | –                      | chip on foil            | –       |

#### Note

1. Figure 1 and Chapter "Package outline" show details of standard package, available for large orders only. Chapter "Chip dimensions and bonding pad locations" shows exact pad locations for other delivery formats.

32 kHz watch circuits with adaptive motor pulse

PCA146x series

PINNING

| SYMBOL          | PIN | DESCRIPTION       |
|-----------------|-----|-------------------|
| V <sub>SS</sub> | 1   | ground (0 V)      |
| TEST            | 2   | test output       |
| OSC IN          | 3   | oscillator input  |
| OSC OUT         | 4   | oscillator output |
| V <sub>DD</sub> | 5   | supply voltage    |
| M1              | 6   | motor 1 output    |
| M2              | 7   | motor 2 output    |
| RESET           | 8   | reset input       |

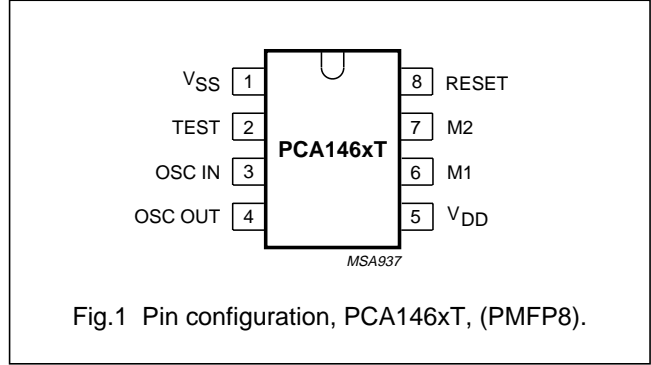

Fig.1 Pin configuration, PCA146xT, (PMFP8).

FUNCTIONAL DESCRIPTION AND TESTING

The motor output delivers pulses of six different stages depending on the torque required to turn the motor (Figs. 3 and 4). Every motor pulse is followed by a detection phase which monitors the waveform of the induced motor voltage. When a step is missed a correction sequence will be started (Fig.2).

Motor pulses

The circuit produces motor pulses of six different stages (stage 1 to 5, stage 8). Each stage has two independent modes: silver-oxide and lithium. The voltage level of V<sub>DD</sub> determines which mode is selected (see Section "Voltage level detector").

Stages 1 to 5 (both modes) are used in normal operation, stage 8 occurs under the following conditions:

- Correction pulse after a missing step (both modes)
- End-of-life mode
- If stage 5 is not enough to turn the motor (both modes).

In the silver-oxide mode, the ON state of the motor pulse varies between 56.25% and 100% of the duty factor  $t_{DF} = 977 \mu s$  depending on the stage (Fig.3). It increases in steps of 6.25% per stage.

In the lithium mode, the ON state of the motor pulse is reduced by 18.75% of the duty factor  $t_{DF}$  (Fig.4) to compensate for the increase in the voltage level.

After a RESET the circuit always starts and continues with stage 1, when all motor pulses have been executed. A failure to execute all motor pulses results in the circuit going into stage 2, this sequence will be repeated through to stage 8.

When the motor pulses at stage 5 are not large enough to turn the motor, stage 8 is implemented for a maximum of 8 minutes with no attempt to keep current consumption low. After stage 8 has been executed the procedure is repeated from RESET.

The circuit operates for 8 minutes at a fixed stage, if every motor pulse is executed. The next 480 motor pulses are then produced at the next lower stage unless a missing step is detected. If a step is missed a correction sequence is produced and for a maximum of 8 minutes the motor pulses are increased by one stage.

# 32 kHz watch circuits with adaptive motor pulse

## PCA146x series

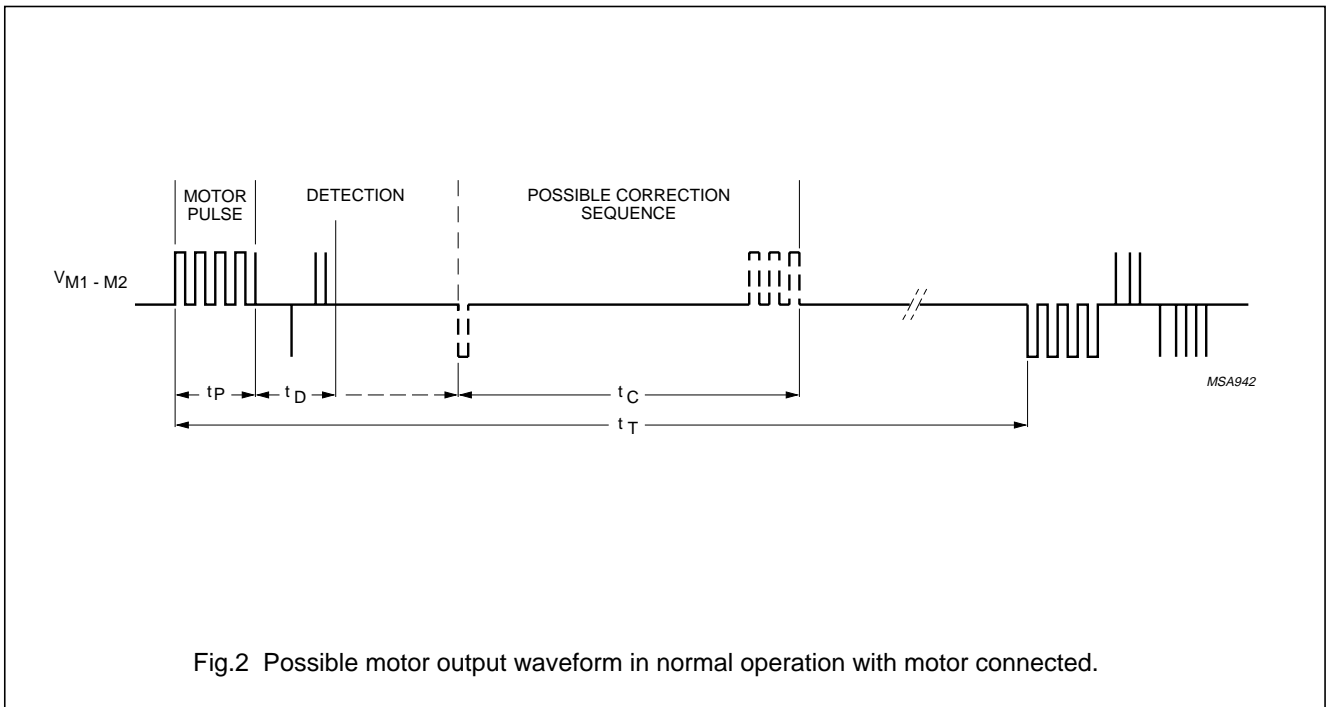
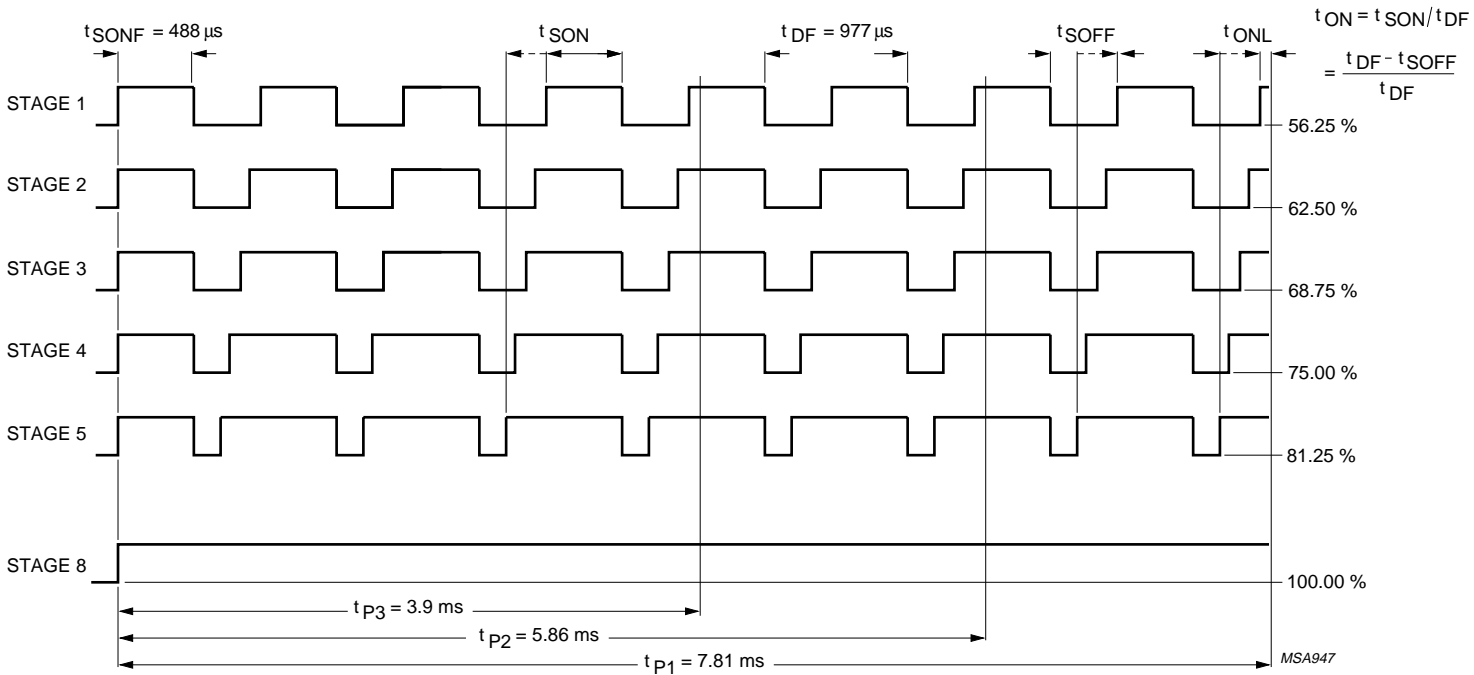

Fig.2 Possible motor output waveform in normal operation with motor connected.

32 kHz watch circuits with adaptive motor pulse

PCA146x series



$t_{OFF}$  for stage 1 to 5 =  $488 \mu s - \text{stage} \times 61 \mu s$   
 $t_{ON}$  for stage 1 to 5 =  $488 \mu s + \text{stage} \times 61 \mu s$

Fig.3 Motor pulses in the silver-oxide mode ( $V_{DD} = 1.55 \text{ V}$ ).

32 KHz watch circuits with adaptive motor pulse

PCA146x series

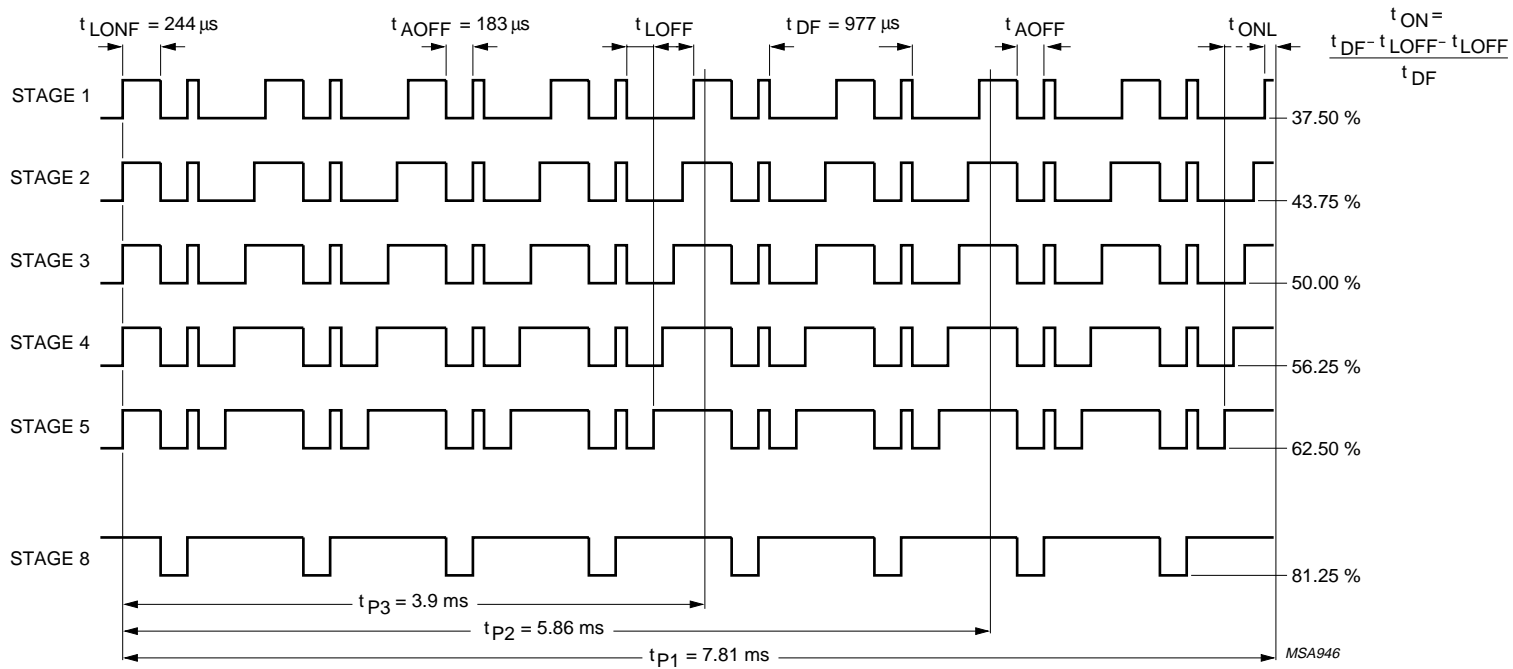

$t_{OFF}$  for stage 1 to 5 =  $672 \mu s - \text{stage} \times 61 \mu s$   
 $t_{ON}$  for stage 1 to 5 =  $305 \mu s + \text{stage} \times 61 \mu s$

Fig.4 Motor pulses in the lithium mode ( $V_{DD} = 2.1 \text{ V}$ ).

# 32 kHz watch circuits with adaptive motor pulse

## PCA146x series

### Voltage level detector

The supply voltage is compared with the internal voltage reference  $V_{LIT}$  and  $V_{EOL}$  every minute. The first voltage level detection is carried out 30 ms after RESET.

When a lithium voltage level is detected ( $V_{DD} \geq V_{LIT}$ ), the circuit starts operating in the lithium mode (Fig.4).

When the detected  $V_{DD}$  voltage level is between  $V_{LIT}$  and  $V_{EOL}$ , the circuit operates in the silver-oxide mode (Fig.3).

If the battery end-of-life is detected ( $V_{DD} < V_{EOL}$ ), the detection and stage control is switched OFF and the waveform produced is an unchopped version of the stage 8 waveform. To indicate this condition the waveform is produced in bursts of 4 pulses every 4 s.

### Detection of motor movement

After a motor pulse, the motor is short-circuited to  $V_{DD}$  for 1 ms. Afterwards the energy in the motor inductor will be dissipated to measure only the current generated by the induced motor voltage. During the time  $t_{DI}$  (dissipation of energy time) all switches shown in Fig.5 are open to reduce the current as fast as possible. The current will now flow through the diodes D3 and D2, or D4 and D1. Then the first of 52 possible measurement cycles ( $t_{MC}$ ) starts to measure the induced current.

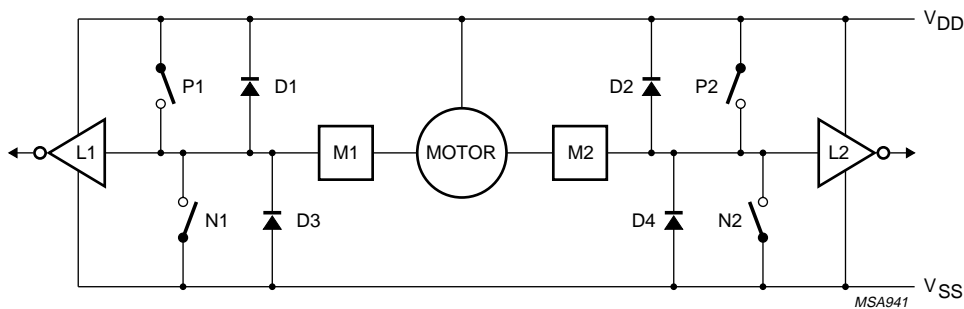

Fig.5 Motor driving and detecting circuit.

## 32 kHz watch circuits with adaptive motor pulse

## PCA146x series

### Detection criteria

The PCA146x uses current detection in two defined parts of the detection phase to determine if the motor has moved (refer to Figs 6 and 7). The detection criteria are:

#### part 1

- Minimum value of  $P = 1$ ; where  $P$  = number of measured positive current polarities after  $t_{D1}$ .

#### part 2

- Minimum value of  $N = 2$ ; where  $N$  = number of measured positive current polarities since the first negative current polarity after part 1 was detected (see Fig.6).

If the opposite polarity is measured in one part, the internal counter is reset, so the results of all measurements in this part are ignored.

The waveform of the induced current must enable all these measurements within the time  $t_D$  after the end of a positive motor pulse in order to be accepted as a waveform of an executed motor pulse.

If the detection criterion is satisfied earlier, a measurement cycle will not be started and the switches P1 and P2 stay closed, the motor is switched to  $V_{DD}$ .

Every measurement cycle ( $t_{MC}$ ) has 4 phases. These are detailed in Table 1.

Note that detection and pulse width control will be switched OFF when the battery voltage is below the end-of-life voltage ( $V_{EOL}$ ), or if stage 5 is not sufficient to turn the motor.

**Table 1** Measurement cycle

| SYMBOL   | PHASE | DESCRIPTION                                                                                                                                                                                                                                                                                                                                                                                                                                                                                                                                                                                                                                                                                                                                                                                           |
|----------|-------|-------------------------------------------------------------------------------------------------------------------------------------------------------------------------------------------------------------------------------------------------------------------------------------------------------------------------------------------------------------------------------------------------------------------------------------------------------------------------------------------------------------------------------------------------------------------------------------------------------------------------------------------------------------------------------------------------------------------------------------------------------------------------------------------------------|
| $t_{M1}$ | 1     | During $t_{M1}$ the switches P1 and P2 are closed in order to switch the motor to $V_{DD}$ , so the induced current flows unaffected through the motor inductance.                                                                                                                                                                                                                                                                                                                                                                                                                                                                                                                                                                                                                                    |
| $t_{M2}$ | 2     | Measures the induced current; during a maximum time $t_{M2}$ all switches are open until a change is sensed by one of the level detectors (L1, L2). The motor is short-circuited to $V_{DD}$ .<br>Depending on the direction of the interrupted current: <ul style="list-style-type: none"> <li>• The current flows through diodes D3 and D2, causing the voltage at M1 to decrease in relation to M2;</li> <li>• The current flows through diodes D4 and D1, causing the voltage at M2 to decrease in relation to M1.</li> </ul> A successfully detected current polarity is normally characterized by a short pulse of 0.5 to 10 $\mu\text{s}$ with a voltage up to $\pm 2.1$ V, failed polarity detection by the maximum pulse width of 61 $\mu\text{s}$ and a voltage of $\pm 0.5$ V (see Fig.7). |
| $t_{M3}$ | 3     | The switches P1 and P2 remain closed for the time $t_{M3}$ .                                                                                                                                                                                                                                                                                                                                                                                                                                                                                                                                                                                                                                                                                                                                          |
| $t_{M4}$ | 4     | If the circuit detects fewer pulses than $P$ and $N$ respectively, a pulse of the time $t_{M4}$ occurs to reduce the induced current. Therefore P2 and P1 are opened and N1 and N2 are closed. Otherwise P1 and P2 remain closed.                                                                                                                                                                                                                                                                                                                                                                                                                                                                                                                                                                     |



32 kHz watch circuits with adaptive motor pulse

PCA146x series

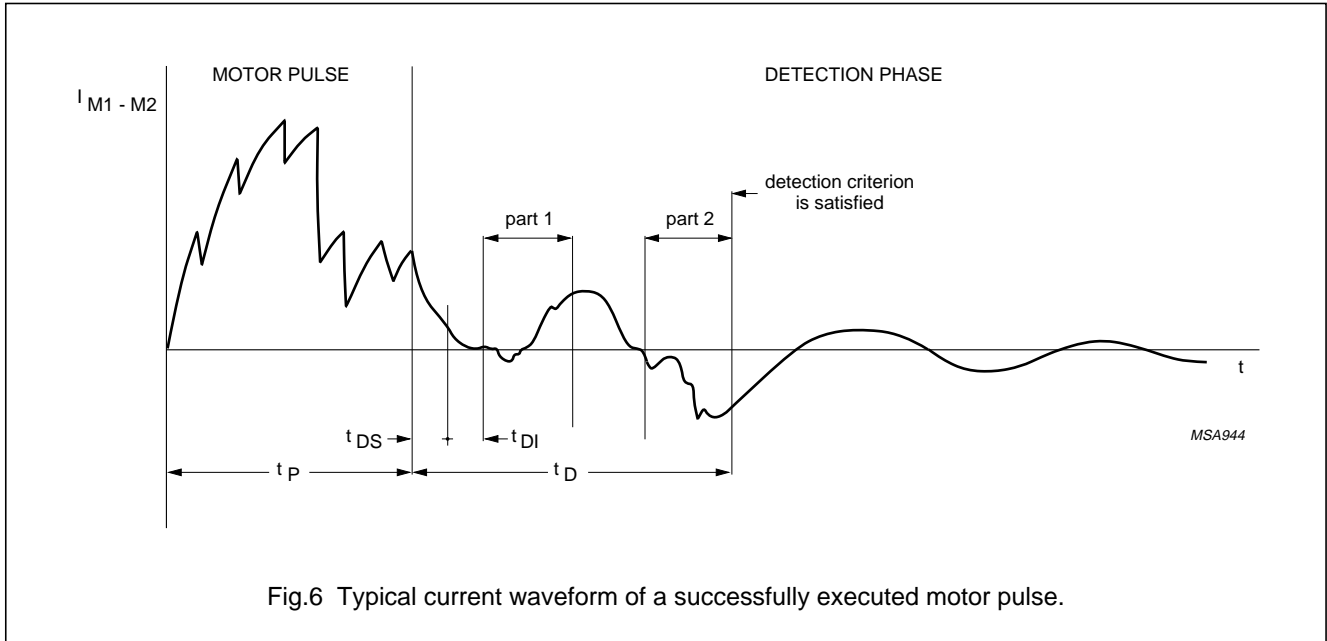

Fig.6 Typical current waveform of a successfully executed motor pulse.

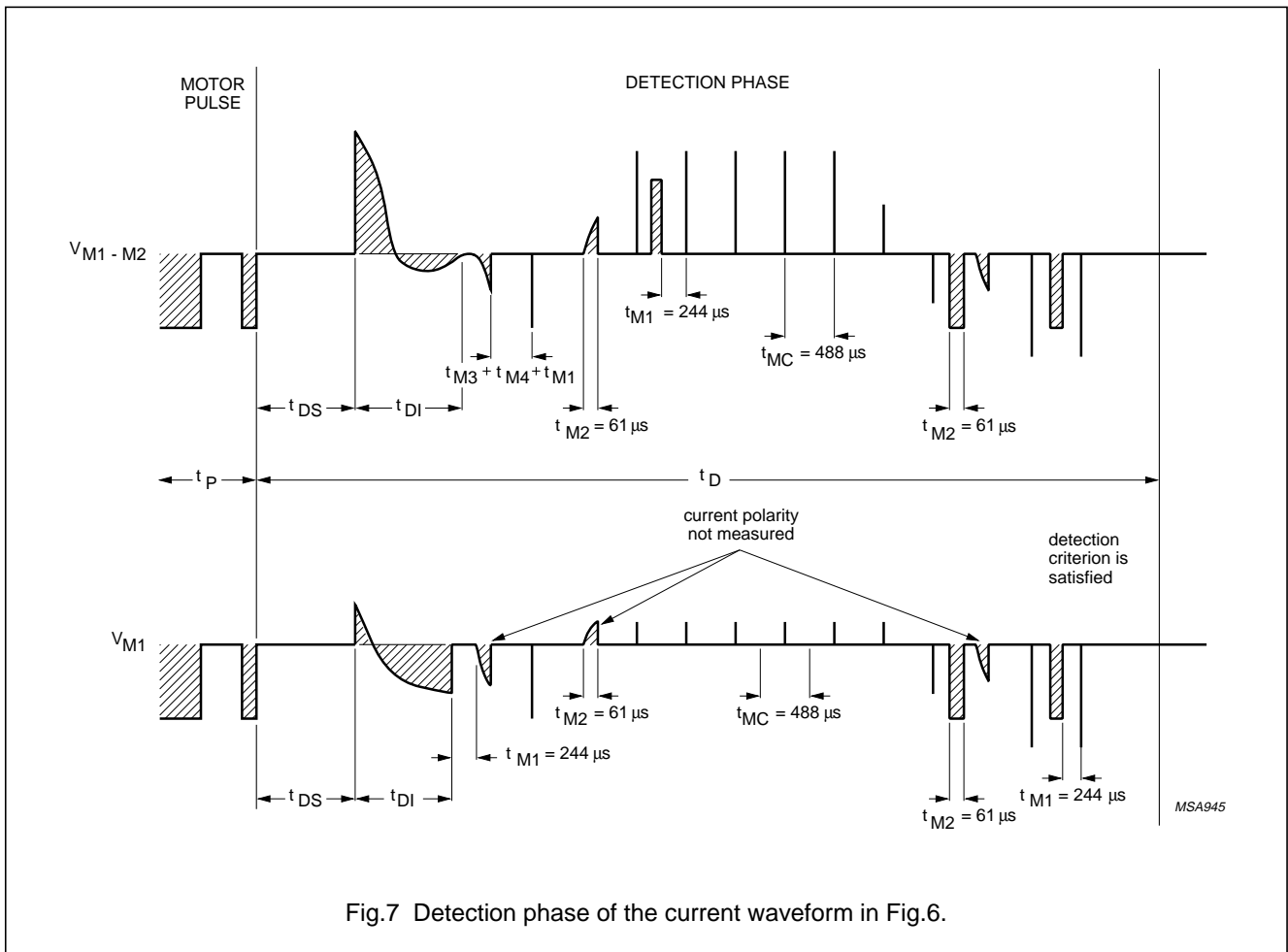

Fig.7 Detection phase of the current waveform in Fig.6.

# 32 kHz watch circuits with adaptive motor pulse

## PCA146x series

### Correction sequence (see Fig.8)

If a missing step is detected, a correction sequence is produced. This consists of a small pulse ( $t_{C1}$ ) which gives the motor a defined position and after 29.30 ms a pulse of stage 8 ( $t_{C2}$ ) to turn the motor.

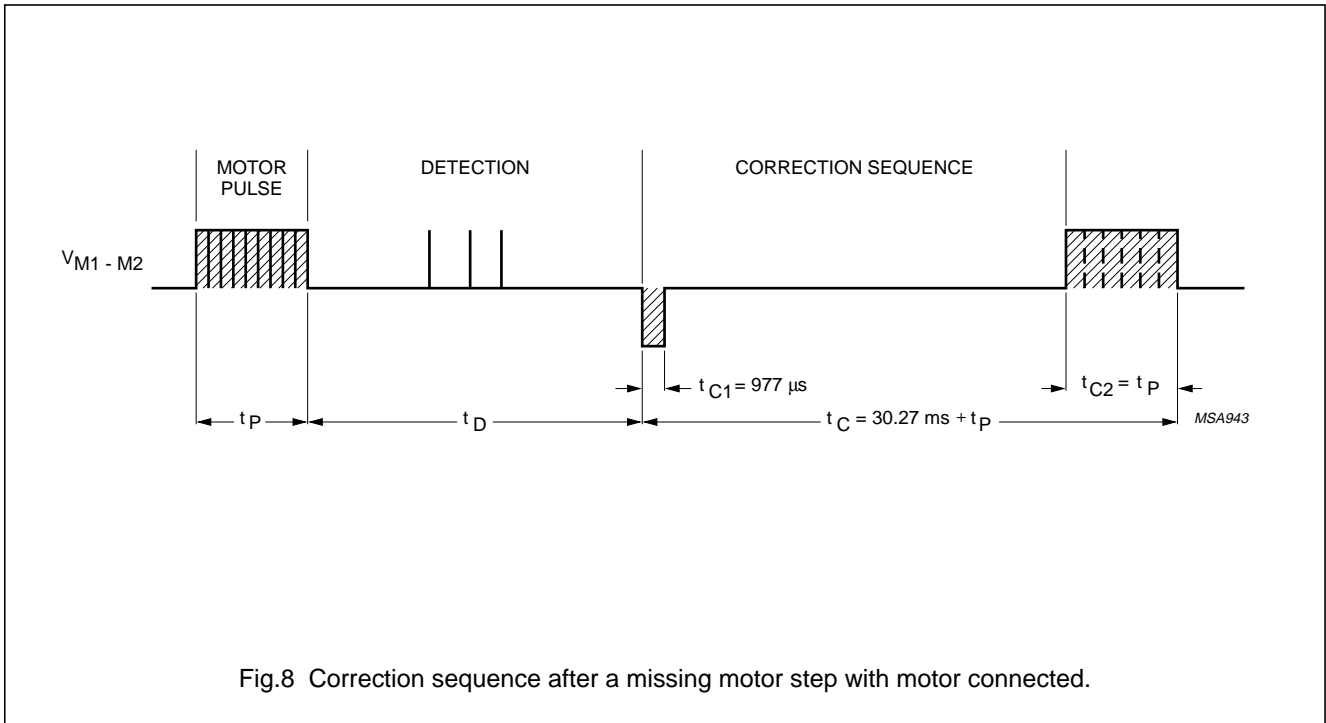

Fig.8 Correction sequence after a missing motor step with motor connected.

# 32 kHz watch circuits with adaptive motor pulse

## PCA146x series

### Time calibration

Taking a normal quartz crystal with frequency 32768kHz, frequency deviation ( $\Delta f/f$ ) of  $\pm 15 \times 10^{-6}$  and  $C_L = 8.2 \text{ pF}$ ; the oscillator frequency is offset (by using non-symmetrical internal oscillator input and output capacitances of 10 pF and 15 pF) such that the frequency deviation is positive-only. This positive deviation can then be compensated for to maintain time-keeping accuracy.

Once the positive frequency deviation is measured, a corresponding number 'n' (see Table 2) can be programmed into the device's EEPROM. This causes n pulses of frequency 8192 Hz to be inhibited every minute of operation, which achieves the required calibration.

The programming circuit is shown in Fig.9. The required number n is programmed into EEPROM by varying  $V_{DD}$  according to the steps shown in Fig.10, which are explained below:

1. The positive quartz frequency deviation ( $\Delta f/f$ ) is measured, and the corresponding values of n are found according to Table 2.
2.  $V_{DD}$  is increased to 5.1 V allowing the contents of the EEPROM to be checked from the motor pulse period  $t_{T3}$  at nominal frequency.

3.  $V_{DD}$  is decreased to 2.5 V during a motor pulse to initialize a storing sequence.
4. The first  $V_{DD}$  pulse to 5.1 V erases the contents of EEPROM.
5. When the EEPROM is erased a logic 1 is at the TEST pin.
6.  $V_{DD}$  is increased to 5.1 V to read the data by pulsing  $V_{DD}$  n times to 4.5 V. After the n edge,  $V_{DD}$  is decreased to 2.5 V.
7.  $V_{DD}$  is increased to 5.1 V to store n bits in the EEPROM.
8.  $V_{DD}$  is decreased to 2.5 V to terminate the storing sequence and to return to operating mode.
9.  $V_{DD}$  is increased to 5.1 V to check writing from the motor pulse period  $t_{T3}$ .
10.  $V_{DD}$  is decreased to the operation voltage **between** two motor pulses to return to operating mode. (Decreasing  $V_{DD}$  during the motor pulse would restart the programming mode).

The time calibration can be reprogrammed up to 100 times.

**Table 2** Quartz crystal frequency deviation, n and  $t_{T3}$

| FREQUENCY DEVIATION $\Delta f/f$ ( $\times 10^{-6}$ ) | NUMBER OF PULSES (n) | $t_{T3}$ (ms)         |
|-------------------------------------------------------|----------------------|-----------------------|
| 0 <sup>(1)</sup>                                      | 0                    | 31.250 <sup>(2)</sup> |
| +2.03                                                 | 1                    | 31.372                |
| +4.06                                                 | 2                    | 31.494                |
| .                                                     | .                    | .                     |
| .                                                     | .                    | .                     |
| .                                                     | .                    | .                     |
| +127.89                                               | 63                   | 38.936                |

### Notes

1. Increments of  $2.03 \times 10^{-6}$ /step.
2. Increments of 122  $\mu\text{s}$ /step.

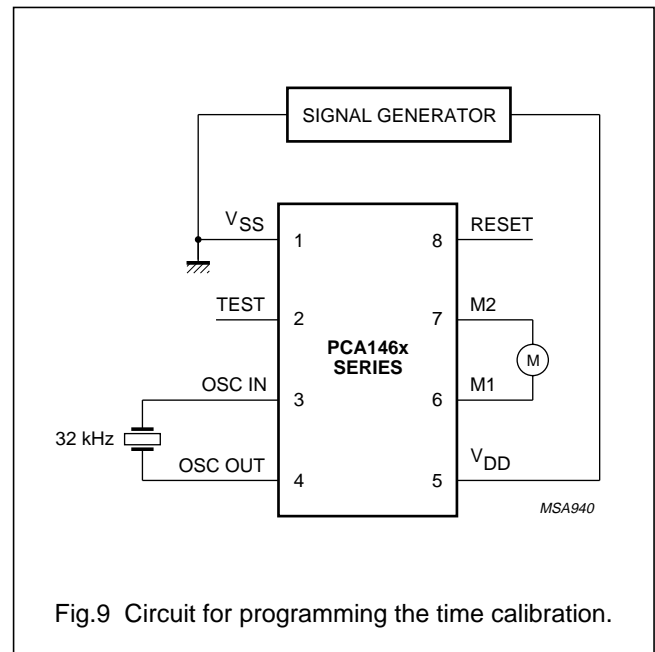
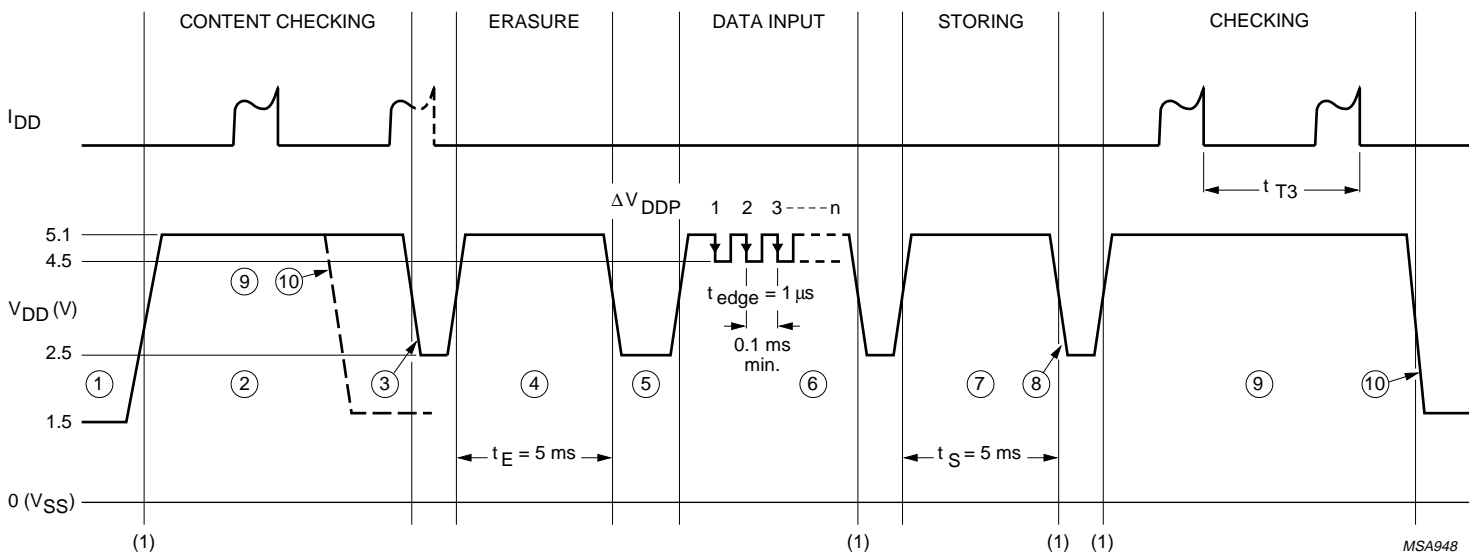

Fig.9 Circuit for programming the time calibration.

32 KHz watch circuits with adaptive motor pulse

PCA146x series



(1) Rise and fall time should be greater than 400  $\mu\text{s/V}$  for immediately correct checking.

Fig.10  $V_{DD}$  for programming.

## 32 kHz watch circuits with adaptive motor pulse

## PCA146x series

### Power-on reset

For correct operation of the Power-on reset the rise time of  $V_{DD}$  from 0 V to 2.1 V should be less than 0.1 ms. All resettable flip-flops are reset. Additionally the polarity of the first motor pulse is positive:  $V_{M1} - V_{M2} \geq 0$  V.

### Customer testing

An output frequency of 32 Hz is provided at RESET (pin 8) to be used for exact frequency measurement. Every minute a jitter occurs as a result of the inhibition, which occurs 90 to 150 ms after disconnecting the RESET from  $V_{DD}$ .

Connecting the RESET to  $V_{DD}$  stops the motor pulses leaving them in a 3-state mode and sets the motor pulse width for the next available motor pulse to stage 1 in the silver-oxide mode. A 32 Hz signal without jitter is produced at the TEST pin.

Debounce time RESET = 14.7 to 123.2 ms.

Connecting RESET to  $V_{SS}$  activates Tests 1 and 2 and disables the inhibition.

**Test 1,  $V_{DD} > V_{EOL}$ .** Normal function takes place except that the motor pulse period is  $t_{T1} = 125$  ms instead of  $t_T$ , and the motor pulse stage is reduced every second instead of every 8 minutes. At TEST a speeded-up 8 minute signal is available.

**Test 2,  $V_{DD} < V_{EOL}$ .** Motor pulses of stage 8 are produced, with a time period of  $t_{T2} = 31.25$  ms.

Test and reset modes are terminated by disconnecting the RESET pin.

**Test 3,  $V_{DD} > 5.1$  V.** Motor pulses of stage 8 are produced, with a time period of  $t_{T3} = 31.25$  ms and  $n \times 122 \mu\text{s}$  to check the contents of the EEPROM. At TEST a speeded-up cycle for motor pulse period signal  $t_T$  is available at 1024 times its normal frequency. Decreasing  $V_{DD}$  voltage level to lower than 2.5 V between two motor pulses returns the circuit to normal operating conditions.

### AVAILABLE TYPES

Refer to Chapters "Ordering information" and "Functional description and testing".

| SHORT TYPE NUMBER | DELIVERY FORMAT <sup>(1)</sup> | PERIOD $t_T$ (s) | SPECIFICATIONS         |                |                     |        |                       | REMARKS                 |
|-------------------|--------------------------------|------------------|------------------------|----------------|---------------------|--------|-----------------------|-------------------------|
|                   |                                |                  | PULSE WIDTH $t_p$ (ms) | DRIVE (%)      | DETECTION CRITERION | EEPROM | BATTERY EOL DETECTION |                         |
| 1461              | U; U/10                        | 1                | 7.8                    | max. 100<br>81 | P = 1<br>N = 2      | yes    | yes                   | 1.5 V and 2.1 V Lithium |
| 1462              | U; U/7;<br>U/10                | 1                | 5.8                    | max. 100<br>81 | P = 1<br>N = 2      | yes    | yes                   | 1.5 V and 2.1 V Lithium |
| 1463              | U; U/10                        | 1                | 3.9                    | max. 100<br>81 | P = 1<br>N = 2      | yes    | yes                   | 1.5 V and 2.1 V Lithium |
| 1465              | U/10; U/7                      | 1                | 5.8                    | max. 100       | P = 1<br>N = 2      | yes    | no                    | 1.5 V                   |
| 1467              | U/10                           | 1                | 7.8                    | max. 100       | P = 1<br>N = 2      | yes    | no                    | 1.5 V                   |

### Note

1. U = Chip in tray; U/7 = chip with bumps on tape; U/10 = chip on foil.

## 32 kHz watch circuits with adaptive motor pulse

## PCA146x series

### LIMITING VALUES

In accordance with the Absolute Maximum Rating System (IEC 134).

| SYMBOL    | PARAMETER                     | CONDITIONS             | MIN.       | MAX.     | UNIT |
|-----------|-------------------------------|------------------------|------------|----------|------|
| $V_{DD}$  | supply voltage                | $V_{SS} = 0$ V; note 1 | -1.8       | +6       | V    |
| $V_I$     | all input voltages            |                        | $V_{SS}$   | $V_{DD}$ | V    |
|           | output short-circuit duration |                        | indefinite |          |      |
| $T_{amb}$ | operating ambient temperature |                        | -10        | +60      | °C   |
| $T_{stg}$ | storage temperature           |                        | -30        | +100     | °C   |

### Note

1. Connecting the battery with reversed polarity does not destroy the circuit, but in this condition a large current flows, which will rapidly discharge the battery.

### HANDLING

Inputs and outputs are protected against electrostatic discharges in normal handling. However, to be totally safe, it is advisable to take handling precautions appropriate to handling MOS devices. Advice can be found in "Data Handbook IC16, General, Handling MOS Devices".

### CHARACTERISTICS

$V_{DD} = 1.55$  V;  $V_{SS} = 0$  V;  $f_{osc} = 32.768$  kHz;  $T_{amb} = 25$  °C; crystal:  $R_S = 20$  k $\Omega$ ;  $C_1 = 2$  to 3 fF;  $C_L = 8$  to 10 pF;  $C_0 = 1$  to 3 pF; unless otherwise specified.

Immunity against parasitic impedance = 20 M $\Omega$  between adjacent pins.

| SYMBOL              | PARAMETER                           | CONDITIONS                                         | MIN. | TYP. | MAX. | UNIT     |
|---------------------|-------------------------------------|----------------------------------------------------|------|------|------|----------|
| <b>Supply</b>       |                                     |                                                    |      |      |      |          |
| $V_{DD1}$           | supply voltage                      | $T_{amb} = -10$ to $+60$ °C                        | 1.2  | 1.55 | 2.5  | V        |
| $\Delta V_{DD}$     | supply voltage variation            | transient within 1.2 V and 2.5 V                   | –    | –    | 0.25 | V        |
| $V_{DD2}$           | supply voltage                      | programming                                        | 5.0  | 5.1  | 5.2  | V        |
| $\Delta V_{DDP}$    | supply voltage pulse variation      | programming                                        | 0.55 | 0.6  | 0.65 | V        |
| $I_{DD1}$           | supply current                      | between motor pulses                               | –    | 170  | 260  | nA       |
| $I_{DD2}$           | supply current                      | $V_{DD} = 2.1$ V                                   | –    | 190  | 300  | nA       |
| $I_{DD3}$           | supply current                      | stop mode; pin 8 connected to $V_{DD}$             | –    | 180  | 280  | nA       |
| $I_{DD4}$           | supply current                      | $V_{DD} = 2.1$ V                                   | –    | 220  | 360  | nA       |
| $I_{DD5}$           | supply current                      | $T_{amb} = -10$ to $+60$ °C                        | –    | –    | 600  | nA       |
| <b>Motor output</b> |                                     |                                                    |      |      |      |          |
| $V_{sat}$           | saturation voltage $\Sigma$ (P + N) | $R_M = 2$ k $\Omega$ ; $T_{amb} = -10$ to $+60$ °C | –    | 150  | 200  | mV       |
| $Z_{o(sc)}$         | output short-circuit impedance      | between motor pulses<br>$I_{transistor} < 1$ mA    | –    | 200  | 300  | $\Omega$ |

## 32 kHz watch circuits with adaptive motor pulse

## PCA146x series

| SYMBOL                        | PARAMETER               | CONDITIONS                               | MIN. | TYP.                  | MAX.                 | UNIT          |
|-------------------------------|-------------------------|------------------------------------------|------|-----------------------|----------------------|---------------|
| <b>Oscillator</b>             |                         |                                          |      |                       |                      |               |
| $V_{OSC\ ST}$                 | starting voltage        |                                          | 1.2  | –                     | –                    | V             |
| $g_m$                         | transconductance        | $V_{i(p-p)} \leq 50\text{ mV}$           | 6    | 15                    | –                    | $\mu\text{S}$ |
| $t_{osc}$                     | start-up time           |                                          | –    | 1                     | –                    | s             |
| $\Delta f/f$                  | frequency stability     | $\Delta V_{DD} = 100\text{ mV}$          | –    | $0.05 \times 10^{-6}$ | $0.3 \times 10^{-6}$ |               |
| $C_i$                         | input capacitance       |                                          | 8    | 10                    | 12                   | pF            |
| $C_o$                         | output capacitance      |                                          | 12   | 15                    | 18                   | pF            |
| <b>Voltage level detector</b> |                         |                                          |      |                       |                      |               |
| $V_{LIT}$                     | threshold voltage       |                                          | 1.62 | 1.80                  | 1.98                 | V             |
| $V_{EOL}$                     | threshold voltage       |                                          | 1.30 | 1.38                  | 1.46                 | V             |
| $\Delta V_{EOL}$              | hysteresis of threshold |                                          | –    | 10                    | –                    | mV            |
| $TC_{EOL}$                    | temperature coefficient |                                          | –    | –1                    | –                    | mV/K          |
| <b>Reset input</b>            |                         |                                          |      |                       |                      |               |
| $f_o$                         | output frequency        |                                          | –    | 32                    | –                    | Hz            |
| $\Delta V_o$                  | output voltage swing    | $R = 1\text{ M}\Omega; C = 10\text{ pF}$ | 1.4  | –                     | –                    | V             |
| $t_{edge}$                    | edge time               | $R = 1\text{ M}\Omega; C = 10\text{ pF}$ | –    | 1                     | –                    | $\mu\text{s}$ |
| $I_{im}$                      | peak input current      | note 1                                   | –    | 320                   | –                    | nA            |
| $I_{i(av)}$                   | average input current   |                                          | –    | 10                    | –                    | nA            |

**Note**

1. Duty factor is 1 : 32 and RESET =  $V_{DD}$  or  $V_{SS}$ .

## 32 kHz watch circuits with adaptive motor pulse

## PCA146x series

## TIMING PARAMETERS

| SYMBOL     | PARAMETER                                                 | SECTION                       | VALUE         | OPTION          | UNIT    |
|------------|-----------------------------------------------------------|-------------------------------|---------------|-----------------|---------|
| $t_T$      | cycle for motor pulse (note 1)                            | motor pulse (Figs 2, 3 and 4) | 1             | 5, 10, 12 or 20 | s       |
| $t_P$      | motor pulse width                                         |                               | 7.81          | 3.9 or 5.9      | ms      |
| $t_{DF}$   | duty factor                                               |                               | 977           | –               | $\mu$ s |
| $t_{ONL}$  | last duty factor on                                       |                               | 61 to 305     | –               | $\mu$ s |
| $t_V$      | voltage detection cycle                                   | level mode                    | 60            | –               | s       |
| $t_{SON}$  | duty factor on                                            | silver-oxide mode (Fig.3)     | 550 to 794    | –               | $\mu$ s |
| $t_{SOFF}$ | duty factor off                                           |                               | 427 to 183    | –               | $\mu$ s |
| $t_{SONF}$ | first duty factor on                                      |                               | 488           | –               | $\mu$ s |
| $t_{AOFF}$ | additional duty factor off                                | lithium mode (Fig.4)          | 183           | –               | $\mu$ s |
| $t_{LON}$  | duty factor on                                            |                               | 305 to 611    | –               | $\mu$ s |
| $t_{LOFF}$ | duty factor off                                           |                               | 672 to 366    | –               | $\mu$ s |
| $t_{LONF}$ | first duty factor on                                      |                               | 244           | –               | $\mu$ s |
| $t_E$      | EOL sequence                                              | end-of-life mode              | 4             | –               | s       |
| $t_{E1}$   | motor pulse width                                         |                               | $t_P$         | –               | ms      |
| $t_{E2}$   | time between pulses                                       |                               | 31.25         | –               | ms      |
| $t_D$      | detection sequence                                        | detection (Fig.7)             | 4.3 to 28.3   | –               | ms      |
| $t_{DS}$   | short-circuited motor                                     |                               | 977           | –               | $\mu$ s |
| $t_{DI}$   | dissipation of energy                                     |                               | 977           | –               | $\mu$ s |
| $t_{MC}$   | measurement cycle                                         |                               | 488           | –               | $\mu$ s |
| $t_{M1}$   | phase 1                                                   |                               | 244           | –               | $\mu$ s |
| $t_{M2}$   | phase 2 (measure window)                                  |                               | 61            | –               | $\mu$ s |
| $t_{M3}$   | phase 3                                                   |                               | 122           | –               | $\mu$ s |
| $t_{M4}$   | phase 4                                                   |                               | 61            | –               | $\mu$ s |
| P          | positive current polarities                               |                               | 1             | P < N           |         |
| N          | negative current polarities                               |                               | 2             | 2 to 6          |         |
| $t_C$      | correction sequence                                       | correction sequence (Fig.8)   | $t_P + 30.27$ | –               | ms      |
| $t_{C1}$   | small pulse width                                         |                               | 977           | –               | $\mu$ s |
| $t_{C2}$   | large pulse width                                         |                               | $t_P$         | –               | ms      |
| $t_{T1}$   | cycles for motor-pulses in:<br>test 1<br>test 2<br>test 3 | testing<br><br>Fig.10         | 125           | –               | ms      |
| $t_{T2}$   |                                                           |                               | 31.25         | –               | ms      |
| $t_{T3}$   |                                                           |                               | 31.25 to 39   | –               | ms      |
| $t_{DEB}$  | debounce time for<br>RESET = $V_{DD}$                     |                               | 14.7 to 123.2 | –               | ms      |

## Note

1. No option available when EOL indication is required.



32 kHz watch circuits with adaptive motor pulse

PCA146x series

CHIP DIMENSIONS AND BONDING PAD LOCATIONS

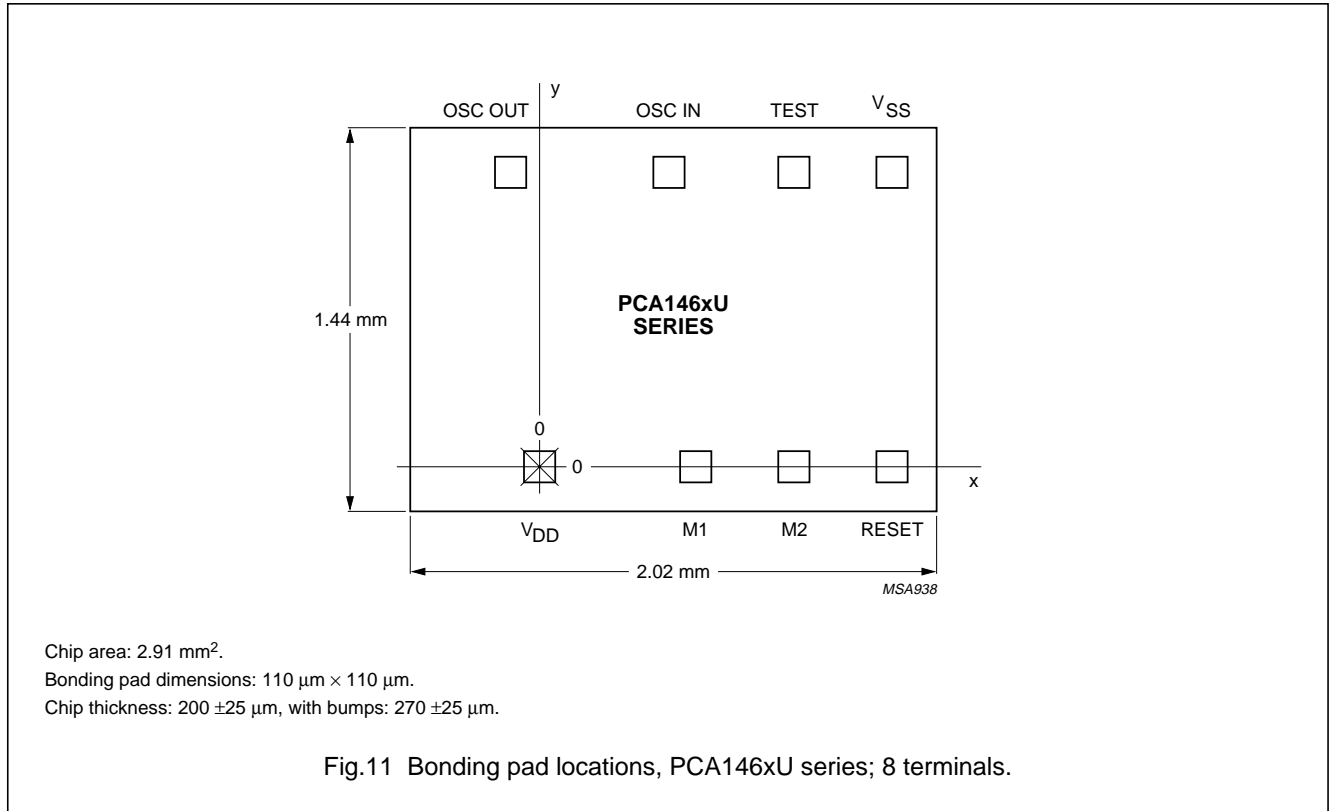

**Table 3** Bonding pad locations (dimensions in μm)

All x/y coordinates are referenced to bottom left pad (V<sub>DD</sub>), see Fig.11.

| PAD                      | x      | y    |
|--------------------------|--------|------|
| V <sub>SS</sub>          | 1290   | 1100 |
| TEST                     | 940    | 1100 |
| OSC IN                   | 481    | 1100 |
| OSC OUT                  | -102   | 1100 |
| V <sub>DD</sub>          | 0      | 0    |
| M1                       | 578    | 0    |
| M2                       | 930    | 0    |
| RESET                    | 1290   | 0    |
| chip corner (max. value) | -497.5 | -170 |

32 kHz watch circuits with adaptive motor pulse

PCA146x series

APPLICATION INFORMATION

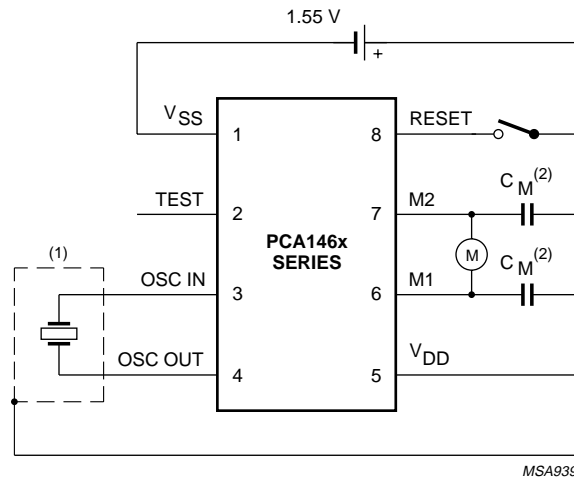

- (1) Quartz crystal case should be connected to  $V_{DD}$ . Stray capacitance and leakage resistance from RESET, M1 or M2 to OSC IN should be less than 0.5 pF or larger than 20 M $\Omega$ .
- (2) Motor, probe and stray capacitance from M2 or M1 to  $V_{DD}$  or  $V_{SS}$  should be less than  $C_M = 80$  pF for correct operation of the detection circuit. Driving the motor at its minimum energy, probe and stray capacitance must be avoided.

Fig.12 Typical application circuit diagram.

# 32 kHz watch circuits with adaptive motor pulse

## PCA146x series

### PACKAGE OUTLINE

PMFP8: plastic micro flat package; 8 leads (straight)

SOT144-1

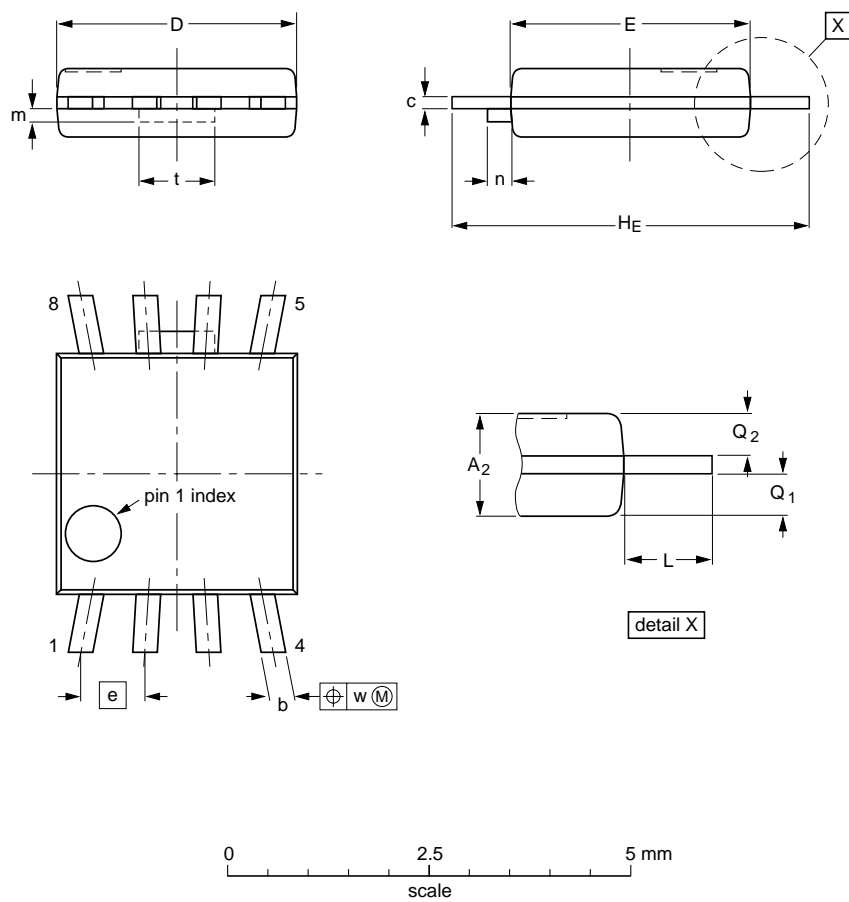

**DIMENSIONS (mm are the original dimensions)**

| UNIT | $A_2$        | $b$          | $c$          | $D^{(1)}$  | $E^{(1)}$  | $e$  | $H_E$      | $L$  | $m$<br>max. | $n$<br>max. | $Q_1$        | $Q_2$        | $t$  | $w$ |
|------|--------------|--------------|--------------|------------|------------|------|------------|------|-------------|-------------|--------------|--------------|------|-----|
| mm   | 0.90<br>0.70 | 0.40<br>0.25 | 0.19<br>0.12 | 3.1<br>2.9 | 3.1<br>2.9 | 0.80 | 4.6<br>4.4 | 0.75 | 0.26        | 0.3         | 0.40<br>0.30 | 0.40<br>0.30 | 0.95 | 0.1 |

**Note**

1. Plastic or metal protrusions of 0.15 mm maximum per side are not included.

| OUTLINE VERSION | REFERENCES |       |      |  | EUROPEAN PROJECTION | ISSUE DATE           |
|-----------------|------------|-------|------|--|---------------------|----------------------|
|                 | IEC        | JEDEC | EIAJ |  |                     |                      |
| SOT144-1        |            |       |      |  |                     | 94-01-25<br>95-01-24 |

## 32 kHz watch circuits with adaptive motor pulse

## PCA146x series

### SOLDERING

#### Introduction

There is no soldering method that is ideal for all IC packages. Wave soldering is often preferred when through-hole and surface mounted components are mixed on one printed-circuit board. However, wave soldering is not always suitable for surface mounted ICs, or for printed-circuits with high population densities. In these situations reflow soldering is often used.

This text gives a very brief insight to a complex technology. A more in-depth account of soldering ICs can be found in our "*IC Package Databook*" (order code 9398 652 90011).

#### Reflow soldering

Reflow soldering techniques are suitable for all SO packages.

Reflow soldering requires solder paste (a suspension of fine solder particles, flux and binding agent) to be applied to the printed-circuit board by screen printing, stencilling or pressure-syringe dispensing before package placement.

Several techniques exist for reflowing; for example, thermal conduction by heated belt. Dwell times vary between 50 and 300 seconds depending on heating method. Typical reflow temperatures range from 215 to 250 °C.

Preheating is necessary to dry the paste and evaporate the binding agent. Preheating duration: 45 minutes at 45 °C.

#### Wave soldering

Wave soldering techniques can be used for all SO packages if the following conditions are observed:

- A double-wave (a turbulent wave with high upward pressure followed by a smooth laminar wave) soldering technique should be used.
- The longitudinal axis of the package footprint must be parallel to the solder flow.
- The package footprint must incorporate solder thieves at the downstream end.

During placement and before soldering, the package must be fixed with a droplet of adhesive. The adhesive can be applied by screen printing, pin transfer or syringe dispensing. The package can be soldered after the adhesive is cured.

Maximum permissible solder temperature is 260 °C, and maximum duration of package immersion in solder is 10 seconds, if cooled to less than 150 °C within 6 seconds. Typical dwell time is 4 seconds at 250 °C.

A mildly-activated flux will eliminate the need for removal of corrosive residues in most applications.

#### Repairing soldered joints

Fix the component by first soldering two diagonally-opposite end leads. Use only a low voltage soldering iron (less than 24 V) applied to the flat part of the lead. Contact time must be limited to 10 seconds at up to 300 °C. When using a dedicated tool, all other leads can be soldered in one operation within 2 to 5 seconds between 270 and 320 °C.

## 32 kHz watch circuits with adaptive motor pulse

PCA146x series

### DEFINITIONS

| <b>Data sheet status</b>                                                                                                                                                                                                                                                                                                                                                                                                                                  |                                                                                       |
|-----------------------------------------------------------------------------------------------------------------------------------------------------------------------------------------------------------------------------------------------------------------------------------------------------------------------------------------------------------------------------------------------------------------------------------------------------------|---------------------------------------------------------------------------------------|
| Objective specification                                                                                                                                                                                                                                                                                                                                                                                                                                   | This data sheet contains target or goal specifications for product development.       |
| Preliminary specification                                                                                                                                                                                                                                                                                                                                                                                                                                 | This data sheet contains preliminary data; supplementary data may be published later. |
| Product specification                                                                                                                                                                                                                                                                                                                                                                                                                                     | This data sheet contains final product specifications.                                |
| <b>Limiting values</b>                                                                                                                                                                                                                                                                                                                                                                                                                                    |                                                                                       |
| Limiting values given are in accordance with the Absolute Maximum Rating System (IEC 134). Stress above one or more of the limiting values may cause permanent damage to the device. These are stress ratings only and operation of the device at these or at any other conditions above those given in the Characteristics sections of the specification is not implied. Exposure to limiting values for extended periods may affect device reliability. |                                                                                       |
| <b>Application information</b>                                                                                                                                                                                                                                                                                                                                                                                                                            |                                                                                       |
| Where application information is given, it is advisory and does not form part of the specification.                                                                                                                                                                                                                                                                                                                                                       |                                                                                       |

### LIFE SUPPORT APPLICATIONS

These products are not designed for use in life support appliances, devices, or systems where malfunction of these products can reasonably be expected to result in personal injury. Philips customers using or selling these products for use in such applications do so at their own risk and agree to fully indemnify Philips for any damages resulting from such improper use or sale.

32 kHz watch circuits with adaptive motor  
pulse

PCA146x series

---

**NOTES**

---

32 kHz watch circuits with adaptive motor  
pulse

---

PCA146x series

**NOTES**

# Philips Semiconductors – a worldwide company

**Argentina:** see South America

**Australia:** 34 Waterloo Road, NORTH RYDE, NSW 2113,  
Tel. +61 2 9805 4455, Fax. +61 2 9805 4466

**Austria:** Computerstr. 6, A-1101 WIEN, P.O. Box 213, Tel. +43 160 1010,  
Fax. +43 160 101 1210

**Belarus:** Hotel Minsk Business Center, Bld. 3, r. 1211, Volodarski Str. 6,  
220050 MINSK, Tel. +375 172 200 733, Fax. +375 172 200 773

**Belgium:** see The Netherlands

**Brazil:** see South America

**Bulgaria:** Philips Bulgaria Ltd., Energoproject, 15th floor,  
51 James Bourchier Blvd., 1407 SOFIA,  
Tel. +359 2 689 211, Fax. +359 2 689 102

**Canada:** PHILIPS SEMICONDUCTORS/COMPONENTS,  
Tel. +1 800 234 7381

**China/Hong Kong:** 501 Hong Kong Industrial Technology Centre,  
72 Tat Chee Avenue, Kowloon Tong, HONG KONG,  
Tel. +852 2319 7888, Fax. +852 2319 7700

**Colombia:** see South America

**Czech Republic:** see Austria

**Denmark:** Prags Boulevard 80, PB 1919, DK-2300 COPENHAGEN S,  
Tel. +45 32 88 2636, Fax. +45 31 57 0044

**Finland:** Sinikalliontie 3, FIN-02630 ESPOO,  
Tel. +358 9 615800, Fax. +358 9 61580920

**France:** 51 Rue Carnot, BP317, 92156 SURESNES Cedex,  
Tel. +33 1 40 99 6161, Fax. +33 1 40 99 6427

**Germany:** Hammerbrookstraße 69, D-20097 HAMBURG,  
Tel. +49 40 23 53 60, Fax. +49 40 23 536 300

**Greece:** No. 15, 25th March Street, GR 17778 TAVROS/ATHENS,  
Tel. +30 1 4894 339/239, Fax. +30 1 4814 240

**Hungary:** see Austria

**India:** Philips INDIA Ltd, Band Box Building, 2nd floor,  
254-D, Dr. Annie Besant Road, Worli, MUMBAI 400 025,  
Tel. +91 22 493 8541, Fax. +91 22 493 0966

**Indonesia:** see Singapore

**Ireland:** Newstead, Clonskeagh, DUBLIN 14,  
Tel. +353 1 7640 000, Fax. +353 1 7640 200

**Israel:** RAPAC Electronics, 7 Kehilat Saloniki St, PO Box 18053,  
TEL AVIV 61180, Tel. +972 3 645 0444, Fax. +972 3 649 1007

**Italy:** PHILIPS SEMICONDUCTORS, Piazza IV Novembre 3,  
20124 MILANO, Tel. +39 2 6752 2531, Fax. +39 2 6752 2557

**Japan:** Philips Bldg 13-37, Kohnan 2-chome, Minato-ku, TOKYO 108,  
Tel. +81 3 3740 5130, Fax. +81 3 3740 5077

**Korea:** Philips House, 260-199 Itaewon-dong, Yongsan-ku, SEOUL,  
Tel. +82 2 709 1412, Fax. +82 2 709 1415

**Malaysia:** No. 76 Jalan Universiti, 46200 PETALING JAYA, SELANGOR,  
Tel. +60 3 750 5214, Fax. +60 3 757 4880

**Mexico:** 5900 Gateway East, Suite 200, EL PASO, TEXAS 79905,  
Tel. +9-5 800 234 7381

**Middle East:** see Italy

**Netherlands:** Postbus 90050, 5600 PB EINDHOVEN, Bldg. VB,  
Tel. +31 40 27 82785, Fax. +31 40 27 88399

**New Zealand:** 2 Wagener Place, C.P.O. Box 1041, AUCKLAND,  
Tel. +64 9 849 4160, Fax. +64 9 849 7811

**Norway:** Box 1, Manglerud 0612, OSLO,  
Tel. +47 22 74 8000, Fax. +47 22 74 8341

**Philippines:** Philips Semiconductors Philippines Inc.,  
106 Valero St. Salcedo Village, P.O. Box 2108 MCC, MAKATI,  
Metro MANILA, Tel. +63 2 816 6380, Fax. +63 2 817 3474

**Poland:** Ul. Lukiska 10, PL 04-123 WARSZAWA,  
Tel. +48 22 612 2831, Fax. +48 22 612 2327

**Portugal:** see Spain

**Romania:** see Italy

**Russia:** Philips Russia, Ul. Usatcheva 35A, 119048 MOSCOW,  
Tel. +7 095 755 6918, Fax. +7 095 755 6919

**Singapore:** Lorong 1, Toa Payoh, SINGAPORE 1231,  
Tel. +65 350 2538, Fax. +65 251 6500

**Slovakia:** see Austria

**Slovenia:** see Italy

**South Africa:** S.A. PHILIPS Pty Ltd., 195-215 Main Road Martindale,  
2092 JOHANNESBURG, P.O. Box 7430 Johannesburg 2000,  
Tel. +27 11 470 5911, Fax. +27 11 470 5494

**South America:** Al. Vicente Pinzon, 173, 6th floor,  
04547-130 SÃO PAULO, SP, Brazil,  
Tel. +55 11 821 2333, Fax. +55 11 821 2382

**Spain:** Balmes 22, 08007 BARCELONA,  
Tel. +34 3 301 6312, Fax. +34 3 301 4107

**Sweden:** Kottbygatan 7, Akalla, S-16485 STOCKHOLM,  
Tel. +46 8 632 2000, Fax. +46 8 632 2745

**Switzerland:** Allmendstrasse 140, CH-8027 ZÜRICH,  
Tel. +41 1 488 2686, Fax. +41 1 488 3263

**Taiwan:** Philips Semiconductors, 6F, No. 96, Chien Kuo N. Rd., Sec. 1,  
TAIPEI, Taiwan Tel. +886 2 2134 2865, Fax. +886 2 2134 2874

**Thailand:** PHILIPS ELECTRONICS (THAILAND) Ltd.,  
209/2 Sanpavuth-Bangna Road Prakanong, BANGKOK 10260,  
Tel. +66 2 745 4090, Fax. +66 2 398 0793

**Turkey:** Talatpasa Cad. No. 5, 80640 GÜLTEPE/ISTANBUL,  
Tel. +90 212 279 2770, Fax. +90 212 282 6707

**Ukraine:** PHILIPS UKRAINE, 4 Patrice Lumumba str., Building B, Floor 7,  
252042 KIEV, Tel. +380 44 264 2776, Fax. +380 44 268 0461

**United Kingdom:** Philips Semiconductors Ltd., 276 Bath Road, Hayes,  
MIDDLESEX UB3 5BX, Tel. +44 181 730 5000, Fax. +44 181 754 8421

**United States:** 811 East Arques Avenue, SUNNYVALE, CA 94088-3409,  
Tel. +1 800 234 7381

**Uruguay:** see South America

**Vietnam:** see Singapore

**Yugoslavia:** PHILIPS, Trg N. Pasica 5/v, 11000 BEOGRAD,  
Tel. +381 11 625 344, Fax. +381 11 635 777

**For all other countries apply to:** Philips Semiconductors,  
International Marketing & Sales Communications, Building BE-p, P.O. Box 218,  
5600 MD EINDHOVEN, The Netherlands, Fax. +31 40 27 24825

**Internet:** <http://www.semiconductors.philips.com>

© Philips Electronics N.V. 1998

SCA57

All rights are reserved. Reproduction in whole or in part is prohibited without the prior written consent of the copyright owner.

The information presented in this document does not form part of any quotation or contract, is believed to be accurate and reliable and may be changed without notice. No liability will be accepted by the publisher for any consequence of its use. Publication thereof does not convey nor imply any license under patent- or other industrial or intellectual property rights.

Printed in The Netherlands

415108/1200/04/pp24

Date of release: 1998 Apr 21

Document order number: 9397 750 03769

*Let's make things better.*

**Philips  
Semiconductors**



**PHILIPS**