

POWER MOSFETS IN A TO-3 PACKAGE

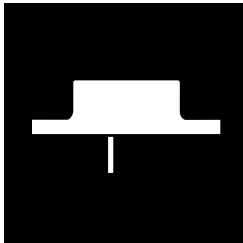

1000V, Up To 6 Amp, N-Channel MOSFETs In A TO-3 Package

FEATURES

- TO-3 Hermetic Package, .060 Dia. Leads
- Fast Switching
- Low $R_{DS(on)}$
- 1000 Volt, Size 5 Die
- Available Screened To MIL-S-19500, TX, TXV And S Levels

DESCRIPTION

This series of hermetically packaged products feature the latest advanced MOSFET and packaging technology. They are ideally suited for Military requirements where small size, high performance and high reliability are required, and in applications such as switching power supplies, motor controls, inverters, choppers, audio amplifiers and high energy pulse circuits.

MAXIMUM RATINGS

PART NUMBER	V_{DS} (V)	$R_{DS(on)}$ ()	I_D (A)
OM5N100NK	1000	3.0	5.0
OM6N100NK	1000	2.0	6.0

3.1

MECHANICAL OUTLINE

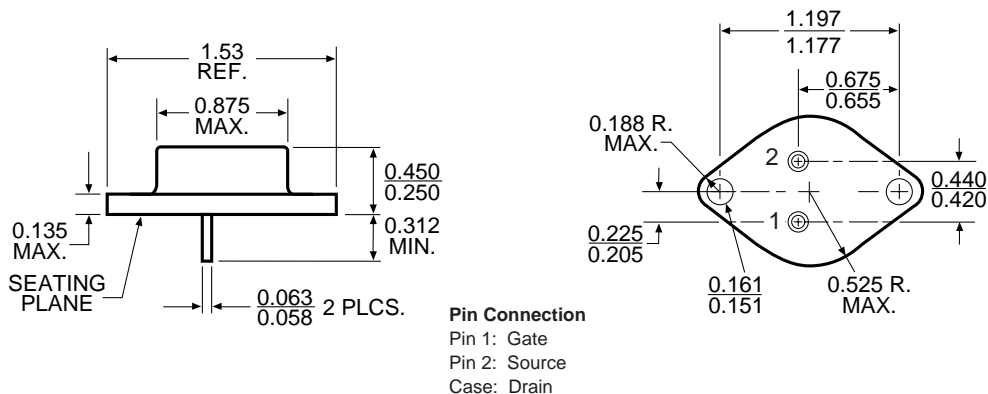

ELECTRICAL CHARACTERISTICS: $T_C = 25^\circ\text{C}$ unless otherwise noted

Parameter	Min.	Typ.	Max.	Units	Test Conditions
BV_{DSS} Drain-Source Breakdown Voltage	1000			V	$V_{GS} = 0$, $I_D = 250\text{ mA}$
$V_{GS(th)}$ Gate-Threshold Voltage	2.0		4.0	V	$V_{DS} = V_{GS}$, $I_D = 250\text{ mA}$
I_{GSSF} Gate-Body Leakage Forward			100	nA	$V_{GS} = 20\text{ V}$, $V_{DS} = 0$
I_{GSSR} Gate-Body Leakage Reverse			- 100	nA	$V_{GS} = - 20\text{ V}$, $V_{DS} = 0$
I_{DSS} Zero Gate Voltage Drain Current			0.25	mA	$V_{DS} = \text{Max. Rat.}$, $V_{GS} = 0$
			1.0	mA	$V_{DS} = 0.8 \times \text{Max. Rat.}$, $V_{GS} = 0$, $T_C = 125^\circ\text{C}$
$I_{D(on)}$ On-State Drain Current	5.0			A	$V_{DS} > I_{D(on)} \times R_{DS(on)Max.}$, $V_{GS} = 10\text{ V}$
$R_{DS(on)}$ Static Drain-Source On-State Resistance ¹ - OM5N100NK			3.0		$V_{GS} = 10\text{ V}$, $I_D = 2.5\text{ A}$
$R_{DS(on)}$ Static Drain-Source On-State Resistance ¹ - OM5N100NK			6.0		$V_{GS} = 10\text{ V}$, $I_D = 2.5\text{ A}$ $T_C = 100^\circ\text{C}$
$R_{DS(on)}$ Static Drain-Source On-State Resistance ¹ - OM6N100NK			2.0		$V_{GS} = 10\text{ V}$, $I_D = 3.0\text{ A}$
$R_{DS(on)}$ Static Drain-Source On-State Resistance ¹ - OM6N100NK			4.0		$V_{GS} = 10\text{ V}$, $I_D = 3.0\text{ A}$ $T_C = 100^\circ\text{C}$

DYNAMIC

g_{fs} Forward Transductance	4.0			S	$V_{DS} = 25\text{ V}$, $I_D = 3.5\text{ A}$
C_{iss} Input Capacitance		2800		pF	$V_{GS} = 0$
C_{oss} Output Capacitance		350		pF	$V_{DS} = 25\text{ V}$
C_{rss} Reverse Transfer Capacitance		130		pF	$f = 1\text{ MHz}$
$T_{d(on)}$ Turn-On Delay Time		65		ns	$V_{DD} = 400\text{ V}$, $I_D = 6\text{ A}$
t_r Rise Time		55		ns	$R_g = 7\ \Omega$, $V_{GS} = 10\text{ V}$
$t_{d(off)}$ Turn-Off Delay Time		62		ns	$V_{DD} = 800\text{ V}$, $I_D = 6\text{ A}$,
t_f Fall Time		25		ns	$R_g = 7\ \Omega$, $V_{GS} = 10\text{ V}$

BODY-DRAIN DIODE RATINGS AND CHARACTERISTICS

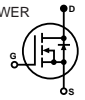
I_S Continuous Source Current (Body Diode)			6	A	Modified MOSPOWER symbol showing the integral P-N Junction rectifier. 
I_{SM} Source Current ² (Body Diode)			24	A	
V_{SD} Diode Forward Voltage ¹			2.5	V	$T_C = 25^\circ\text{C}$, $I_S = 6\text{ A}$, $V_{GS} = 0$
t_{rr} Reverse Recovery Time		1100		ns	$I_F = I_S$, $V_{DD} = 100\text{ V}$, $di_F/ds = 100\text{ A/ms}$, $T_J = 150^\circ\text{C}$

1 Pulse Test: Pulse Width 300msec, Duty Cycle 1.5%.

2 Pulse Width limited by safe operating area.

ABSOLUTE MAXIMUM RATINGS ($T_C = 25^\circ\text{C}$ unless otherwise noted)

Symbol	Parameter	OM5N100NK	OM6N100NK	Units
V_{DS}	Drain-Source Voltage	1000	1000	V
V_{DGR}	Drain-Source Voltage ($R_{GS} = 20\text{ k}$)	1000	1000	V
$I_D @ T_C = 25^\circ\text{C}$	Continuous Drain Current	5.0	6.0	A
$I_D @ T_C = 100^\circ\text{C}$	Continuous Drain Current	3.1	3.7	A
I_{DM}	Pulsed Drain Current ¹	24	24	A
V_{GS}	Gate-Source Voltage	± 20	± 20	V
$P_D @ T_C = 25^\circ\text{C}$	Maximum Power Dissipation	130	130	W
$P_D @ T_C = 100^\circ\text{C}$	Maximum Power Dissipation	51	51	W
Junction-To-Case	Linear Derating Factor	1.00	1.00	$W/^\circ\text{C}$
Junction-To-Ambient	Linear Derating Factor	.033	.033	$W/^\circ\text{C}$
T_J	Operating and			
T_{stg}	Storage Temperature Range	-55 to 150	-55 to 150	$^\circ\text{C}$
Lead Temperature	(1/16" from case for 10secs.)	300	300	$^\circ\text{C}$

1 Pulse Test: Pulse width 300 μsec . Duty Cycle 2%.

THERMAL RESISTANCE (Maximum) at $T_A = 25^\circ\text{C}$

R_{thJC}	Junction-To-Case	Max.	1.0	$^\circ\text{C/W}$	
R_{thJA}	Junction-to-Ambient		30	$^\circ\text{C/W}$	Free Air Operation