



AUDIO PROCESSOR

■ GENERAL DESCRIPTION

The **NJW1173** is an audio processor which includes volume, balance, tone control, surround, simulated stereo and AGC function.

Also the **NJW1173** features high precision characteristics about channel balance, it is less than $\pm 1.0\text{dB}$ at -70dB attenuation.

All of internal status and variables are controlled by I²C BUS.
It is suitable for any TV set.

■ PACKAGE OUTLINE

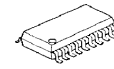

NJW1173V

■ FEATURES

- Operating Voltage 8 to 13V
- I²C BUS Interface
(Fast mode applicable, 3V I/F applicable)
- Low Output Noise
- AGC Circuit (Selectable 4-stage compression level via I²C BUS)
- "eala" (NJRC Surround)
- Simulated Surround
- Bi-CMOS Technology
- Package Outline SSOP20

■ BLOCK DIAGRAM

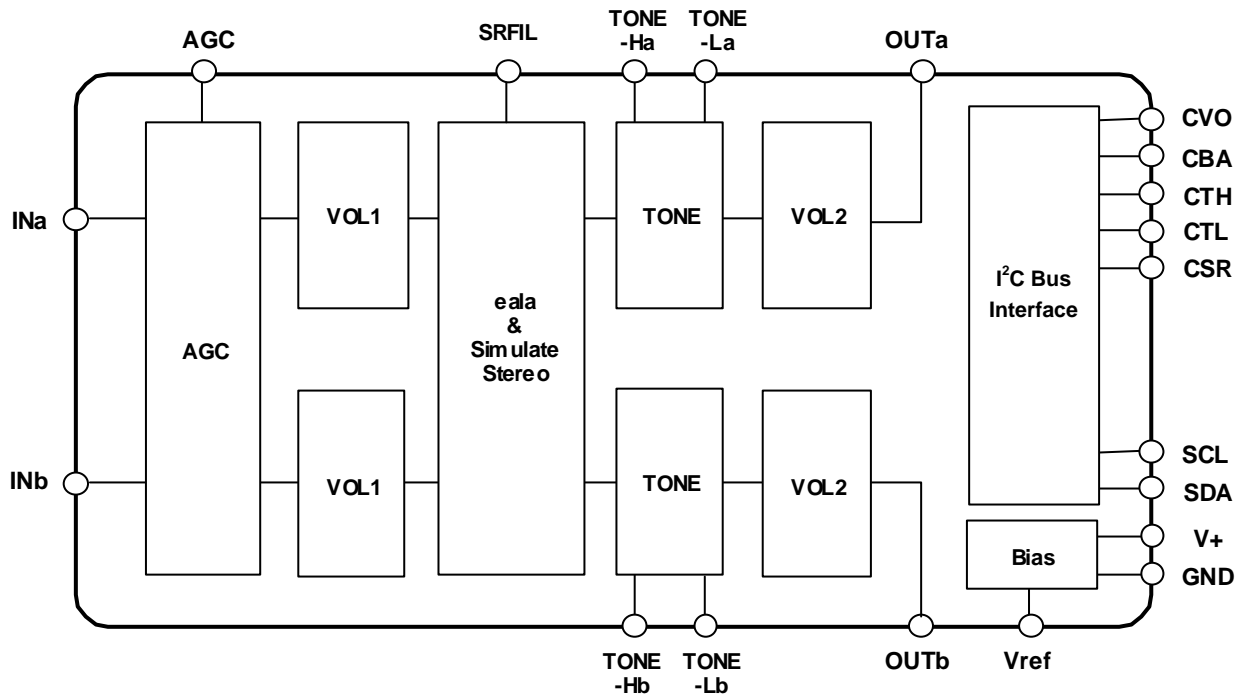

■ PIN CONFIGURATION

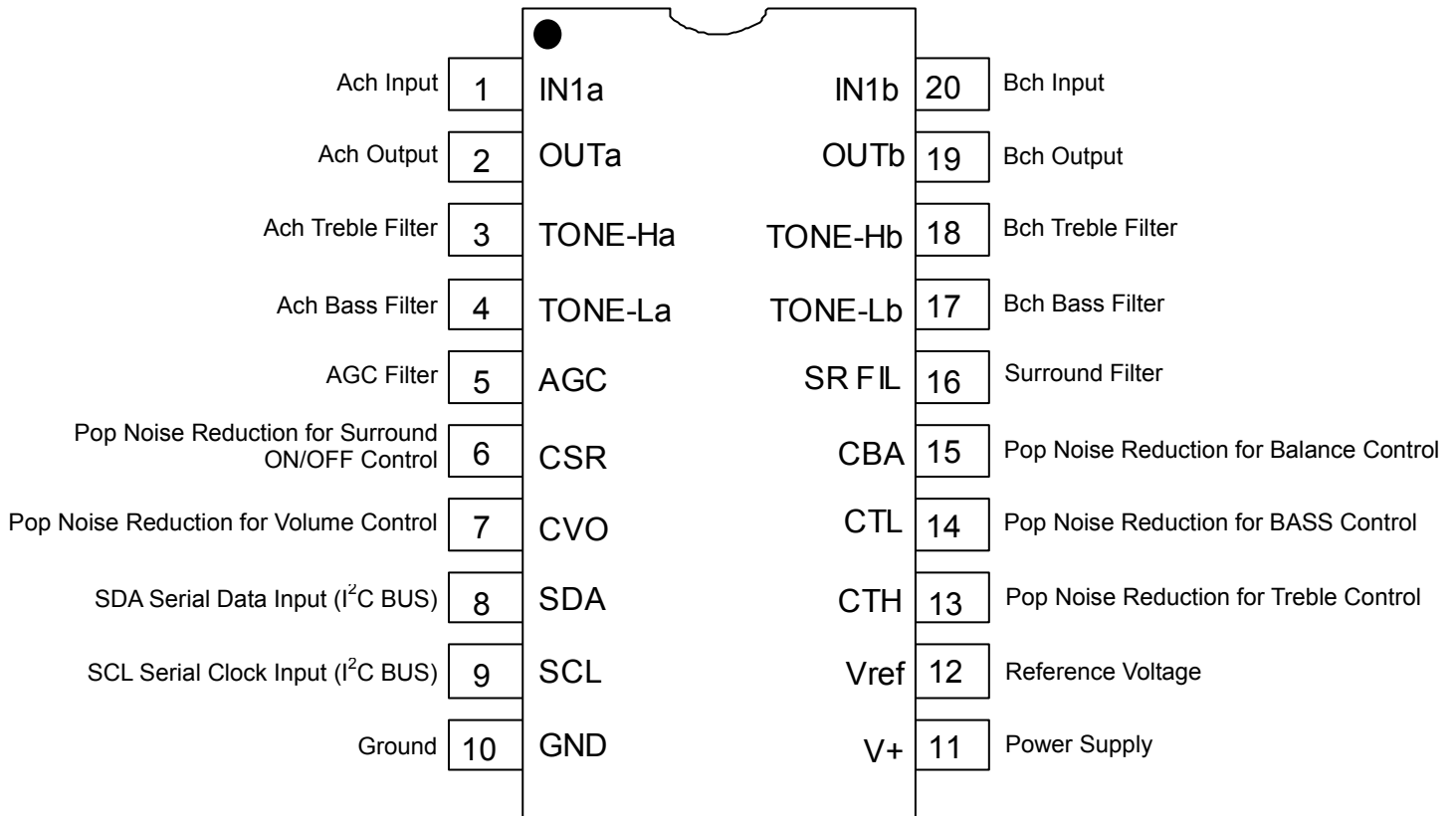

■ ABSOLUTE MAXIMUM RATING (Ta=25°C)

PARAMETER	SYMBOL	RATING	UNIT
Supply Voltage	V ⁺	15	V
Power Dissipation	P _D	350	mW
Operating Temperature Range	Topr	-20 to +75	°C
Storage Temperature Range	Tstg	-40 to +125	°C

■ ELECTRICAL CHARACTERISTICS (Ta=25°C, V+=9V, Rg=600Ω, RL=47kΩ, Vin=100mVrms/1kHz, AGC=OFF, TONE=0dB, Surround=OFF unless otherwise specified)

PARAMETER	SYMBOL	TEST CONDITION	MIN.	TYP.	MAX.	UNIT
Operating Voltage	V ⁺		8.0	9.0	13.0	V
Supply Current	I _{CC}	No Signal	-	13	25	mA
Reference Voltage	V _{REF}	No Signal	4.0	4.5	5.0	V
Maximum Input Voltage	V _{IM}	VOL=-20dB, THD=10%	2.8	3.0	-	Vrms
Maximum Output Voltage	V _{OM}	OUTPUT VOL=0dB, THD=1%	-	2.5	-	Vrms
Channel Balance 1	G _{CB1}	VOL=0dB	-1.0	0.0	1.0	dB
Channel Balance 2	G _{CB2}	VOL=-70dB, Vin=1Vrms	-1.0	0.0	1.0	dB
Balance Boost A	BA _{BST}	CHS="0", BAL="11111"	-2.0	0.0	2.0	dB
Balance Cut A	BA _{CUT}	CHS="1", BAL="11111" Vin = 1Vrms	-	-	-70	dB
Balance Boost B	BB _{BST}	CHS="1", BAL="11111"	-2.0	0.0	2.0	dB
Balance Cut B	BB _{CUT}	CHS="0", BAL="11111" Vin = 1Vrms	-	-	-70	dB
Total Harmonic Distortion	THD	Vo=0.5Vrms BW=400Hz to 30kHz	-	-	0.3	%
Maximum Gain	G _{VMAX}	VOL= 0dB	-2.0	0.0	2.0	dB
Minimum Gain	G _{VMIN}	VOL= MUTE, Vin=2Vrms	-	-100	-90	dB
Channel Separation	CS	Vin = 1Vrms A-weighting	-	-80	-70	dB
Output Noise 1	V _{NO1}	VOL = 0dB A-weighting	-	-90 (31.6)	-85 (56.2)	dBV (μVrms)
Output Noise 2	V _{NO2}	VOL = MUTE A-weighting	-	-106 (5.0)	-96 (15.8)	dBV (μVrms)

BW: Band Width

■ **ELECTRICAL CHARACTERISTICS** (Ta=25°C, V+=9V, Rg=600Ω, RL=47kΩ, Vin=100mVrms/1kHz, AGC=OFF, TONE=0dB, Surround=OFF unless otherwise specified)

◆ **TONE CONTROL**

PARAMETER	SYMBOL	TEST CONDITION	MIN.	TYP.	MAX.	UNIT
High Frequency Boost	HF _{BST}	BCT="1", TREB="1111", f=10kHz	12.5	15.0	17.5	dB
High Frequency Flat	HF _{FLT}	TREB="0000", f=10kHz	-2.0	0.0	2.0	dB
High Frequency Cut	HF _{CUT}	BCT="0", TREB="1111", f=10kHz	-17.5	-15.0	-12.5	dB
Low Frequency Boost	LF _{BST}	BCB="1", BASS="1111", f=100Hz	12.5	15.0	17.5	dB
Low Frequency Flat	LF _{FLT}	BASS="0000", f=100Hz	-2.0	0.0	2.0	dB
Low Frequency Cut	LF _{CUT}	BCB="0", BASS="1111", f=100Hz	-17.5	-15.0	-12.5	dB

◆ **AGC CONTROL (AGC-ON)**

PARAMETER	SYMBOL	TEST CONDITION	MIN.	TYP.	MAX.	UNIT
AGC Boost	AGC _{BST}	Vin=50mVrms, f=1kHz	1.5	3.5	5.5	dB
AGC Flat1	AGC _{FLT1}	Vin=100mVrms, f=1kHz	-2.5	0.0	2.5	dB
AGC Flat2	AGC _{FLT2}	Vin=200mVrms, f=1kHz	-2.5	0.0	2.5	dB
AGC Flat3	AGC _{FLT3}	Vin=300mVrms, f=1kHz	-2.5	0.0	2.5	dB
AGC Flat4	AGC _{FLT4}	Vin=400mVrms, f=1kHz	-2.5	0.0	2.5	dB

◆ **SURROUND (SURROUND-ON)**

PARAMETER	SYMBOL	TEST CONDITION	MIN.	TYP.	MAX.	UNIT
Surround Gain1	SR _{GAIN1}	Ain→Aout, f=100Hz SUR0="1", SUR="1"	6.0	8.0	10.0	dB
Surround Gain2	SR _{GAIN2}	Ain→Bout, f=100Hz SUR0="1", SUR="1"	1.6	3.6	5.6	dB
Surround Gain3	SR _{GAIN3}	Ain→Aout, f=100Hz SUR0="0", SUR="1"	10.0	12.0	14.0	dB
Surround Gain4	SR _{GAIN4}	Ain→Bout, f=100Hz SUR0="0", SUR="1"	7.5	9.5	11.5	dB
Simulated Surround Gain1	SR _{SIM1}	Ain+Bin→Aout, f=1kHz SUR0="1", SUR="0"	1.0	3.0	5.0	dB
Simulated Surround Gain2	SR _{SIM2}	Ain+Bin→Bout, f=1kHz SUR0="1", SUR="0"	1.0	3.0	5.0	dB

■ I²C BUS CHARACTERISTICS (SDA, SCL)

I²C BUS Load Conditions: Pull up resistance 4kΩ (Connected to +5V), Load capacitance 200pF (Connected to GND)

PARAMETER	SYMBOL	Standard mode			Fast mode			UNIT
		MIN.	TYP.	MAX.	MIN.	TYP.	MAX.	
Low Level Input Voltage	V _{IL}	0.0	-	1.5	0.0	-	1.5	V
High Level Input Voltage	V _{IH}	2.7	-	5.0	2.7	-	5.0	V
Hysteresis of Schmitt trigger inputs	V _{hys}	-	-	-	0.25	-	-	V
Low level output voltage (3mA at SDA pin)	V _{OL}	0	-	0.4	0	-	0.4	V
Output fall time from V _{IHmin} to V _{ILmax} with a bus capacitance from 10pF to 400pF	t _{of}	-	-	250	20 +0.1C _b	-	250	ns
Pulse width of spikes which must be suppressed by the input filter	t _{SP}	-	-	-	0	-	50	ns
Input current each I/O pin with an input voltage between 0.1V _{DD} and 0.9V _{DDmax}	I _i	-10	-	10	-10	-	10	μA
Capacitance for each I/O pin	C _i	-	-	10	-	-	10	pF
SCL clock frequency	f _{SCL}	-	-	100	-	-	400	kHz
Hold time (repeated) START condition.	t _{HD:STA}	4.0	-	-	0.6	-	-	μs
Low period of the SCL clock	t _{LOW}	4.7	-	-	1.3	-	-	μs
High period of the SCL clock	t _{HIGH}	4.0	-	-	0.6	-	-	μs
Set-up time for a repeated START condition	t _{SU:STA}	4.7	-	-	0.6	-	-	μs
Data hold time	t _{HD:DAT}	0	-	3.45	0	-	0.9	μs
Data set-up time	t _{SU:DAT}	250	-	-	100	-	-	ns
Rise time of both SDA and SCL signals	t _r	-	-	1000	-	-	300	ns
Fall time of both SDA and SCL signals	t _f	-	-	300	-	-	300	ns
Set-up time for STOP condition	t _{SU:STO}	4.0	-	-	0.6	-	-	μs
Bus free time between a STOP and START condition	t _{BUF}	4.7	-	-	1.3	-	-	μs
Capacitive load for each bus line	C _b	-	-	400	-	-	400	pF
Noise margin at the Low level	V _{nL}	0.5	-	-	0.5	-	-	V
Noise margin at the High level	V _{nH}	1	-	-	1	-	-	V

C_b ; total capacitance of one bus line in pF.

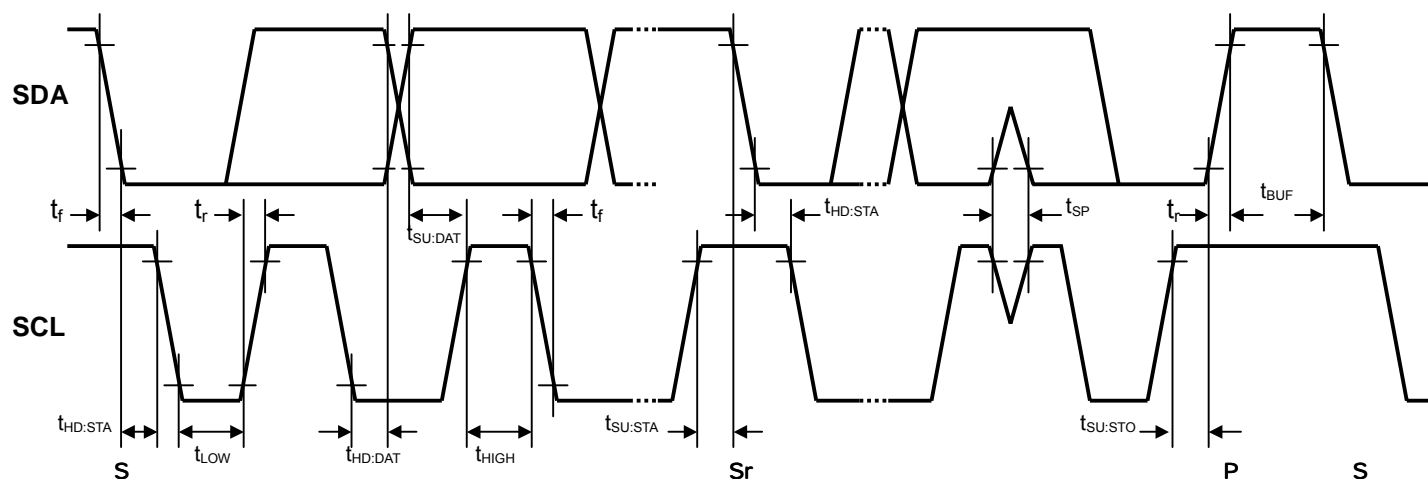

■ TERMINAL DESCRIPTION

No.	SYMBOL	FUNCTION	EQUIVALENT CIRCUIT	VOLTAGE
1 20	INa INb	Ach Input terminal Bch Input terminal		$V^+/2$
2 19	OUTa OUTb	Ach Output terminal Bch Output terminal		$V^+/2$
3 18	TONE-Ha TONE-Hb	Ach Treble Filter terminal Bch Treble Filter terminal		$V^+/2$
4 17	TONE-La TONE-Lb	Ach Bass Filter terminal Bch Bass Filter terminal		$V^+/2$
5	AGC	Capacitor connection terminal for AGC attack and recovery time setting		1.4V

■ TERMINAL DESCRIPTION

No.	SYMBOL	FUNCTION	EQUIVALENT CIRCUIT	VOLTAGE
6	CSR	Pop Noise Reduction for Surround ON/OFF Control		$V^+/2$
7	CVO	Pop Noise Reduction for Volume Control		$V^+/2$
8	SDA	SDA Serial Data Input (I ² C BUS)		
9	SCL	SDA Serial Clock Input (I ² C BUS)		
10	GND	Ground terminal	-	-
11	V+	Power Supply terminal	-	-
12	Vref	Reference Voltage		-

■ TERMINAL DESCRIPTION

No.	SYMBOL	FUNCTION	EQUIVALENT CIRCUIT	VOLTAGE
13	CTH	Pop Noise Reduction for Treble Control		V ⁺ /2
14	CTL	Pop Noise Reduction for Bass Control		
15	CBA	Pop Noise Reduction for Balance Control		
16	SRFIL	Surround filter terminal		V ⁺ /2

APPLICATION CIRCUIT

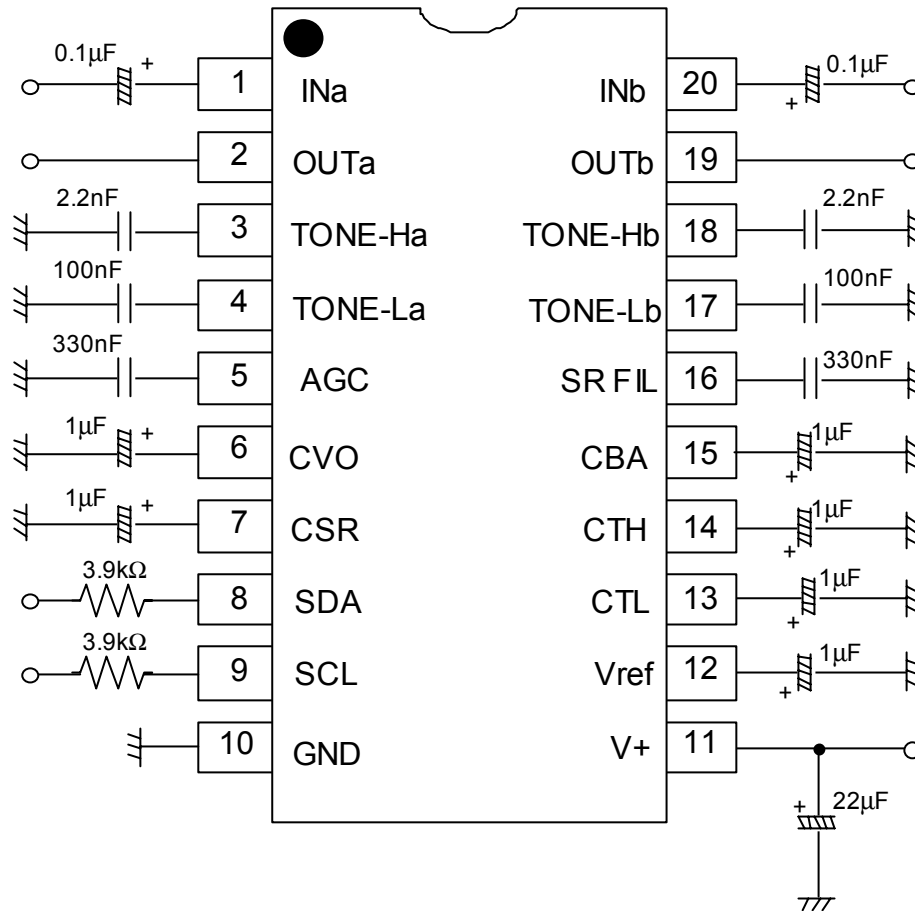

(NOTE) Separate the I²C bus line from the following terminals for avoiding digital noise problem.

Pin No.	Symbol	Pin No.	Symbol	Pin No.	Symbol
3	TONE-Ha	16	SR FIL	18	TONE-Hb
4	TONE-La	17	TONE-Lb	-	-

■ DEFINITION OF I²C REGISTER

● I²C BUS FORMAT

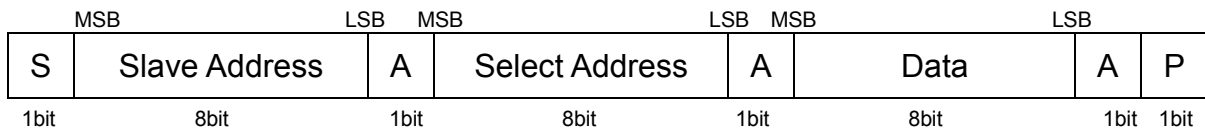

S: Starting Term

A: Acknowledge Bit

P: Ending Term

● SLAVE ADDRESS



$\overline{R/W}$ =0: Write mode for register setting

$\overline{R/W}$ =1: Not available

● CONTROL REGISTER TABLE

The select address sets each function (Volume, Balance, AGC, Tone Control, Surround etc.).

The auto-increment function cycles the select address as follows.

00H→01H→02H→03H→00H

Select Address	BIT							
	D7	D6	D5	D4	D3	D2	D1	D0
00H	VOL							
01H	CHS	BAL					SUR	
02H	BCB	BASS				AGC-SW	AGC-FLAT	
03H	BCT	TREB				Don't Care		

● CONTROL REGISTER DEFAULT VALUE

Control register default value is all "0".

Select Address	BIT							
	D7	D6	D5	D4	D3	D2	D1	D0
00H	0	0	0	0	0	0	0	0
01H	0	0	0	0	0	0	0	0
02H	0	0	0	0	0	0	0	0
03H	0	0	0	0	0	0	0	0

■ I²C CONTROL COMMAND DESCRIPTION

● MASTER VOLUME CONTROL

Select Address	BIT							
	D7	D6	D5	D4	D3	D2	D1	D0
00H	VOL							

The volume controls both Ach and Bch by the 0.5dB step.

The volume is consisted of volume1 and volume2. The level is divided into half to each volume1 and volume2.

● BALANCE, AGC AND INPUT SELECTOR SETTINGS

Select Address	BIT							
	D7	D6	D5	D4	D3	D2	D1	D0
01H	CHS	BAL					SUR	

- CHS: Channel select for balance control

“0”: Ach “Bch is attenuated”

“1”: Bch “Ach is attenuated”

- BAL: Balance control for both Ach and Bch (1dB/Step)

The balance is consisted of volume2 alone. Volume1 does not operate on balance.

- SUR : Surround Setting

Surround Setting	SUR		Remarks
	D1	D0	
Surround OFF	0	0	Input through
Simulated Stereo mode	0	1	For monaural signal input only
"eala" High mode	1	0	Surround Effect Small (8.0dB typ.)
"eala" Low mode	1	1	Surround Effect Large (12.0dB typ.)

● TONE CONTROL (Bass) and AGC SETTINGS

Select Address	BIT							
	D7	D6	D5	D4	D3	D2	D1	D0
02H	BCB	BASS				AGC-SW	AGC-FLAT	

- BCB : Bass Boost or Cut

“0” : Cut

“1” : Boost

- BASS : BASS Level

Cut Level : -15 to 0dB(1dB/Step)

Boost Level : 0 to +15dB(1dB/Step)

- AGC-SW : AGC ON/OFF Switch

“0” : AGC OFF

“1” : AGC ON (Default : 100mVrms)

- AGC-FLAT : AGC Flat Level

AGC Flat Level	AGC-FLAT	
	D1	D0
100mVrms	0	0
200mVrms	0	1
300mVrms	1	0
400mVrms	1	1

●TONE CONTROL (Treble) SETTINGS

Select Address	BIT							
	D7	D6	D5	D4	D3	D2	D1	D0
03H	BCT	TREB				Don't Care		

- BCT : Treble Boost or Cut
"0" : Cut
"1" : Boost
- TREB : Treble Level
Cut Level : -15 to 0dB(1dB/Step)

■ Master Volume (Select Address: 00H)

		VOL							
Gain(dB)	HEX	D7	D6	D5	D4	D3	D2	D1	D0
0	FF	1	1	1	1	1	1	1	1
-1	FD	1	1	1	1	1	1	0	1
-2	FB	1	1	1	1	1	0	1	1
-3	F9	1	1	1	1	1	0	0	1
-4	F7	1	1	1	1	0	1	1	1
-5	F5	1	1	1	1	0	1	0	1
-6	F3	1	1	1	1	0	0	1	1
-7	F1	1	1	1	1	0	0	0	1
-8	EF	1	1	1	0	1	1	1	1
-9	ED	1	1	1	0	1	1	0	1
-10	EB	1	1	1	0	1	0	1	1
-11	E9	1	1	1	0	1	0	0	1
-12	E7	1	1	1	0	0	1	1	1
-13	E5	1	1	1	0	0	1	0	1
-14	E3	1	1	1	0	0	0	1	1
-15	E1	1	1	1	0	0	0	0	1
-16	DF	1	1	0	1	1	1	1	1
-17	DD	1	1	0	1	1	1	0	1
-18	DB	1	1	0	1	1	0	1	1
-19	D9	1	1	0	1	1	0	0	1
-20	D7	1	1	0	1	0	1	1	1
-21	D5	1	1	0	1	0	1	0	1
-22	D3	1	1	0	1	0	0	1	1
-23	D1	1	1	0	1	0	0	0	1
-24	CF	1	1	0	0	1	1	1	1
-25	CD	1	1	0	0	1	1	0	1
-26	CB	1	1	0	0	1	0	1	1
-27	C9	1	1	0	0	1	0	0	1
-28	C7	1	1	0	0	0	1	1	1
-29	C5	1	1	0	0	0	1	0	1
-30	C3	1	1	0	0	0	0	1	1
-31	C1	1	1	0	0	0	0	0	1
-32	BF	1	0	1	1	1	1	1	1
-33	BD	1	0	1	1	1	1	0	1
-34	BB	1	0	1	1	1	0	1	1
-35	B9	1	0	1	1	1	0	0	1
-36	B7	1	0	1	1	0	1	1	1
-37	B5	1	0	1	1	0	1	0	1
-38	B3	1	0	1	1	0	0	1	1
-39	B1	1	0	1	1	0	0	0	1
-40	AF	1	0	1	0	1	1	1	1
-41	AD	1	0	1	0	1	1	0	1
-42	AB	1	0	1	0	1	0	1	1

■MASTER VOLUME (Cont'd)

Gain(dB)	HEX	VOL							
		D7	D6	D5	D4	D3	D2	D1	D0
-43	A9	1	0	1	0	1	0	0	1
-44	A7	1	0	1	0	0	1	1	1
-45	A5	1	0	1	0	0	1	0	1
-46	A3	1	0	1	0	0	0	1	1
-47	A1	1	0	1	0	0	0	0	1
-48	9F	1	0	0	1	1	1	1	1
-49	9D	1	0	0	1	1	1	0	1
-50	9B	1	0	0	1	1	0	1	1
-51	99	1	0	0	1	1	0	0	1
-52	97	1	0	0	1	0	1	1	1
-53	95	1	0	0	1	0	1	0	1
-54	93	1	0	0	1	0	0	1	1
-55	91	1	0	0	1	0	0	0	1
-56	8F	1	0	0	0	1	1	1	1
-57	8D	1	0	0	0	1	1	0	1
-58	8B	1	0	0	0	1	0	1	1
-59	89	1	0	0	0	1	0	0	1
-60	87	1	0	0	0	0	1	1	1
-61	85	1	0	0	0	0	1	0	1
-62	83	1	0	0	0	0	0	1	1
-63	81	1	0	0	0	0	0	0	1
-64	7F	0	1	1	1	1	1	1	1
-65	7D	0	1	1	1	1	1	0	1
-66	7B	0	1	1	1	1	0	1	1
-67	79	0	1	1	1	1	0	0	1
-68	77	0	1	1	1	0	1	1	1
-69	75	0	1	1	1	0	1	0	1
-70	73	0	1	1	1	0	0	1	1
-71	71	0	1	1	1	0	0	0	1
-72	6F	0	1	1	0	1	1	1	1
-73	6D	0	1	1	0	1	1	0	1
-74	6B	0	1	1	0	1	0	1	1
-75	69	0	1	1	0	1	0	0	1
-76	67	0	1	1	0	0	1	1	1
-77	65	0	1	1	0	0	1	0	1
-78	63	0	1	1	0	0	0	1	1
-79	61	0	1	1	0	0	0	0	1
-80	5F	0	1	0	1	1	1	1	1
⋮	⋮	⋮	⋮	⋮	⋮	⋮	⋮	⋮	⋮
⋮	⋮	⋮	⋮	⋮	⋮	⋮	⋮	⋮	⋮
-90	4B	0	1	0	0	1	0	1	1
⋮	⋮	⋮	⋮	⋮	⋮	⋮	⋮	⋮	⋮
⋮	⋮	⋮	⋮	⋮	⋮	⋮	⋮	⋮	⋮
-100	37	0	0	1	1	0	1	1	1
Mute	00	0	0	0	0	0	0	0	0

■ Balance (Select Address: 01H)

Channel Setting	CHS
	D7
Attenuated Bch Gain	0
Attenuated Ach Gain	1

Gain(dB)	BAL				
	D6	D5	D4	D3	D2
0	0	0	0	0	0
-1	0	0	0	0	1
-2	0	0	0	1	0
-3	0	0	0	1	1
-4	0	0	1	0	0
-5	0	0	1	0	1
-6	0	0	1	1	0
-7	0	0	1	1	1
-8	0	1	0	0	0
-9	0	1	0	0	1
-10	0	1	0	1	0
-11	0	1	0	1	1
-12	0	1	1	0	0
-13	0	1	1	0	1
-14	0	1	1	1	0
-15	0	1	1	1	1
-16	1	0	0	0	0
-17	1	0	0	0	1
-18	1	0	0	1	0
-19	1	0	0	1	1
-20	1	0	1	0	0
-21	1	0	1	0	1
-22	1	0	1	1	0
-23	1	0	1	1	1
-24	1	1	0	0	0
-25	1	1	0	0	1
-26	1	1	0	1	0
-27	1	1	0	1	1
-28	1	1	1	0	0
-29	1	1	1	0	1
-30	1	1	1	1	0
MUTE	1	1	1	1	1

■ Tone Control Bass (Select Address: 02H)

Bass Cut or Boost	BCB
	D7
Cut	0
Boost	1

		BASS			
Cut Gain(dB)	Boost Gain(dB)	D6	D5	D4	D3
-15	15	1	1	1	1
-14	14	1	1	1	0
-13	13	1	1	0	1
-12	12	1	1	0	0
-11	11	1	0	1	1
-10	10	1	0	1	0
-9	9	1	0	0	1
-8	8	1	0	0	0
-7	7	0	1	1	1
-6	6	0	1	1	0
-5	5	0	1	0	1
-4	4	0	1	0	0
-3	3	0	0	1	1
-2	2	0	0	1	0
-1	1	0	0	0	1
0	0	0	0	0	0

■ Tone Control Treble (Select Address: 03H)

Treble Cut or Boost	BCT
	D7
Cut	0
Boost	1

		TREB			
Cut Gain(dB)	Boost Gain(dB)	D6	D5	D4	D3
-15	15	1	1	1	1
-14	14	1	1	1	0
-13	13	1	1	0	1
-12	12	1	1	0	0
-11	11	1	0	1	1
-10	10	1	0	1	0
-9	9	1	0	0	1
-8	8	1	0	0	0
-7	7	0	1	1	1
-6	6	0	1	1	0
-5	5	0	1	0	1
-4	4	0	1	0	0
-3	3	0	0	1	1
-2	2	0	0	1	0
-1	1	0	0	0	1
0	0	0	0	0	0

[CAUTION]
The specifications on this databook are only given for information, without any guarantee as regards either mistakes or omissions. The application circuits in this databook are described only to show representative usages of the product and not intended for the guarantee or permission of any right including the industrial rights.