

C-MOS COMPARATOR WITH C-MOS OUTPUT

■ GENERAL DESCRIPTION

The NJU7102A and 04A dual and quad C-MOS Comparators performing wide operating voltage from 3 to 14V, low operating current and low offset voltage.

The NJU7102A and 04A operated on a single-power-supply can interface with most of TTL and C-MOS type standard logic ICs.

■ FEATURES

- Single-Power-Supply
- Wide Operating Voltage ($V_{DD}=3\sim 14V$)
- Low Operating Current ($9\mu A/\text{circuit typ.}$)
- Wide Common Mode Input Voltage ($0\sim 3.8V @ V_{DD}=5V$)
- High Input Impedance
- Low Bias Current ($I_B=1pA$)
- Low Offset Voltage
- C-MOS (Push-Pull) Output
- Package Outline
DIP/DMP8 (NJU7102A)
DIP/DMP14 (NJU7104A)
- C-MOS Technology

■ PACKAGE OUTLINE

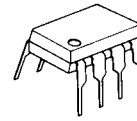

NJU7102AD

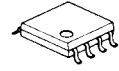

NJU7102AM

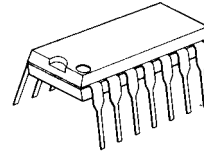

NJU7104AD

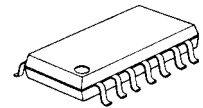

NJU7104AM

■ PIN CONFIGURATION

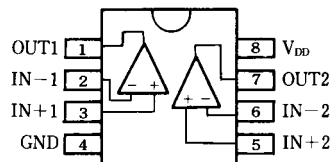

NJU7102AD/AM

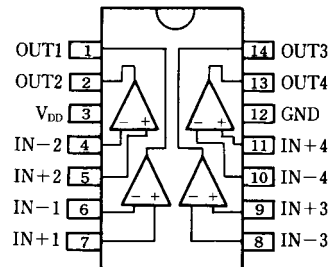

NJU7104AD/AM

■ EQUIVALENT CIRCUIT

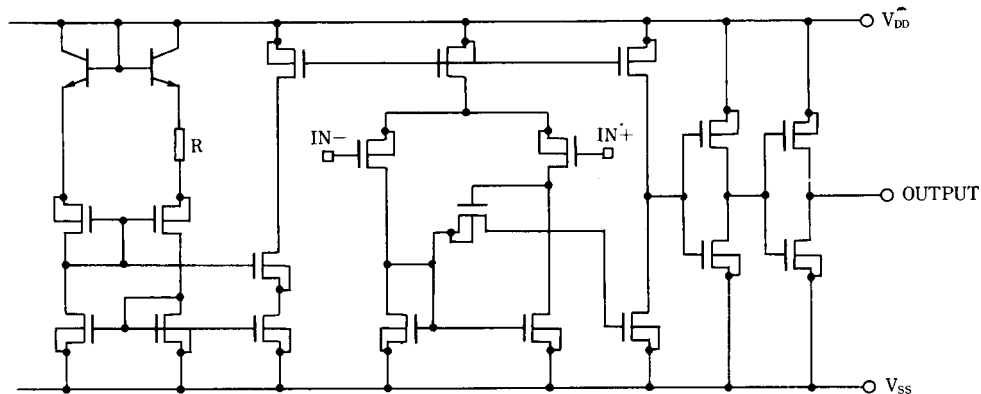

NJU7102A/04A

■ ABSOLUTE MAXIMUM RATINGS

(Ta=25°C)

PARAMETER	SYMBOL	RATINGS	UNIT
Supply Voltage	V _{DD}	16	V
Differential Input Voltage	V _{ID}	± 16 (note1)	V
Input Voltage	V _{IC}	16	V
Output Voltage	V _O	16	V
Output Current	I _O	20	mA
Power Dissipation	P _D	(DIP8) 500 (DIP14) 700 (DMP8) 300 (DMP14) 300	mW
Operating Temperature Range	T _{opr}	0~+70	°C
Storage Temperature Range	T _{stg}	-40~+125	°C

(note1) If the supply voltage (V_{DD}) is less than 16V, the input voltage must not over the V_{DD} level though 16V is limit specified.

■ ELECTRICAL CHARACTERISTICS

(Ta=25°C, V_{DD}=5V)

PARAMETER	SYMBOL	TEST CONDITION	NJU7102A			NJU7104A			UNIT
			MIN.	TYP.	MAX.	MIN.	TYP.	MAX.	
Operating Voltage	V _{DD}		3	-	14	3	-	14	V
Input Offset Voltage	V _{IO}	V _{IC} =V _{ICmin} (note2)	-	1.2	12	-	1.2	12	mV
Input Offset Current	I _{IO}		-	1	-	-	1	-	pA
Input Bias Current	I _B		-	1	-	-	1	-	pA
Input Common Mode Voltage Range	V _{ICM}		0	-	3.8	0	-	3.8	V
Output Voltage	V _{OH}	V _{ID} =+1V, I _{OH} =+5V	4.5	4.7	-	4.5	4.7	-	V
	V _{OL}	V _{ID} =+1V, I _{OL} =+6mA	-	0.22	0.30	-	0.234	0.30	V
Common Mode Rejection Ratio	CMR	V _{IC} =V _{ICmin}	-	82	-	-	78	-	dB
Supply Voltage Rejection Ratio	SVR	V _{DD} =5~10V	-	90	-	-	92	-	dB
Operating Current	I _{DD}	No Load, V _O =0V	-	18	40	-	36	80	μA

(note2) This condition is available for operating voltage V_{DD}=5~10V and driving voltage is over 4.5V or under 0.3V.

■ SWITCHING CHARACTERISTICS

(Ta=25°C, V_{DD}=5V, f=10kHz, C_L=15pF)

PARAMETER	SYMBOL	CONDITIONS	NJU7102A			NJU7104A			UNIT	
			MIN	TYP	MAX	MIN	TYP	MAX		
Propagation Delay High to Low	t _{PHL}	V _{IC} =0V	Over Drive=5mV	-	3.0	-	-	2.3	-	μs
			TTL level step	-	0.17	-	-	0.17	-	
Propagation Delay Low to High	t _{PLH}	V _{IC} =0V	Over Drive=5mV	-	1.9	-	-	1.3	-	μs
			TTL level step	-	0.8	-	-	0.8	-	
Output Signal Falling Time	t _{FHL}	Over Drive=50mV	-	30	-	-	30	-	ns	
Output Signal Rising Time	t _{FHL}	Over Drive=50mV	-	70	-	-	70	-	ns	

■ MEASUREMENT CIRCUIT

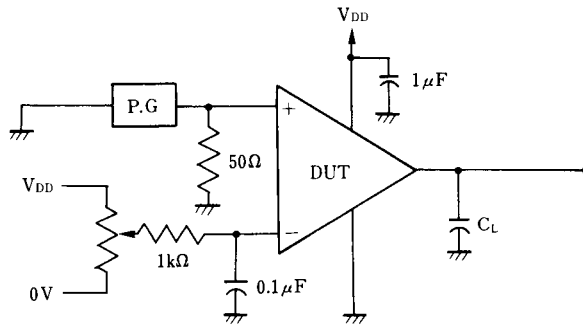

■ TIMING WAVEFORM

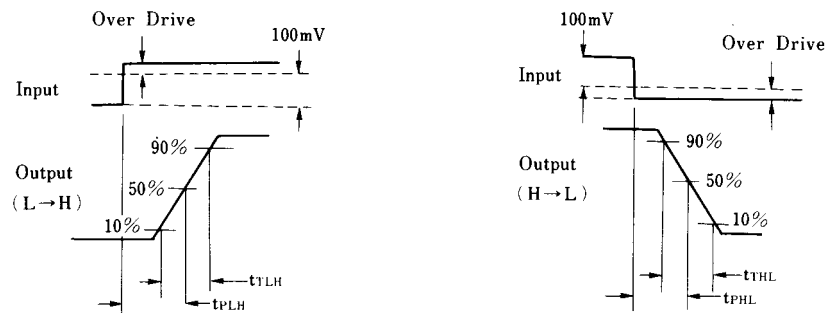

[CAUTION]

The specifications on this databook are only given for information, without any guarantee as regards either mistakes or omissions. The application circuits in this databook are described only to show representative usages of the product and not intended for the guarantee or permission of any right including the industrial rights.