



Product Preview

Dual-Band CDMA Upconverter

The MRFIC1884 is an integrated upmixer, RF AGC amplifier and driver amplifier designed for dual-band, tri-mode CDMA/AMPS/PCS CDMA cellular radios. The device incorporates a temperature compensated linear gain control and an active bias control that reduces supply current at lower output power. The design utilizes Motorola's RF BiCMOS process and is packaged in a small cost effective BCC32++ package.

- Designed for Dual-Band, Tri-Mode Operation
 - Total Supply Current CDMA/PCS CDMA Mode = 60 mA (Typ)
 - Total Supply Current AMPS Mode = 42 mA (Typ)
- High Output Power
 - 6.0 dBm for CDMA
 - 6.0 dBm for PCS CDMA
 - 11 dBm for AMPS
- Supply Voltage Range: 2.7 to 3.2 V

MRFIC1884

DUAL-BAND CDMA UPCONVERTER

SEMICONDUCTOR TECHNICAL DATA

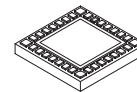

(Scale 2:1)

PLASTIC PACKAGE
CASE 1261A
(BCC32++)

ORDERING INFORMATION

Device	Operating Temp Range	Package
MRFIC1884R2	T _A = -40 to 85°C	BCC32++

Simplified Block Diagram and Pin Connections

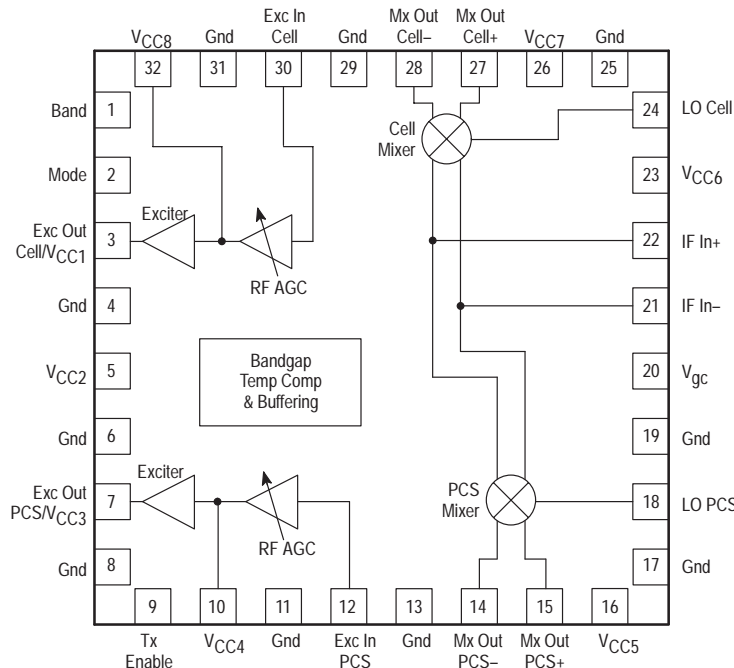

Bump Chip Carrier++ (BCC++) is a trademark of Fujitsu Microelectronics, Inc.

MRFIC1884

PIN FUNCTION DESCRIPTION

Pin	Function	Description	Voltage On (V)	Voltage Off (V)
1	Band	Band Selection pin. A logic "High" (>2.4 V) selects PCS band and "Low" (<0.4 V) selects Cellular band.	2.4 to 3.2	0 to 0.4
2	Mode	Mode selection pin. A logic "High" (>2.4 V) selects CDMA band and "Low" (<0.4 V) selects AMPS band.	2.4 to 3.2	0 to 0.4
3	Exciter Out (Cellular)/ VCC1	Cellular band RF Exciter output pin.	2.7 to 3.2	
4	Gnd	Ground connection.	–	
5	VCC2	Supply Voltage.	2.7 to 3.2	
6	Gnd	Ground connection.	–	
7	Exciter Out (PCS)/ VCC3	PCS band RF Exciter output pin.	2.7 to 3.2	
8	Gnd	Ground connection.	–	
9	Tx Enable	Tx Enable pin. A logic "High" (>2.4 V) enables Tx path and "Low" (<0.4 V) disables Tx path except LO Buffer and bandgap reference (will disable the entire chip complete with Band selection pin and Mode selection pin, refer to Table ?).	2.4 to 3.2	0 to 0.4
10	VCC4	Supply Voltage.	2.7 to 3.2	
11	Gnd	Ground connection.	–	
12	Exciter In (PCS)	PCS band RF Exciter input pin.	–	
13	Gnd	Ground connection.	–	
14	Mixer Out– (PCS)	PCS band Mixer RF output pin.	2.7 to 3.2	
15	Mixer Out+ (PCS)	PCS band Mixer RF output pin.	2.7 to 3.2	
16	VCC5	Supply Voltage.	2.7 to 3.2	
17	Gnd	Ground connection.	–	
18	LO (PCS)	PCS band Mixer LO input pin.	–12 dBm (Typ)	
19	Gnd	Ground connection.	–	
20	V _{gc}	RF AGC control pin. A 30 dB dynamic range can be achieved by adjusting voltage from 0.1 V (low gain) to 1.7 V (high gain).	0.1 to 1.7	
21	IF In–	Mixer IF input pin.	–23 dBm (Typ)	
22	IF In+	Mixer IF input pin.	–23 dBm (Typ)	
23	VCC6	Supply Voltage.	2.7 to 3.2	
24	LO (Cellular)	Cellular band Mixer LO input pin.	–13 dBm (Typ)	
25	Gnd	Ground connection.	–	
26	VCC7	Supply Voltage.	2.7 to 3.2	
27	Mixer Out+ (Cellular)	Cellular band Mixer RF output pin.	2.7 to 3.2	
28	Mixer Out– (Cellular)	Cellular band Mixer RF output pin.	2.7 to 3.2	
29	Gnd	Ground connection.	–	
30	Exciter In (Cellular)	Cellular band RF Exciter input pin.	–	
31	Gnd	Ground connection.	–	
32	VCC8	Supply Voltage.	2.7 to 3.2	

MRFIC1884
NOTES

MRFIC1884

OUTLINE DIMENSIONS

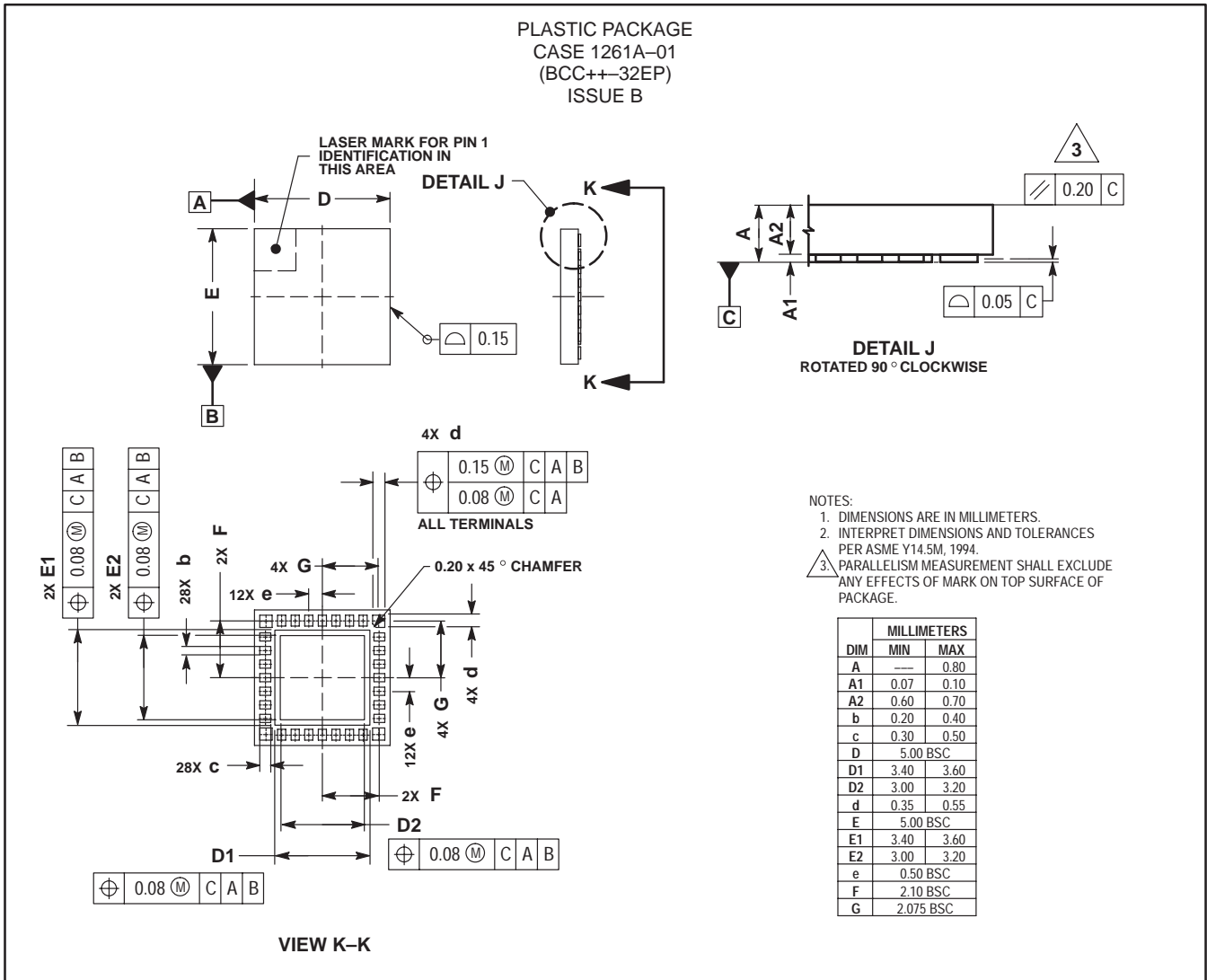

Motorola reserves the right to make changes without further notice to any products herein. Motorola makes no warranty, representation or guarantee regarding the suitability of its products for any particular purpose, nor does Motorola assume any liability arising out of the application or use of any product or circuit, and specifically disclaims any and all liability, including without limitation consequential or incidental damages. "Typical" parameters which may be provided in Motorola data sheets and/or specifications can and do vary in different applications and actual performance may vary over time. All operating parameters, including "Typicals" must be validated for each customer application by customer's technical experts. Motorola does not convey any license under its patent rights nor the rights of others. Motorola products are not designed, intended, or authorized for use as components in systems intended for surgical implant into the body, or other applications intended to support or sustain life, or for any other application in which the failure of the Motorola product could create a situation where personal injury or death may occur. Should Buyer purchase or use Motorola products for any such unintended or unauthorized application, Buyer shall indemnify and hold Motorola and its officers, employees, subsidiaries, affiliates, and distributors harmless against all claims, costs, damages, and expenses, and reasonable attorney fees arising out of, directly or indirectly, any claim of personal injury or death associated with such unintended or unauthorized use, even if such claim alleges that Motorola was negligent regarding the design or manufacture of the part. Motorola and are registered trademarks of Motorola, Inc. Motorola, Inc. is an Equal Opportunity/Affirmative Action Employer.

How to reach us:

USA/EUROPE/Locations Not Listed: Motorola Literature Distribution;
P.O. Box 5405, Denver, Colorado 80217. 1-303-675-2140 or 1-800-441-2447

JAPAN: Motorola Japan Ltd.; SPS, Technical Information Center, 3-20-1,
Minami-Azabu, Minato-ku, Tokyo 106-8573 Japan. 81-3-3440-3569

Technical Information Center: 1-800-521-6274

ASIA/PACIFIC: Motorola Semiconductors H.K. Ltd.; Silicon Harbour Centre,
2, Dai King Street, Tai Po Industrial Estate, Tai Po, N.T., Hong Kong.
852-26668334

HOME PAGE: <http://www.motorola.com/semiconductors/>

