



The Future of Analog IC Technology™

MP1519

1x, 1.5x, 2x High Efficiency Charge Pump 4 White LED Driver

DESCRIPTION

The MP1519 is a fully automatic driver for powering four white LEDs, with up to 4V forward voltage, from a single Li-Ion or three NiMH cells. The driver performs all of the sensing and control to run the LEDs at an optimum charge pump ratio for efficiency without an expensive inductor. The driver allows PWM operation to support brightness control.

The tiny 3mm x 3mm QFN16 package and small external capacitors allow for the most compact white LED solution available.

EVALUATION BOARD REFERENCE

Board Number	Dimensions
EV0042	2.4"X x 1.9"Y x 0.4"Z

FEATURES

- 2% LED Current Matching
- High Efficiency (>93%)
- Current Source Outputs
- No Ballast Resistors Required
- 1x, 1.5x and 2x Automatic Modes
- Constant Frequency Operation
- Automatic LED Detection
- High and Low Frequency PWM Capability
- 2.5V to 5.5V Operation
- Less than 1µA Leakage during Shutdown
- Detects Changes in Battery Level
- No External Schottky Diode Required
- Soft-Start and Soft Switching Operation

APPLICATIONS

- Cell Phones
- PDA or Hand Held Computers
- White LED Application at 3.6V Supply

"MPS" and "The Future of Analog IC Technology" are Trademarks of Monolithic Power Systems, Inc.

TYPICAL APPLICATION

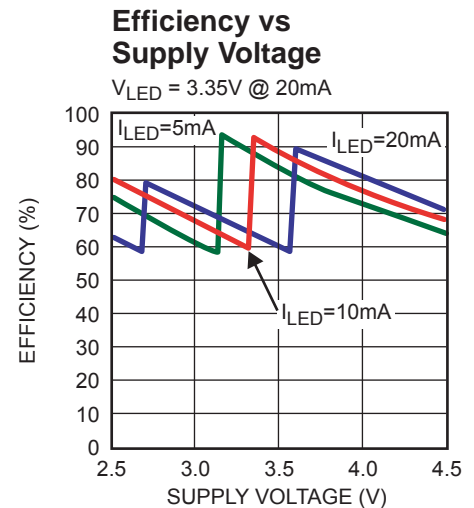
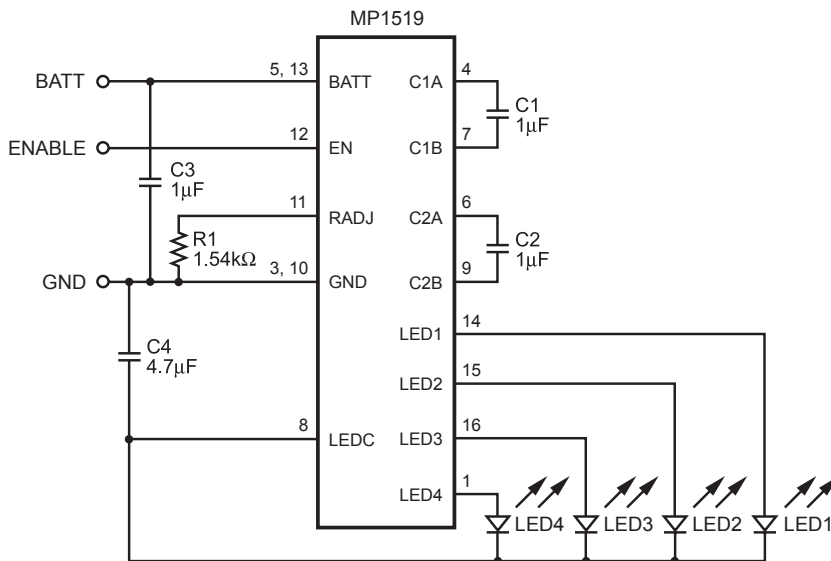

PACKAGE REFERENCE

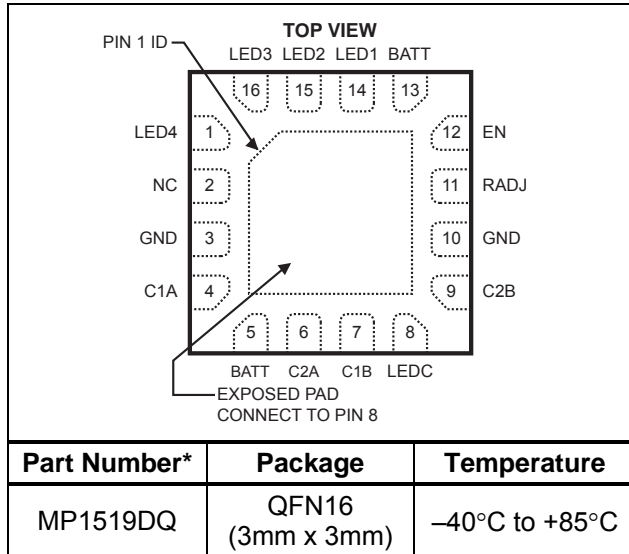

* For Tape & Reel, add suffix -Z (eg. MP1519DQ-Z)
 For RoHS Compliant Packaging, add suffix -LF
 (eg. MP1519DQ-LF-Z)

ABSOLUTE MAXIMUM RATINGS ⁽¹⁾

V_{BATT} to GND 6.5V
 Power Dissipation (QFN)..... 1.0W
 Logic Inputs to GND -0.3V to +6.5V
 Storage Temperature -65°C to +150°C
 Junction Temperature..... 150°C

Recommended Operating Conditions ⁽²⁾

Input Voltage V_{BATT} 2.5V to 5.5V
 Operating Temperature -40°C to +85°C

Thermal Resistance ⁽³⁾ θ_{JA} θ_{JC}
 3x3 QFN16 60 14... °C/W

Notes:

- Exceeding these ratings may damage the device.
- The device is not guaranteed to function outside of its operating conditions.
- Measured on approximately 1" square of 1 oz copper.

ELECTRICAL CHARACTERISTICS

$V_{BATT} = 5V$, $T_A = +25^\circ C$, unless otherwise noted.

Parameter	Symbol	Condition	Min	Typ	Max	Units
Input Supply Voltage	V_{BATT}		2.5		5.5	V
V_{BATT} at 1x to 1.5x Mode Switch	$V_{BATT\ 1x-1.5x}$	$I_{LED} = 20mA$, V_{BATT} Decreasing, $V_{LED} = 3.35V @ 20mA$		3.6		V
V_{BATT} at 1.5x to 2x Mode Switch	$V_{BATT\ 1.5x-2x}$	$I_{LED} = 20mA$, V_{BATT} Decreasing, $V_{LED} = 3.35V @ 20mA$		2.8		V
V_{BATT} at 2x to 1.5x Mode Switch	$V_{BATT\ 2x-1.5x}$	V_{BATT} Increasing, $V_{LED} = 3.35V @ 20mA$		3.1		V
V_{BATT} at 1.5x to 1x Mode Switch	$V_{BATT\ 1.5x-1x}$	V_{BATT} Increasing, $V_{LED} = 3.35V @ 20mA$		3.8		V
Supply Current	I_{BATT}	4 LEDs at 20mA, 2x Mode, $V_{BATT} = 2.5V$		164	180	mA
Supply Current Shutdown	$I_{BATT\ SHDN}$	$V_{EN} = 0V$		0.1	1	μA
Current Matching ⁽⁴⁾	$I_{LED\ MATCH}$	$I_{LED} = 20mA$		1.5	5.0	%
Enable Voltage, High	$V_{EN(HIGH)}$			2.0	2.2	V
Enable Voltage, Low	$V_{EN(LOW)}$		0.8	1.0		V
Enable Pin Leakage	I_{EN}	$V_{EN} = 5V$		0.1	1	μA
Charge Pump Frequency	F_{CP}	$V_{BATT} = 3.3V$	1.0	1.3	1.6	MHz
Time to Standby Mode ⁽⁵⁾	T_{OFF}	Enable Switched Low		30		μs
Enable Pin PWM Frequency Limit	F_{HPWM}			50		KHz
LED Current	I_{LED}	$R_{SET} = 1.54k\Omega$	18	20	22	mA

Notes:

- Matching is defined as the difference of the maximum to minimum current divided by the sum of the maximum and minimum currents.
- Standby mode switches to shutdown when the output voltage on LEDC drifts back to GND.

TYPICAL PERFORMANCE CHARACTERISTICS

Voltage Ripple in 1.5x Mode

4 x 10mA LEDs

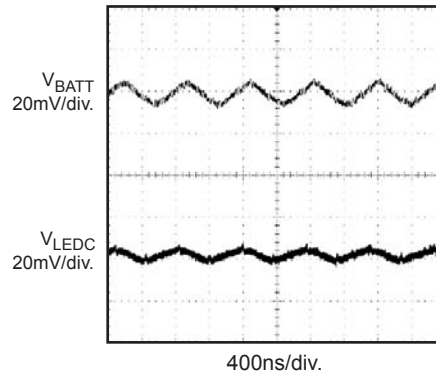

Startup in 1.5x Mode

4 x 10mA LEDs

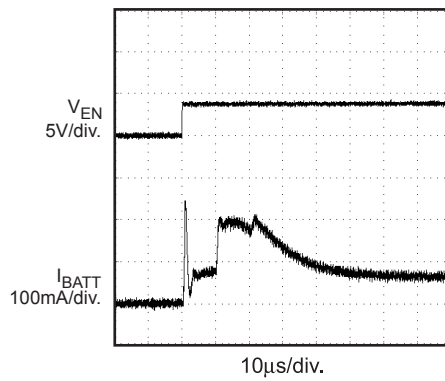

Startup in 1x Mode

4 x 10mA LEDs

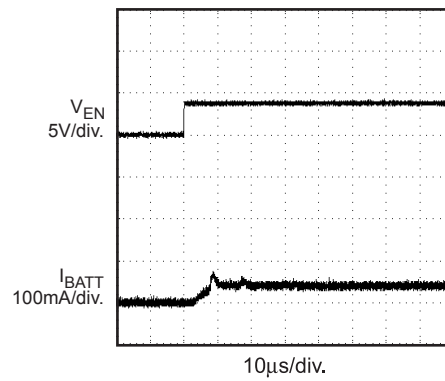

Analog Dimming

Circuit of Figure 3, $V_{BATT} = 3.6V$

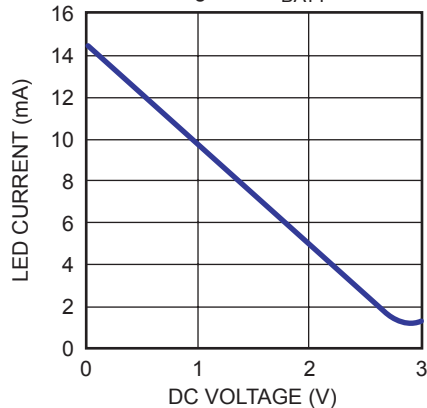

LED Current Matching

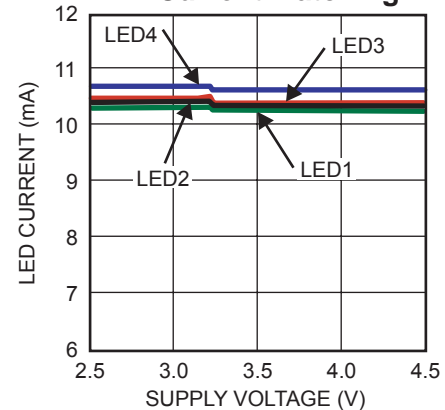

PIN FUNCTIONS

Pin #	Name	Description
1	LED4	#4 LED Driver. Connect the #4 LED between LED4 and LEDC, with the anode at LED4, and the cathode at LEDC. If the #4 LED is not used, leave LED4 unconnected.
2	NC	No Connect.
3, 10	GND	Ground.
4	C1A	Charge Pump Capacitor #1 Positive Node. Connect the positive side of the #1 charge pump capacitor to C1A. Typical applications require C1 to be 1 μ F.
5, 13	BATT	Battery Power Input. Connect the 2.5V to 5.5V input source between BATT and GND. Bypass BATT to GND with a 1 μ F or greater capacitor.
6	C2A	Charge Pump Capacitor #2 Positive Node. Connect the positive side of the #2 charge pump capacitor to C2A. Typical applications require C2 to be 1 μ F.
7	C1B	Charge Pump Capacitor #1 Negative Node. Connect the negative side of the #1 charge pump capacitor to C1B.
8	LEDC	LED Common for the Cathodes. Connect the cathodes of the LEDs to LEDC and to a 4.7 μ F bypass capacitor. Do not connect to any other ground, supply or pin. Note: Exposed pad on backside is connected to this pin. Do Not Ground.
9	C2B	Charge Pump Capacitor #2 Negative Node. Connect the negative side of the #2 charge pump capacitor to C2B.
11	RADJ	LED Current Adjust Input. Connect a resistor between RADJ and GND to set the LED current. All of the LEDs regulate at the same current. See <i>Setting the LED Current</i> .
12	EN	Enable Input. Drive EN high to turn on the MP1519, drive EN low to shutdown the MP1519. To use burst-mode brightness control, drive EN with a PWM signal. See <i>Burst Mode Dimming</i> .
14	LED1	#1 LED Driver. Connect the #1 LED between LED1 and LEDC, with the anode at LED1, and the cathode at LEDC. If the #1 LED is not used, leave LED1 unconnected.
15	LED2	#2 LED Driver. Connect the #2 LED between LED2 and LEDC, with the anode at LED2, and the cathode at LEDC. If the #2 LED is not used, leave LED2 unconnected.
16	LED3	#3 LED Driver. Connect the #3 LED between LED3 and LEDC, with the anode at LED3, and the cathode at LEDC. If the #3 LED is not used, leave LED3 unconnected.

OPERATION

The MP1519 is a charge pump that drives 4 LEDs from a 2.5V to 5.5V input voltage. It automatically switches between 1x, 1.5x and 2x charge pump modes to optimize efficiency while maintaining LED current regulation.

Four drivers independently regulate the current through the LEDs, therefore matching LEDs are not required.

The MP1519 employs soft switching and soft-start to prevent overloading the battery source at turn-on and charge pump mode switching.

While operating, the MP1519 continually monitors the LED current and battery voltage and automatically switches between charge pump modes to retain LED current regulation through all LEDs as the battery voltage fluctuates.

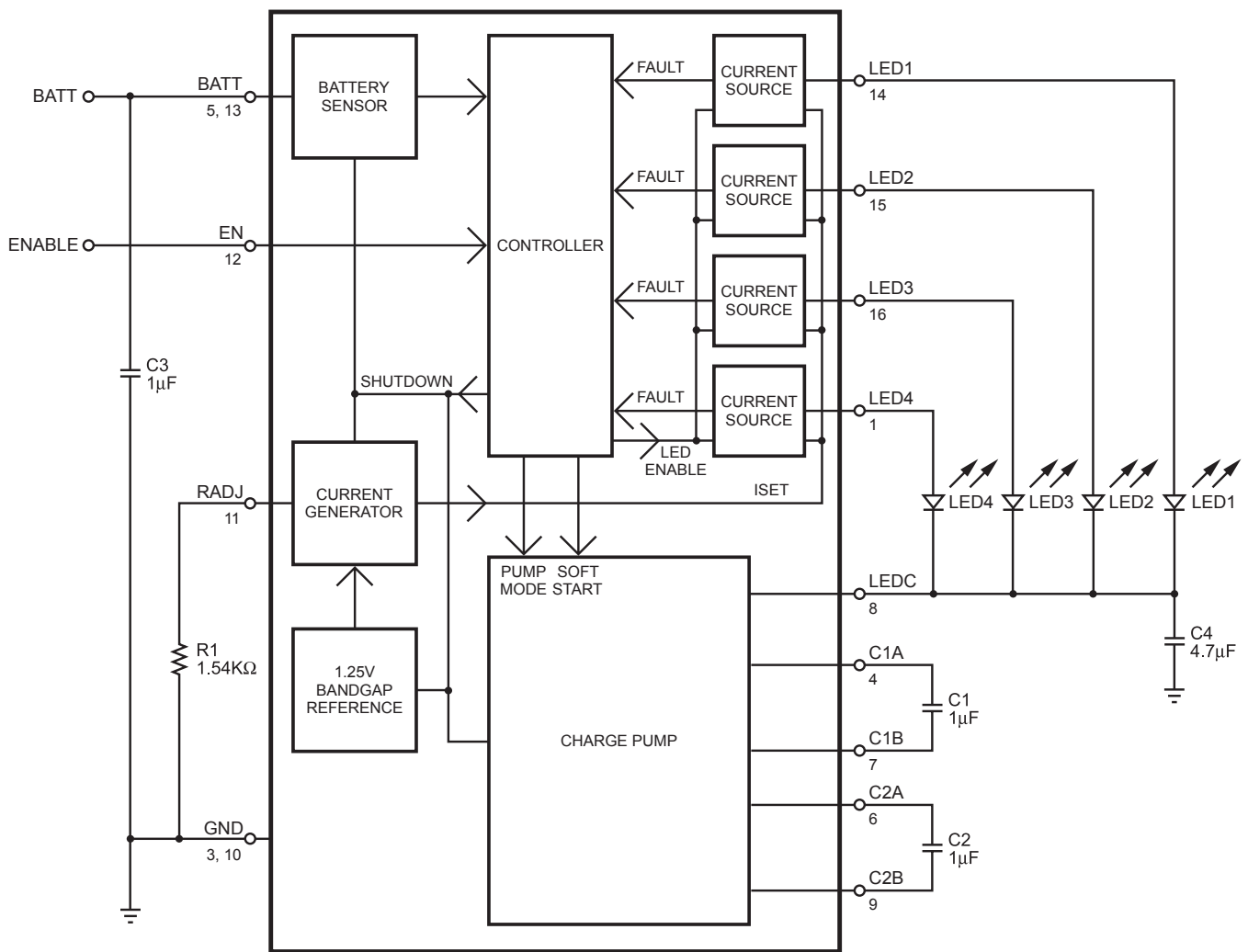

Figure 1—Functional Block Diagram

APPLICATION INFORMATION

COMPONENT SELECTION

Startup

When power is applied to the BATT, driving EN high will enable the MP1519. The MP1519 begins by checking for open LEDs and determining the optimum charge pump mode. The lowest charge pump mode that allows the programmed LED current in all LEDs is set. This will occur during initial turn-on or during analog mode and burst mode dimming.

Shutdown

Driving EN low for more than 30µs will disable the MP1519. For safety the MP1519 runs a small supervisory circuit in standby to protect the charge pump output LEDC. The circuit shuts down when the charge pump output returns to zero volts (this can take a few seconds). The MP1519 is in true shutdown mode when LEDC is zero and the 30µs time interval has passed. The supply current should be less than 1µA.

Setting the LED Current

The LED regulation current is set through the resistor R1 (refer to the typical application circuit on page 1). The voltage across R1 is fixed at 1.25V, and the current through that resistor sets the current through the LEDs.

Figure 2 shows LED Current (I_{LED}) vs. R1 with $V_{BATT} = 3.6V$.

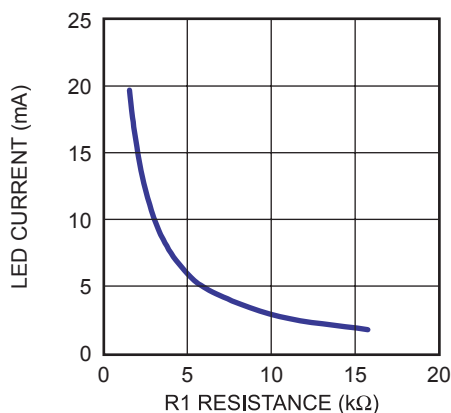

Figure 2— I_{LED} vs. R1

Choose R1 for the desired LED current according to the equation:

$$R1 = \frac{31.25}{I_{LED}}$$

Where R1 is in kΩ, and I_{LED} is in mA. Suitable values for R1 are greater than 1.2kΩ.

Soft-Start

During startup and mode switching, an internal soft-start prevents excessive input current, preventing excessive loading of the battery or input power source.

Burst Mode Dimming

To dim the part using burst mode, drive EN with a PWM signal. Each time EN is driven high, the MP1519 goes through the initial startup routine and checks for open LEDs, and the charge pump step-up mode is reset.

When EN goes low, the LED current immediately goes to zero. After EN is held low for 30µs or longer, and LEDC falls below GND, the MP1519 operating current drops below 1µA to improve battery life. Maintain the frequency of the PWM signal between 50Hz and 50KHz. Going above 50KHz the accuracy of the PWM signal will be degraded due to the startup time, and below 50Hz, the LED flicker will be evident to the eye.

Ideally, the LED current increases proportionally with the duty cycle of the PWM signal and is independent of the dimming frequency.

Analog Mode Dimming

Analog dimming can be accomplished with the circuit in Figure 3. The circuit provides 1mA to 15mA dimming with $V_{DC} = 0$ to 3V. The minimum LED current the MP1519 can regulate is approximately 1mA.

LEDC

Do not drive or force LEDC as it may be shorted to ground or may be pumped down by the controller in the MP1519 at any time. Excessive capacitance on the LEDC node can cause the internal controller to time out before the charge pump can be ready. Missing the timeouts will cause excessive pumping and a loss of efficiency. The MP1519 requires C1 and C2 be of the same value and type.

TYPICAL APPLICATION CIRCUITS

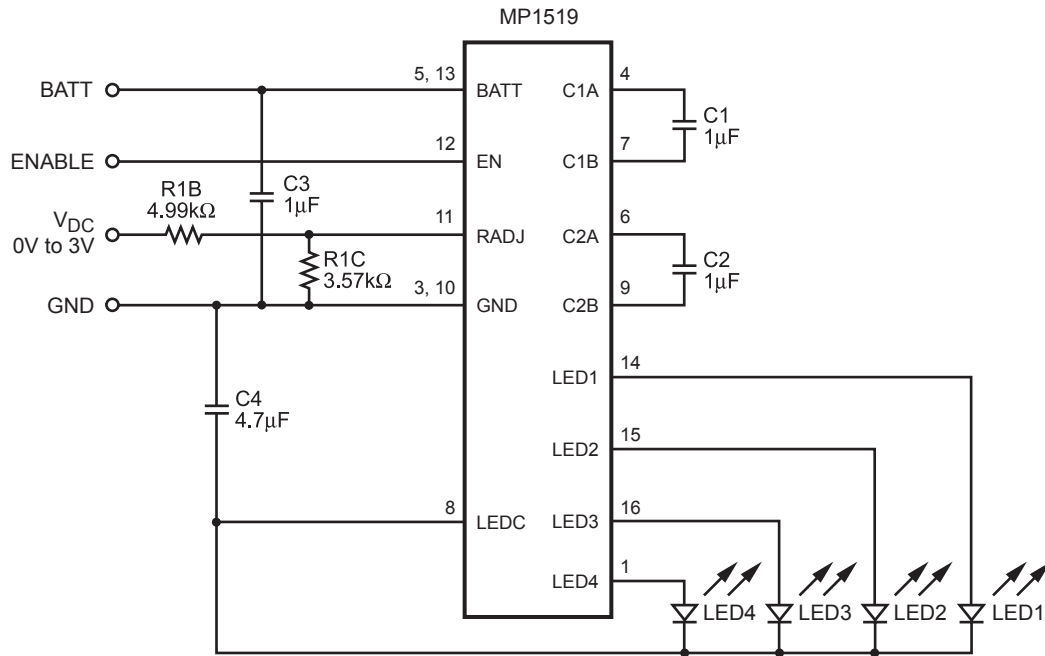
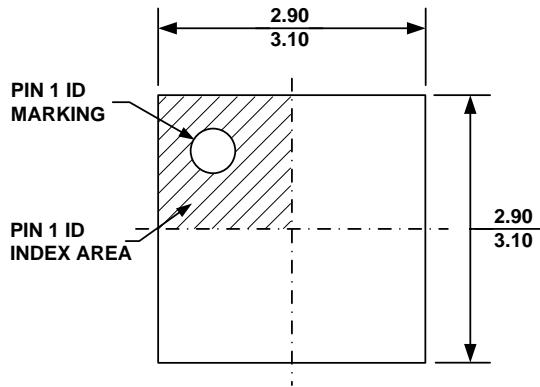

Figure 3—Analog Dimming Circuit

PACKAGE INFORMATION

QFN16 (3mm x 3mm)



TOP VIEW

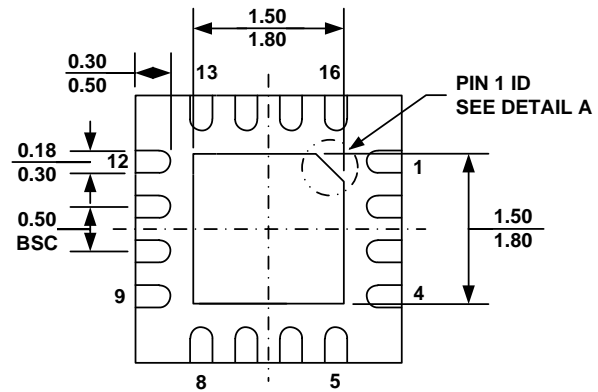

BOTTOM VIEW

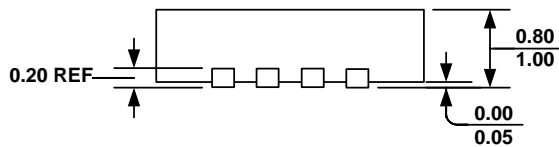

SIDE VIEW

PIN 1 ID OPTION A
0.30x45° TYP.

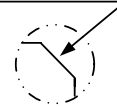

PIN 1 ID OPTION B
R0.20 TYP.

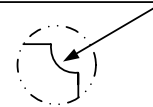

DETAIL A

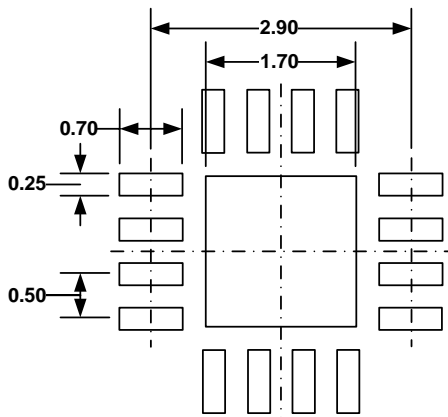

RECOMMENDED LAND PATTERN

NOTE:

- 1) ALL DIMENSIONS ARE IN MILLIMETERS.
- 2) EXPOSED PADDLE SIZE DOES NOT INCLUDE MOLD FLASH.
- 3) LEAD COPLANARITY SHALL BE 0.10 MILLIMETER MAX.
- 4) DRAWING CONFORMS TO JEDEC MO-220, VARIATION VEED-4.
- 5) DRAWING IS NOT TO SCALE.

NOTICE: The information in this document is subject to change without notice. Users should warrant and guarantee that third party Intellectual Property rights are not infringed upon when integrating MPS products into any application. MPS will not assume any legal responsibility for any said applications.