



# MMBTA42/43

## NPN SILICON TRANSISTOR

### HIGH VOLTAGE TRANSISTOR

■ DESCRIPTION

The UTC **MMBTA42/43** are high voltage transistors, designed for telephone switch and high voltage switch.

■ FEATURES

- \* Collector-Emitter voltage:  $V_{CE0}=300V$ (MMBTA42)
- \* Collector-Emitter voltage:  $V_{CE0}=200V$ (MMBTA43)
- \* High current gain
- \* Collector Dissipation:  $P_{C(max)}=350mW$

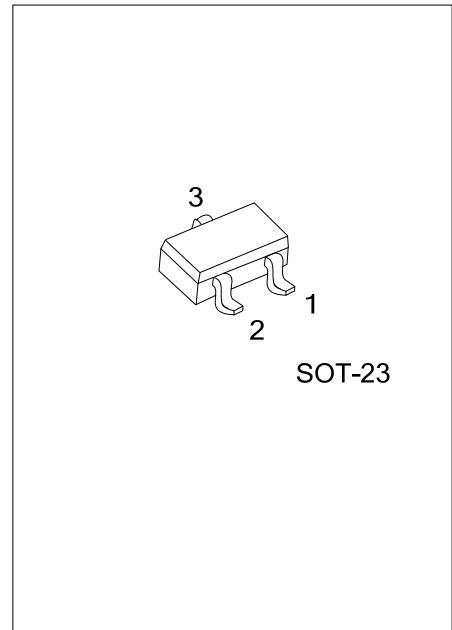

■ ORDERING INFORMATION

Ordering Number		Package	Pin Assignment			Packing
Lead Free	Halogen Free		1	2	3	
MMBTA42L-AE3-R	MMBTA42G-AE3-R	SOT-23	E	B	C	Tape Reel
MMBTA43L-AE3-R	MMBTA43G-AE3-R	SOT-23	E	B	C	Tape Reel

<p>MMBTA42L-AE3-R</p> <p>(1) Packing Type (2) Package Type (3) Lead Plating</p>	<p>(1) R: Tape Reel (2) AE3: SOT-23 (3) G: Halogen Free, L: Lead Free, Blank: Pb/Sn</p>
-----------------------------------------------------------------------------------------	-------------------------------------------------------------------------------------------------

■ MARKING

MMBTA42	MMBTA43
<p>L: Lead Free G: Halogen Free</p>	<p>L: Lead Free G: Halogen Free</p>

# MMBTA42/43

## NPN SILICON TRANSISTOR

### ■ ABSOLUTE MAXIMUM RATINGS (Ta=25°C)

PARAMETER	SYMBOL	RATINGS	UNIT
Collector-Base Voltage	MMBTA42	300	V
	MMBTA43	200	
Collector-Emitter Voltage	MMBTA42	300	V
	MMBTA43	200	
Emitter-Base Voltage	V <sub>EBO</sub>	6	V
Collector Dissipation (Ta=25°C)	P <sub>C</sub>	350	mW
Collector Current	I <sub>C</sub>	500	mA
Junction Temperature	T <sub>J</sub>	+150	°C
Storage Temperature	T <sub>STG</sub>	-55 ~ +150	°C

Note: Absolute maximum ratings are those values beyond which the device could be permanently damaged. Absolute maximum ratings are stress ratings only and functional device operation is not implied

### ■ ELECTRICAL CHARACTERISTICS (T<sub>J</sub>=25°C, unless otherwise specified)

PARAMETER	SYMBOL	TEST CONDITIONS	MIN	TYP	MAX	UNIT
Collector-Base Breakdown Voltage	MMBTA42	I <sub>C</sub> =100μA, I <sub>E</sub> =0	300			V
	MMBTA43		200			
Collector-Emitter Breakdown Voltage	MMBTA42	I <sub>C</sub> =1mA, I <sub>B</sub> =0	300			V
	MMBTA43		200			
Emitter-Base Breakdown Voltage	BV <sub>EBO</sub>	I <sub>E</sub> =100μA, I <sub>C</sub> =0	6			V
Collector-Emitter Saturation Voltage	V <sub>CE(SAT)</sub>	I <sub>C</sub> =20mA, I <sub>B</sub> =2mA			0.2	V
Base-Emitter Saturation Voltage	V <sub>BE(SAT)</sub>	I <sub>C</sub> =20mA, I <sub>B</sub> =2mA			0.90	V
Collector Cut-Off Current	MMBTA42	V <sub>CB</sub> =200V, I <sub>E</sub> =0			100	nA
	MMBTA43		V <sub>CB</sub> =160V, I <sub>E</sub> =0			
Emitter Cut-Off Current	MMBTA42	V <sub>EB</sub> =6V, I <sub>C</sub> =0			100	nA
	MMBTA43		V <sub>EB</sub> =4V, I <sub>C</sub> =0			
DC Current Gain	h <sub>FE</sub>	V <sub>CE</sub> =10V, I <sub>C</sub> =1mA	80			
		V <sub>CE</sub> =10V, I <sub>C</sub> =10mA	80		300	
		V <sub>CE</sub> =10V, I <sub>C</sub> =30mA	80			
Current Gain Bandwidth Product	f <sub>T</sub>	V <sub>CE</sub> =20V, I <sub>C</sub> =10mA f=100MHz	50			MHz
Collector Base Capacitance	MMBTA42	V <sub>CB</sub> =20V, I <sub>E</sub> =0, f=1MHz			3	pF
	MMBTA43				4	

## TYPICAL CHARACTERISTICS

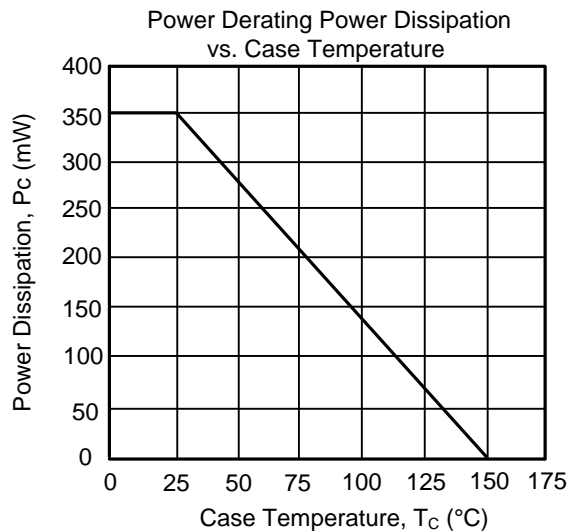
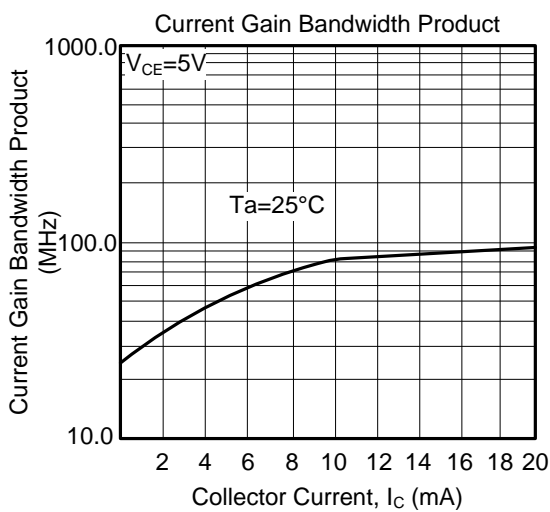
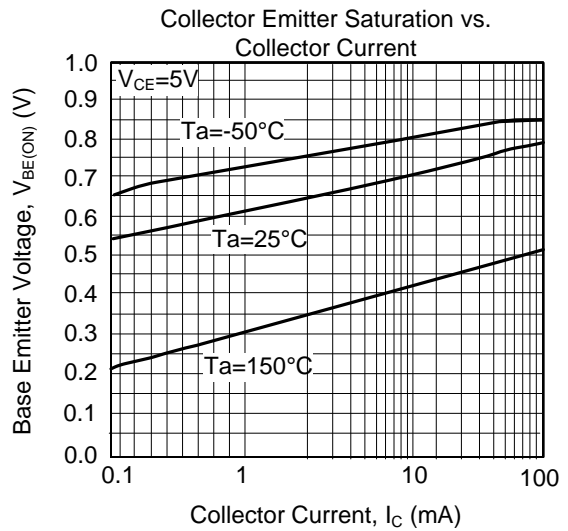
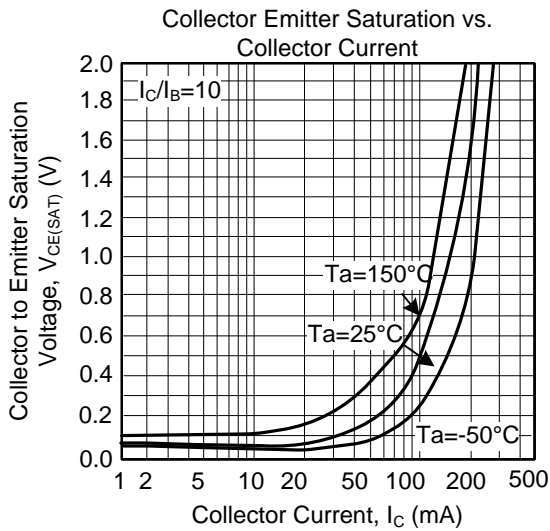
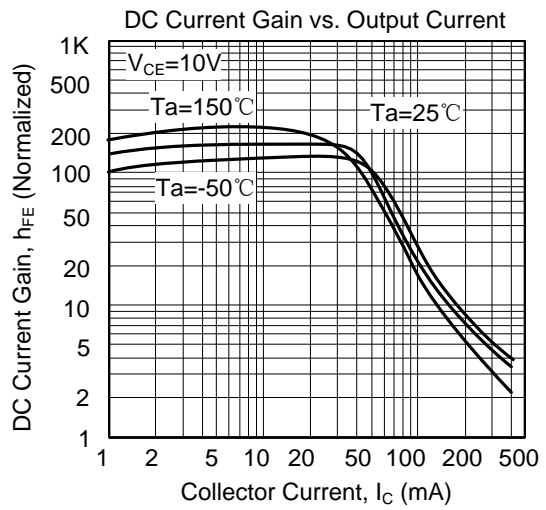
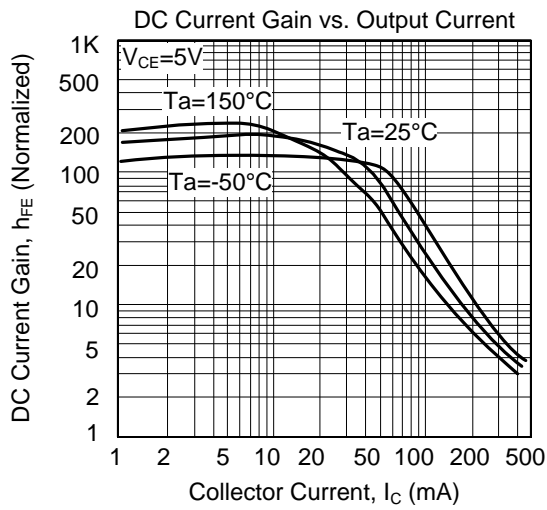

UTC assumes no responsibility for equipment failures that result from using products at values that exceed, even momentarily, rated values (such as maximum ratings, operating condition ranges, or other parameters) listed in products specifications of any and all UTC products described or contained herein. UTC products are not designed for use in life support appliances, devices or systems where malfunction of these products can be reasonably expected to result in personal injury. Reproduction in whole or in part is prohibited without the prior written consent of the copyright owner. The information presented in this document does not form part of any quotation or contract, is believed to be accurate and reliable and may be changed without notice.