

### Features and Benefits

- 1µm CMOS technology
- MLX8 core with 8 accumulators, 80 bytes RAM and 6K ROM
- 1 high voltage input (detection of mains-active)
- Zero-crossing detection input to detect the 50/60Hz
- 7 standard inputs of which 2 can be used as comparator inputs and 2 can be configured as open-collector outputs.
- 15 configurable LCD outputs (segment/backplane)
- 3 relay drivers which can also be used to drive a triac or LED's without the need for external resistors.
- Buzzer driver with programmable frequency
- On-chip 4MHz oscillator, crystal oscillator and low power RC oscillator
- Low power mode (battery or decoupling capacitor)
- High supply voltage eliminates the need for high power resistors
- Battery backup
- On-chip watchdog

### Applications

24 hour timer for cooker applications, coffee maker, ...

### Ordering Information

Part No.	Temperature Suffix	Package	version	Temperature Range
MLX90719	S	LS	-x	0C to 85C

The customer specific version code (defining the ROM content) is indicated with 1 character at the end of the ordering number.

### Functional Diagram

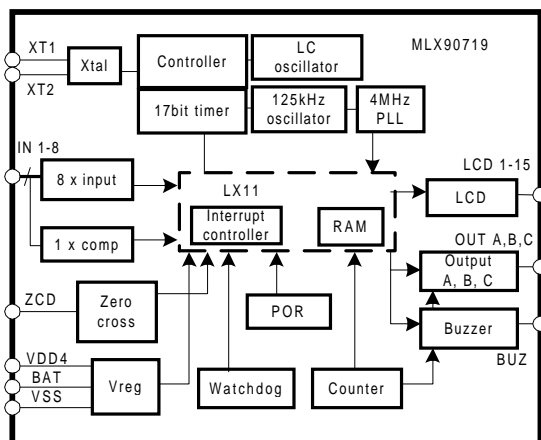

### Description

The ASIC consists of a dedicated microcontroller combined with on-chip analog and digital blocks, which can be configured to a great extend. This makes it ideal to adapt it to different applications by means of an update in the software. The number of external components for the electronic module is minimized. A typical application mainly consists of the MLX90719 ASIC, a number of command buttons, a LCD, a relay, some LED's and a buzzer.

The number of buttons and their function can be freely chosen. The configuration of the LCD, the number of backplanes and its pinout is also under software control. Three outputs are available for a relay and LED's.

### General description

The MLX90719 is an ASIC which is ideally suited for timing control application, low cost as well as high end, such as clocks in coffee machines, cookers, baking equipment,...

The ASIC consists of a dedicated microcontroller combined with on-chip analog and digital blocks, which can be configured to a great extent. This makes it ideal to adapt it to different applications by means of an update in the software. The number of external components for the electronic module is minimized. A typical application mainly consists of the MLX90719 ASIC, a number of command buttons, a LCD, a relay, some LED's and a buzzer. The number of buttons and their function can be freely chosen. The configuration of the LCD, the number of backplanes and its pinout is also under software control. Three outputs are available for a relay and LED's.

### Main functions:

General-purpose timer chip based on the 8-bit LX11 core, including 80 bytes RAM and 6 Kbytes ROM.

Programming of the ROM and selection of all other options is done with one mask.

An interrupt controller guarantees exact timings and a clean refresh rate of the LCD.

High supply voltage eliminates the need for high power resistors.

6 digital inputs and 2 I/O pins (function is under software control).

1 comparator (uses 2 of the digital inputs) which can be used for analog measurements.

3 high current output drivers. They are suitable for driving low cost 12V relays, but other types can also be used. They can also be used to drive triac or LED's without the need for external resistors.

1 buzzer output for piezo electric buzzers, with programmable frequency.

The LCD interface consists of 15 outputs, each of them can be configured as backplane or segment driver.

The time base for the clock function is derived either from the mains frequency or from a crystal oscillator.

The clock frequency for the microcontroller, relay drivers and buzzer output is derived from an on chip oscillator, which is calibrated under software control.

For applications that are disconnected from the mains for longer times, a battery backup can be foreseen, so that the module always keeps track of the time.

For short mains interruptions (up to 5 minutes), the energy in a decoupling capacitor can be used to keep track of the time.

An on-chip watchdog ensures the functioning of the chip under all environmental conditions.

The package size can be adapted to the number of used pins (non-used I/O's do not need to be bonded).

### MLX90719 Electrical Specifications

DC Operating Parameters  $T_A = 0^{\circ}\text{C}$  to  $85^{\circ}\text{C}$ ,  $V_{DD} = 60\text{V}$  (unless otherwise specified)

Parameter	Symbol	Test Conditions	Min	Typ	Max	Units
Ambient temperature	$T_{amb}$		0		85	$^{\circ}\text{C}$
Maximum chip temperature	$T_{ic}$				150	$^{\circ}\text{C}$
Maximum allowed source supply current	$I_{dd4m}$	Drivers off = all the current flows in the chip			6	mA

### Analog features

#### Power supply

The MLX90719 supply pin (VDD4) must be connected by external series resistor and rectifier diode to the mains. An internal Zener function limits the voltage at VDD4 to 70-80V. For proper operation, a decoupling capacitor needs to be connected between VDD4 and VSS (see figure 1).

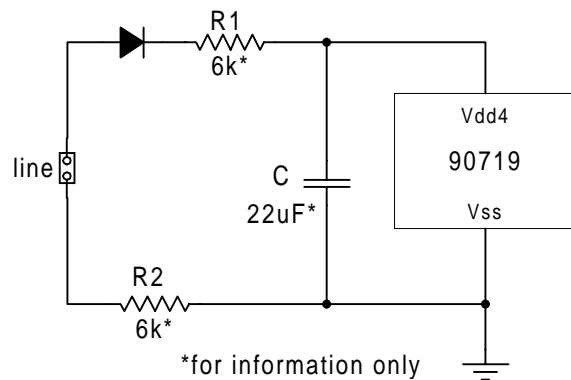

The MLX90719 has several internal supply lines for both analog and digital blocks:

Parameter	Symbol	Test Conditions	Min	Typ	Max	Units
Voltage applied at the supply pin	Vdd4	Idd4 = 5mA DRAINB = Vss	63	73	77	V
Internal buzzer driver supply	Vbuz	Option OBZ3 active		20		V
Internal 11V supply	Vdd2		10	15	12	V
Internal 5V for main oscillator	Vdd1		4.5	5.0	5.5	V
Internal 5V for digital	Vdd	Normal mode	4.0	5.0	6.0	V
		Low power mode	2.7			
LCD driver supply	Vlcd	Option OLCD1 active		3.0		V
		Option OLCD2 active		3.25		V
		Option OLCD3 active		3.5		V
		Option OLCD4 active		3.75		V
		Option OLCD5 active		4		V
		Option OLCD6 active		4.25		V
		Option OLCD7 active		4.5		V
		Option OLCD8 active		4.75		V
		Option OLCD9 active		5		V
		Option OLCD10 active		5.25		V
		Option OLCD11 active		5.5		V
		Option OLCD12 active		5.75		V
		Option OLCD13 active		6		V
		Option OLCD14 active		6.25		V
1Vlcd/3	Vlcd1	Of Vlcd	30	33	36	%
2Vlcd/3	Vlcd2	Of Vlcd	64	67	70	%
	Idd4	For Vdd4 < Vaporl (LPM)			3	uA
		For Vdd4 = 73V		5		mA
Voltage of backup battery	Vbat		2.7	3	3.3	V
Supply for external circuitry	Vext	At Iext = 2mA	3.9	5		V

### Low power mode (LPM)

In low power mode (when the mains have been disconnected from the application) all supply lines are disabled except VDD, which is generated by a low consuming regulator. The current is taken from the external decoupling capacitor of VDD4 or from a backup battery connected to pin BAT. This depends on the type of application defined by the mask option OXBAT implemented within the chip:

OXBAT = 1 for application with battery and crystal.  
 OXBAT = 0 for applications without battery or crystal.

### LCD operating voltage

The LCD operating voltage can have 14 different values and can be chosen by mask options.

### Supply for external components

If the mask option OVEXT is set the MLX90719 can supply some external circuitry from the internal Vdd1 through pin IN5B (which can not be used as input anymore).

### Power On Reset

This module ensures a correct start of the MLX90719 logic.  
 The reset signal (DPORB) rises when  $VDD > V_{dporh}$  and falls when  $VDD < V_{dporl}$

Parameter	Symbol	Test Conditions	Min	Typ	Max	Units
High level threshold	Vdporh				3.4	V
Low level threshold	Vdporl		2.2		2.6	V
Hysteresis	Vdphyst		0.3			V

#### Notes:

The power on reset does not reset the system when entering low power mode with battery ( $V_{dporl} < V_{bat}$ ).  
 The power on reset resets the system if the RAM data may be corrupt due to undervoltage ( $V_{dporl} > RAM$  data retention voltage).

### Analog Power-On Reset

The MLX90719 includes a high voltage power-on reset that watches on VDD3.

This block has two outputs APORL and APORH:

APORL = 1 when  $VDD3 > V_{aporl}$

APORH = 1 when  $VDD3 > V_{aporh}$  (see table 4)

The states of APORH and APORL define the operation mode of the chip (see sections "Sleep manager" and "Interrupt controller").

In low power mode the analog power on reset operates in strobe mode. It is only enabled a few microseconds at each rising edge of the signal ASTR generated by the digital core.

When  $V_{dd3} > V_{aporl}$  the circuit goes out of strobe mode.

Parameter	Symbol	Test Conditions	Min	Typ	Max	Units
High level threshold	Vaporh			65		V
Low level threshold	Vaporl			50		V
Hysteresis	Vaphyst		10			V
Strobe frequency	Fastr	Slow rate of $V_{dd3} > 200V/s$	25			Hz

### Zero crossing detector

The MLX90719 includes a zero crossing detector on pin ZCD. This detector contains two comparators with hysteresis. The first comparator has negative thresholds and the second one has positive thresholds (see table 5). Outputs ZOUT1 and ZOUT2 of those comparators are changing as follows:

ZOUT1 rises when  $V_{mains} > V_{z1h}$   
 ZOUT1 falls when  $V_{mains} < V_{z1l}$   
 ZOUT2 rises when  $V_{mains} > V_{z2h}$   
 ZOUT2 falls when  $V_{mains} < V_{z2l}$

A mask option defines the levels of those thresholds. Low levels (+/- 5V, option OZCD = 0) are suitable for zero crossing detection and high levels (+/- 20V, option OZCD = 1) for frequency detection with a better noise immunity.

A 1M $\Omega$  resistor must be connected between pin ZCD and the mains.

Parameter	Symbol	Test Conditions	Min	Typ	Max	Units
High level threshold 1	Vz1h	Rzcd = 1Mohm		-5		V
		Rzcd = 1Mohm, OZCD = 1		-5		V
Low level threshold 1	Vz1l	Rzcd = 1Mohm		-9		V
		Rzcd = 1Mohm, OZCD = 1		-29		V
High level threshold 2	Vz2h	Rzcd = 1Mohm		9		V
		Rzcd = 1Mohm, OZCD = 1		29		V
Low level threshold 2	Vz2l	Rzcd = 1Mohm		5		V
		Rzcd = 1Mohm, OZCD = 1		5		V
External resistor	Rzcd	Vline = 230VAC typical	0.8	1	1.2	Mohm

### Low voltage inputs

The MLX90719 has 7 CMOS Schmitt trigger inputs with internal pull-up.

**Note:** the input signals are inverted in the digital core so these inputs are active low.

Signal ENINB (active at 0) enables the pull-up current flowing through external pad to VSS if the input is pushed to VSS. When ENINB=1 (input disabled), DINxB = 1.

The programmer must enable inputs by setting bit ENIN of P7 at least 5 $\mu$ s before reading the input port P3 (see section "I/O ports"). The debouncing of inputs must be done by software.

Parameter	Symbol	Test Conditions	Min	Typ	Max	Units
Pull-up current	Ipu1	Input to Vss	40	70	100	$\mu$ A
Low level threshold	Vthinl		30			%Vdd
High level threshold	Vthin				70	%Vdd
Hysteresis	Vhystin		5			%Vdd

#### Multipurpose inputs:

Inputs 3 and 6 can be used also as pull-down outputs: the pull down transistors are turned on by setting bits PD3 and PD6 of P6 (see section "I/O ports").

Inputs 1, 2 and 4 are used by the on-chip comparator (see section "comparator")

Input 5 can be turned into supply for external circuitry by mask option OVEXT (see "Power supply").

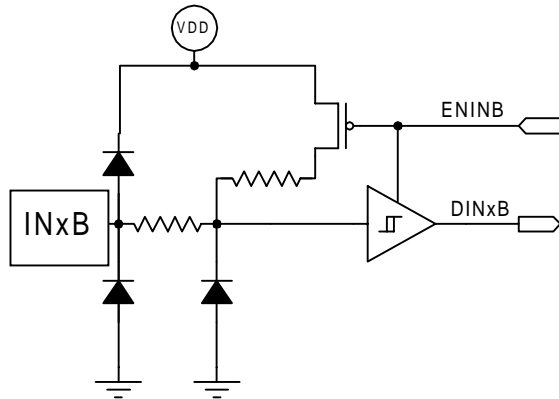

### High voltage input

The MLX90719 has an eighth input that can be used either as a standard input (as described above) or as an high voltage input to detect the mains via an external resistor. The high voltage mode is enabled if mask option OIN7 is set.

Output DIN7B of this detector is high when  $V_{mains} > V_{thinh2}$  and low when  $V_{mains} < V_{thinl2}$ .

**Note:** signal DIN7B is inverted within the digital core.

Parameter	Symbol	Test Conditions	Min	Typ	Max	Units
Pull-down current	Ipd2			12		uA
Low level threshold	Vthinl2	Rin = 1Mohm		6.9		V
High level threshold	Vthinh2	Rin = 1Mohm		12.3		V
External resistor	Rin		0.8	1	1.2	Mohm

### Main oscillator

The MLX90719 contains a 4Mhz on-chip oscillator. In low power mode this oscillator is turned off.

Parameter	Symbol	Test Conditions	Min	Typ	Max	Units
Master frequency of the main oscillator (signal CKM)	Fckm	Over full temp. and supply range	2.4	4.0	5.6	MHz

### Low power crystal oscillator

In case of applications with battery and crystal (OXBAT = 1) the MLX90719 uses a low power crystal oscillator as time reference for both normal and low power mode.

This oscillator requires a standard 32kHz crystal connected between pin XTAL1 and pin XTAL2.

No external capacitor is required for proper operation.

Parameter	Symbol	Test Conditions	Min	Typ	Max	Units
Master frequency of the crystal oscillator	Fckx	Over full temp. and supply range		32768		Hz

**Note:** This oscillator is disabled if OXBAT = 0.

### Low power RC oscillator

In case of applications without battery or crystal (OXBAT = 0) the MLX90719 uses an on-chip low power RC oscillator to count time during a few minutes after the mains has been disconnected (low power mode).

Parameter	Symbol	Test Conditions	Min	Typ	Max	Units
Master frequency of the low power RC oscillator	Fckl	Over full temp. and supply range	1.0	2.5	5	kHz

**Notes:**

As the CPU must calibrate it in normal mode, the low power oscillator is running continuously. The low power RC oscillator is disabled if OXBAT = 1.

### LCD outputs

The MLX90719 has 15 configurable LCD outputs able to drive either a backplane or a segment by mask option:  
 OLCDDx = 0 => segment  
 OLCDDx = 1 => backplane

The LCD voltages are defined according to bits LCDx and CKLCD written in P3 and P4 (see section "I/O ports"). With Vcd1 and Vcd2 being respectively 1/3Vlcd and 2/3Vlcd, the MLX90719 is suitable for LCD having 1, 2, 3 or 4 backplanes.

Parameter	Symbol	Test Conditions	Min	Typ	Max	Units
Output impedance	Rolcd	All cases			20	kohm

OLCDDx	LCDx	CKLCD	OUT
0	0	0	Vlcd1
0	0	1	Vlcd2
0	1	0	Vlcd
0	1	1	Vss
1	0	0	Vlcd2
1	0	1	Vlcd1
1	1	0	Vss
1	1	1	Vlcd

### Relay drivers

The MLX90719 includes 3 pull-down power outputs A, B, and C able to drive relays, triacs or LED's. The gates of the drivers are controlled respectively by signals POUTA, POUTB and POUTC generated by the digital core (see section "PWM generator"). Each driver has its source and its drain connected to a pad (DRAINx and SOURCEx) except driver C of which the source is connected to the ground. This allows a series connection of the drivers. In such a configuration the current flowing through the relay is used to feed the LED's.

### Internal current generator

In applications based on the following schematic, where the LED('s) may have to be driven when the relay is off, an internal current peak generator can be activated to supply the LED's through pin SourceA. This function is enabled by bit INTCUR of P5 (see section "I/O ports"). When INTCUR is set the current generator is activated like a relay by signal PINT at frequency Fpwm and at 14.3% duty cycle (see "PWM generator").

**Note:** If the application has no relay, this feature allows the MLX90719 to drive 2 LED's without any external resistors.



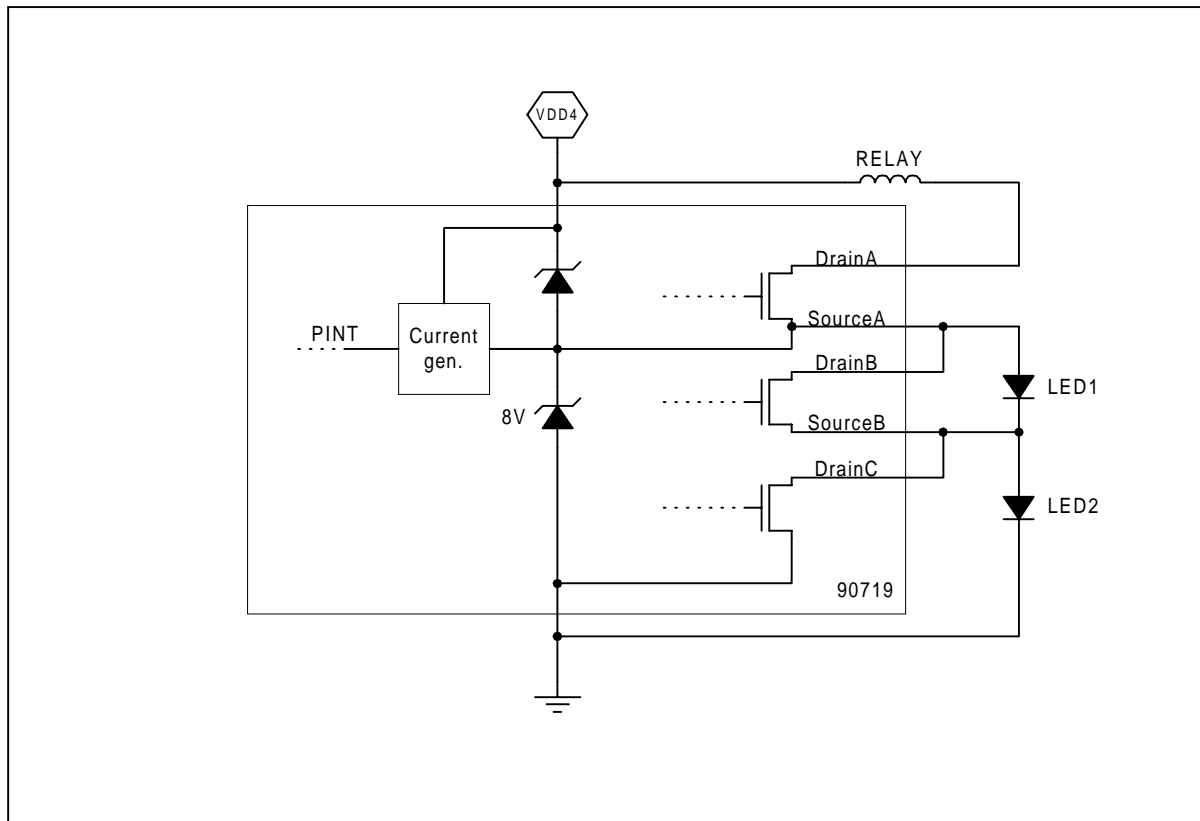

Parameter	Symbol	Test Conditions	Min	Typ	Max	Units
Ron of driver A	RonA	Source A pushed to VSS		10	30	W
Ron of driver B	RonB	Source B pushed to VSS		10	30	W
Ron of driver C	RonC			10	30	W
Voltage on pin DrainA	Vda				85	V
Voltage on pin DrainB	Vdb				85	V
Voltage on pin DrainC	Vdc				85	V
Voltage on pin SourceA	Vsa				8	V
Voltage on pin SourceB	Vsb				4	V
Rising edge duration, all drivers	Tr	Load = 5k from VDD4 = 70V		1		us
Falling edge duration, all drivers	Tf	Load = 5k from VDD4 = 70V		1		us

### Buzzer driver

The MLX90719 includes a piezo buzzer driver.

The push-pull output stage of this driver operates at 15V. An internal resistor between the output pin and the push-pull stage protects the chip against reverse piezo effect.

Parameter	Symbol	Test Conditions	Min	Typ	Max	Units
Output impedance	Rob		100	300	600	ohm
Maximum output frequency	Fbuzm				8	kHz

### Comparator

The MLX90719 includes a multi-purpose comparator.

Setting bit ECOMP of P3 (see section "I/O ports") enables this comparator. Inputs IN1B and IN2B become respectively the positive and negative inputs of the comparator and IN4B becomes its output via a tri-state buffer.

To reduce the number of external components in applications using the comparator, a resistive bridge and a feed back resistor (both internal) can be connected on the positive input of the comparator by mask option OCOMP.

#### Notes:

Some logic in the digital core ensures that ENIN12B and ENIN4B = 1 when ECOMP = 1.

When ECOMP = 0 the comparator output is fixed to "1".

A programmable prescaler has been implemented to allow frequency measurement at the output of the comparator (line IN4B). The status of bits CM0 and CM1 of P3 define the prescale ratio as described in table 15:

electrical characteristics of the comparator.

Parameter	Symbol	Test Conditions	Min	Typ	Max	Units
Common mode range	Vcm		20		80	%Vdd
Offset	Vcoff		-30		30	mV

#### CM1 CM0 Divide ratio

0	0	Prescaler bypassed
0	1	/16
1	0	/32
1	1	/64

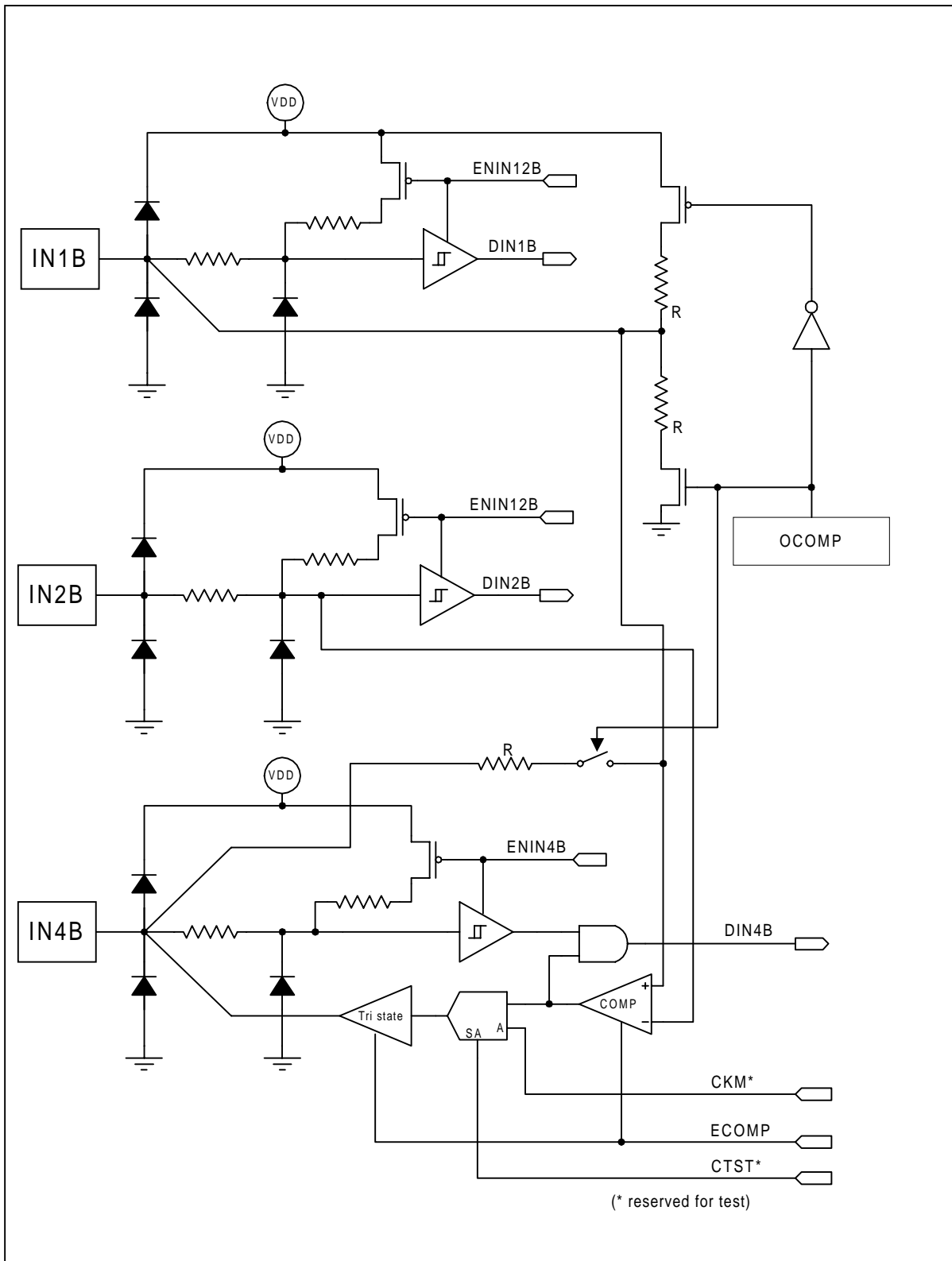

### Digital features

#### I/O ports

The MLX90719 has 9 port addresses. Read and write instructions to the same address do not access to the same port:

Out	Description	Msb								LSb
P0	Timer compare low	TCP7	TCP6	TCP5	TCP4	TCP3	TCP2	TCP1	TCP0	
P1	Timer compare high	TCP15	TCP14	TCP13	TCP12	TCP11	TCP10	TCP9	TCP8	
P2	Timer ctrl, comparator	CM1	CM0	ECOMP	TRST	COUNT	EN24H	MUX1	MUX0	
P3	LCD port	LCD8	LCD9	LCD10	LCD11	LCD12	LCD13	LCD14	LCD15	
P4	LCD port	CKLCDB	LCD1	LCD2	LCD3	LCD4	LCD5	LCD6	LCD7	
P5	Power outputs	Not used	INTCUR	PC1	PC0	PB1	PB0	PA1	PA0	
P6	PWM frequency adjust	PD6	PD3	DIV5	DIV4	DIV3	DIV2	DIV1	DIV0	
P7	IT control, sleep, wdog	PWD	RSTWD	FLAG	ENIN	RFHIT	ETIMI	ECLKI	ESUPI	
P8	Sound, test	CTST*	DTST*	MTST*	LTST*	SOUND3	SOUND2	SOUND1	SOUND0	

Note: \* = reserved for test.

in	Description	Msb								LSb
P0	Timer low	T7	T6	T5	T4	T3	T2	T1	T0	
P1	Timer high	T15	T14	T13	T12	T11	T10	T9	T8	
P2	Timer msb, test	BATB*	X*	X*	X*	X*	X*	X*	T16	
P3	Chip inputs	IN7	IN6	IN5	IN4	IN3	IN2	IN1	IN0	
P4	Not used	X								
P5	Not used	X								
P6	Not used	X								
P7	IT handler, flag	ZCD	0	FLAG	0	0	PTIMI	PCLKI	PSUPI	
P8	Not used	X								

Note: \* = reserved for test.

### Sleep manager and watch dog

At power-on-reset the MLX90719 is in low power mode (PWD = 1).  
 When VDD3 reaches 65V (APORH = 1) PWD is reset and the main oscillator starts. To ensure a correct start of the analog blocks, the CPU is kept in reset status for 2<sup>15</sup> main clock pulses (typically 8.2ms).  
 Once the microcontroller is working a watchdog circuitry will generate a system reset if the user program fails to reset the watchdog counter. The watchdog delay is given by:

$$T_{wd} = 57344 \times 1/F_{ckm} (= 14ms \text{ if } F_{ckm} = 4MHz)$$

The watchdog counter is reset each time a 1 is written on bit RSTWD of P7.

To distinguish a wake-up after power-on reset and a wake-up after low power mode, one can read the status of bit FLAG (read/write bit in P7). This will be 0 after power on reset and 1 after low power mode if FLAG has been set during normal mode.

The low power mode is set by bit PWD of P7. Since the main oscillator stops as soon as PWD = 1, setting bit PWD must be the last instruction of the supply interrupt subroutine (see interrupt controller).

### Debouncing

A debounce circuit eliminates positive spikes on line APORH to avoid unexpected wake-up due to disturbances. The debounce time (tdaporh) depends on OXBAT.

If OXBAT = 1 it derives from the crystal oscillator frequency and:

$$7.8ms < tdaporh < 11.7ms$$

If OXBAT = 0 it derives from the low power RC oscillator frequency and:

$$3.2ms < tdaporl < 24ms$$

### Timer

The MLX90719 includes a 17-bit timer preceded by a 15-bit prescaler. The clock of the timer can be taken from four different sources defined by the bits MUX0 and MUX1 of P2:

MUX1	MUX0	Timer clock source	Description
0	0	CK125K	Main clock divided by 32 (typically 125kHz)
0	1	D2P15	/2 <sup>15</sup> prescale output
1	0	D2P9	/2 <sup>9</sup> prescale output
1	1	D2P3	/2 <sup>3</sup> prescale output

The battery and crystal option (OXBAT) defines which clock is connected to the prescaler input:

If OXBAT = 1: the crystal oscillator output (CKX) drives the prescaler input

If OXBAT = 0: the low power RC oscillator output (CKL) drives the prescaler input.

Control bits (P2):

EN24H = 1 enables the 24h mode (see below).

COUNT = 1 enables the counter

TRST = 1 resets the counter and the prescaler.

### Normal operation

In normal mode the timer is used as a free-running counter on CK125K. It can be read at any time without stop. An interrupt is generated when the value of the timer reaches the value of the timer compare written in P1-P0.

### Low power mode if crystal oscillator (OXBAT = 1)

In this mode the clock of the timer must be connected to the /2<sup>15</sup> output of the prescaler (1Hz).

Setting the 24h mode turns the timer into a modulo 86400 counter if a correct value has been written in P1-P0. The timer being automatically reset when T16=1 and T[15:0] = TCP[15:0], this value must be 517Fh to give T

[16:0] = 86399.

At wake-up the value of the timer is the number of seconds passed since the beginning of sleep. An arbitrary time of 0.5s should be added to this number to compensate the error of 0/- 1s due to the timer resolution.

**Low power mode without crystal oscillator (OXBAT = 0)**

In this mode the timer clock must be connected to the /2<sup>9</sup> output of the prescaler (about 5Hz).

At wake up a calibration of the low power oscillator can be done by connecting the timer clock to the /2<sup>3</sup> output of the prescaler and counting during 250ms (given by 25 half period of the mains at 50Hz and 30 half period at 60Hz).

Those prescale ratios allow a calibration of the low power oscillator with only one 16-bit division if its frequency is in the range of 1-5kHz and if the maximum time to count is 5min.

**Interrupt controller**

The MLX8 core accepts only one interrupt source.

The MLX90719 has 3 interrupt sources:

- Supply
- Clock reference (crystal oscillator or zero crossing detector)
- Timer

These three hardware parts will interrupt the MLX8 core to address 21h (interrupt address).

In order to recognize the interrupting device, an interrupt handler is readable at port P7 (bits PSUPI, PCLKI and PTIMI). In case of interrupt:

PSUPI is set if the voltage on VDD3 has decreased under 50V (APORL=0)

PCLKI is set if a clock reference pulse has occurred.

PTIMI is set if the timer has reached the timer compare value (16-bit word in P0-P1).

Option OXBAT defines which source generates the clock reference interrupt:

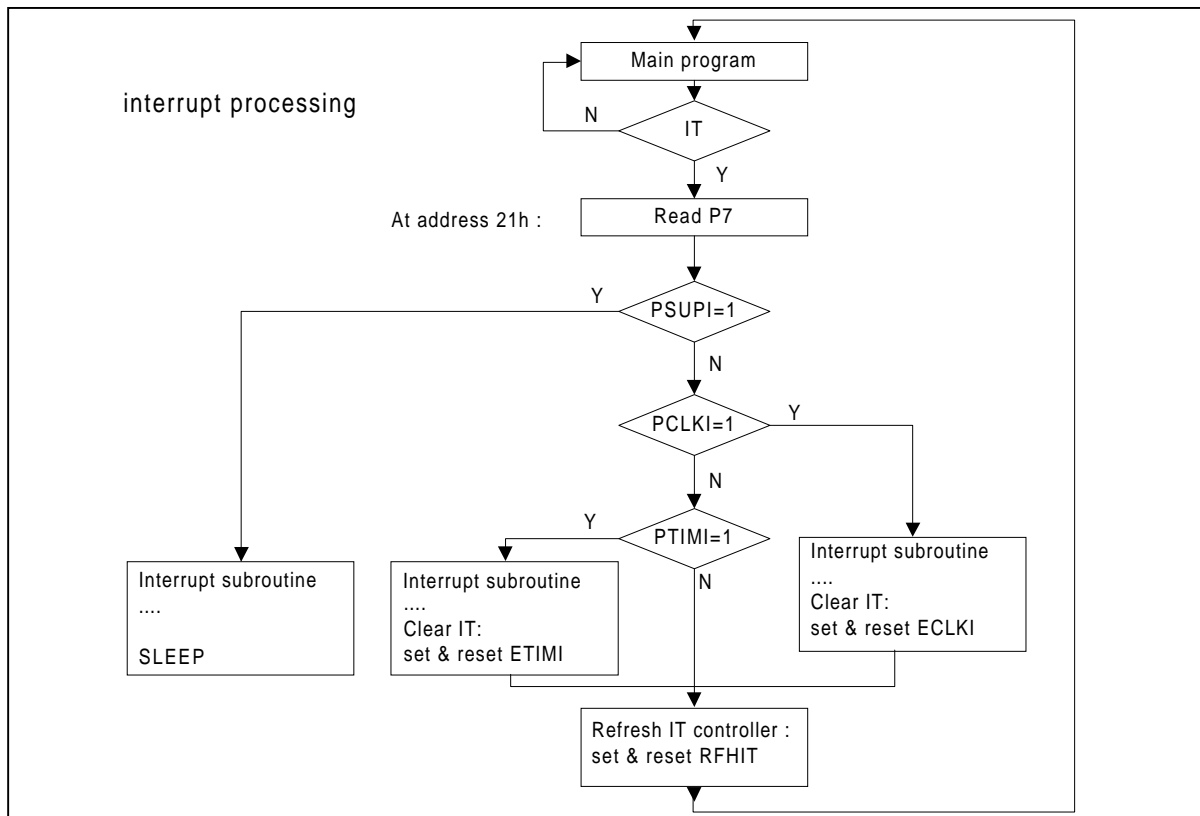

If OXBAT = 1 the clock interrupts are generated at the rate of 128Hz (Crystal frequency divided by 256).  
 If OXBAT = 0 the clock interrupts are generated at the rate of twice the mains frequency by the zero crossing detector (combination of signals ZOUT1 and ZOUT2) that is 100Hz or 120Hz.

The main purpose of the timer interrupt is to rate the multiplexing of the LCD but it can be used to control a triac.

Each interrupt can be enabled/disabled and cleared by setting or resetting ESUPI, ECLKI and ETIMI in P7. As several interrupts may occur at the same time a fourth control bit RFHIT (of P7) has been implemented to refresh the interrupt controller after each interrupt subroutine. The flow chart shows the interrupt process:

### Debouncing

A debounce circuit eliminates negative spikes on line APORL to avoid unexpected supply interrupts due to disturbances. The debounce time (tdaporl) depends on OXBAT.

If OXBAT = 1 it derives from the crystal oscillator frequency and:

$$7.8\text{ms} < \text{tdaporl} < 11.7\text{ms}$$

If OXBAT = 0 it derives from the low power RC oscillator frequency and:

$$3.2\text{ms} < \text{tdaporl} < 24\text{ms}$$

Both outputs of the zero crossing detector are combined in a debounce circuit that generates a periodic signal rising at each zero crossing of the mains without delay. This signal (ZCD) is connected to the interrupt handler (if OXBAT = 0) at bit PCLKI. The debounce period is typically 2ms but can vary from 0.6ms to 6ms because it is generated from the low power RC oscillator.

### Zero crossing signal on P7

The zero crossing signal is readable at bit ZCD of P7. This feature may be used to detect zero crossing in crystal-based applications.

### PWM generator

The three relay drivers of the MLX90719 can be driven independently at 0%, 14.3%, 28.6% and 100% duty cycle (except driver A which can not be driven at 100% duty).

Bits PA0 to PC1 of P5 set the duty cycle of each driver (signals POUTA, POUTB and POUTC) and bit INTCUR activates the current peak generator (signal PINT):

INTCUR	Px1	Px0	Duty cycle of POUTx	Duty cycle of PINT
X	0	0	0 %	
X	0	1	14.3 %	
X	1	0	100 % *	
X	1	1	28.6 % for t30 then 14.3%	
0	X	X		0 %
1	X	X		14.3%

Note: \* = 0% for driver A

t30 is given by:  $t_{clki} < t_{30} < 2t_{clki}$

where tclki is the delay between two clock interrupts:

$$t_{clki} = 10\text{ms} \text{ if zero crossing detector is used and } F_{\text{mains}} = 50\text{Hz}$$

$$t_{clki} = 8.33\text{ms} \text{ if zero crossing detector is used and } F_{\text{mains}} = 60\text{Hz}$$

$$t_{clki} = 7.81\text{ms} \text{ if crystal oscillator is used}$$

In all cases:  $7.81\text{ms} < t_{30} < 15\text{ms}$

The PWM frequency is programmable. It depends on the main oscillator frequency and on the 6-bit divide ratio written in P6:

$F_{pwm} = F_{ckm} / (7 \times DIV[6:0])$  (= 22kHz for  $F_{ckm} = 4\text{MHz}$  and  $DIV[6:0] = 26$ )

As  $F_{ckm}$  can vary, the divide ratio must be calculated periodically by software to reference  $F_{pwm}$  to the crystal frequency or to the mains frequency.

### Sound generator

The MLX90719 includes a sound generator able to produce more than 8 tonalities.

The output frequency  $F_{buz}$  is defined by bits SOUND3 to SOUND0 of P3:

$F_{buz} = (7 \times F_{pwm}) / (8 \times S)$  (see table 21)

SOUND3	SOUND2	SOUND1	SOUND0	S	Fbuz if Fpwm = 22kHz
0	0	0	0	-	Off
0	0	0	1	2	(9.62kHz)
0	0	1	0	3	6.42kHz
0	0	1	1	4	4.81kHz
0	1	0	0	5	3.85kHz
0	1	0	1	6	3.21kHz
0	1	1	0	7	2.75kHz
0	1	1	1	8	2.41kHz
1	0	0	0	9	2.14kHz
1	0	0	1	10	1.93kHz
1	0	1	0	11	(1.75kHz)
1	0	1	1	12	(1.60kHz)
1	1	0	0	13	(1.48kHz)
1	1	0	1	14	(1.38kHz)
1	1	1	0	15	(1.28kHz)
1	1	1	1	16	(1.20kHz)

### Mask options

The following table lists all options of the MLX90719 chip:



Name	Value = 0	Value = 1	Bit*
OXBAT	No battery, no crystal	Battery + crystal	0
OVLCD1		Vlcd = 3V	1
OVLCD2		Vlcd = 3.25V	2
OVLCD3		Vlcd = 3.5V	3
OVLCD4		Vlcd = 3.75V	4
OVLCD5		Vlcd = 4V	5
OVLCD6		Vlcd = 4.25V	6
OVLCD7		Vlcd = 4.5V	7
OVLCD8		Vlcd = 4.75V	8
OVLCD9		Vlcd = 5V	9
OVLCD10		Vlcd = 5.25V	10
OVLCD11		Vlcd = 5.5V	11
OVLCD12		Vlcd = 5.75V	12
OVLCD13		Vlcd = 6V	13
OVLCD14		Vlcd = 6.25V	14
OVEXT	No external 5V supply	External 5V supply on IN5B	15
OZCD	Low thresholds	High thresholds	16
OIN7	Low voltage	High voltage	17
OCOMP	Bridge + feedback disabled	Bridge + feedback enabled	18
OLCD1	LCD1 = segment	LCD1 = backplane	19
OLCD2	LCD2 = segment	LCD2 = backplane	20
OLCD3	LCD3 = segment	LCD3 = backplane	21
OLCD4	LCD4 = segment	LCD4 = backplane	22
OLCD5	LCD5 = segment	LCD5 = backplane	23
OLCD6	LCD6 = segment	LCD6 = backplane	24
OLCD7	LCD7 = segment	LCD7 = backplane	25
OLCD8	LCD8 = segment	LCD8 = backplane	26
OLCD9	LCD9 = segment	LCD9 = backplane	27
OLCD10	LCD10 = segment	LCD10 = backplane	28
OLCD11	LCD11 = segment	LCD11 = backplane	29
OLCD12	LCD12 = segment	LCD12 = backplane	30
OLCD13	LCD13 = segment	LCD13 = backplane	31
OLCD14	LCD14 = segment	LCD14 = backplane	32
OLCD15	LCD15 = segment	LCD15 = backplane	33

\* Only applicable for the development version of the MLX90719

## Pinout

Package type: SSOP36

Name	Num. (CCW)	Description	Options
LCD15	18		
LCD14	19		
LCD13	20		
LCD12	21		
LCD11	22		
LCD10	23		
LCD9	24		
LCD8	25		
LCD7	26		
LCD6	27		
LCD5	28		
LCD4	29		
LCD3	30		
LCD2	31		
LCD1	32		
XTAL1	33		
XTAL2	34		
BAT	35	Battery pin	
IN0B	36	Input 0	
IN1B	1	Input 1	Comparator "+"
IN2B	2	Input 2	Comparator "-"
IN3B	3	Input 3	
BUZ	4	Buzzer output	
VSS	5	Vss	
DRAIN C	6	Drain of driver C	
SOURCE B	7	Source of driver B	
DRAIN B	8	Drain of driver B	

Name	Num. (CCW)	Description	Options
SOURCEA	9	Source of driver A	
DRAINA	10	Drain of driver A	
VDD4	11	Supply pin	
IN4B	12	Input 4	Comparator output
IN5B	13	Input 5	Vext
IN6B	14	Input 6	
IN7B	15	Input 7 (with high voltage capability)	
ZCD	16	Main frequency detector input	

## **Development board**

Melexis has available a development kit which contains a evaluation circuit board, a ROM emulator, interface cables, all necessary software and a sample of the MLX90917 (development version). The evaluation board is a standard version that can be customized to an extended range of applications. The standard version includes a buzzer, a LCD, a relay and some breadboard space to build up the customized application. (push buttons, high-power outputs, temperature measurement, ...) The available software consists of assembler, linker, simulator and the interface software for the ROM emulator. By using this emulator the user is able to see and modify all internal registers and the RAM contents. On a break event, the user program is replaced by a shadow monitor, which exchanges data with the host.

For software development a special version of the MLX90917 is available. This version differs from the standard MLX90917 in two ways. It has a second ring of pads around the normal chip. In this way the chip can be used with external memory, which makes it also possible to use the ROM emulator. With the development version it is also possible to program the different 'mask' options. The state of the different options should be written by the programmer in specific ROM bytes. During the initialization phase of the chip, a dedicated part in the software reads this bytes and writes the contents in specific memory elements, defining in this way the chosen options.

More information about the development board and software can be found in the specific documentation describing the MLX90719 Development Kit.

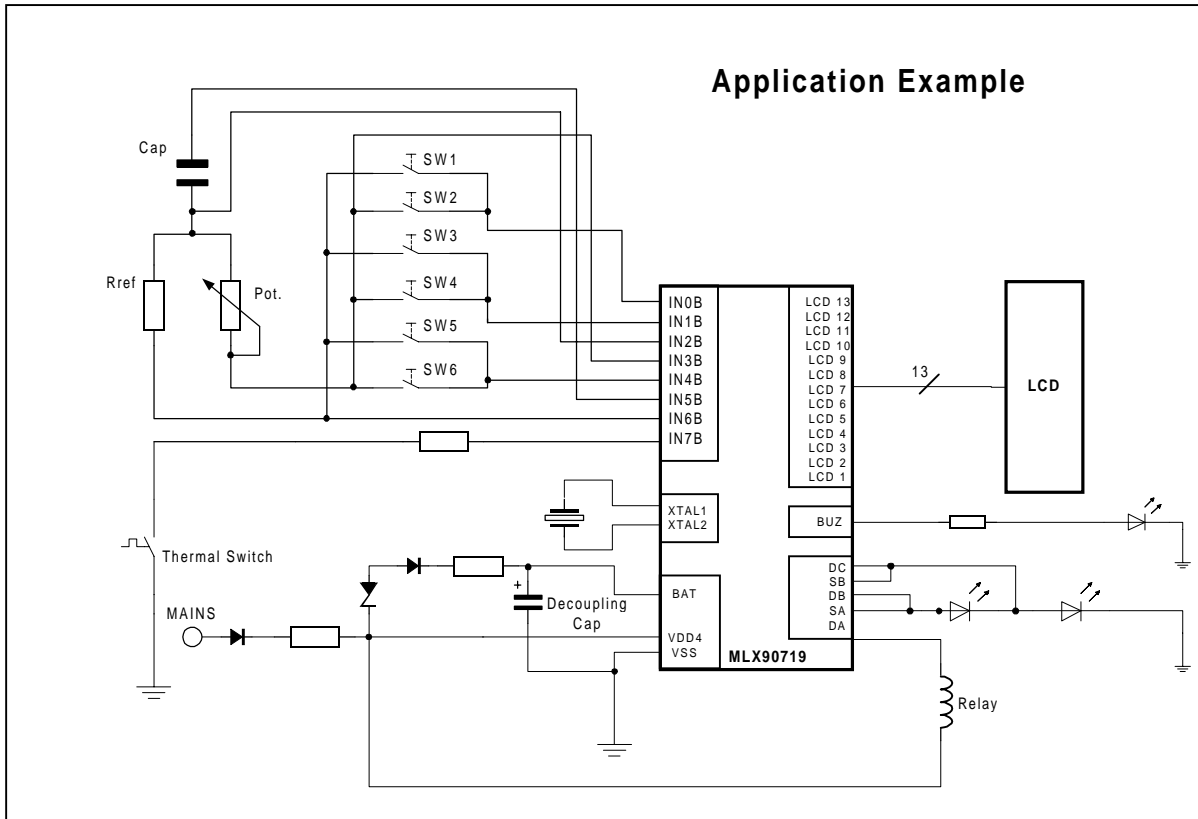

## Related documents

**MLX90719 application note:** a clock timer based on the MLX90719.

**LX11 simulator documentation:**  
[http://www.melexis.com/site/know-how/mcu/tools/mcu\\_tools\\_softsimul.htm](http://www.melexis.com/site/know-how/mcu/tools/mcu_tools_softsimul.htm).

**MLX90719 development kit documentation:** describes how to define an application with the MLX90719.

## ESD Precautions

Electronic semiconductor products are sensitive to Electro Static Discharge (ESD). Always observe Electro Static Discharge control procedures whenever handling semiconductor products.

## Disclaimer

Melexis reserves the right to periodically make modifications to product specifications. The information included herein is believed to be accurate and reliable. However, Melexis assumes no responsibility for its use; nor for any infringements of patents or other rights of third parties which may result from its use.

**MLX00000 Physical Characteristics**

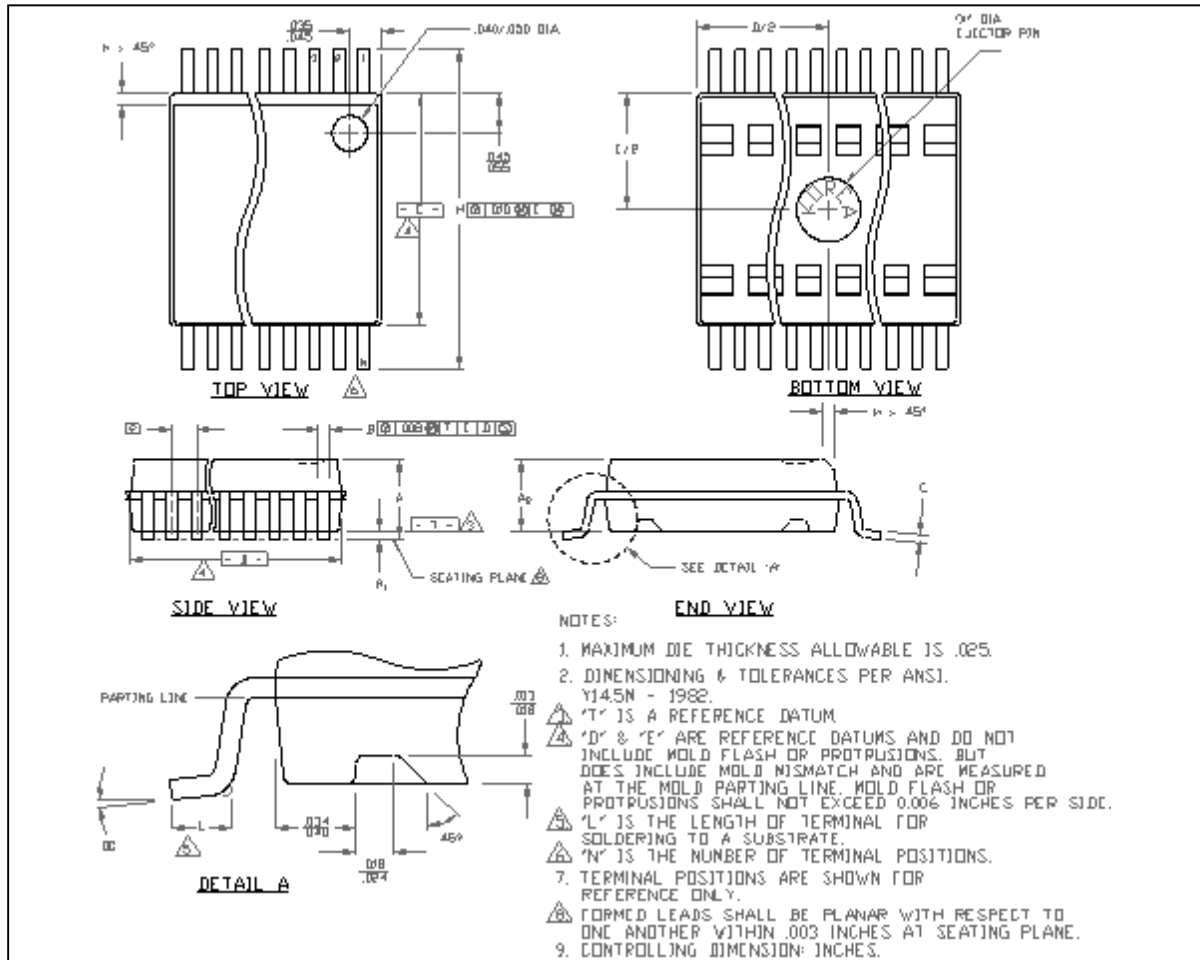

For the latest version of this document,  
Go to our website at:  
[www.melexis.com](http://www.melexis.com)  
Or for additional information  
contact Melexis Direct:

**USA**  
Melexis Inc.  
41 Locke Road, Concord, NH 03301  
Phone: +1 603 223 2362 Fax: +1 603 223 9614  
E-mail: [sales\\_usa@melexis.com](mailto:sales_usa@melexis.com)

**United Kingdom**  
Silicon Concepts  
PCB Lynchborough Road, Hampshire GU30 7SB, United Kingdom  
Phone: +44 1428 751 617 Fax: +44 1428 751 603  
E-mail: [sales\\_uk@melexis.com](mailto:sales_uk@melexis.com)

**Germany**  
Am Seestern 8, 40547 Düsseldorf, Germany  
Phone: +49 211 5360212 Fax: +49 211 5360250  
E-mail: [sales\\_de@melexis.com](mailto:sales_de@melexis.com)

**France**  
Melexis France  
Tour Arago, 5 rue Bellini, 92806 Puteaux-La-Défense, France.  
Phone: +33 1 47 78 11 34 Fax: +33 1 47 78 06 35  
E-mail: [sales\\_france@melexis.com](mailto:sales_france@melexis.com)

**Italy**  
Dimacred IRL  
Via Papa Giovanni XXIII no. 25, 20046 Biassono, Italy  
Phone: +39 039 249 4856 Fax: +39 039 491773  
E-mail: [sales\\_italy@melexis.com](mailto:sales_italy@melexis.com)

**Japan**  
Satori Electric Co., LTD  
1-14-10 Shiba, Minato-Ku, Tokyo, Japan  
Phone: +81 3 3452 7171 Fax: +81 3 3769 2197  
E-mail: [sales\\_japan@melexis.com](mailto:sales_japan@melexis.com)

**Taiwan**  
Beechwood Int'l Taiwan Co.  
Room 8, 17F, No. 189, Taipei, Taiwan  
Phone: +886 2 2739 3322 Fax: +886 2 2739 3090  
E-mail: [sales\\_taiwan@melexis.com](mailto:sales_taiwan@melexis.com)

