

MC34216A

Advance Information

Programmable Telephone Line Interface Circuit with Loudspeaker Amplifier

The MC34216A is developed for use in telephone applications where, besides the standard telephone functions, the group listening-in feature is also required. In cooperation with a microcontroller, the circuit performs all basic telephone functions including DTMF generation and pulse-dialing. The listening-in part includes a loudspeaker amplifier, an anti-howling circuit and a strong supply. In combination with the TCA3385, the ringing is performed via the loudspeaker.

- Programmable DC Mask, for France, U.K., and Voltage Regulated Countries
- DC Mask for France and U.K. (MC34216ADWF)
- Programmable Volume for Listening-In and Ringing
- Small Amount of External Components
- On-Chip DTMF and Ring Signal Generator
- Efficient Supply Point for Loudspeaker Amplifier and Peripherals
- Programmable Modes for Speakerphone, Answering Machine, Fax and Modem Applications
- Pilot and Idle Tones Provide Extra Phone Features

PROGRAMMABLE TELEPHONE LINE INTERFACE CIRCUIT WITH LOUDSPEAKER AMPLIFIER

SEMICONDUCTOR
TECHNICAL DATA

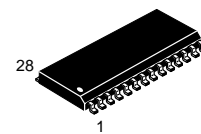

DW, DWF SUFFIX
PLASTIC PACKAGE
CASE 751F

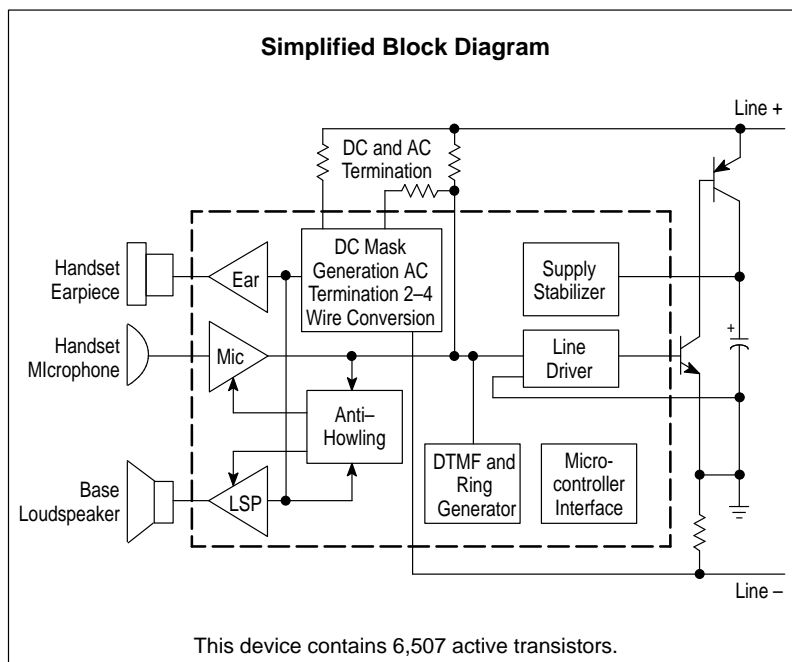

PIN CONNECTIONS

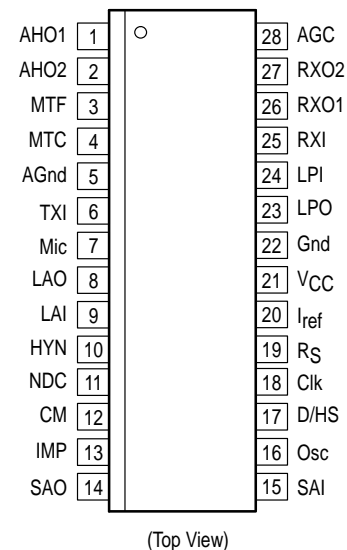

ORDERING INFORMATION

Device	Operating Temperature Range	Package
MC34216ADW	$T_A = 0^\circ \text{ to } +70^\circ \text{C}$	SO-28L
MC34216ADWF		SO-28L

FEATURES

Line Driver and Supply

- DC and AC Termination of the Line
- Programmable DC Mask: France, U.K., Startup, Low Voltage (MC34216ADW)
- Programmable DC Mask: France, U.K., Startup (MC34216ADWF)
- Current Protection
- Adjustable Set Impedance for Resistive and Complex Termination
- Efficient Supply Point for Loudspeaker Amplifier and Peripherals

Handset Operation

- Transmit and Receive Amplifiers
- Adjustable Sidetone Network
- Line Length AGC
- Microphone and Earpiece Mute
- Earpiece Gain Increase Switch
- Microphone Squelch Function
- Transmit Amplifier Soft Clipping

Dialing and Ringing

- Generates DTMF, Pilot Tones and Ring Signal
- Interrupter Driver for Pulse-Dialing
- Low Current While Pulse-Dialing
- Optimized for Ringing via Loudspeaker
- Programmable Ring Melodies
- Uses Inexpensive 500 kHz Resonator

Loudspeaking Facility

- Integrated Loudspeaker Amplifier
- Peak-to-Peak Limiter Prevents Distortion
- Programmable Volume
- Anti-Howling Circuitry for Group Listening-In
- Interfacing for Handsfree Conversation

Application Areas

- Corded Telephony with Group Listening-In
- Cordless Telephony Base Station with Group Listening-In
- Telephones with Answering Machines
- Fax, Intercom, Modem

MAXIMUM RATINGS

Rating	Symbol	Min	Max	Unit
Maximum Junction Temperature	T_J	–	+150	°C
Storage Temperature Range	T_{stg}	–65	+150	°C

- NOTES:** 1. Devices should not be operated at or outside these values. The "Recommended Operating Limits" provide for actual device operation.
2. ESD data available upon request.

RECOMMENDED OPERATING CONDITIONS

Characteristic	Symbol	Min	Typ	Max	Unit
Oscillator Frequency @ Pin 16	f_{osc}	495	500	505	kHz
Operating Temperature Range	T_A	0	–	+70	°C

MC34216A

DC ELECTRICAL CHARACTERISTICS (T_A = 25°C)

Characteristic	Symbol	Min	Typ	Max	Unit
VOLTAGE REGULATOR					
Regulated Supply at Pin 21 Startup Mode I _{CC} = 10 mA I _{CC} = 100 mA France and U.K. I _{CC} = 10 mA I _{CC} = 50 mA Low Voltage Mode (MC34216ADW Only) I _{CC} = 10 mA I _{CC} = 100 mA	V _{CC1} V _{CC2} V _{CC3}	4.25 4.40 4.25 4.30 3.60 3.75	4.50 4.65 4.50 4.55 3.90 4.05	4.75 4.90 4.75 4.85 4.20 4.35	Vdc
Current Consumption at Pin 21, Bit LD = Hi	I _{CC LD}	–	1.2	–	mA
Regulated Supply in Protection Mode, I _{CC} = 30 mA	V _{CC5}	4.30	–	4.80	Vdc
Reference Current @ Pin 20	I _{ref}	15.3	16.3	17.3	μA
LOGIC PINS					
Hook Status Output (Pin 17) Off–Hook, I _{out} = – 200 μA On–Hook, I _{out} = 200 μA Bit LD = 1, I _{out} = – 200 μA	V _{HSO1} V _{HSO2} V _{HSO3}	V _{CC} – 1.0 – V _{CC} – 1.0	– – –	– 0.4 –	Vdc
Reset Output (Pin 19) V _{CC} < 3.0 V V _{CC} > 3.25 V Hysteresis	V _{res(on)} V _{res(off)} V _{res(hys)}	– 3.0 –	– – 0.05	0.40 V _{CC} – 0.1 –	Vdc
SPEECH AMPLIFIERS					
Earpiece Amplifier DC Bias RXI, Pin 25 RXO1, Pin 26 RXO2, Pin 27 RXO1 – RXO2 Offset	V _{RXI} V _{RXO1} V _{RXO2} V _{offset}	1.7 1.7 1.7 –	– – – –	2.3 2.5 2.5 0.4	Vdc
Loudspeaker Amplifier LPI, Pin 24 LPO, Pin 23	V _{LPI} V _{LPO}	1.9 1.9	– –	2.5 2.5	Vdc
AHO1 (Pin 1) Normal Mode (HPI = 0) Supervision Mode (HPI = 1)	V _{AHO11} V _{AHO12}	1.15 2.2	– –	1.65 2.8	Vdc
AHO2 (Pin 2) Normal Mode (MicM = 1) V _{CC} = 3.5 (MicM = 0)	V _{AHO21} V _{AHO22}	1.15 –	– –	1.65 0.20	Vdc
Bias Voltage at HYN (Pin 10) Normal Mode Bit (LD = 1)	V _{HYN} V _{HYN-LD}	2.4 1.4	– –	2.7 1.7	Vdc
Microphone Amplifier Bias Voltage @ TXI (Pin 6) Voltage at MIC @ 1.0 mA (MicP = 1) Leakage @ MIC @ 4.5 V (MicP = 0)	V _{TXI} V _{Mic} I _{leak}	1.7 – –	– – –	2.0 0.35 5.5	Vdc μA
LAO (Pin 8) Maximum Current (Source) Maximum Current (Sink) Voltage (LD = 1, I = 100 μA) Driver A8 Slope	I ₈ I ₈ V _{LAO} S ₈	– 110 – 1.6	–150 150 – 2.1	–110 – 350 2.6	μA mV μA/mV
VO1 Follower (I ₂ = 0 μA) VO1 – VO2	VO1 ΔVO	1.1 40	1.18 80	1.3 120	V mV
Voltage at IMP (Pin 13)	V _{IMP}	2.2	–	2.5	Vdc

MC34216A

DC ELECTRICAL CHARACTERISTICS (continued) (T_A = 25°C)

Characteristic	Symbol	Min	Typ	Max	Unit
DC MASK CHARACTERISTICS					
Startup Mode					
Internal Slope	r _i	300	380	460	mV/μA
Voltage on SAI (I _{2C} = 5.9 μA)	V _C	800	–	–	mV
Voltage on SAI (I _{2D} = 7.1 μA)	V _D	–	–	1.5	V
Delta Offset Voltage on SAI (I _{2E} = 38 μA)	V _E – V _D	–	–	100	mV
French					
Internal Slope	r _i	76	103	130	mV/μA
Voltage on SAI (I _{2C} = 5.9 μA)	V _C	280	–	–	mV
Voltage on SAI (I _{2D} = 7.1 μA)	V _D	–	–	460	
Delta Offset Voltage on SAI (I _{2E} = 38 μA)	V _E – V _D	–	–	30	
U.K.					
Internal Slope	r _i	120	165	210	mV/μA
Voltage on SAI (I _{2C} = 5.9 μA)	V _C	420	–	–	mV
Voltage on SAI (I _{2D} = 7.1 μA)	V _D	–	–	675	
Delta Offset Voltage on SAI (I _{2E} = 38 μA)	V _E – V _D	–	–	40	
Low Voltage Mode (MC34216ADW Only)					
Internal Slope	r _i	95	129	165	mV/μA
Voltage on SAI (I _{2C} = 15 μA)	V _C	900	–	–	mV
Voltage on SAI (I _{2D} = 17 μA)	V _D	–	–	1.5	V _{dc}
Delta Offset Voltage on SAI (I _{2E} = 20 μA)	V _E – V _D	–	–	100	mV
Overvoltage Protection Threshold (V _{LAI} – V _{SAO}) I _{prot} = 60 μA, I _{CC} = 70 mA	V _{clamp1}	485	550	615	mV
Protection Voltage Level (V _{LAI} – V _{SAO}) I _{prot} = 60 μA	V _{clamp2}	370	410	450	mV

AC ELECTRICAL CHARACTERISTICS (T_A = 25°C)

Characteristic	Symbol	Min	Typ	Max	Unit
TRANSMIT MODE					
French and U.K.					
Maximum Transmit Gain (I ₂ = 5.6 μA)	K _{μ0}	13.5	14.5	15.5	dB
Line Length Regulation (I ₂ = 27.5 μA)	ΔK _μ	5.0	6.0	7.0	
Gain in Protection Mode (I ₂ = 29.5 μA)	K _{μp}	13.5	14.5	15.5	
Low Voltage Mode (MC34216ADW Only)					
Maximum Transmit Gain (I ₂ = 3.5 μA)	K _{μ0}	13.5	14.5	15.5	dB
Line Length Regulation (I ₂ = 7.7 μA)	ΔK _μ	4.7	6.0	7.3	
Gain in Protection Mode (I ₂ = 7.7 μA)	K _{μp}	13.5	14.5	15.5	
Gain Reduction when Microphone is Muted	ΔK _{mute}	60	–	–	dB
RECEIVE MODE					
French					
Maximum Internal Transconductance (I ₂ = 5.6 μA)	G _{e0}	203	230	258	μA/V
Line Length Regulation (I ₂ = 26 μA)	ΔG _e	5.0	6.0	7.0	dB
Protection Mode (I ₂ = 26 μA)	G _{ep}	203	230	258	μA/V
U.K.					
Maximum Internal Transconductance (I ₂ = 5.6 μA)	G _{e0}	203	230	258	μA/V
Line Length Regulation (I ₂ = 26 μA)	ΔG _e	5.0	6.0	7.0	dB
Protection Mode (I ₂ = 26 μA)	G _{ep}	203	230	258	μA/V
Low Voltage Mode (MC34216ADW Only)					
Maximum Internal Transconductance (I ₂ = 3.5 μA)	G _{e0}	183	210	241	μA/V
Line Length Regulation (I ₂ = 7.9 μA)	ΔG _e	4.7	6.0	7.3	dB
Protection Mode (I ₂ = 7.9 μA)	G _{ep}	183	210	241	μA/V
Earpiece Gain Reduction when Muted	ΔG _{e mute}	60	–	–	dB
Earpiece Gain Variation (EA Bit Changed to 1)	ΔG _{e1}	4.6	5.6	6.6	dB

MC34216A

AC ELECTRICAL CHARACTERISTICS (continued) (T_A = 25°C)

Characteristic	Symbol	Min	Typ	Max	Unit
TRANSMIT PABX MODE					
French and U.K. Transmit Gain (I ₂ = 2.0 μA) Variation with Line Length (I ₂ = 27 μA)	K _{PABX} ΔK _{PABX}	11.4 -0.5	12.5 -	13.6 0.5	dB
Low Voltage Mode (MC34216ADW Only) Transmit Gain (I ₂ = 2.0 μA) Variation with Line Length (I ₂ = 20 μA) Variation with Line Current (I _{CC} = 16 mA) Variation with Line Current (I _{CC} = 7.0 mA)	K _{PABX} ΔK _{PABX} ΔK _{PABX1} ΔK _{PABX2}	11.5 -0.5 -0.5 -2.0	12.5 - 0 0	13.6 0.5 0.5 2.0	dB

RECEIVE PABX MODE

French Internal Transconductance (I ₂ = 2.0 μA) Variation with Line Length (I ₂ = 27 μA)	G _{PABX} ΔG _{PABX}	157 -0.5	180 -	207 0.5	μA/V dB
U.K. Internal Transconductance (I ₂ = 2.0 μA) Variation with Line Length (I ₂ = 27 μA)	G _{PABX} ΔG _{PABX}	157 -0.5	180 -	207 0.5	μA/V dB
Low Voltage Mode (MC34216ADW Only) Internal Transconductance (I ₂ = 2.0 μA) Variation with Line Length (I ₂ = 20 μA) Variation with Line Current (I _{CC} = 16 mA) Variation with Line Current (I _{CC} = 7.0 mA)	G _{PABX} ΔG _{PABX} ΔG _{PABX1} ΔG _{PABX2}	152 -0.5 -0.5 -2.0	175 - - -	200 0.5 0.5 2.0	μA/V dB

DISTORTION

French and U.K. French	Transmit (I ₂ = 10–30 μA) Receive V _E = 700 mV (I ₂ = 10 μA) V _E = 1350 mV	THDT THDR	- - -	- - -	3.0 3.0 5.0	%
Low Voltage (MC34216ADW Only)	Transmit (I ₂ = 10–20 μA) Receive V _E = 700 mV (I ₂ = 20 μA) V _E = 1350 mV	THDT THDR	- - -	- - -	3.0 3.0 5.0	%

NOTE: V_E is the differential earpiece voltage across Pins 26 and 27.

OTHER ELECTRICAL CHARACTERISTICS (T_A = 25°C)

Characteristic	Symbol	Min	Typ	Max	Unit
LINE CURRENT AGC (R _{LS} = 25 Ω, G ₀ = G ₁ = G ₂ = 1, V _{LS} = 2.0 V _{pp} , French, U.K., and LV Masks)					
Line Current for which AGC is Active	I _{AGC(on)}	-	-	19	mA
V _{CC} with Current AGC "On" (I _{CC} = 13 mA)	V _{CC AGC}	V _{CC} - 5.0%	V _{CC}	-	Vdc
Line Current for which AGC is Inactive	I _{AGC(off)}	21	-	-	mA

PEAK-TO-PEAK AGC (R_{LS} = 25 Ω, C₂₅ = 220 nF, G₀ = G₁ = G₂ = 1, I_{CC} = 40 mA)

DC Level at Pin 28 AGC "Off" AGC "On"	V _{AGC(off)} V _{AGC(on)}	1.6 1.2	1.7 1.3	1.8 1.5	Vdc
AGC Upper Threshold France and U.K. Low Voltage (MC34216ADW Only)	V _{LS(up)}	V _{CC} - 1.2 0.85	V _{CC} - 1.0 1.0	- -	V _{rms}
AGC Lower Threshold France and U.K. Low Voltage (MC34216ADW Only)	V _{LS(low)}	V _{CC} - 1.9 0.72	V _{CC} - 1.6 0.85	- -	V _{rms}
1 Step AGC Gain Variation (LSB)	ΔAGC	1.0	1.25	1.50	dB

ANTI-HOWLING MONITORING RECEIVE GAIN

Internal Resistor R _T Muted (G ₂ , G ₁ , G ₀ = 000) Maximum Gain (G ₂ , G ₁ , G ₀ = 111)	R _{T000} R _{T111}	- 40	10 60	18 80	Ω kΩ
Attenuation Step	ΔG _{LS}	3.5	4.5	5.5	dB

MC34216A

OTHER ELECTRICAL CHARACTERISTICS (continued) (T_A = 25°C)

Characteristic	Symbol	Min	Typ	Max	Unit
RINGING MODE REGULATION					
Regulated V _{CC} (R _{LS} = ∞, I _{CC} = 10 mA)	V _{CCR}	5.15	5.5	5.8	Vdc
Current Consumption @ V _{CC} = 3.4 V, R _{LS} = ∞	I _{cR}	–	2.0	2.6	mA
Ringing Regulator Slope	g _R	4.8	6.3	7.8	μA/V
Peak Current @ V _{CC} = 4.2 V	I _R Peak	2.0	2.5	3.0	μA
Minimum V _{CC}	V _{CC0}	–	3.8	–	Vdc

MICROPHONE THRESHOLD

Transmit Gain Variation (M _{th(on)} /M _{th(off)}) I _u = 33 nA I _u = 110 nA	ΔK _{μmth1} ΔK _{μmth2}	– –0.5	7.0 0	– 0.5	dB
LS Gain Variation (M _{th(on)} /M _{th(off)}) I _u = 33 nA I _u = 110 nA	ΔG _{LSmth1} ΔG _{LSmth2}	–0.5 –	0 7.0	0.5 –	dB

SPEAKERPHONE MODE (G₂, G₁, G₀ = 111, Sp Bit = 1)

DC Level on Pin 1	V _{AHO1}	2.2	–	2.8	Vdc
Speakerphone Gain	G _{sp}	30	32	34	dB

MONITORING SIGNAL IN LOUDSPEAKER (R/S = 0, G₂, G₁, G₀ = 111)

DTMF Level SP = 0 Low Frequency High Frequency SP = 1 Low Frequency High Frequency	V _{LS-L1} V _{LS-H1} V _{LS-L2} V _{LS-H2}	– – – –	200 250 700 900	– – – –	mV
Pilot Tone (PT = 1) SP = 0 SP = 1	V _{LS-P1} V _{LS-P2}	– –	185 560	– –	mV
Idle Tone (IT = 1) SP = 0 SP = 1	V _{LS-I1} V _{LS-I2}	– –	145 700	– –	mV
Ring Tone (RT = 1) SP = 0 SP = 1	V _{LS-R1} V _{LS-R2}	– –	1100 1400	– –	mV

MONITORING SIGNAL IN EARPIECE (Single Ended)

DTMF Level Low Frequency High Frequency	V _{RXO-L} V _{RXO-H}	– –	12 15	– –	mV
Pilot Tone (PT = 1)	V _{RXO-P}	–	8.0	–	mV
Idle Tone (IT = 1)	V _{RXO-I}	–	6.0	–	mV

IDLE TONE ON LINE

Idle Tone Level (MFC01 = 11, MFO123 = 000)	I _{IDLE0}	400	550	700	nA
Step Size	I _{IDLE(step)}	–	62	–	nA

DTMF LEVELS

Level on LAI (Pin 9, I _{CC} = 20 to 70 mA, French and U.K. Masks) MFO123 = 1111, High Frequency Group MFO123 = 0111, High Frequency Group MFO123 = 0000, Low Frequency Group	I _{DTMF15} I _{DTMF12} I _{DTMF0}	1124 988 373	1336 1175 444	1586 1397 528	nA
High/Low Frequency Pre-Emphasis	G _{DTMF}	1.0	2.0	3.0	dB

NOTE: In low voltage mode, above levels must be reduced by 0.5 dB.

MC34216A

DTMF FREQUENCIES

Characteristic	Min	Typ	Max	Unit	DTMF Std	% Error
Low Group Frequencies	689.4	696.4	703.4	Hz	697	-0.09
	761.5	769.2	776.9	Hz	770	-0.10
	844.7	853.2	861.7	Hz	852	0.14
	930.5	939.9	949.3	Hz	941	-0.11
High Group Frequencies	1195.6	1207.7	1219.8	Hz	1209	-0.11
	1323.5	1336.9	1350.3	Hz	1336	0.07
	1464.5	1479.3	1494.1	Hz	1477	0.16
	1617.7	1634	1650.3	Hz	1633	0.06

NOTE: Minimum values based on $f_{OSC} = 495$ kHz. Maximum values based on $f_{OSC} = 505$ kHz.

TEMPERATURE SPECIFICATIONS ($T_A = 65^\circ\text{C}$)

Characteristic	Symbol	Min	Max	Unit
DTMF Distortion Level on Pin LAI, Delta Levels ($F = \text{Hi Freq} - f = 697$ Hz)	DTMFD	-	-27	dB
V_{CC2} in FR Mode @ $I_{CC} = 50$ mA	V_{CC2}	4.15	5.0	V
V_{CCR} @ $I_{CC} = 10$ mA, $RLS = \infty$	V_{CCR}	5.0	6.0	V
V_C on Pin SAI in FR Mode	V_C	220	460	mV
R_i Slope in FR Mode	R_i	65	155	k Ω
RT111 Resistor on LS in FR Mode	RT111	35	85	k Ω
$K_{\mu 0}$ in FR Mode	$K_{\mu 0}$	13	16	dB
G_{e0} in FR Mode	G_{e0}	170	270	$\mu\text{A/V}$
Reset Off @ $V_{CC} = 3.25$ V	V_{resoff}	3.0	3.25	V

PIN FUNCTION DESCRIPTION

Pin	Symbol	Description
1	AHO1	Anti-Howling Timing, Speakerphone Input
2	AHO2	Anti-Howling Timing, Low Voltage Line Driver Disable
3	MTF	Microphone Threshold Filtering
4	MTC	Microphone Threshold Timing
5	AGnd	Small Signal Ground
6	TXI	Microphone Amplifier Input
7	Mic	Microphone Bias Current Sink
8	LAO	Line Driver Amplifier Output
9	LAI	Line Driver Amplifier Input
10	HYN	Hybrid Network Input
11	NDC	Noise Decoupling
12	CM	DC Mask Signal Filtering
13	IMP	Reference Voltage
14	SAO	Line Current Sense Amplifier Output
15	SAI	Line Current Sense Amplifier Input
16	Osc	Oscillator Input. Connect to 500 kHz Resonator
17	D/HS	Data Input, Hookstatus Output
18	Clk	Clock Input
19	R_S	Reset Output
20	I_{ref}	Reference Current

MC34216A

PIN FUNCTION DESCRIPTION (continued)

Pin	Symbol	Description
21	V _{CC}	Supply Voltage
22	Gnd	Large Signal Ground
23	LPO	Loudspeaker Amplifier Output
24	LPI	Loudspeaker Amplifier Input
25	RXI	Receive Amplifier Input
26	RXO1	Receive Amplifier Output
27	RXO2	Receive Amplifier Output
28	AGC	Loudspeaker AGC Timing

CIRCUIT DESCRIPTION

Concept

With the MC34216A, a microcontroller and a switched mode power supply, a telephone set with listening-in function and ringing via loudspeaker can be built as shown in Figure 1.

In off-hook position, the application is in speech mode. The line current flows through transistor T2 and supplies the application at the supply point V_{CC} which is stabilized by the MC34216A. The V_{line}, I_{line} characteristic is programmed by the microcontroller and adjusted by the external components Z0, Z1, Z21 and R1 which are in a regulator loop, acting on transistor T2. The ac impedance is generated in a similar way. Handset and loudspeaker can be connected directly to the

MC34216A to perform handset and listening-in operation. Via the bus, the microcontroller programs the MC34216A to perform the DTMF/pulse-dialing and supervise the device. The user keyboard has to be connected to the microcontroller.

In on-hook position, the SMPS supplies the application in presence of a ringing signal. The microcontroller programs the MC34216A and a ringing melody can be generated via the loudspeaker.

The block diagram of the MC34216A (see Figure 2), shows the basic blocks of the device plus the essential external components.

Figure 1. Telephone Concept with MC34216A

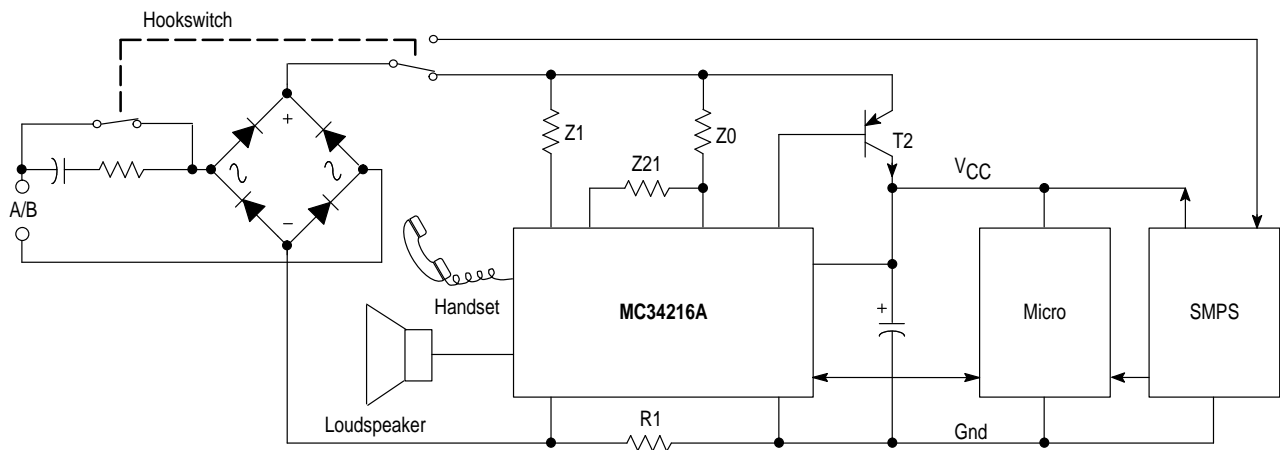

MC34216A

Figure 2. Block Diagram of the MC34216A with Essential Components

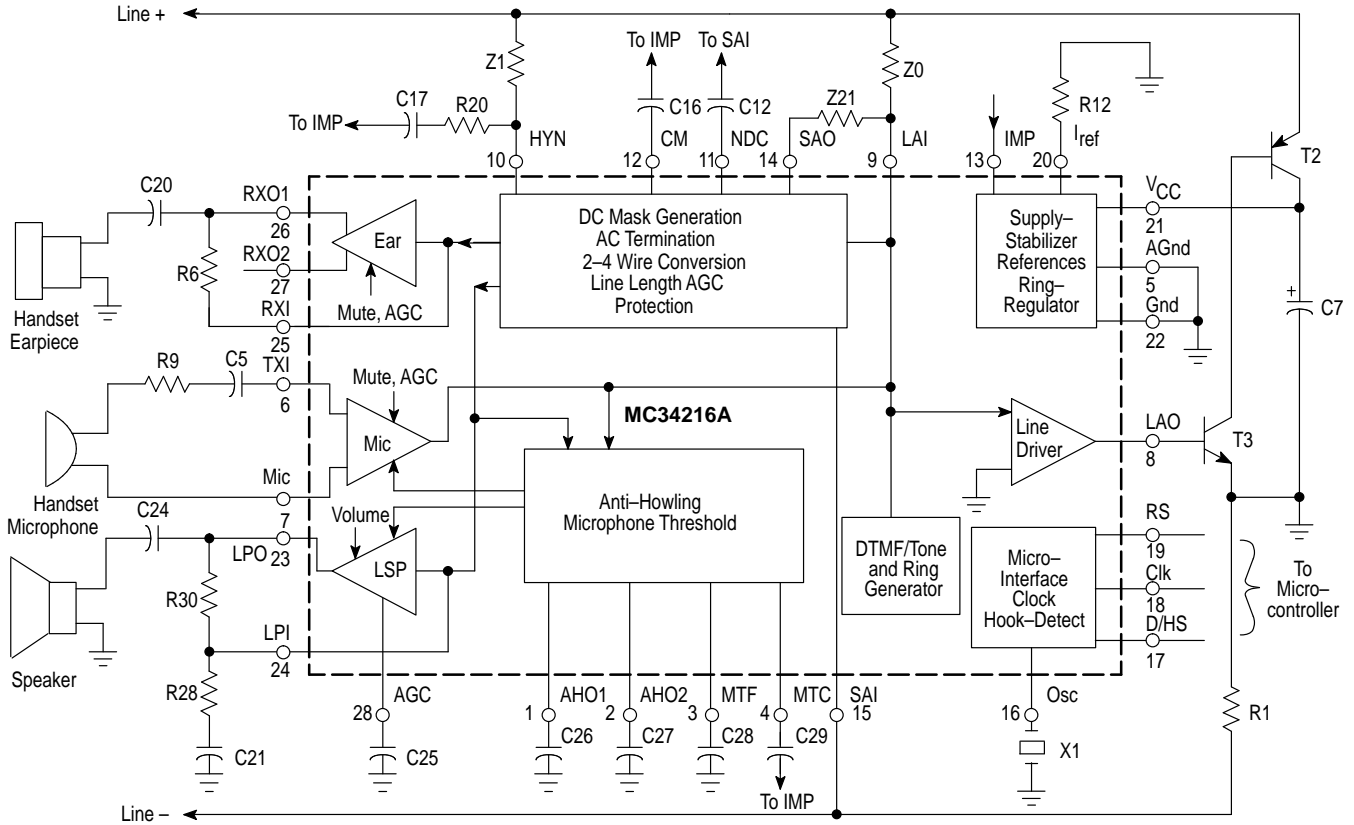

DC CHARACTERISTICS AND STARTUP

Figure 3. General Form of the DC Mask of the MC34216A

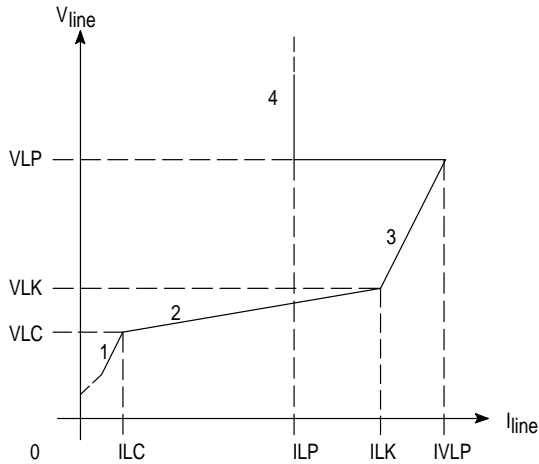

Region 1: Startup, Low Line Current, High Slope
 Region 2: Mid Range Line Current, Small Slope
 Region 3: High Line Current, High Slope
 Region 4: Overload Protection

adjustments. The software adjustments make it possible to program the 4 different basic masks: France, United Kingdom, Low Voltage and Startup. The hardware adjustments can be used for fine-tuning. The adjustment possibilities will be discussed below with the aid of the block diagram of Figure 4.

In Region 1, the transfer of the amplifier G at the HYN input equals zero. The voltage difference between SAO and SAI will equal V_{O1} . The slope R_{E1} of the V_{line} , I_{line} characteristic will equal:

$$R_{E1} = R1 \times \left(1 + \frac{Z0}{Z21} \right)$$

In Region 2, the output current of the amplifier G will be proportional to the input current. As a result, the voltage between SAO and SAI will increase with the line voltage. Speech signals on the line are of no influence on this because they are filtered out via capacitor C16. The slope R_{E2} of the V_{line} , I_{line} characteristic will equal:

$$R_{E2} = R1 \times \left[1 + \frac{1}{\frac{Ri}{Z1} + \frac{Z21}{Z0}} \right]$$

In Region 3, the output current of the amplifier G is kept constant. As a result, the slope in Region 3 will equal the slope of Region 1.

The MC34216A offers the possibility to adjust the dc characteristics of all 4 regions via both software and hardware

Figure 4. DC Part of the Block Diagram of the MC34216A

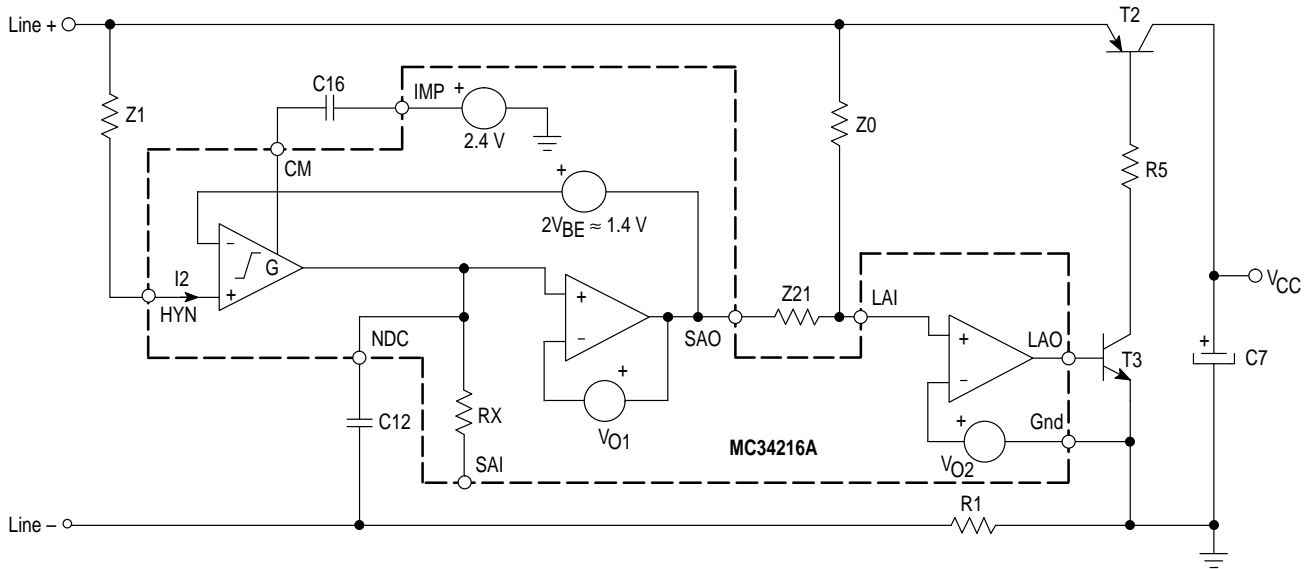

The transfer from Region 2 to 3 occurs at the point VLK, ILK, which is calculated:

$$VLK = Z1 \times I2CD + 2V_{BE} + V_{CD} + V_{O2}$$

$$ILK = \frac{Z21}{Z0} \times \left(Z1 \times I2CD + 2V_{BE} \right) + V_{CD}$$

$$\text{With : } I2CD = \frac{I2C + I2D}{2}, \text{ and } V_{CD} = \frac{V_C + V_D}{2},$$

$$\text{and } 2V_{BE} \approx 1.4 \text{ V}, V_{O2} \approx 1.1 \text{ V}$$

When the French or U.K. mask is selected, this transfer takes place for line currents of 30 mA to 40 mA depending on the components settings. With the Startup and Low Voltage mask, the transfer lies outside the normal operating range with line currents of 90 mA or more. In most applications, the transfer from Region 1 to 2 takes place for line currents below 10 mA.

With proper settings, Region 4 is only entered during an overload condition. In this mode, the power consumption in the telephone set is limited. In order to detect an overload condition, the voltage between the Pins LAI and SAO is monitored. When the voltage difference is larger than the threshold V_{clamp1} , the protection is made active. The relation for the line voltage VLP at this point is given as:

$$VLP = \frac{Z0}{Z21} \times V_{clamp1} + V_{CD} + V_{O2}$$

When the protection mode is entered, the line current is reduced to a lower value ILP of:

$$ILP = \frac{V_{clamp2} + (V_{O1} - V_{O2})}{R1}$$

When the line voltage becomes smaller than VLP, the overload condition is gone and the MC34216A will leave Region 4.

The current drawn from the line by the dc part is used to supply the MC34216A and peripheral circuits. The surplus of current is sunk away by the voltage stabilizer at Pin V_{CC} where a reservoir capacitor is connected. The reference for the circuit is Pin Gnd.

Startup of the application is ensured by an internal startup circuit. During the startup, the internal registers of the MC34216A are reset, and the reset Pin R_S goes high. This signals is meant to indicate to the microcontroller that the programming of the MC34216A can start.

When the line current flows, the hook status output Pin D/HS goes high. This serves as the information for the microcontroller that the set is off-hook. When the line current is no longer present, the pin goes low again. Because the line current is monitored, and not the line voltage, an interrupt of the exchange can be recognized.

AC CHARACTERISTICS

Impedance

In Figure 5, the block diagram of the MC34216A performing the ac impedance is depicted. As can be seen, it is partly in common with the dc mask block diagram. The part generating the dc mask is replaced by a dc voltage source because for ac, this part has no effect.

Figure 5. AC Stage of the MC34216A

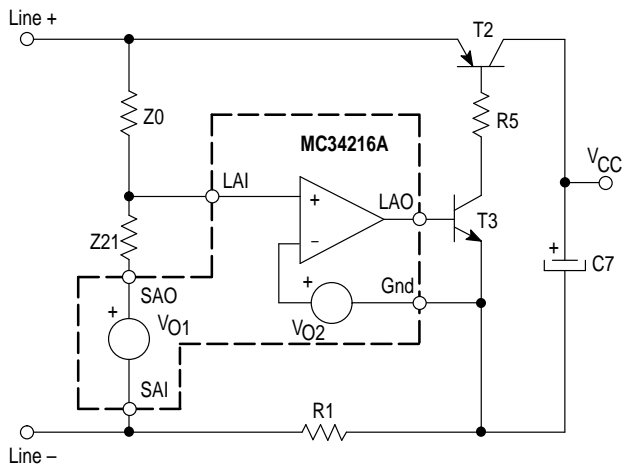

When calculating the ac loop, it can be derived that the set impedance Z_{in} equals:

$$Z_{in} = \frac{V_{line}}{I_{line}} = R1 \left(1 + \frac{Z0}{Z21} \right) \approx R1 \times \frac{Z0}{Z21}$$

As can be noticed, the formula for the ac impedance Z_{in} equals the formula for the dc slope in Regions 1 and 3. However, because for the dc slopes the resistive part of $Z0$ and $Z21$ are used, the actual values for Z_{in} and the dc slopes do not have to be equal.

A complex impedance can be made by making either $Z0$ or $Z21$ complex. When $Z0$ is made complex to fit the set impedance, the transmit characteristics will be complex as well. The complex impedance is therefore preferably made via the $Z21$ network. Because $Z21$ is in the denominator of the Z_{in} formula, $Z21$ will not be a direct copy of the required impedance, but a derivative of it. Figure 6 shows the derived network to be used for $Z21$.

Figure 6. Derived Network for Z21 in Case of Complex Set Impedance

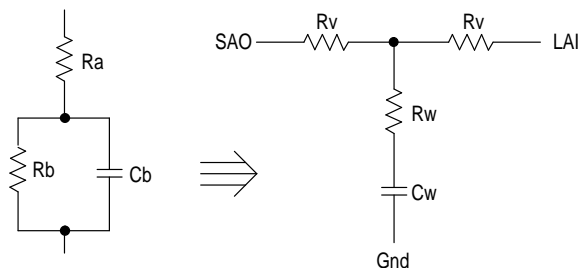

$$Rv = \frac{R1 \times Z0}{2(Ra + Rb - R1)}$$

$$Rw = \frac{R1 \times Z0 (Ra - R1)}{4Rb (Ra + Rb - R1)}$$

$$Cw = \frac{4Rb^2 \times Cb}{R1 \times Z0}$$

Transmit

When on Pin LAI a current is injected, via the loop depicted in Figure 5, a signal is created on the line. In this way, the microphone signals and DTMF signals from the internal generator are transmitted. It can be derived that the signal voltage on the line (V_{line}) depends on the signal current injected in LAI (I_{LAI}) according to:

$$V_{line} = -I_{LAI} \times \frac{Z0 \times Z_{line}}{Z_{in} + Z_{line}}$$

With this relation, a simplified replacement circuit can be made for the transmit amplifier (see Figure 7). Here the product of I_{LAI} and $Z0$ is replaced by one voltage source.

Figure 7. Replacement Diagram for the Transmit Amplifier

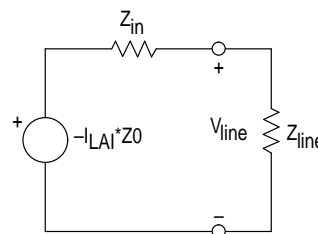

The microphone signal current is derived from the microphone signal according to the schematic in Figure 8.

Figure 8. Microphone Amplifier Input Stage

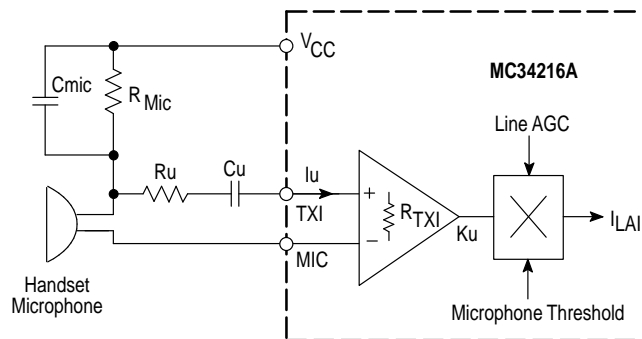

The input stage in Figure 8 consists of a current amplifier with transfer Ku and impedance $R_{TXI} = 1.0 \text{ k}\Omega$ plus an attenuator which reduces the signal current at high line currents, the so-called line length regulated gain or line AGC. This attenuator can be switched on/off via the microcontroller. The input current I_u within the telephony speech band is derived from the microphone signal according to:

$$I_u = \frac{V_u}{R_{Mic} + R_u + R_{TXI}} \approx \frac{V_u}{R_u}$$

With: V_u = signal of the microphone only loaded with R_{Mic} . The overall gain from microphone to line (A_{TX}) now follows as:

$$A_{TX} = \frac{V_{line}}{V_u} = \frac{Ku}{R_u} \times \frac{Z0 \times Z_{line}}{Z_{in} + Z_{line}}$$

Practically, the gain can only be varied with $Z0$, R_u and R_{Mic} .

Figure 9. Receive Part of the MC34216A

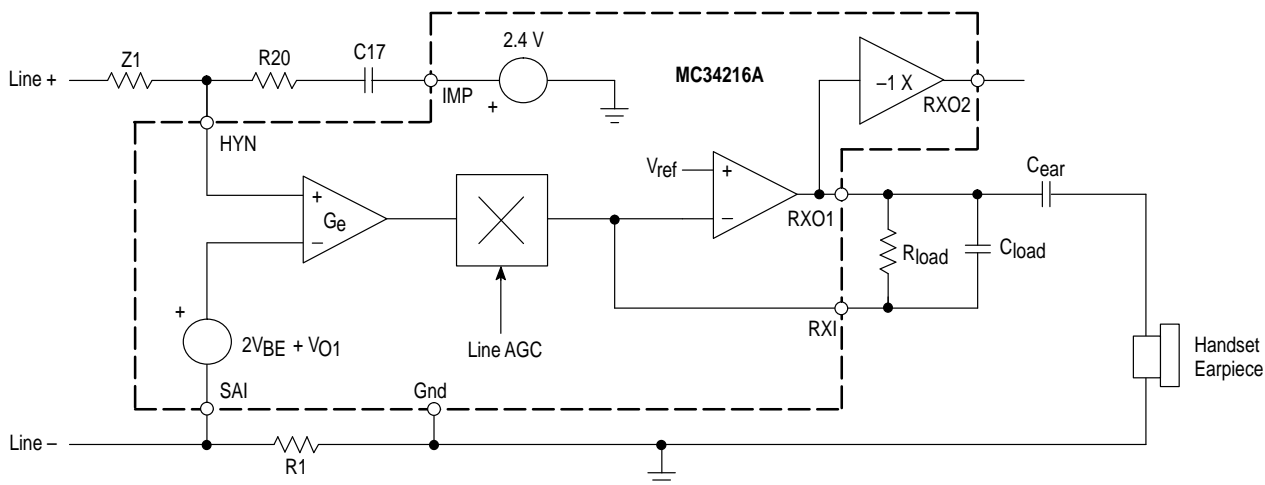

The noise which is transmitted to the line can be reduced when the microphone threshold feature is enabled. This is also called squelch. When there is no microphone signal present, the transmit gain is reduced by 7.0 dB with respect to nominal. In between, the gain is varied in steps of 1.0 dB dependent on the signal level. The detection of the microphone signal level is done via an integrator which uses the external capacitors C28 and C29 for timing and filtering. This feature is also very useful to reduce the howling effect during listening-in.

The MC34216A offers the possibility to mute the microphone, also called privacy mode. In this case, the far end user no longer hears the local user. It is possible to send during this mode an idle tone to the line to make the far end user aware of this.

During pulse-dialing, the microphone biasing can be switched off by programming. Pin Mic will then be made high impedance, meaning that the microphone dc current no longer flows into this pin. This reduces the current consumption of the application during pulse-dialing. It can also be used to disconnect the handset microphone signal and enable another transmit signal, for instance from a handsfree microphone.

Receive

The receive portion of the MC34216A is shown in Figure 9.

The receive signal is picked up by the amplifier at the HYN input. This is the same amplifier as present in the dc loop of Figure 4. The signal is first converted to current by the transconductance amplifier with transfer G_e . The multiplier placed after performs line length dependent gain or line AGC. Afterwards, the current is converted back to voltage via the external feedback network Z_{load} . The resulting voltage is available at output RXO1, and at RXO2 which is the inverted earpiece output.

From the diagram of Figure 9 the receive gain (A_{RX}) can be derived as:

$$A_{RX} = \frac{V_{RXO}}{V_{line}} = G_e \times R1 \times Z_{load} \times \left(\frac{1}{Z_h} + \frac{1}{Z_{in}} \right)$$

$$\text{With: } Z_h = \frac{R1 \times Z1}{R20},$$

The earpiece can either be connected as a single-ended or as a bridge-tied load. The above calculated gain is valid for the single-ended case. When connecting as a bridge-tied load, the gain is increased by 6.0 dB.

The MC34216A offers the possibility to increase the receive gain to the earpiece with an extra 6.0 dB via the microcontroller on command of the user of the telephone set. This is useful for people with hearing problems or when the far end user speaks very softly.

The MC34216A offers the possibility to mute the signal coming from the line to the earpiece. This is useful during pulse-dialing or to mute the far end user.

Sidetone

When a transmit signal is transmitted to the line, a part of the signal is returned to the receive channel due to the nature of the 2 to 4 wire conversion of the hybrid. During transmit, the signal on the line will be $-I_{line} \times Z_{line}$. During receive, the signal on the line will be $I_{line} \times Z_{in}$. When replacing Z_{in} in the formula for the receive gain, it follows that the signal on the earpiece output due to a sending signal on the line will be:

$$\frac{V_{ear}}{V_{line-transmit}} = G_e \times R1 \times Z_{load} \times \left(\frac{1}{Z_h} - \frac{1}{Z_{line}} \right)$$

The sidetone can be minimized by making Z_h equal to Z_{line} . A complex sidetone network can therefore be made via a complex Z1. The coupling capacitor C17 in series with R20 is only meant to block dc.

Line Length AGC

The MC34216A offers the possibility to vary the transmit and receive gains over line length in order to compensate for the loss in gain at longer line lengths. In the block diagrams of the transmit and receive channels the attenuator performing the line AGC is already drawn. The line AGC can be switched on/off via the microcontroller. In case the line AGC is switched off, the transmit and receive gain are lowered 2.0 dB with respect to the value calculated via the formulas above.

The line AGC characteristics for both transmit and receive channels have the general shape depicted in Figure 10.

also see the sidetone characteristics below.

Figure 10. General Line AGC Characteristics

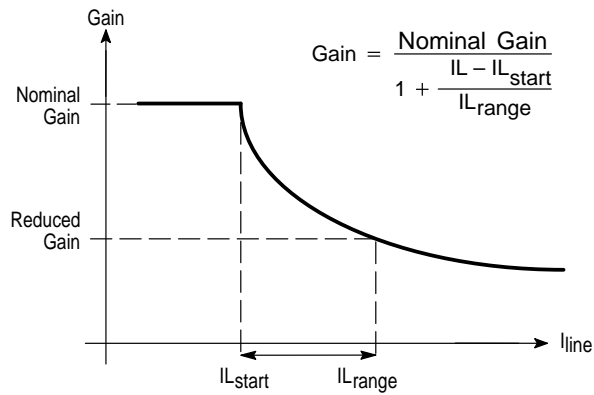

For small line currents, and thus long lines, the gains are nominal. When the line current has increased above I_{L_start} with a current I_{L_range} , the gain is reduced by 6.0 dB. Due to the general characteristics of the line AGC curve, the gain will be decreased further for higher currents.

For France and the U.K., the line AGC will be active in Region 3 of the dc characteristics. The I_{L_start} is approximately equal to the I_{LK} . The range is determined by:

$$I_{L_range} = \frac{Z_1 \times (I_{2R} - I_{2CD})}{R_{E3}}$$

For Low Voltage mask, the line AGC is active in Region 2.

Loudspeaking Facility

The MC34216A incorporates a loudspeaking facility which facilitates group listening-in with incorporated anti-howling circuitry, handsfree conversation with external duplex controller and ringing via loudspeaker with external switched mode power supply.

Loudspeaker Amplifier

The block diagram of the loudspeaker amplifier which is incorporated in the MC34216A is depicted in Figure 11.

The first part of the loudspeaker amplifier equals the receive part of the earphone amplifier. It therefore also includes the anti sidetone circuit and the line current AGC. The overall gain from line to loudspeaker output LPO is therefore:

$$A_{LSP} = \left(1 + \frac{R_{30}}{R_{28}} \right) \times R_T \times G_e \times R_1 \times \left(\frac{1}{Z_h} + \frac{1}{Z_{in}} \right)$$

The gain of the loudspeaker amplifier can be adjusted by the external components as indicated in the formula above. However, the gain is also influenced by line length AGC, volume control and the signal limiter AGC.

The influence of line length AGC on the loudspeaker channel is equal to its influence on the receive amplifier of the earpiece because it is in their common path.

The volume of the loudspeaker is controlled via the microcontroller. In total, 8 levels can be programmed: 7 levels with equal steps of 4.5 dB and one level which completely mutes the loudspeaker amplifier.

The output signal is limited by an AGC circuit when the peaks of the signal are larger than a certain threshold (peak AGC) and when the line current available is not sufficient (current AGC). This prevents distortion of the output signal and a drop of the supply voltage V_{CC} .

Listening-In

During group listening-in, both the handset and the loudspeaker are active. Via the acoustic coupling from loudspeaker to handset microphone, howling can occur when the handset is held close to the base. In order to reduce howling, an anti-howling correlator and a microphone threshold are incorporated in the MC34216A. Both functions can be switched on/off via the microcontroller.

The anti-howling correlator monitors the microphone and loudspeaker signal via capacitors C26 through C29. When both signals show a high correlation, then both contain a common signal. In practice, this means that howling is present. In this case, the anti-howling correlator will reduce the loudspeaker gain in steps of 1.25 dB, until the correlation is below a certain threshold.

Figure 11. Block Diagram of the Loudspeaker Amplifier

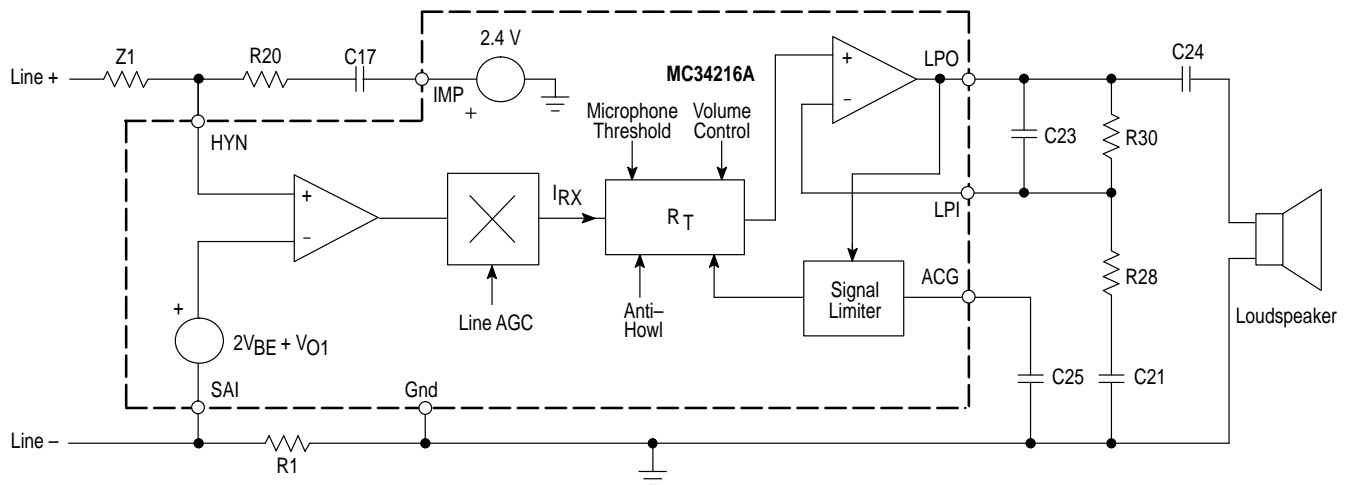

The microphone threshold reduces the gain in the acoustic feedback loop by 7.0 dB. When there is no, or only a small microphone signal, the gain in the transmit path is reduced by 7.0 dB with respect to nominal. The loudspeaker gain is then at its nominal value. At a high microphone input current, the microphone gain is back to its nominal value and the loudspeaker gain reduced by 7.0 dB. The behavior of the microphone threshold feature is depicted in Figure 12.

Figure 12. Behavior of the Microphone Threshold Feature

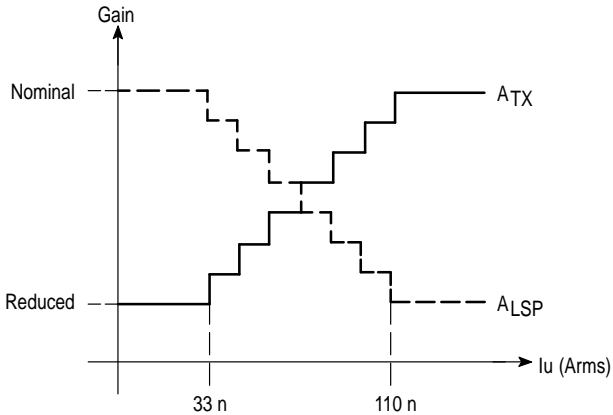

Handsfree

A speakerphone application for handsfree conversation can easily be made with the MC34216A by adding one of the Motorola speakerphone cores to it. The TX1 input can be used to amplify the transmit signal and the earphone output can be used to monitor the receive signal. The receive output of the speakerphone core can be connected to AHO1. When programming the MC34216A in speakerphone

mode, the signal on this pin will be amplified to the loudspeaker output. In this way, the features and functionality of the MC34216A are optimally used, like its powerful supply, loudspeaker amplifier with anti-distortion circuitry and line current regulation. More details about this application can be found in the user manual.

Ringling

The MC34216A offers the possibility to generate a ringing melody via the loudspeaker, which avoids the use of a piezo buzzer. The power needed to supply the loudspeaker is transformed out of the ringer signal by a switched mode power supply TCA3385. The melody is generated by the MC34216A and programmed via the microcontroller. This concept is depicted in Figure 13.

As can be seen in Figure 13, the high voltage ring signal is first transformed into a low voltage supply point with high current capability. This is needed because, compared to a piezo resonator, a loudspeaker is low ohmic. In the ringing mode, the voltage of the supply point is stabilized by the MC34216A to 5.5 V. The ringing melody can be programmed via the microcontroller and is generated internally. The output signal level is regulated via a gain control loop. The loop couples the value of VCC to the output current of the ringing melody generator. No ringing melody is made audible when VCC is below 3.8 V and the maximum volume is reached when VCC has reached 5.5 V.

To ensure optimum output power under low line current conditions, the current consumption of the MC34216A in ringing mode is reduced down to 2.0 mA.

The MC34216A offers the possibility to listen to the ringing melody while in the speech mode. Although the feeding conditions are not equal for ringing and speech mode, this offers the user the possibility to program his own melody and to adjust the volume.

Figure 13. Concept of Ringling Via Loudspeaker

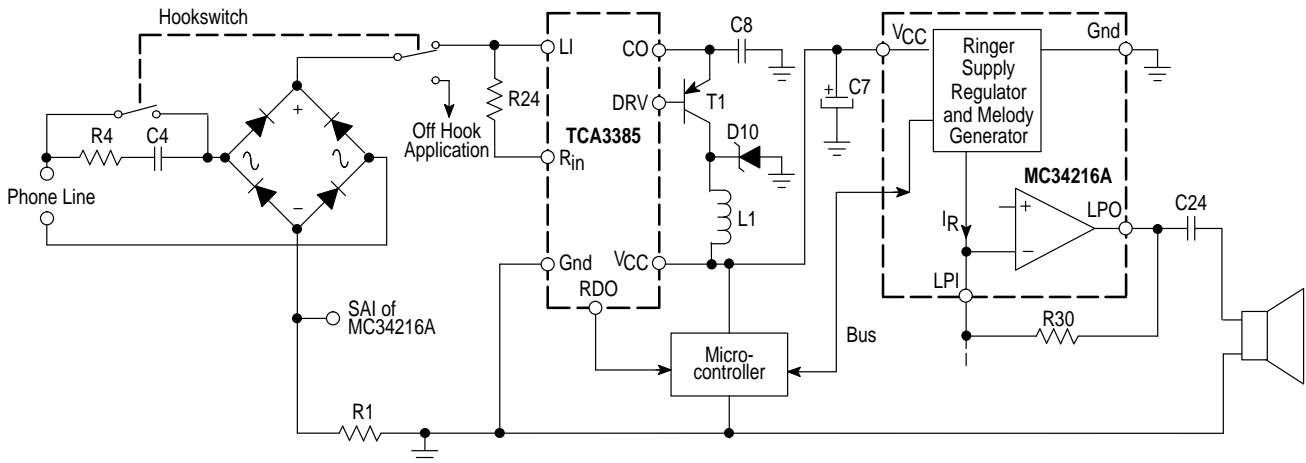

MC34216A

Programming Possibilities

The MC34216A can be programmed by a microcontroller via a 2 wire bus. In this way, it is possible to program the dc mask, DTMF tones, listening-in mode, loudspeaker volume, etc.

The bus interface of the microcontroller with the MC34216A consists of 2 wires: a data wire and a clock wire connected to Pins D/HS and CLK respectively. Also, the reset Pin RST of the MC34216A is connected to the microcontroller. The MC34216A itself has a local oscillator connected to Pin Osc.

The local oscillator needs a 500 kHz parallel mode ceramic resonator, with approximately 75 pF capacitance, connected to ground (for instance, the TOKO FCRK500A-P35). The local oscillator is the reference for all the internal timings of the MC34216A.

The 2 wire bus is based on the SCI standard. This standard includes things such as de-bouncing and bus monitoring in order to check that the data is sent over correctly. The full bus specification is depicted in Figure 14. The data is read in during the falling edge of the clock signal. The clock has to be active only during the transfer of the data. After the data is sent, the clock has to be kept low.

The D/HS pin is not only the input for the data but also the output for the hookswitch information. When there is line current flowing, this pin will be high, provided that the clock line is low.

The reset Pin RST of the MC34216A is high for supply voltages on V_{CC} of 3.1 V and higher. It is the indication for the microcontroller that programming of the device is possible. When RST becomes high and D/HS is high as well, the microcontroller can start programming the registers for the speech mode. When information from the ringer indicates that there is a ring signal present on the line, the microcontroller can start programming the registers for ringing mode.

The registers of the MC34216A are 8-bits wide. The register bits are shown in Figure 15. The 8-bits can be split up into 2 address bits and 6 data bits of the format A1A0D5D4D3D2D1D0. Data is sent over starting with the address bits (A1 and A0) and then the data bits, D5 through D0.

During startup of the MC34216A, the registers are internally reset in order to have a defined state. The contents of the registers after the reset are also given in Figure 15. In summary, it starts up with LV mask and handset mode with the transducers muted.

Figure 14. Bus Specification

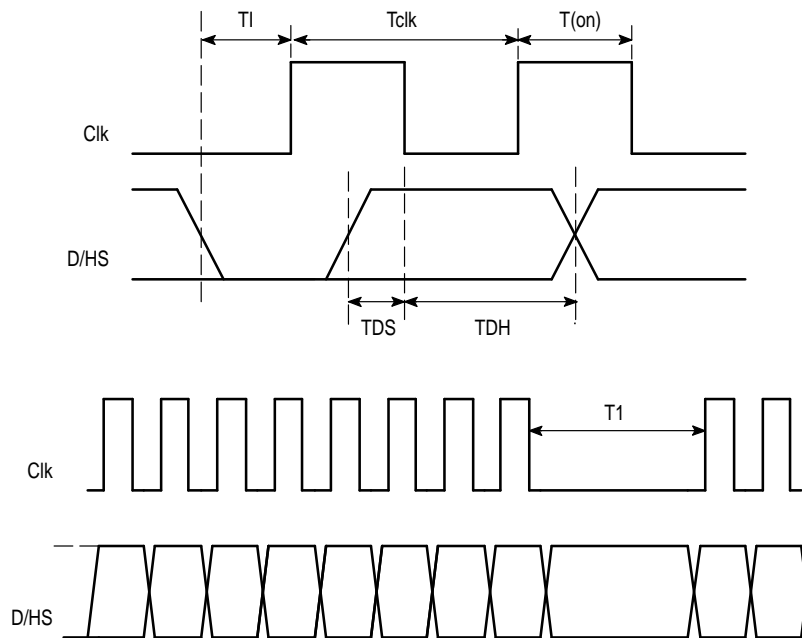

Symbol	Description	Min	Max	Unit
Tclk	Clock Period	125	1000	μ s
T(on)	High Level Duration	66	–	μ s
TDS	Data Setup Time	10	Ton	μ s
TDH	Data Hold Time	20	900	μ s
TD	Debounce Time	16	–	μ s
TI	Data Reset Time to First Clock Rising Edge	40	–	μ s
T1	Interval Between 2 Successive 8-Bit Words	700	–	μ s
Vihc	High Input Level – Clock	0.7	5.0	Vdc
Viic	Low Input Level – Clock	0.0	0.3	Vdc
Vihd	High Input Level – Data	1.7	5.0	Vdc
Viid	Low Input Level – Data	0.0	1.2	Vdc

Figure 15. Register Description

Address	Data	Symbol	Function	State at Reset
A1, A0 = 00	D0	MicM	Microphone Mute	0 = Muted
	D1	EM	Earphone Mute	0 = Muted
	D2	LD	Loop Disconnect	0 = Loop Closed
	D3	PT	Pilot Tone	0 = Tone "Off"
	D4	IT	Idle Tone	0 = Tone "Off"
	D5	MicP	Microphone Power	0 = Power "Off"
A1, A0 = 01	D0	MFC0	Tone Control	0, See Tables Below
	D1	MFC1	Tone Control	0, See Tables Below
	D2	MF0	Tone Select	0, See Tables Below
	D3	MF1	Tone Select	0, See Tables Below
	D4	MF2	Tone Select	0, See Tables Below
	D5	MF3	Tone Select	0, See Tables Below
A1, A0 = 10	D0	R/S	Ring/Speech Mode	0 = Speech Mode
	D1	EA	Earphone Gain 6.0 dB	0 = Nominal Gain
	D2	G0	Loudspeaker Gain	0, See Tables Below
	D3	G1	Loudspeaker Gain	0, See Tables Below
	D4	G2	Loudspeaker Gain	0, See Tables Below
	D5	RT	Ring Tone	0 = Tone "Off"
A1, A0 = 11	D0	DCM0	DC Mask Control	0, See Tables Below
	D1	DCM1	DC Mask Control	1, See Tables Below
	D2	Sp	Speakerphone Mode	0 = "Off"
	D3	GR	Line Length Regulation	0 = "On"
	D4	HPI	Anti-Howling	0 = "On"
	D5	M _{th}	Microphone Threshold	0 = "On"

MFC1	MFC0	Function
0	0	Switch DTMF Generation "Off"
0	1	Select DTMF-Pair and Generate
1	0	Select Pilot/Idle/Ring Tone Frequency
1	1	Select DTMF/Idle Tone Level (Level I _{LA})
DCM1	DCM0	Function
0	0	Startup Mask for France
0	1	U.K. Mask
1	0	Low Voltage Mask
1	1	French Mask

G2	G1	G0	Function
0	0	0	Loudspeaker Amplifier Muted
0	0	1	Gain Reduction 27.0 dB
0	1	0	Gain Reduction 22.5 dB
0	1	1	Gain Reduction 18.0 dB
1	0	0	Gain Reduction 13.5 dB
1	0	1	Gain Reduction 9.0 dB
1	1	0	Gain Reduction 4.5 dB
1	1	1	No Attenuation, Nominal Gain

Figure 16. Register Description

MF3	MF2	MF1	MF0	MFC1 = 0, MFC0 = 1			MFC1 = 1, MFC0 = 0
				DTMF-Pair (in Hz)			Single Tone (in Hz)
				Low	High	Key	
0	0	0	0	941	1633	D	440
0	0	0	1	941	1477	#	494
0	0	1	0	941	1336	0	523
0	0	1	1	941	1209	*	554
0	1	0	0	852	1633	C	587
0	1	0	1	852	1477	9	622
0	1	1	0	852	1336	8	659
0	1	1	1	852	1209	7	698
1	0	0	0	770	1633	B	784
1	0	0	1	770	1477	6	880
1	0	1	0	770	1336	5	988
1	0	1	1	770	1209	4	1047
1	1	0	0	697	1633	A	1319
1	1	0	1	697	1477	3	1661
1	1	1	0	697	1336	2	1760
1	1	1	1	697	1209	1	2093

The dc mask of the MC34216A can be programmed to fit the different country requirements. During startup, this will be the first register which has to be programmed in order to have a dc setting as soon as possible.

The pulse-dialing is timed by the microcontroller (make/brake ratio, inter-digit pause) by making the LD bit high and low. Also, memory dialing or last number redial can be done. During LD = 1, the MC34216A makes its output LAO low for the line break and reduces its internal current consumption. The current through the microphone can be stopped also by making bit MicP low.

The transmit path can be muted by making the MicM bit low. It effectively mutes both the signal from the handset microphone as well as the signal coming from a speakerphone circuit. During this microphone mute state, a

melody can be sent to the line (melody on hold). In order to enable the idle tone function, the IT bit has to be made high. The squelch function can be enabled by making the M_{th} bit low. The line AGC feature can be enabled by making the GR bit low.

The receive path can be muted by making the EM bit low. It effectively mutes both the signal from the line to the handset earpiece as well as to the loudspeaker output. During this mute state, a pilot tone melody can be sent to the earpiece or loudspeaker. This is very useful during pulse-dialing, programming of telephone numbers in memories or during operation of an answering or fax machine. In order to enable the pilot tone function, the PT bit has to be made high. The gain of the earphone amplifier can be increased by 6.0 dB by making the EA bit high.

MC34216A

The MC34216A incorporates a DTMF generator with integrated filters. The DTMF pairs can be selected by the microcontroller via the MF bits. In this way, the whole DTMF range for a 4x4 keyboard is available which fulfills the CCITT requirements. The DTMF level on the line can be adjusted by external components and it can also be programmed via the MF bits.

For listening-in operation, the loudspeaker has to be switched on and the anti-howling circuitry has to be activated. The loudspeaker is switched on by making the G2G1G0 bits high. They also set the volume. The anti-howling circuit is activated by making bit HPI low. By making bit M_{th} high, the microphone threshold feature is enabled which further reduces the effect of howling.

By making the SP bit high, the speakerphone mode is programmed. This automatically disables the earpiece by muting the RXO2 output, and it enables the AHO1 input as a speakerphone signal input. By making the MicP bit low, the handset microphone is no longer powered and is thus muted. This ensures that only the signal from the base microphone is transmitted to the line.

By making the R/S bit high, the ringing mode is programmed. The ringing melody is programmed via the microcontroller and generated by the MC34216A. The volume can be programmed via the 3 loudspeaker gain bits G2G1G0. The ring melody is enabled by making the ring tone switch R_T high. The melody can be tested during normal speech mode by activating the ring tone switch R_T while R/S is low.

The answering machine mode is entered by making the R/S bit high. This enables the microphone, earphone and loudspeaker amplifiers while the set is on-hook. This makes

it possible to record a message with the handset microphone and to playback messages via the earpiece or loudspeaker. Other blocks of the circuit are not activated. During off-hook operation, the incoming messages can be recorded and the outgoing message can be played in the normal way. More details about the answering machine application can be found in the user manual.

Support Material

Device Specification:	Brief description of the MC34216A, block diagram, device data, bus specification, test diagram, typical application
User Manual MC34216A:	Extended description of the circuit and its concept, description of the programmability, adjustment procedure, application hints and proposals
Demonstration Board:	Performance of the MC34216A is shown in an application with the TCA3385 switched mode power supply and a MC68HC705 microcontroller
Adjustment Software:	A QBASIC program which helps the customer to find the right component values for fulfilling the requirements
Register Display Board:	Visualizes the register contents which are transmitted on the demonstration board by means of LEDs

Figure 17. Typical Application

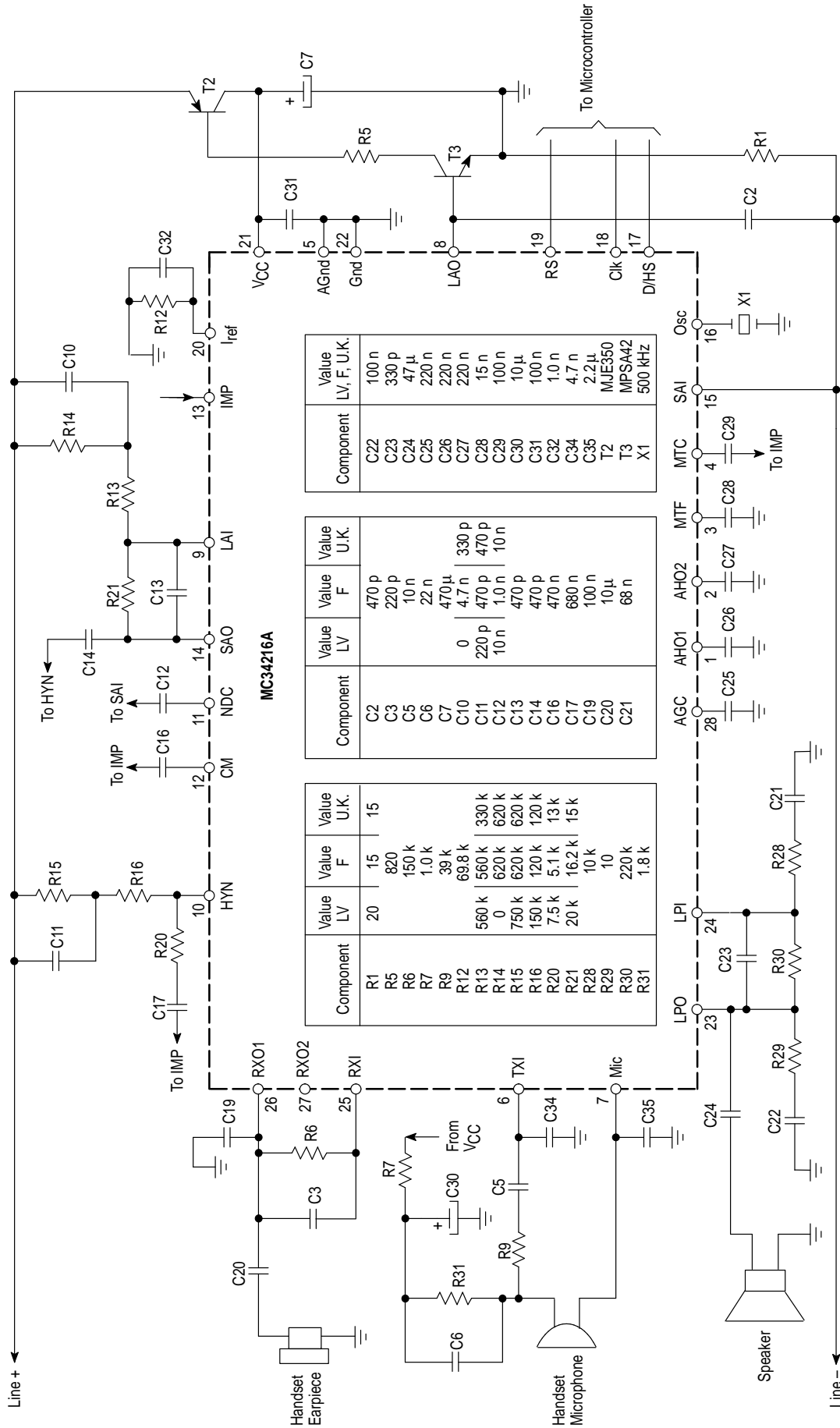

LV = Low Voltage Mode
 F = France
 U.K. = United Kingdom

MC34216A

OUTLINE DIMENSIONS

DW, DWF SUFFIX
PLASTIC PACKAGE
CASE 751F-04
ISSUE E

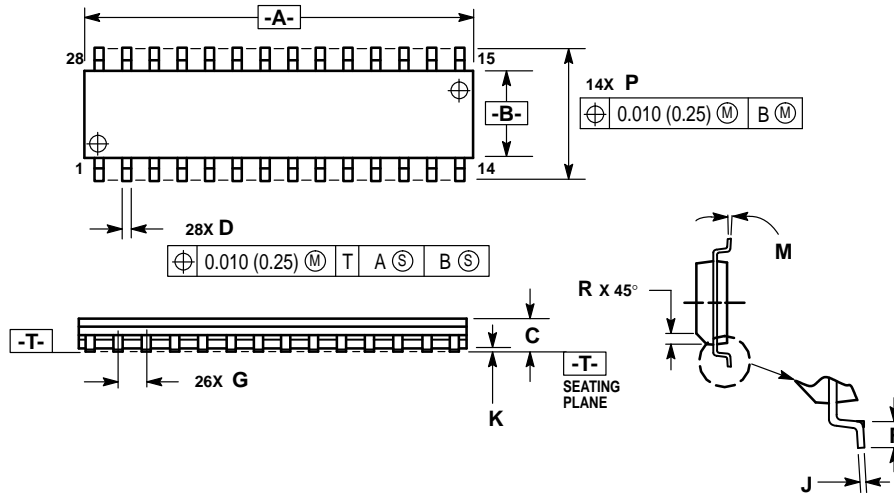

NOTES:

1. DIMENSIONING AND TOLERANCING PER ANSI Y14.5M, 1982.
2. CONTROLLING DIMENSION: MILLIMETER.
3. DIMENSION A AND B DO NOT INCLUDE MOLD PROTRUSION.
4. MAXIMUM MOLD PROTRUSION 0.15 (0.006) PER SIDE.
5. DIMENSION D DOES NOT INCLUDE DAMBAR PROTRUSION. ALLOWABLE DAMBAR PROTRUSION SHALL BE 0.13 (0.005) TOTAL IN EXCESS OF D DIMENSION AT MAXIMUM MATERIAL CONDITION.

DIM	MILLIMETERS		INCHES	
	MIN	MAX	MIN	MAX
A	17.80	18.05	0.701	0.711
B	7.40	7.60	0.292	0.299
C	2.35	2.65	0.093	0.104
D	0.35	0.49	0.014	0.019
F	0.41	0.90	0.016	0.035
G	1.27 BSC		0.050 BSC	
J	0.23	0.32	0.009	0.013
K	0.13	0.29	0.005	0.011
M	0°	8°	0°	8°
P	10.05	10.55	0.395	0.415
R	0.25	0.75	0.010	0.029

Motorola reserves the right to make changes without further notice to any products herein. Motorola makes no warranty, representation or guarantee regarding the suitability of its products for any particular purpose, nor does Motorola assume any liability arising out of the application or use of any product or circuit, and specifically disclaims any and all liability, including without limitation consequential or incidental damages. "Typical" parameters can and do vary in different applications. All operating parameters, including "Typicals" must be validated for each customer application by customer's technical experts. Motorola does not convey any license under its patent rights nor the rights of others. Motorola products are not designed, intended, or authorized for use as components in systems intended for surgical implant into the body, or other applications intended to support or sustain life, or for any other application in which the failure of the Motorola product could create a situation where personal injury or death may occur. Should Buyer purchase or use Motorola products for any such unintended or unauthorized application, Buyer shall indemnify and hold Motorola and its officers, employees, subsidiaries, affiliates, and distributors harmless against all claims, costs, damages, and expenses, and reasonable attorney fees arising out of, directly or indirectly, any claim of personal injury or death associated with such unintended or unauthorized use, even if such claim alleges that Motorola was negligent regarding the design or manufacture of the part. Motorola and are registered trademarks of Motorola, Inc. Motorola, Inc. is an Equal Opportunity/Affirmative Action Employer.

How to reach us:

USA / EUROPE: Motorola Literature Distribution;
P.O. Box 20912; Phoenix, Arizona 85036. 1-800-441-2447

JAPAN: Nippon Motorola Ltd.; Tatsumi-SPD-JLDC, Toshikatsu Otsuki,
6F Seibu-Butsuryu-Center, 3-14-2 Tatsumi Koto-Ku, Tokyo 135, Japan. 03-3521-8315

MFAX: RMFAX0@email.sps.mot.com - TOUCHTONE (602) 244-6609
INTERNET: http://Design-NET.com

HONG KONG: Motorola Semiconductors H.K. Ltd.; 8B Tai Ping Industrial Park,
51 Ting Kok Road, Tai Po, N.T., Hong Kong. 852-26629298



MC34216A/D

