

Features

- Schottky Barrier Chip
- Ideally Suited for Automatic Assembly
- Low Power Loss, High Efficiency
- For Use in Low Voltage Application
- Guard Ring Die Construction
- Plastic Case Material has UL Flammability Classification Rating 94V-0

Mechanical Data

- Case: TO-220AC, Molded Plastic
- Terminals: Plated Leads Solderable per MIL-STD-202, Method 208
- Polarity: See Diagram
- Mounting Position: Any
- **Lead Free: For RoHS / Lead Free Version**

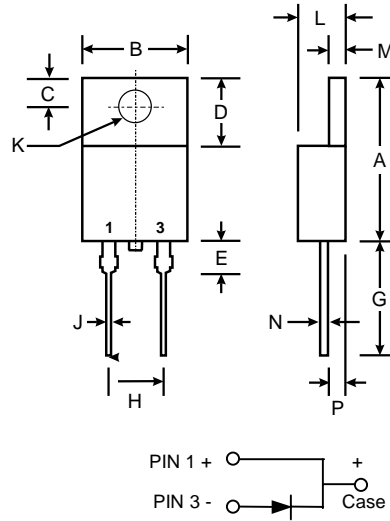

TO-220AC		
Dim	Min	Max
A	14.22	15.88
B	9.57	10.57
C	2.54	3.43
D	5.80	6.80
E	—	6.35
G	12.70	14.73
H	4.88	5.28
J	0.51	1.14
K	3.53 \varnothing	4.14 \varnothing
L	3.56	4.83
M	1.07	1.47
N	0.30	0.64
P	2.03	2.92
All Dimensions in mm		

Maximum Ratings and Electrical Characteristics @ $T_A=25^\circ\text{C}$ unless otherwise specified

Single Phase, half wave, 60Hz, resistive or inductive load.
For capacitive load, derate current by 20%.

Characteristic	Symbol	MBR 640	MBR 645	MBR 650	MBR 660	MBR 680	MBR 6100	MBR 6150	MBR 6200	Units
Peak Repetitive Reverse Voltage	V_{RRM}	40	45	50	60	80	100	150	200	V
Working Peak Reverse Voltage	V_{RWM}									
DC Blocking Voltage	V_R									
RMS Reverse Voltage	$V_{R(RMS)}$	28	31	35	42	56	70	105	140	V
Average Rectified Output Current (Note 1)	I_o	6.0								A
Non-Repetitive Peak Forward Surge Current 8.3ms Single half sine-wave superimposed on rated load (JEDEC Method)	I_{FSM}	100				120				A
Forward Voltage @ $I_F = 6\text{A}$	V_{FM}	0.70		0.80		0.85		0.92		V
Peak Reverse Current At Rated DC Blocking Voltage @ $T_A = 25^\circ\text{C}$ @ $T_A = 100^\circ\text{C}$	I_{RM}	0.1								mA
		20								
Typical Junction Capacitance (Note 2)	C_j	350		280		200				pF
Typical Thermal Resistance (Note 1)	$R_{\theta JA}$	3.5				2.0				$^\circ\text{C/W}$
Operating and Storage Temperature Range	T_j, T_{STG}	-55 to +150						-55 to +175		$^\circ\text{C}$

Note: 1. Valid provided that leads are kept at ambient temperature at a distance of 9.5mm from the case.
2. Measured at 1.0 MHz and applied reverse voltage of 4.0V D.C.

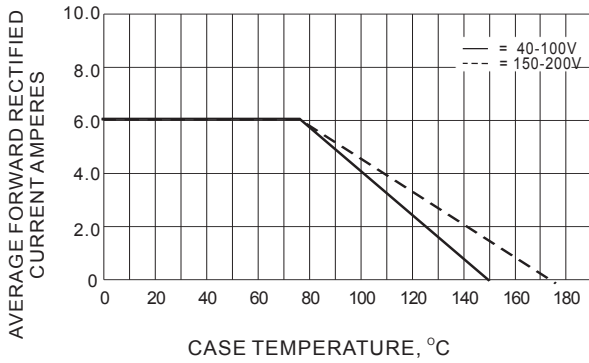

Fig.1- FORWARD CURRENT DERATING CURVE

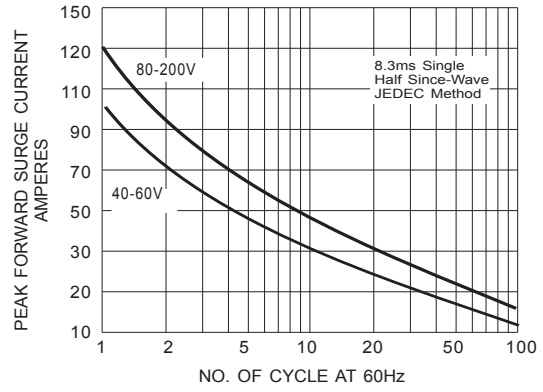

Fig.2- MAXIMUM NON-REPETITIVE SURGE CURRENT

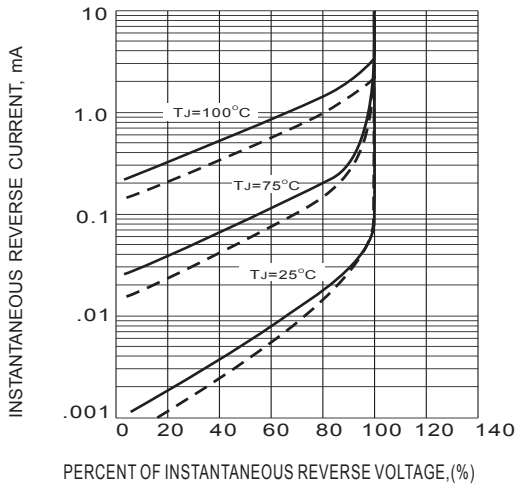

Fig.3- TYPICAL REVERSE CHARACTERISTICS

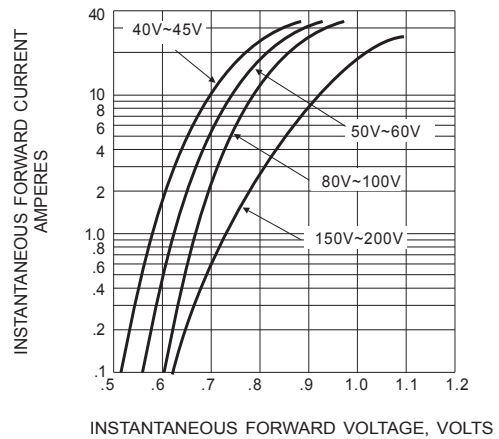

Fig.4- TYPICAL INSTANTANEOUS FORWARD CHARACTERISTICS