



KERSEMI

MBR3020CT~MBR30100CT

SCHOTTKY BARRIER RECTIFIERS

VOLTAGE 20 to 100 Volts **CURRENT** 30.0 Amperes

TO-220AB

Unit : inch (mm)

FEATURES

- Plastic package has Underwriters Laboratory Flammability Classification 94V-O. Flame Retardant Epoxy Molding Compound.
- Exceeds environmental standards of MIL-S-19500/228
- Low power loss, high efficiency.
- Low forward voltage, high current capability
- High surge capacity.
- For use in low voltage, high frequency inverters free wheeling, and polarity protection applications.
- In compliance with EU RoHS 2002/95/EC directives

MECHANICAL DATA

- Case: TO-220AB Molded plastic
- Terminals: Solder plated, solderable per MIL-STD-750, Method 2026
- Polarity: As marked.
- Standard packaging: Any
- Weight: 0.083 ounces, 2.24grams.

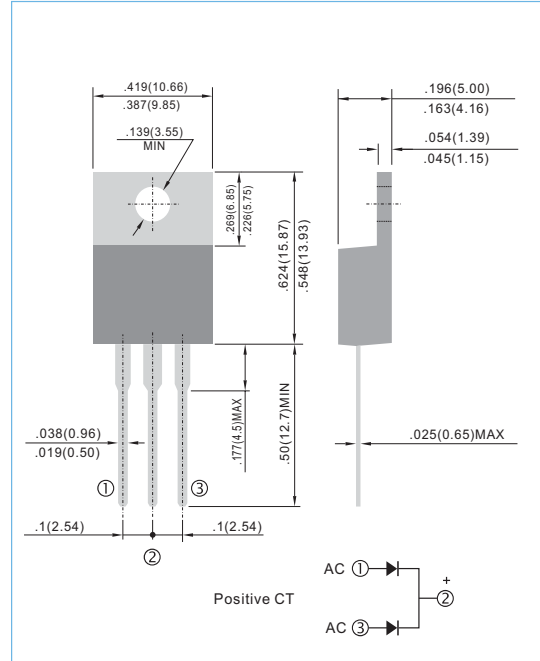

MAXIMUM RATINGS AND ELECTRICAL CHARACTERISTICS

Ratings at 25°C ambient temperature unless otherwise specified. Single phase, half wave, 60 Hz, resistive or inductive load.

For capacitive load, derate current by 20%

PARAMETER	SYMBOL	MBR3020CT	MBR3030CT	MBR3035CT	MBR3040CT	MBR3045CT	MBR3045CT	MBR3050CT	MBR3060CT	MBR3080CT	MBR30100CT	UNITS
Maximum Recurrent Peak Reverse Voltage	V_{RRM}	20	30	35	40	45	45	50	60	80	100	V
Maximum RMS Voltage	V_{RMS}	14	21	24.5	28	31.5	31.5	35	42	56	70	V
Maximum DC Blocking Voltage	V_{DC}	20	30	35	40	45	45	50	60	80	100	V
Maximum Average Forward Current lead length at $T_c=90^\circ\text{C}$	$I_{F(AV)}$	30										A
Peak Forward Surge Current :8.3ms single half sine-wave superimposed on rated load(JEDEC method)	I_{FSM}	275										A
Maximum Forward Voltage at 15A, per leg	V_F	0.55					0.70			0.80		V
Maximum DC Reverse Current $T_j=25^\circ\text{C}$ at Rated DC Blocking Voltage $T_j=100^\circ\text{C}$	I_R	0.1					20					mA
Typical Thermal Resistance	$R_{\theta JC}$	1.5										$^\circ\text{C} / \text{W}$
Operating Junction and Storage Temperature Range	T_j, T_{STG}	-50 TO + 150										$^\circ\text{C}$

www.kersemi.com

MBR3020CT~MBR30100CT



KERSEMI

RATING AND CHARACTERISTIC CURVES

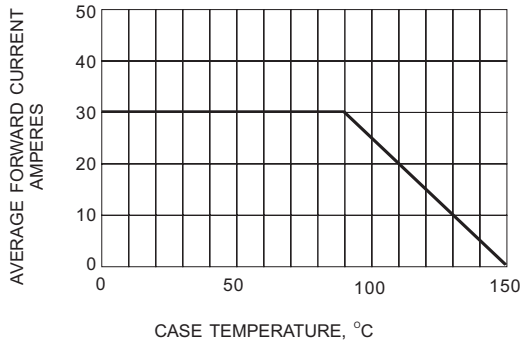

Fig.1- FORWARD CURRENT DERATING CURVE

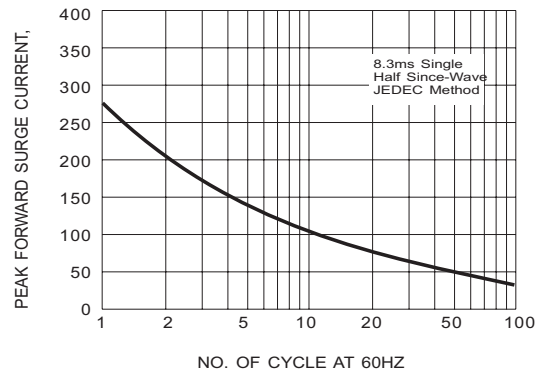

Fig.2- MAXIMUM NON - REPETITIVE SURGE CURRENT

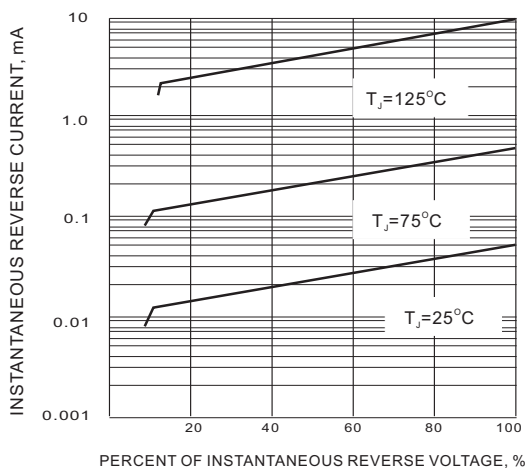

Fig.3- TYPICAL REVERSE CHARACTERISTICS

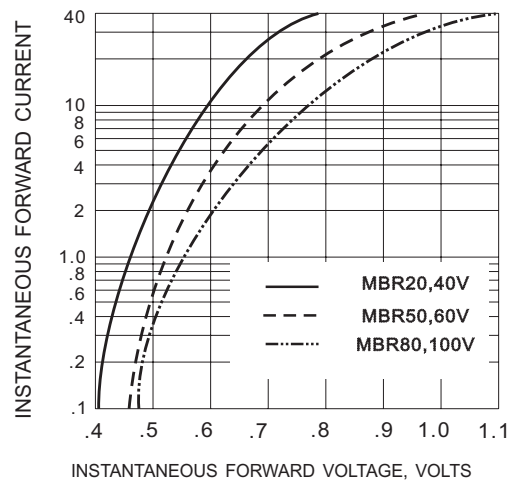

Fig.4- TYPICAL INSTANTANEOUS FORWARD CHARACTERISTICS

LEGAL STATEMENT

www.kersemi.com