

Surface Mount Schottky Barrier Rectifier

Reverse Voltage - 40 to 200 V

Forward Current - 20 A



FEATURES

- ◆ High current capability
- ◆ Low forward voltage drop
- ◆ High surge capability
- ◆ High temperature soldering guaranteed
- ◆ Mounting position: any
- ◆ Lead free in comply with EU RoHS 2011/65/EU directives

MECHANICAL DATA

- ◆ Case: TO-252(D-PAK)
- ◆ Terminals: Solderable per MIL-STD-750, Method 2026
- ◆ Approx. Weight: 0.32g / 0.011oz

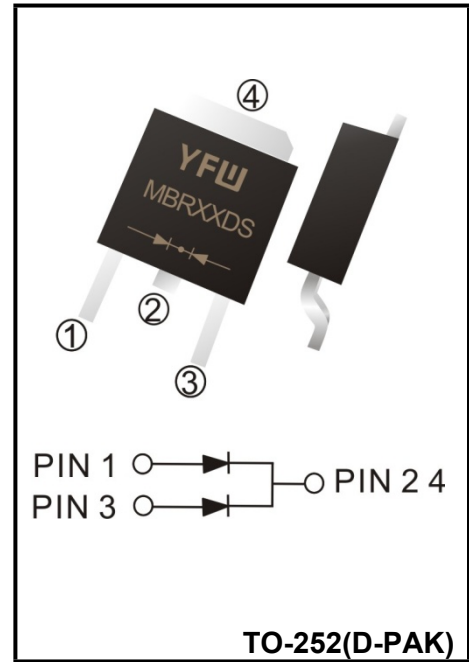

Maximum Ratings and Electrical characteristics
Ratings at 25 ° ambient temperature unless otherwise specified.

Parameter	Symbols	MBR2040DS	MBR2045DS	MBR2060DS	MBR20100DS	MBR20150DS	MBR20200DS	Units	
Maximum Repetitive Peak Reverse Voltage	V_{RRM}	40	45	60	100	150	200	V	
Maximum RMS voltage	V_{RMS}	28	31.5	42	70	105	140	V	
Maximum DC Blocking Voltage	V_{DC}	40	45	60	100	150	200	V	
Maximum Average Forward Rectified Current	$I_{F(AV)}$	20						A	
Peak Forward Surge Current, 8.3ms Single Half Sine-wave Superimposed On Rated Load (JEDEC method)	I_{FSM}	150						A	
Maximum Instantaneous Forward Voltage at 10 A	V_F	0.70		0.75	0.85	0.90	0.92	v	
Maximum Instantaneous Reverse Current at Rated DC Reverse Voltage <small>$T_A = 25^{\circ}C$ $T_A = 100^{\circ}C$</small>	I_R	0.1 20			0.05 20			mA	
Typical Junction Capacitance ⁽¹⁾	C_j	600	400					pF	
Typical Thermal Resistance ⁽²⁾	$R_{\theta JA}$	45						°C/W	
Operating Junction Temperature Range	T_j	-55 ~ +150				-55 ~ +175			°C
Storage Temperature Range	T_{stg}	-55 ~ +150				-55 ~ +175			°C

(1) Measured at 1 MHz and applied reverse voltage of 4 V D.C
(2) P.C.B. mounted with 10cm X 10cmX1mm copper pad areas.

Fig.1 TYPICAL FORWARD CURRENT DERATING CURVE

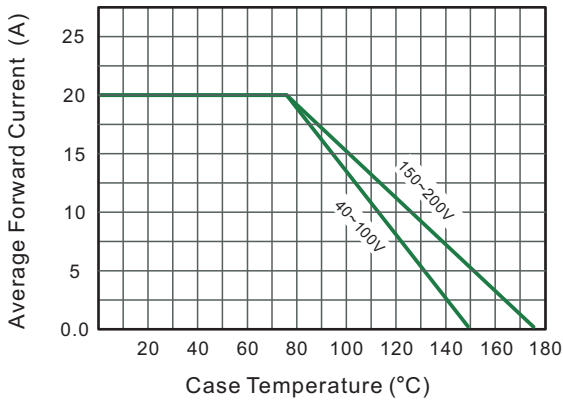

Fig.2 Typical Reverse Characteristics

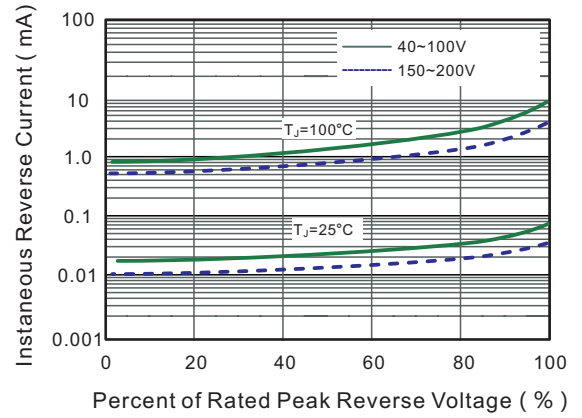

Fig.3 Typical Forward Characteristic

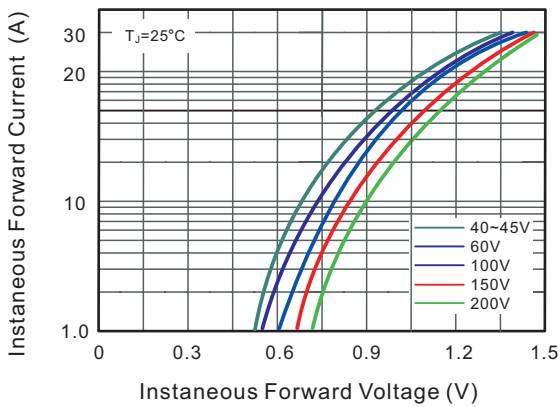

Fig.4 Typical Junction Capacitance

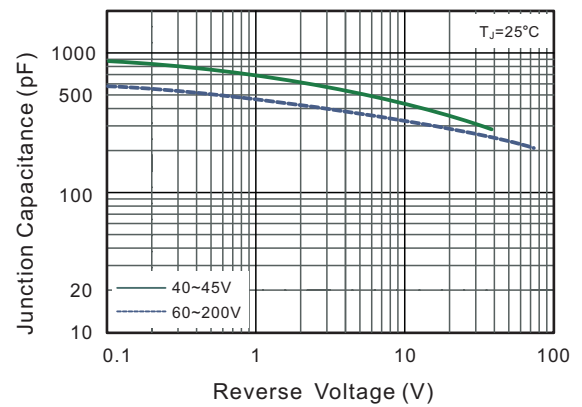

Fig.5 Maximum Non-Repetitive Peak Forward Surge Current

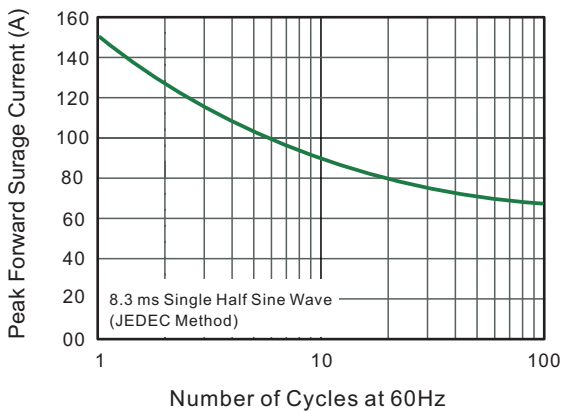
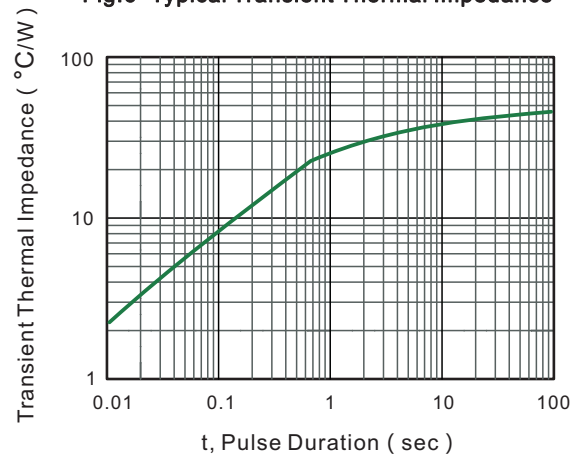
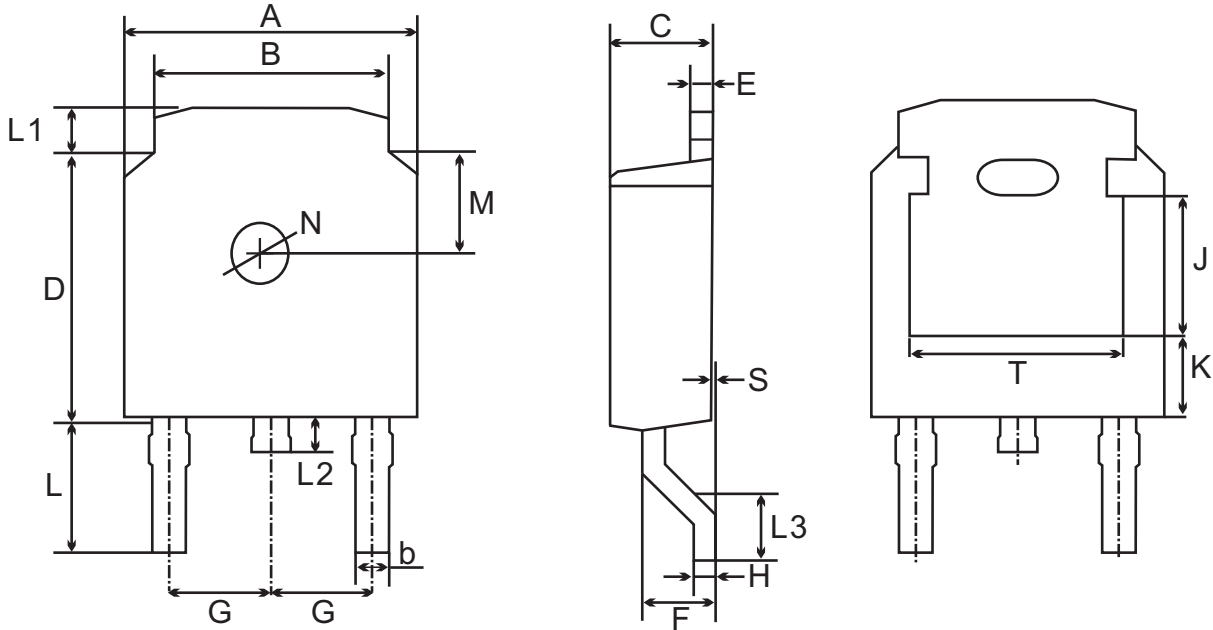

Fig.6- Typical Transient Thermal Impedance



Package Outline

TO-252(D-PAK)



UNIT		A	B	b	C	D	E	F	G	H	L	L1	L2	L3	S	M	N	J	K	T
mm	max	6.7	5.5	0.8	2.5	6.3	0.6	1.8	2.29 TYPICAL	0.55	3.1	1.2	1.0	1.75	0.1	1.8 TYPICAL	1.3 TYPICAL	3.16	1.80	4.83
	min	6.3	5.1	0.3	2.1	5.9	0.4	1.3		0.45	2.7	0.8	0.6	1.40	0.0			ref.	ref.	ref.
mil	max	264	217	31	98	248	24	71	90 TYPICAL	22	122	47	39	69	4	71 TYPICAL	51 TYPICAL	124	71	190
	min	248	201	12	83	232	16	51		18	106	31	24	55	0			ref.	ref.	ref.

Marking on the body

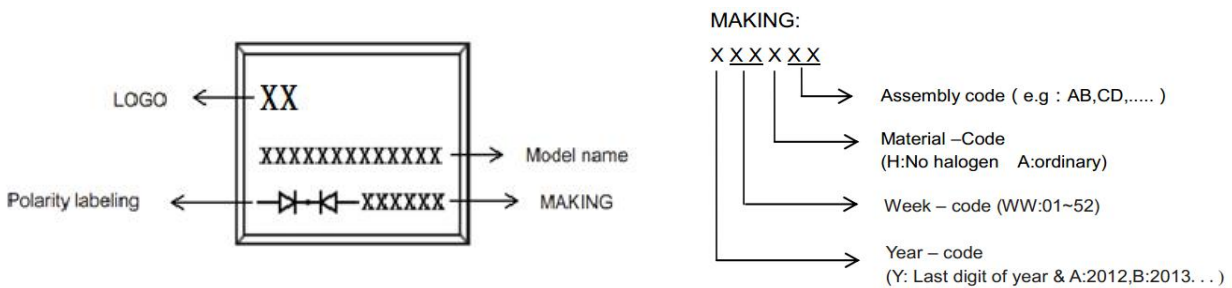

Summary of Packing Options

Package	Packing Description	Packing Quantity	Industry Standard
TO-252(D-PAK)	Tape/Reel,13"reel	2500	EIA-481-1