

# ASSP

## Bidirectional Motor Driver

### MB3763

#### ■ DESCRIPTION

Fujitsu's MB3763 Motor Driver with forward/reverse control capability, is used in applications such as the front-loading mechanism in video tape, or the auto-reverse tape deck, driven by a TTL signal. The MB3763 has 150 mA drive units and braking capability with TTL control.

#### ■ FEATURES

- Motor Drive Current: 150 mA maximum (DC)  
300 mA maximum ( $t_{ON} = 1$  s, Duty = 50 %)
- Wide Power Supply Voltage Range: 4V to 18V
- TTL-control capability
- Standby capability when input is off.
- Brake capability at motor stop mode.
- Built-in diode for surge absorption
- Package: 8-pin plastic DIP package (Suffix: -P)  
8-pin plastic SOP package (Suffix: -PF)

#### ■ PACKAGE

8-pin plastic DIP

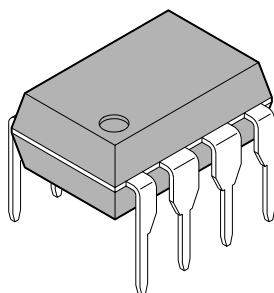

(DIP-8P-M01)

8-pin plastic SOP

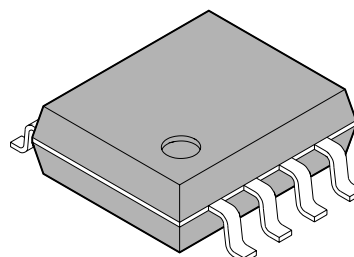

(FPT-8P-M01)

# MB3763

## ■ PIN ASSIGNMENT

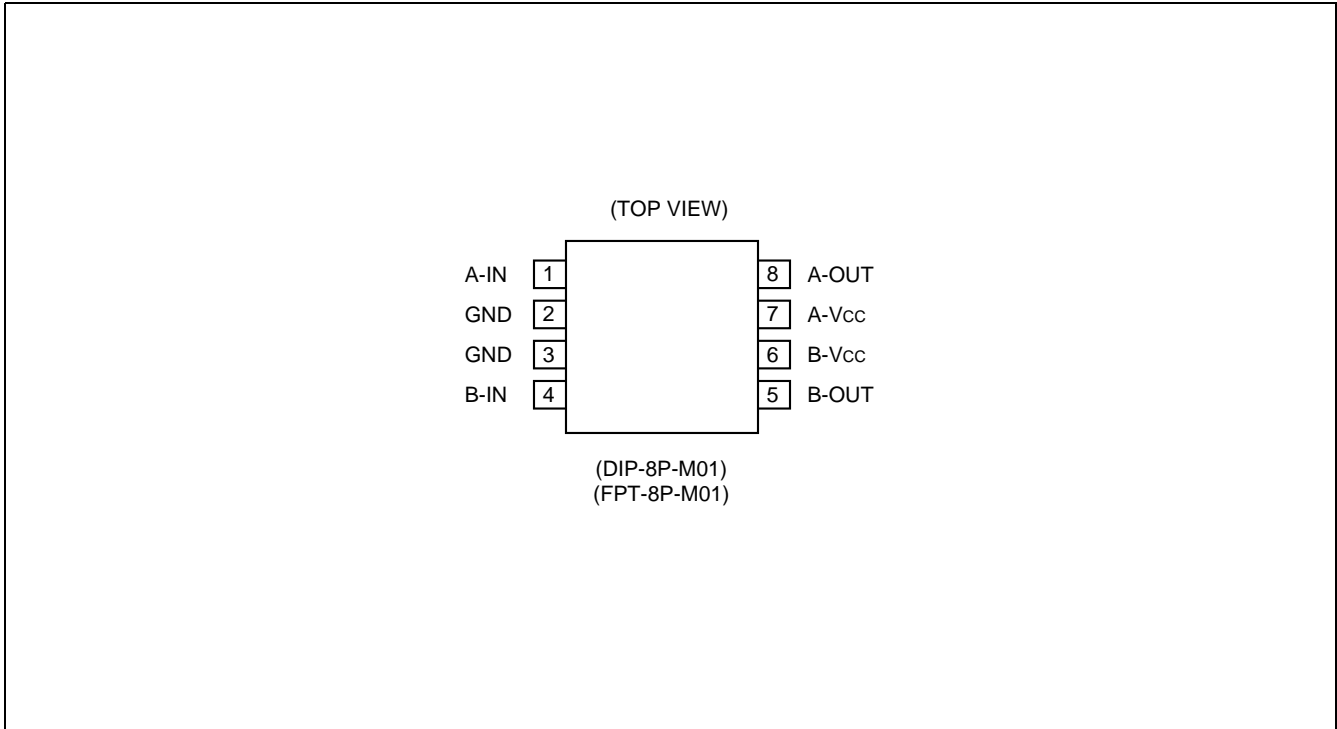

## ■ BLOCK DIAGRAM

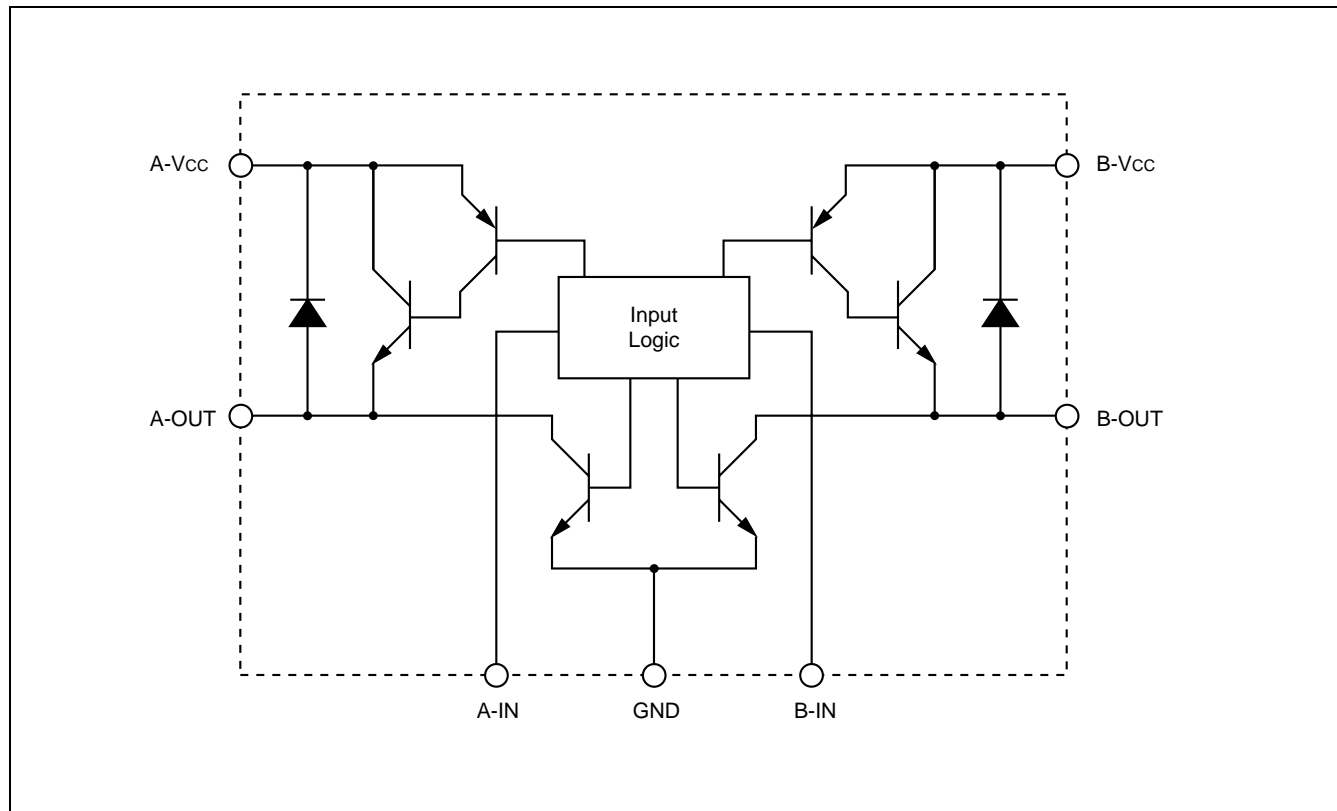

## ■ ABSOLUTE MAXIMUM RATINGS

(Ta = +25°C)

Parameter	Symbol	Rating		Unit
		Min.	Max.	
Power supply voltage	V <sub>CC</sub>	—	20	V
Output current	I <sub>O</sub>	—	180 (330* <sup>1</sup> )	mA
Maximum output current	I <sub>OMAX</sub> * <sup>3</sup>	—	1.2	A
Power Dissipation	P <sub>D</sub>	—	560* <sup>2</sup>	mW
Operating temperature	T <sub>C</sub>	-20	+75	°C
Storage temperature	T <sub>stg</sub>	-55	+125	°C

\*1: t<sub>ON</sub> ≤ 1 s, Duty = 50%

\*2: Ta ≤ 60°C

\*3: t ≤ 5 ms

**WARNING:** Semiconductor devices can be permanently damaged by application of stress (voltage, current, temperature, etc.) in excess of absolute maximum ratings. Do not exceed these ratings.

## ■ RECOMMENDED OPERATING CONDITIONS

Parameter	Symbol	Value		Unit
		Min.	Max.	
Power supply voltage	V <sub>CC</sub>	4	18	V
Output current	I <sub>O</sub>	0	150 (300* <sup>1</sup> )	mA
Input high voltage	V <sub>IH</sub> * <sup>2</sup>	2.4	V <sub>CC</sub> + 0.3	V
Input low voltage	V <sub>IL</sub>	0	0.4	V

\*1: t<sub>ON</sub> ≤ 1 s, Duty = 50%

\*2: When V<sub>IH</sub> ≥ V<sub>CC</sub>, I<sub>IH</sub> ≤ V<sub>CC</sub> × 0.2 mA

**WARNING:** The recommended operating conditions are required in order to ensure the normal operation of the semiconductor device. All of the device's electrical characteristics are warranted when the device is operated within these ranges.

Always use semiconductor devices within their recommended operating condition ranges. Operation outside these ranges may adversely affect reliability and could result in device failure.

No warranty is made with respect to uses, operating conditions, or combinations not represented on the data sheet. Users considering application outside the listed conditions are advised to contact their FUJITSU representatives beforehand.

# MB3763

## ■ ELECTRICAL CHARACTERISTICS

( $V_{CC} = 12\text{ V}$ ,  $T_a = +25^\circ\text{C}$ )

Parameter	Symbol	Condition	Value			Unit
			Min.	Typ.	Max.	
Standby supply current	$I_{CC0}$	$V_{CC} = 18\text{ V}$ , $V_{IA} = V_{IB} = 0\text{ V}$	—	—	1.0	mA
Power supply current	$I_{CC1}$	$I_o = 0\text{ mA}$	—	10	20	mA
	$I_{CC2}$	$I_o = 150\text{ mA}$	—	10	—	mA
		$I_o = 300\text{ mA}$	—	15	—	mA
	$I_{CC3}$	$I_o = 0\text{ mA}$ , $V_{IA} = V_{IB} = 2.4\text{ V}$	—	15	—	mA
Output high voltage	$V_{OH}$	$I_o = 150\text{ mA}$	11.0	11.2	—	V
		$I_o = 300\text{ mA}$	10.8	11.1	—	V
Output low voltage	$V_{OL}$	$I_o = 150\text{ mA}$	—	0.1	0.2	V
		$I_o = 300\text{ mA}$	—	0.2	0.5	V
Output saturation voltage	$V_{SAT}$	$I_o = 150\text{ mA}$	—	0.9	1.2	V
		$I_o = 300\text{ mA}$	—	1.1	1.7	V
Input current	$I_{IH}$	$V_{IN} = 2.4\text{ V}$	—	250	400	$\mu\text{A}$
Input switching prohibition time	$T_{OFF}$	—	10	—	—	$\mu\text{s}$

## FUNCTIONAL DESCRIPTIONS

### FORWARD/REVERSE MODE (MODE B & C)

In this mode, the transistor pairs Q2-Q3 and Q1-Q4 work alternatively, changing the output current direction. When the mode B is selected, Q2 and Q3 are active and Q1 and Q4 are inactive. Therefore A-OUT is at low level and B-OUT is at high level, with the current flowing from B-OUT to A-OUT through the motor. On the other hand, when the mode C is selected, the current flows in the reverse direction.

### BRAKE/STOP MODE (MODE A)

When the mode A is selected, Q1 and Q3 are inactive and Q2 and Q4 are active. A-OUT and B-OUT are stuck at low-level; terminals of motor are shorted and the motor is forced to stop.

### STANDBY MODE (MODE D)

In this mode, all transistors are inactive and the current through the motor does not flow. When the power supply voltage is applied to A-Vcc and B-Vcc, the supply current is still less than or equal to 1 mA.

## CONTROL MODE

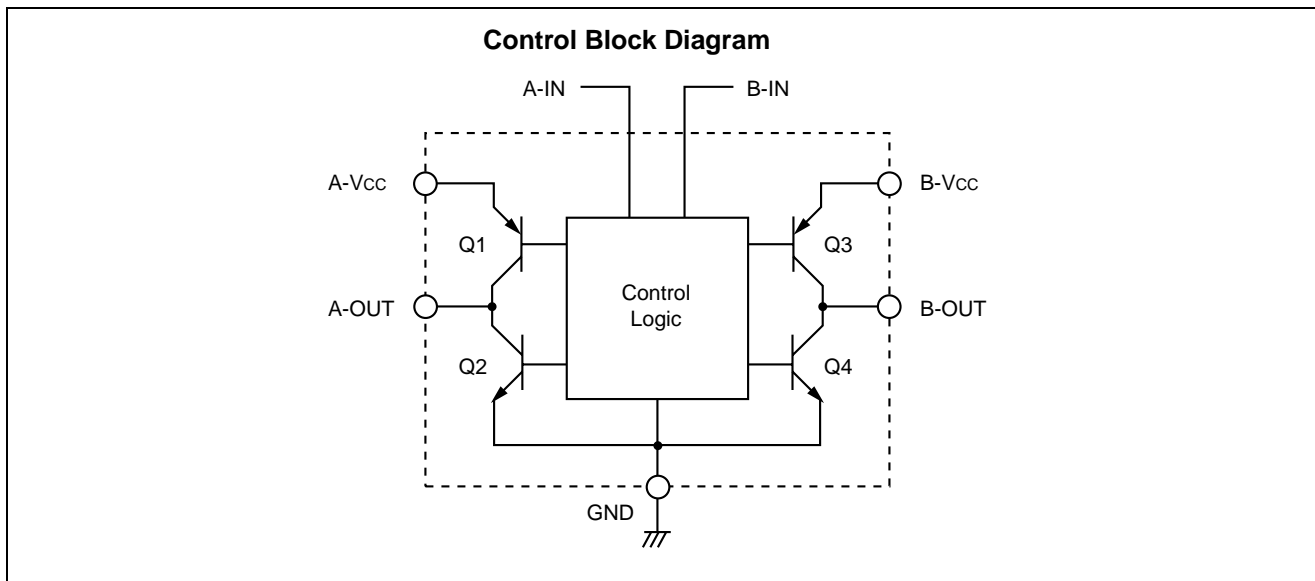

Mode	Input mode		Output mode		Operation
	A-IN	B-IN	A-OUT	B-OUT	
A	1	1	L	L	short (Brake)
B	1	0	L	H	Forward
C	0	1	H	L	Reverse
D	0	0	—	—	Open (Standby)

Notes: 1:  $\geq 2.4V$   
0:  $\leq 0.4V$

## ■ TYPICAL APPLICATION

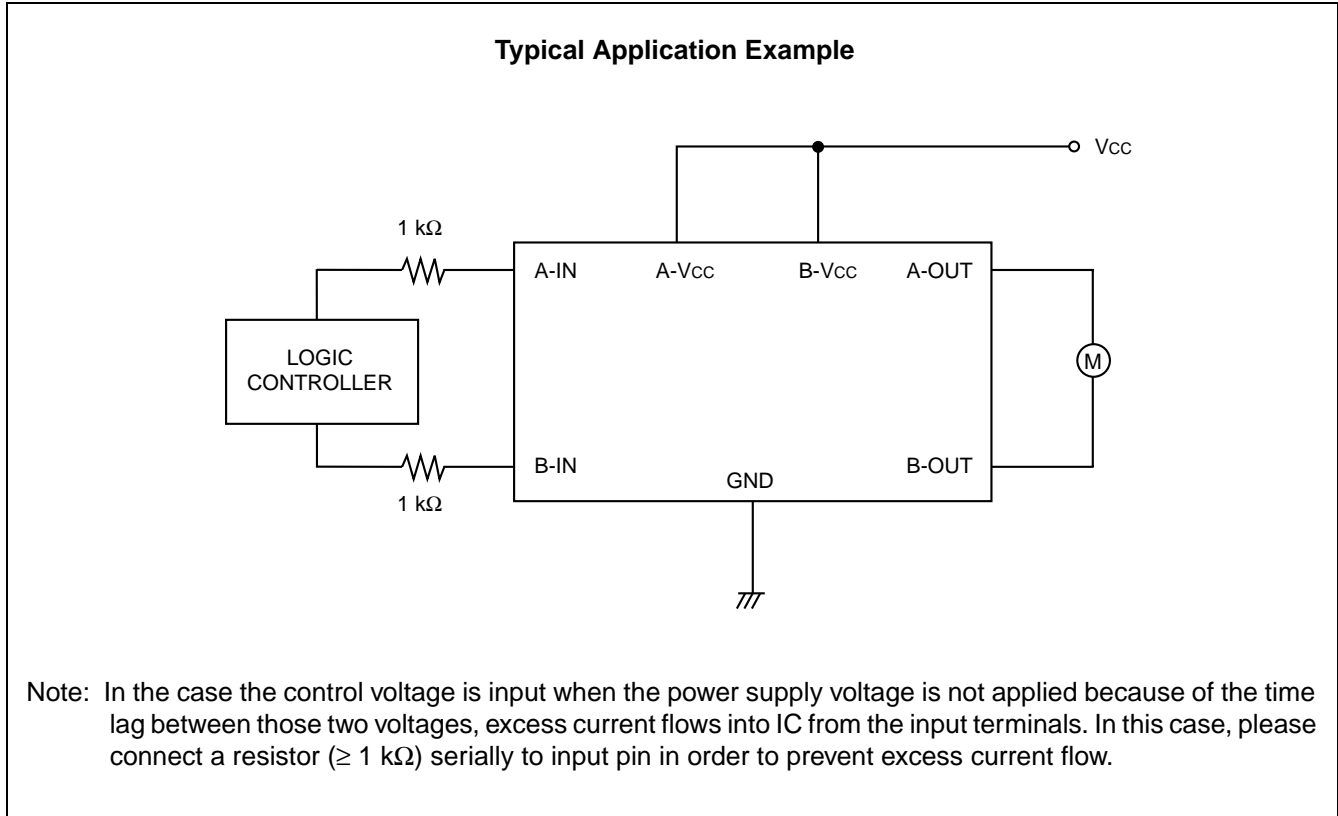

## ■ TYPICAL PERFORMANCE CHARACTERISTICS

**Output Current vs. Power Supply Current**

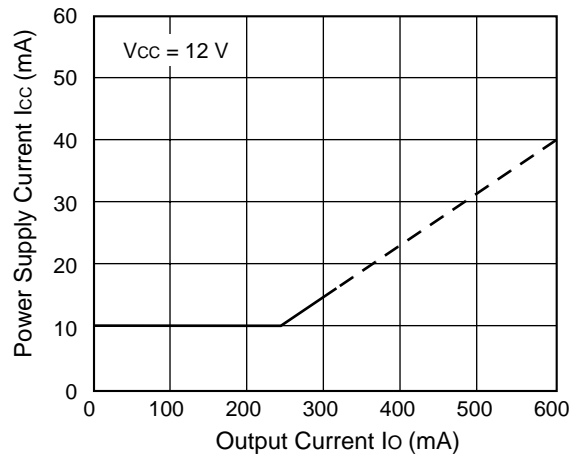

**Power Supply Voltage vs. Power Supply Current**

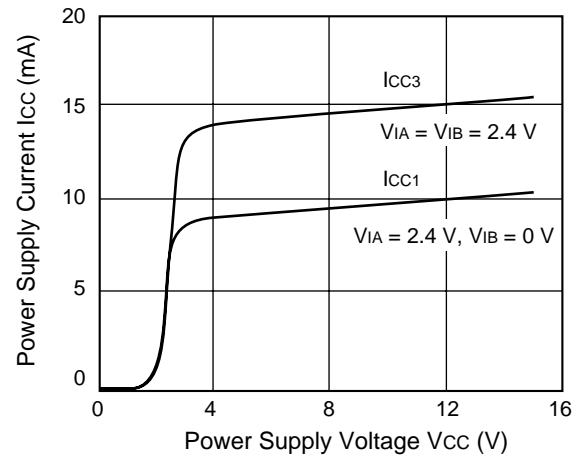

**Output Current vs. Output Voltage**

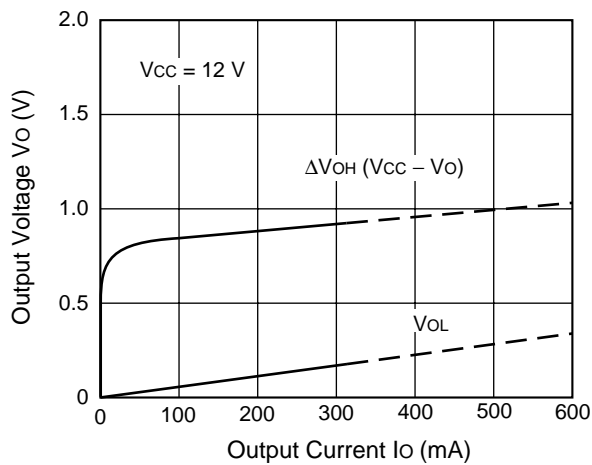

**Input Voltage vs. Input Current**

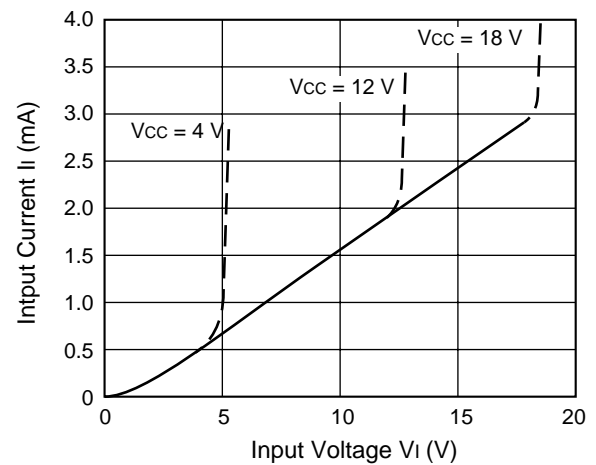

(Continued)

# MB3763

(Continued)

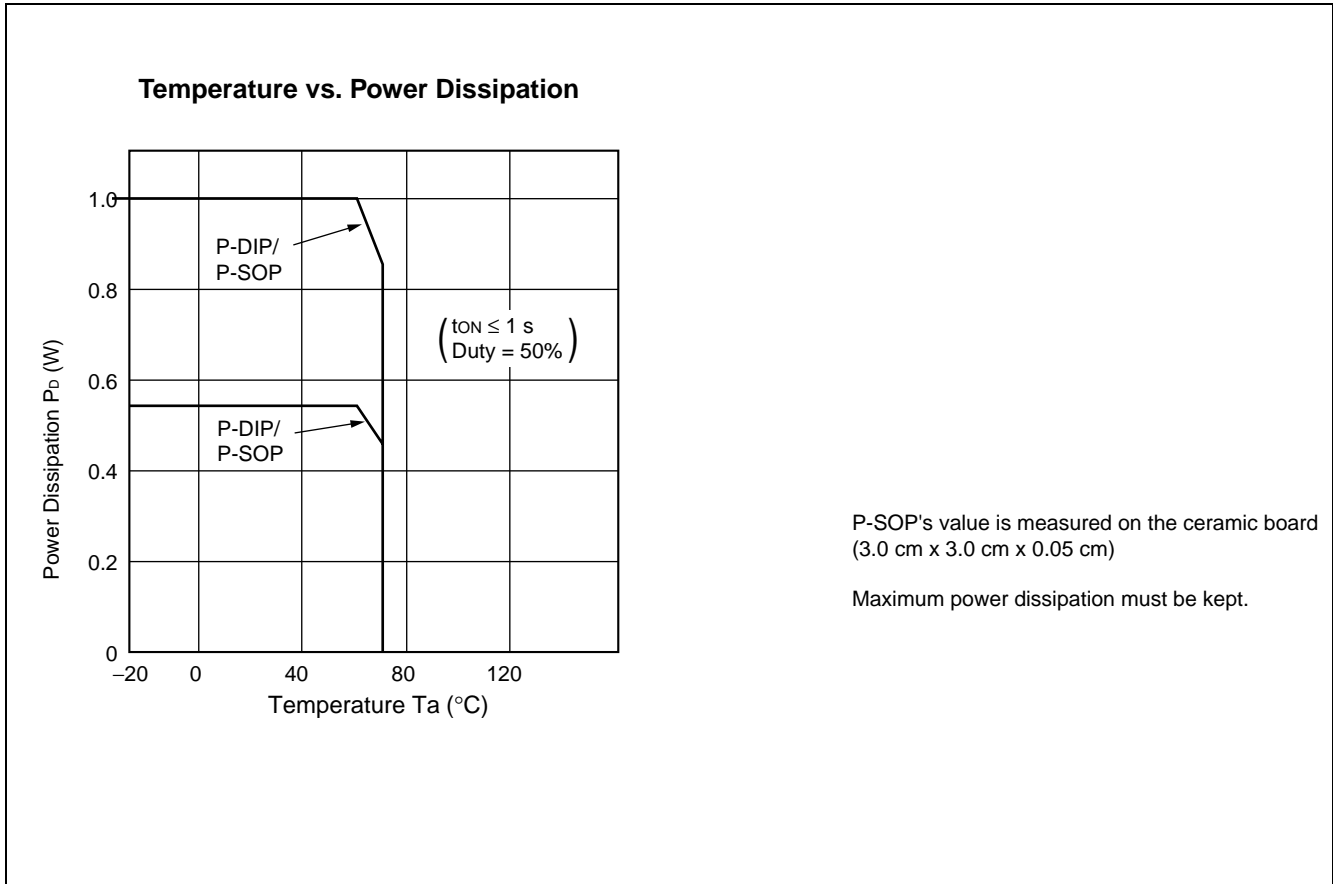

## ■ ORDERING INFORMATION

Part number	Package	Remarks
MB3763	8-pin plastic DIP (DIP-8P-M01)	
MB3763PF	8-pin plastic SOP (FPT-8P-M01)	



## ■ PACKAGE DIMENSIONS

8-pin plastic DIP  
(DIP-8P-M01)

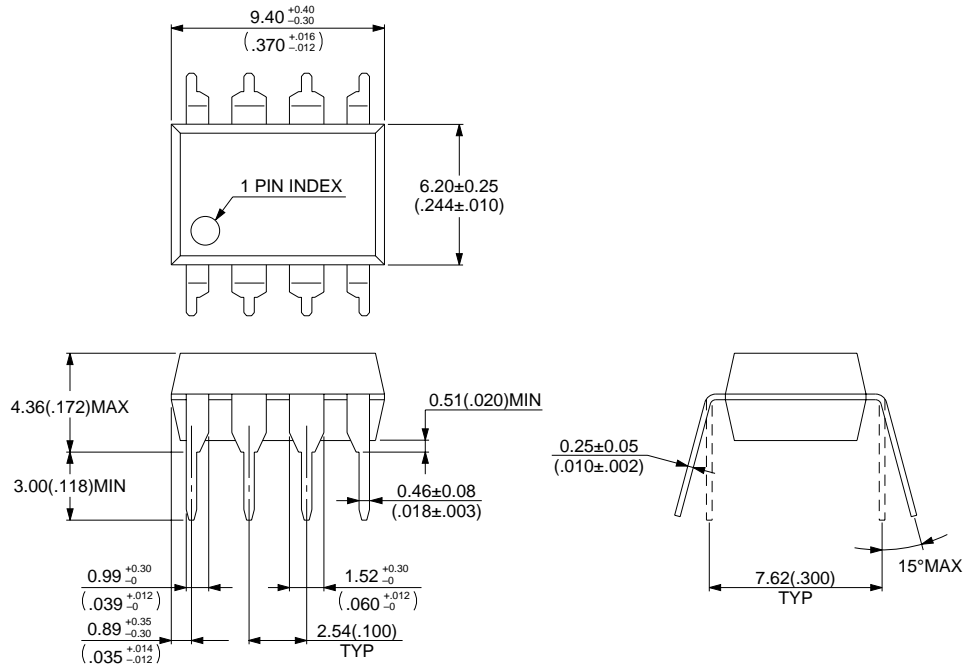

Dimensions in mm (inches)

© 1994 FUJITSU LIMITED D08006S-2C-3

(Continued)

# MB3763

(Continued)

8-pin plastic SOP  
(FPT-8P-M01)

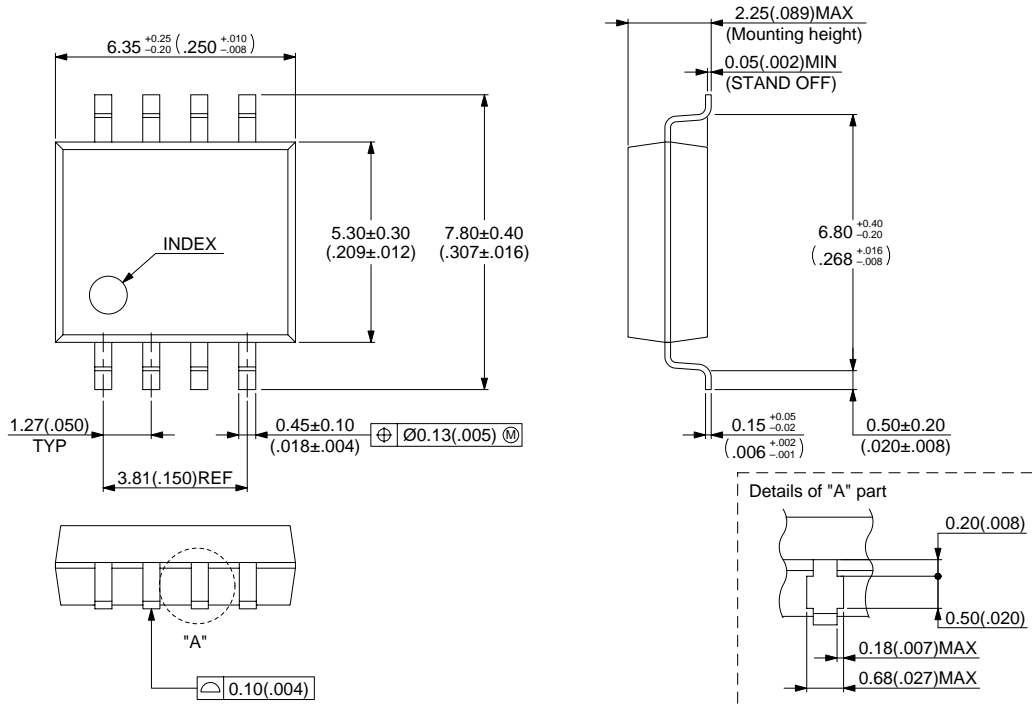

Dimensions in mm (inches)

© 2000 FUJITSU LIMITED F08002S-4C-5

## FUJITSU LIMITED

*For further information please contact:*

### **Japan**

FUJITSU LIMITED  
Corporate Global Business Support Division  
Electronic Devices  
Shinjuku Dai-Ichi Seimei Bldg. 7-1,  
Nishishinjuku 2-chome, Shinjuku-ku,  
Tokyo 163-0721, Japan  
Tel: +81-3-5322-3347  
Fax: +81-3-5322-3386

<http://edevice.fujitsu.com/>

### **North and South America**

FUJITSU MICROELECTRONICS, INC.  
3545 North First Street,  
San Jose, CA 95134-1804, U.S.A.  
Tel: +1-408-922-9000  
Fax: +1-408-922-9179

Customer Response Center  
*Mon. - Fri.: 7 am - 5 pm (PST)*  
Tel: +1-800-866-8608  
Fax: +1-408-922-9179

<http://www.fujitsumicro.com/>

### **Europe**

FUJITSU MICROELECTRONICS EUROPE GmbH  
Am Siebenstein 6-10,  
D-63303 Dreieich-Buchsschlag,  
Germany  
Tel: +49-6103-690-0  
Fax: +49-6103-690-122

<http://www.fujitsu-fme.com/>

### **Asia Pacific**

FUJITSU MICROELECTRONICS ASIA PTE. LTD.  
#05-08, 151 Lorong Chuan,  
New Tech Park,  
Singapore 556741  
Tel: +65-281-0770  
Fax: +65-281-0220

<http://www.fmap.com.sg/>

### **Korea**

FUJITSU MICROELECTRONICS KOREA LTD.  
1702 KOSMO TOWER, 1002 Daechi-Dong,  
Kangnam-Gu, Seoul 135-280  
Korea  
Tel: +82-2-3484-7100  
Fax: +82-2-3484-7111

F0101

© FUJITSU LIMITED Printed in Japan

All Rights Reserved.

The contents of this document are subject to change without notice. Customers are advised to consult with FUJITSU sales representatives before ordering.

The information and circuit diagrams in this document are presented as examples of semiconductor device applications, and are not intended to be incorporated in devices for actual use. Also, FUJITSU is unable to assume responsibility for infringement of any patent rights or other rights of third parties arising from the use of this information or circuit diagrams.

The contents of this document may not be reproduced or copied without the permission of FUJITSU LIMITED.

FUJITSU semiconductor devices are intended for use in standard applications (computers, office automation and other office equipments, industrial, communications, and measurement equipments, personal or household devices, etc.).

#### **CAUTION:**

Customers considering the use of our products in special applications where failure or abnormal operation may directly affect human lives or cause physical injury or property damage, or where extremely high levels of reliability are demanded (such as aerospace systems, atomic energy controls, sea floor repeaters, vehicle operating controls, medical devices for life support, etc.) are requested to consult with FUJITSU sales representatives before such use. The company will not be responsible for damages arising from such use without prior approval.

Any semiconductor devices have inherently a certain rate of failure. You must protect against injury, damage or loss from such failures by incorporating safety design measures into your facility and equipment such as redundancy, fire protection, and prevention of over-current levels and other abnormal operating conditions.

If any products described in this document represent goods or technologies subject to certain restrictions on export under the Foreign Exchange and Foreign Trade Control Law of Japan, the prior authorization by Japanese government should be required for export of those products from Japan.