

EVALUATION KIT
AVAILABLE**MAXIM**

Complete Backup-Management ICs for Lithium and NiMH Batteries

General Description

The MAX8568A/MAX8568B backup-battery-management ICs are complete charging and backup switchover control solutions for PDAs, Smart Phones, and other smart portable devices. They charge both NiMH and rechargeable lithium battery types and feature programmable charge current and termination voltage. Separate optimized charge algorithms for both lithium and NiMH cells are included on-chip.

The MAX8568A/MAX8568B also manage backup switchover from a primary power source. An accurate on-chip voltage detector monitors the main supply and backs up two system supplies (typically I/O and memory) when main power falls. On-chip drivers switch external MOSFETs to disconnect the main supply from the system loads so the backup source is not drained.

Low-voltage backup cells can be stepped up by an on-chip synchronous-rectified, low-quiescent-current boost converter. Additionally, a low-quiescent-current LDO generates a second backup voltage. The MAX8568A LDO is preset to 2.5V while the MAX8568B LDO is preset to 1.8V. Both devices are supplied in 16-pin 3mm x 3mm thin QFN packages rated for -40°C to +85°C operation.

Applications

PDAs and PDA Phones
Smart Phones
DSCs and DVCs
Palmtops and Wireless Handhelds
Internet Appliances and Web-Books

Pin Configuration

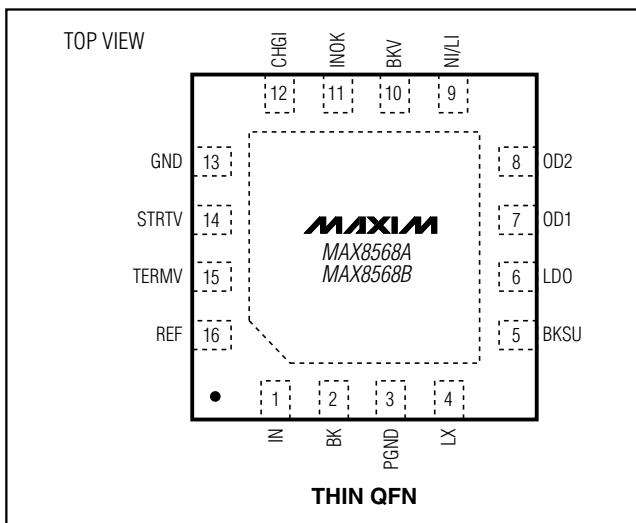

Features

- ◆ Automatically Manage All Backup Switchover Functions
- ◆ Charge Both NiMH and Rechargeable Lithium Backup Batteries
- ◆ On-Chip Battery Boost Converter for 1-Cell NiMH
- ◆ Two Backup Output Voltages
- ◆ Programmable Charge Current
- ◆ Programmable Charge Voltage Limit
- ◆ Low 17 μ A Operating Current in Backup Mode
- ◆ Eliminate Many Discrete Components
- ◆ Tiny 3mm x 3mm Thin QFN Package

Ordering Information

PART	TEMP RANGE	PIN-PACKAGE	TOP MARK
MAX8568AETE	-40°C to +85°C	16 Thin QFN 3mm x 3mm (T1633-4)	ACK
MAX8568BETE	-40°C to +85°C	16 Thin QFN 3mm x 3mm (T1633-4)	ACL

Typical Operating Circuit

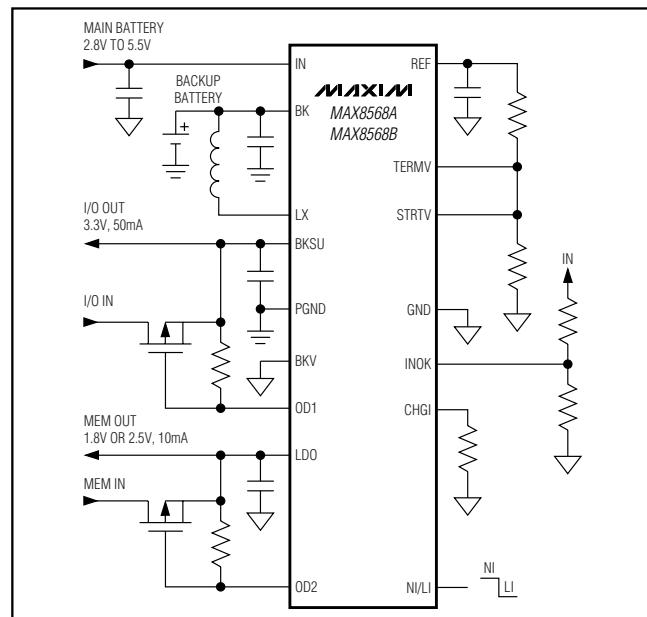

MAX8568A/MAX8568B

MAXIM

Maxim Integrated Products 1

For pricing, delivery, and ordering information, please contact Maxim/Dallas Direct! at 1-888-629-4642, or visit Maxim's website at www.maxim-ic.com.

Complete Backup-Management ICs for Lithium and NiMH Batteries

ABSOLUTE MAXIMUM RATINGS

IN, BK, BKSU, OD1, OD2 to GND.....-0.3V to +6.0V
 BKV, LDO, NI/LI to GND.....-0.3V to ($V_{BKSU} + 0.3V$)
 REF, CHGI, INOK, TERMV, STRTV to GND...-0.3V to ($V_{IN} + 0.3V$)
 PGND to GND-0.3V to + 0.3V
 LX Current0.9A_{RMS}

Continuous Power Dissipation ($T_A = +70^\circ\text{C}$)
 16-Pin 3mm x 3mm Thin QFN
 (derate 15.6mW/ $^\circ\text{C}$ above $+70^\circ\text{C}$).....1250mW
 Operating Temperature Range-40 $^\circ\text{C}$ to +85 $^\circ\text{C}$
 Junction Temperature+150 $^\circ\text{C}$
 Storage Temperature Range.....-65 $^\circ\text{C}$ to +150 $^\circ\text{C}$
 Lead Temperature (soldering, 10s).....+300 $^\circ\text{C}$

Stresses beyond those listed under "Absolute Maximum Ratings" may cause permanent damage to the device. These are stress ratings only, and functional operation of the device at these or any other conditions beyond those indicated in the operational sections of the specifications is not implied. Exposure to absolute maximum rating conditions for extended periods may affect device reliability.

ELECTRICAL CHARACTERISTICS

(Circuit of Figure 7, $V_{IN} = V_{INOK} = 3.6V$, $V_{BK} = 1.4V$, $V_{NI/LI} = V_{BKSU} = 3.3V$, $V_{BKV} = \text{GND} = \text{PGND} = 0V$, $V_{STRTV} = V_{TERMV} = 1.2V$, $R_5 = 250k\Omega$, $T_A = 0^\circ\text{C}$ to $+85^\circ\text{C}$, unless otherwise noted. Typical values are at $T_A = +25^\circ\text{C}$.) (Note 1)

PARAMETER	CONDITIONS	MIN	TYP	MAX	UNITS
IN Voltage Range		2.8		5.5	V
IN Operating Current	Charger off, $V_{INOK} = 1.5V$	$T_A = +25^\circ\text{C}$	3	5	μA
		$T_A = +85^\circ\text{C}$	3		
	Charger on, not including charge current		50	90	
CHGI Current Limit	$R_{CHGI} = 169k\Omega$, $V_{BK} = 1.3V$	8	10	12	mA
CHGI Bias Voltage			600		mV
CHGI Resistor Range	$V_{BK} = 1.3V$	50		1800	k Ω
BK Charge Voltage Limit	$V_{IN} = 5.5V$, $V_{NI/LI} = 0V$	4.116	4.2	4.284	V
	$V_{IN} = 3.8V$, $V_{NI/LI} = 0V$, $V_{TERMV} = 1V$	3.42	3.5	3.58	
	$V_{IN} = V_{NI/LI} = 3.6V$	1.746	1.8	1.854	
BK Reverse Leakage Current to IN	$V_{IN} = 0V$	$T_A = +25^\circ\text{C}$	0.01	0.5	μA
		$T_A = +85^\circ\text{C}$	0.1		
NiMH Mode BK High Threshold Voltage, $V_{BK(NIHI)}$	$V_{TERMV} = 1.2V$	1.37	1.4	1.43	V
NiMH Mode BK Low Threshold Voltage, $V_{BK(NILO)}$	$V_{STRTV} = 1.2V$	1.17	1.2	1.23	V
TERMV Input Current	$V_{TERMV} = 1.1V$	$T_A = +25^\circ\text{C}$	0.001	0.05	μA
		$T_A = +85^\circ\text{C}$	0.01		
STRTV Input Current	$V_{STRTV} = 1.1V$	$T_A = +25^\circ\text{C}$	0.001	0.05	μA
		$T_A = +85^\circ\text{C}$	0.01		
REF Output Voltage	$I_{REF} = 1\mu\text{A}$	1.23	1.25	1.27	V
REF Load Regulation	$I_{REF} = 1\mu\text{A}$ to $50\mu\text{A}$		2.5	10	mV
REF Line Regulation	$V_{IN} = 3V$ to $5.5V$, $I_{REF} = 1\mu\text{A}$		1	7	mV
INOK Threshold Voltage	V_{INOK} falling	2.38	2.43	2.48	V
	V_{INOK} rising	2.40	2.47	2.54	
INOK Input Current	$V_{INOK} = 2V$	$T_A = +25^\circ\text{C}$	0.005	0.1	μA
		$T_A = +85^\circ\text{C}$	0.05		
NI/LI Logic-Level High	$V_{BKSU} = 3.3V$	1.8			V
NI/LI Logic-Level Low	$V_{BKSU} = 3.3V$			0.4	V

Complete Backup-Management ICs for Lithium and NiMH Batteries

MAX8568A/MAX8568B

ELECTRICAL CHARACTERISTICS (continued)

(Circuit of Figure 7, $V_{IN} = V_{INOK} = 3.6V$, $V_{BK} = 1.4V$, $V_{NI/LI} = V_{BKSU} = 3.3V$, $V_{BKV} = GND = PGND = 0V$, $V_{STRTV} = V_{TERMV} = 1.2V$, $R5 = 250k\Omega$, $T_A = 0^\circ C$ to $+85^\circ C$, unless otherwise noted. Typical values are at $T_A = +25^\circ C$.) (Note 1)

PARAMETER	CONDITIONS	MIN	TYP	MAX	UNITS	
NI/LI Input Current	$V_{BKSU} = V_{NI/LI} = 3.3V$	$T_A = +25^\circ C$	0.05	1	μA	
		$T_A = +85^\circ C$	0.1			
OD_ On-Resistance	$V_{BKSU} = 3.6V$		11	30	Ω	
OD_ Leakage Current	$V_{OD_} = 5.5V$	$T_A = +25^\circ C$	0.01	1	μA	
		$T_A = +85^\circ C$	0.1			
BACKUP STEP-UP (Note 2)						
BK Input Undervoltage Lockout	$V_{NI/LI} = 0V$, falling trip point		2.45		V	
	$V_{NI/LI} = V_{BKSU} = 3.3V$, falling trip point	1.05	1.12	1.21		
BK Input Voltage				5.5	V	
Quiescent Current into BKSU	$I_{LDO} = 0mA$, not switching		17	25	μA	
Quiescent Current into BK	$I_{BKSU} = I_{LDO} = 0mA$, not switching		2.4	4	μA	
Shutdown Current into BK	$V_{IN} = V_{INOK} = V_{BKSU} = 0V$	$T_A = +25^\circ C$	0.001	0.5	μA	
		$T_A = +85^\circ C$	0.1			
BKV Feedback Voltage		1.162	1.21	1.258	V	
BKV Feedback Bias Current	$V_{BKV} = 1V$	$T_A = +25^\circ C$	5	50	nA	
		$T_A = +85^\circ C$	10			
BKSU Output-Voltage Accuracy	$V_{BKV} = 0V$	3.17	3.3	3.43	V	
	$V_{BKV} = V_{BKSU}$	2.4	2.5	2.6		
BKSU Output Voltage Range		2.5		5	V	
n-Channel Switch On-Resistance	$I_{LX} = 200mA$		0.4	1	Ω	
p-Channel Switch On-Resistance	$I_{LX} = 200mA$		0.7	2	Ω	
LX Leakage Current		$T_A = +25^\circ C$	0.05	1	μA	
		$T_A = +85^\circ C$	0.1			
LX Current Limit (ILIM)		400	500	600	mA	
n-Channel Switch Maximum On-Time		3.5	5	6.5	μs	
p-Channel Zero-Channel Crossing Current		5	20	35	mA	
LOW-DROPOUT REGULATOR						
BKSU Input Voltage Range		2.7		5.0	V	
LDO Output-Voltage Accuracy	$V_{BKSU} = 3.3V$	MAX8568A	2.375	2.5	2.625	V
		MAX8568B	1.71	1.8	1.89	
LDO Line Regulation	$2.7V < V_{BKSU} < 5V$, $I_{LDO} = 1mA$		1		mV	
LDO Load Regulation	$1\mu A < I_{LDO} < 10mA$		2.5		mV	

Complete Backup-Management ICs for Lithium and NiMH Batteries

ELECTRICAL CHARACTERISTICS

(Circuit of Figure 7, $V_{IN} = V_{INOK} = 3.6V$, $V_{BK} = 1.4V$, $V_{NI/LI} = V_{BKSU} = 3.3V$, $V_{BKV} = GND = PGND = 0V$, $V_{STRTV} = V_{TERMV} = 1.2V$, $R_5 = 250k\Omega$, $T_A = -40^\circ C$ to $+85^\circ C$, unless otherwise noted. Typical values are at $T_A = +25^\circ C$.) (Note 3)

PARAMETER	CONDITIONS	MIN	MAX	UNITS
IN Voltage Range		2.8	5.5	V
IN Operating Current	Charger on, not including charge current		90	μA
CHGI Current Limit	$R_{CHGI} = 169k\Omega$, $V_{BK} = 1.3V$	8	12	mA
CHGI Resistor Range	$V_{BK} = 1.3V$	50	1800	$k\Omega$
BK Charge Voltage Limit	$V_{IN} = 5.5V$, $V_{NI/LI} = 0V$	4.116	4.310	V
	$V_{IN} = 3.8V$, $V_{NI/LI} = 0V$, $V_{TERMV} = 1V$	3.420	3.605	
	$V_{IN} = V_{NI/LI} = 3.6V$	1.746	1.854	
NiMH Mode BK High Threshold Voltage, $V_{BK(NIHI)}$	$V_{TERMV} = 1.2V$	1.37	1.43	V
NiMH Mode BK Low Threshold Voltage, $V_{BK(NILO)}$	$V_{STRTV} = 1.2V$	1.17	1.23	V
REF Output Voltage	$I_{REF} = 1\mu A$	1.225	1.275	V
REF Load Regulation	$I_{REF} = 1\mu A$ to $50\mu A$		10	mV
REF Line Regulation	$V_{IN} = 3V$ to $5.5V$, $I_{REF} = 1\mu A$		7	mV
INOK Threshold Voltage	V_{INOK} falling	2.38	2.48	V
	V_{INOK} rising	2.40	2.54	
NI/LI Logic-Level High	$V_{BKSU} = 3.3V$	1.8		V
NI/LI Logic-Level Low	$V_{BKSU} = 3.3V$		0.4	V
OD_ On-Resistance	$V_{BKSU} = 3.6V$		30	Ω
BACKUP STEP-UP (Note 2)				
BK Input Undervoltage Lockout	$V_{NI/LI} = V_{BKSU} = 3.3V$, falling trip point	1.05	1.21	V
BK Input Voltage			5.5	V
Quiescent Current into BKSU	$I_{LDO} = 0mA$, not switching		25	μA
Quiescent Current into BK	$I_{BKSU} = I_{LDO} = 0mA$, not switching		4	μA
BKV Feedback Voltage		1.162	1.258	V
BKSU Output-Voltage Accuracy	$V_{BKV} = 0V$	3.17	3.43	V
	$V_{BKV} = V_{BKSU}$	2.4	2.6	
BKSU Output Voltage Range		2.5	5.0	V
n-Channel Switch On-Resistance	$I_{LX} = 200mA$		1	Ω
p-Channel Switch On-Resistance	$I_{LX} = 200mA$		2	Ω

Complete Backup-Management ICs for Lithium and NiMH Batteries

ELECTRICAL CHARACTERISTICS (continued)

(Circuit of Figure 7, $V_{IN} = V_{INOK} = 3.6V$, $V_{BK} = 1.4V$, $V_{NI/LI} = V_{BKSU} = 3.3V$, $V_{BKV} = GND = PGND = 0V$, $V_{STRTV} = V_{TERMV} = 1.2V$, $R5 = 250k\Omega$, $T_A = -40^{\circ}C$ to $+85^{\circ}C$, unless otherwise noted. Typical values are at $T_A = +25^{\circ}C$.) (Note 3)

PARAMETER	CONDITIONS	MIN	MAX	UNITS	
LX Current Limit (ILIM)		400	600	mA	
n-Channel Switch Maximum On-Time		3.5	6.5	μs	
p-Channel Zero-Channel Crossing Current		5	35	mA	
LOW-DROPOUT REGULATOR					
BKSU Input Voltage Range		2.7	5.0	V	
LDO Output-Voltage Accuracy	$V_{BKSU} = 3.3V$	MAX8568A	2.375	2.625	V
		MAX8568B	1.71	1.89	

Note 1: All units are 100% production tested at $T_A = +25^{\circ}C$. Limits over the operating range are guaranteed by design.

Note 2: All backup step-up converter specifications are with $V_{IN} = V_{INOK} = 0V$, unless otherwise noted.

Note 3: Specifications to $-40^{\circ}C$ are guaranteed by design and not production tested.

Typical Operating Characteristics

(Circuit of Figure 7, $V_{IN} = 3.6V$, $V_{BK} = 1.4V$, $V_{NI/LI} = V_{BKSU} = 3.3V$, $T_A = +25^{\circ}C$, unless otherwise noted.)

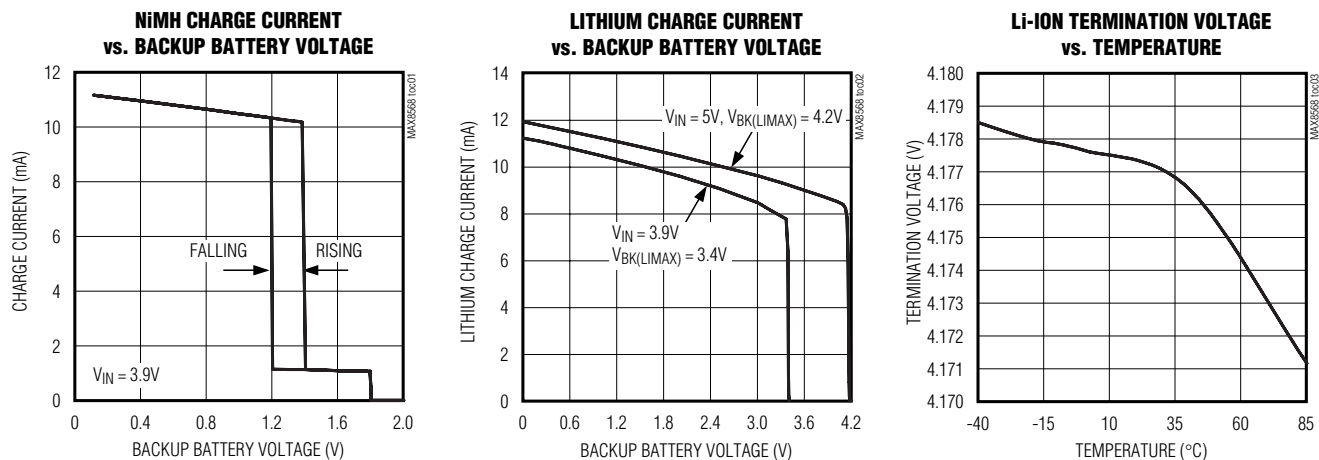

Complete Backup-Management ICs for Lithium and NiMH Batteries

Typical Operating Characteristics (continued)

(Circuit of Figure 7, $V_{IN} = 3.6V$, $V_{BK} = 1.4V$, $V_{NI/LI} = V_{BK/SU} = 3.3V$, $T_A = +25^\circ C$, unless otherwise noted.)

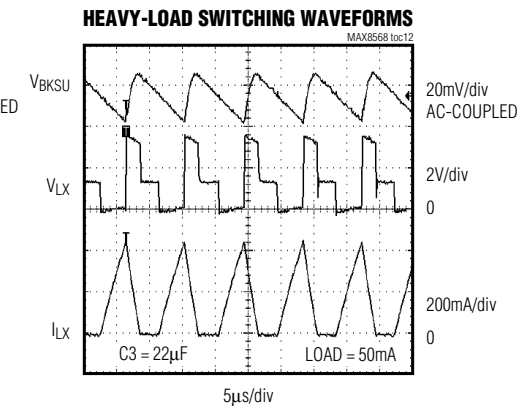
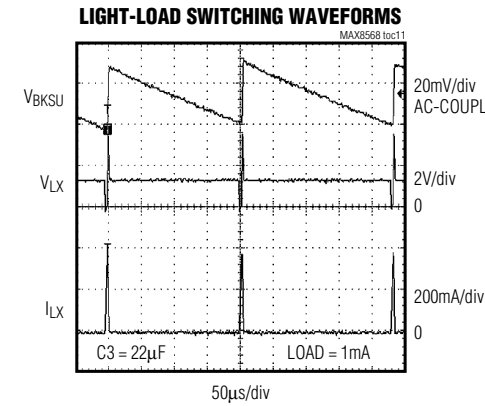
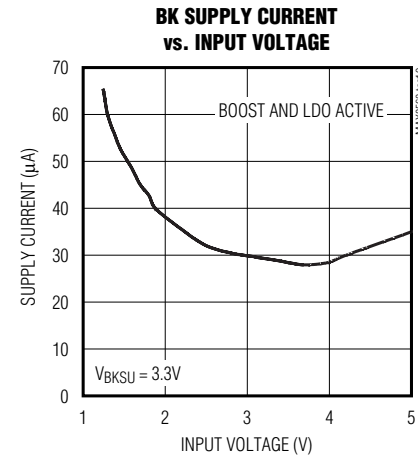
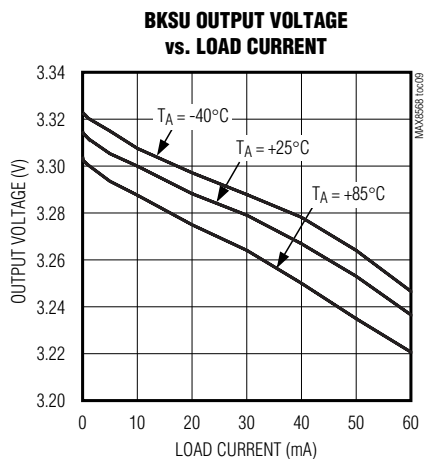
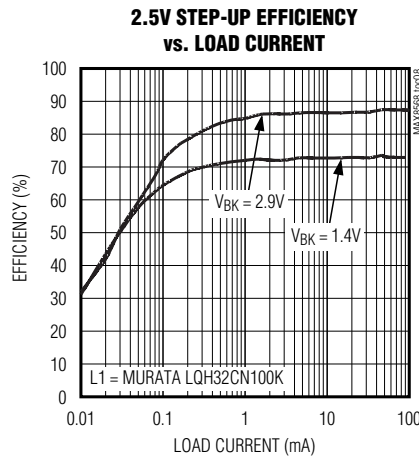
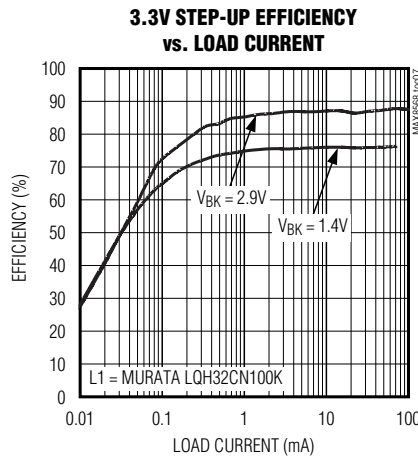
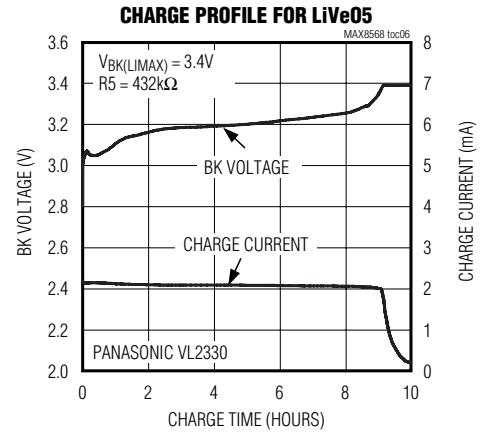
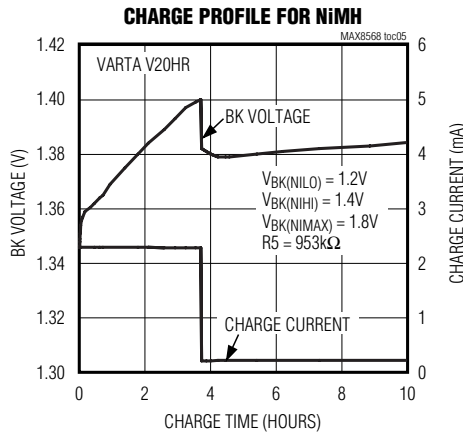
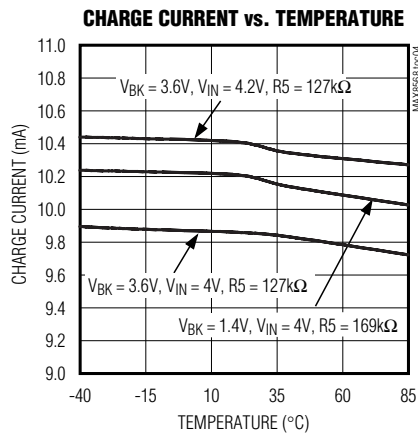

Complete Backup-Management ICs for Lithium and NiMH Batteries

Typical Operating Characteristics (continued)

(Circuit of Figure 7, $V_{IN} = 3.6V$, $V_{BK} = 1.4V$, $V_{NI/LI} = V_{BKSU} = 3.3V$, $T_A = +25^\circ C$, unless otherwise noted.)

MAX8568A/MAX8568B

MAIN-TO-BK TRANSITION WAVEFORMS

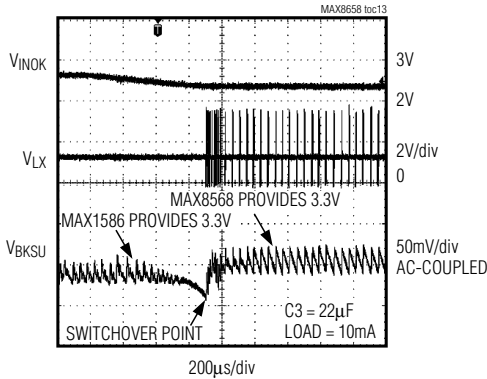

BKSU LOAD TRANSIENT

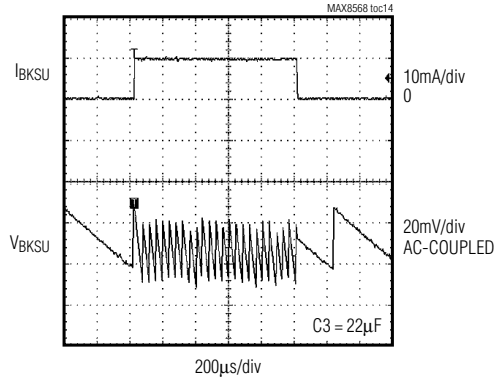

V_{BKSU} vs. LDO LOAD CURRENT

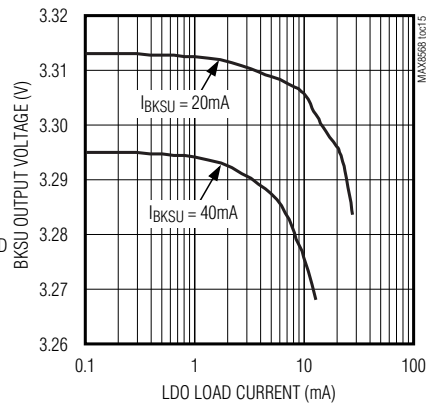

LDO OUTPUT VOLTAGE vs. BK INPUT VOLTAGE

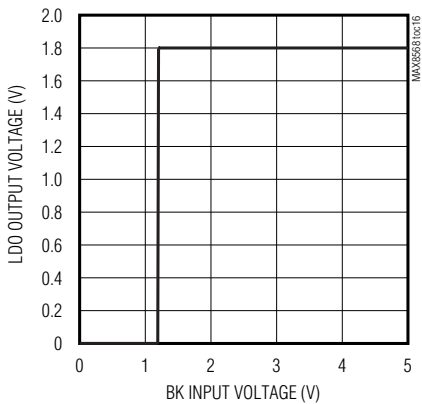

LDO LOAD TRANSIENT

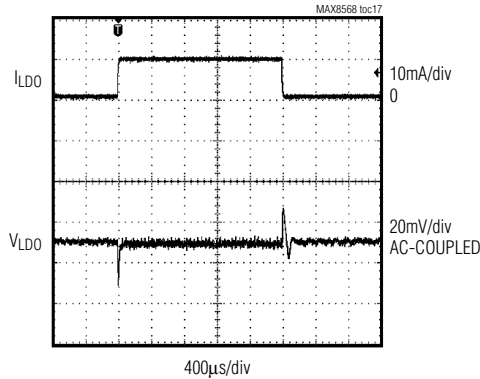

BKSU RESPONSE TO LDO LOAD TRANSIENT

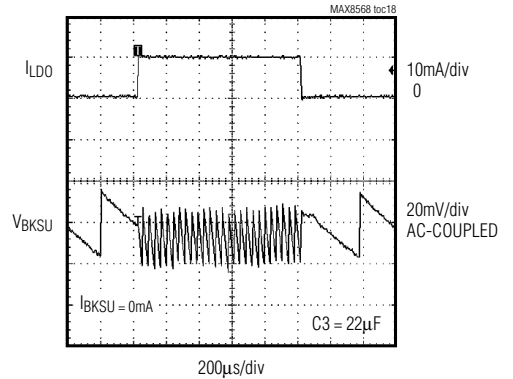

V_{INOK} FALLING

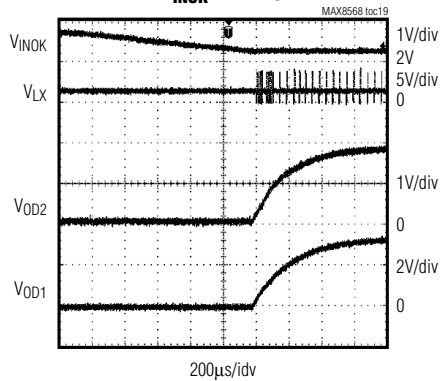

V_{INOK} RISING

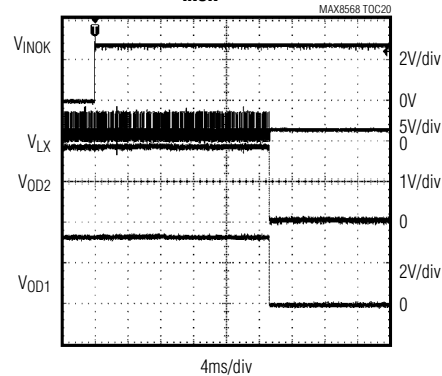

Complete Backup-Management ICs for Lithium and NiMH Batteries

Pin Description

PIN	NAME	FUNCTION
1	IN	Main Battery Input. Connect to a 2.8V to 5.5V battery or other power source. Bypass with a 4.7 μ F ceramic capacitor to GND.
2	BK	Backup Battery Input. Connect to an NiMH or rechargeable lithium backup battery. Connect a ceramic bypass capacitor from BK to GND. See the <i>Step-Up Capacitor Selection</i> section for more details.
3	PGND	Power Ground. Connect PGND to the ground side of the BK input capacitor and BKSU output capacitor. Use this connection as the star point for all grounds. See the <i>PC Board Layout and Routing</i> section for specific instructions regarding PGND.
4	LX	Inductor Connection for Low-I _Q Step-Up DC-DC Converter
5	BKSU	Step-Up Converter Output. Bypass with a 10 μ F to 22 μ F ceramic capacitor to PGND. The BKSU output voltage is set to either 3.3V or 2.5V without resistors, or to an adjustable voltage with an external resistor-divider. See the <i>Setting the Step-Up Converter Voltage</i> section.
6	LDO	2.5V (MAX8568A) or 1.8V (MAX8568B), 10mA LDO Output for Memory Supply. LDO is powered from BKSU. Bypass with a 4.7 μ F ceramic capacitor to GND.
7	OD1	11 Ω Open-Drain Output. OD1 drives the gate of an external pMOS switch.
8	OD2	11 Ω Open-Drain Output. OD2 drives the gate of an external pMOS switch.
9	NI/LI	Selects NiMH or Rechargeable Lithium Backup Battery. Connect NI/LI to BKSU if an NiMH backup battery is used. Connect NI/LI to GND if a rechargeable lithium backup battery is used.
10	BKV	Sets the BKSU Output Voltage. Connect to GND for 3.3V output at BKSU. Connect to BKSU for 2.5V output. Connect to the midpoint of a resistor-divider connected from BKSU to GND for adjustable output. See the <i>Setting the Step-Up Converter Voltage</i> section.
11	INOK	Main Battery Monitor. When V _{INOK} falls below 2.43V, charging stops and backup mode starts. The step-up converter and LDO turn on, and OD1 and OD2 go high impedance.
12	CHGI	Sets Backup Battery Charge Current. Connect a resistor from CHGI to GND to set the charge current. See the <i>Setting the Charge Current</i> section for details.
13	GND	Ground. Connect to the exposed paddle. Star all grounds at the BKSU output capacitor ground.
14	STRTV	Sets Fast-Charge Start Voltage for NiMH. See the <i>Using an NiMH Backup Battery</i> section.
15	TERMV	Sets Fast-Charge Stop Voltage for NiMH, as Well as the Battery Regulation Voltage for Both Rechargeable Lithium and Maximum Voltage for NiMH. See the <i>Using a Lithium Backup Battery</i> section and the <i>Using an NiMH Backup Battery</i> section.
16	REF	Reference Output. Bypass with a 0.22 μ F ceramic capacitor to GND.
EP	—	Exposed Paddle. Connect to the analog ground plane. EP also functions as a heatsink. Solder to the circuit-board analog ground plane.

Complete Backup-Management ICs for Lithium and NiMH Batteries

MAX8568A/MAX8568B

Detailed Description

The MAX8568A/MAX8568B are compact ICs for managing backup battery charging and utilization in PDAs and other smart handheld devices. The MAX8568A/MAX8568B are comprised of three major blocks: 1) A multichemistry charger for small lithium-ion, lithium-manganese, LiVeO₅, and NiMH batteries; 2) a small very-low-current step-up DC-DC converter that generates a boosted backup supply when the backup battery output is less than required; and 3) an LDO that supplies a second backup voltage to an additional system block (typically low-voltage RAM).

Multichemistry Charger

The backup battery charger charges most types of rechargeable lithium and NiMH cells. Charging current can be set up to 25mA by a resistor connected from CHGI to GND. The charger operates a current-limited voltage source for rechargeable lithium batteries, and switches between fast and trickle charging for NiMH batteries.

NiMH Charging Scheme

The NiMH charger operates at two different charge currents based upon the voltages at TERMV and STRTV.

VSTRTV sets the BK voltage below which fast charging (set by CHGI) occurs. VTERMV sets the upper BK trip point where fast charging stops and trickle charging begins, and also sets a maximum voltage limit for the NiMH battery. If VTERMV is 1.2V, then fast charge stops at $1.2 / 0.86 = 1.4V$, and the maximum voltage limit is $1.2 / 0.67 = 1.791V$.

An NiMH battery fast charges until it hits 1.4V set by VTERMV. The charger then switches to trickle charge at a current that is 10% of fast charge (set by CHGI). If the voltage drops (due to loading or self-discharge) to 1.2V (with VSTRTV = 1.2V), fast charge resumes. If the voltage then increases back to 1.4V (with VTERMV = 1.2V), trickle charge resumes. If the cell voltage reaches 1.8V, the charge current falls to zero.

Lithium Charging Scheme

When charging rechargeable lithium-type batteries, VTERMV sets the charging voltage while VSTRTV is unused. Charge current is set by a resistor from CHGI to GND. There is no trickle charge for lithium mode. This charging scheme is essentially a current-limited voltage source.

Step-Up DC-DC Converter

If an NiMH battery or lower-voltage rechargeable lithium battery is used for backup, it may be necessary to boost the battery voltage to 2.5V, 3.3V, or some other voltage to power RAM, RTC, or other devices. The step-up DC-DC converter is powered by the backup battery but requires

that the I/O supply be activated at least one time before the backup battery can be stepped up. This allows the end product to draw no backup battery current while “on the shelf” waiting for its first activation. The step-up DC-DC converter is enabled, and reaches regulation, 50μs (typ) after INOK falls below 2.43V (typ).

The step-up converter includes a built-in synchronous rectifier that reduces cost by eliminating the need for an external diode and improves overall efficiency. The converter also features a clamp circuit that reduces EMI due to inductor ringing. The output voltage is set to 3.3V or 2.5V by connecting BKV to either GND or BKSU, respectively. For adjustable output, connect BKV to a resistor-divider from BKSU to GND.

LDO

For designs that require two different backup voltages, the MAX8568 includes a small LDO that is powered from BKSU. This LDO can supply up to 10mA and uses only 5μA of operating current. The LDO output is preset to 2.5V in the MAX8568A and 1.8V in the MAX8568B. The LDO is activated after VINOK falls below 2.43V (typ).

Switchover Behavior

See Figure 1 for switchover timing. If the backup battery is connected to the system before main power, the MAX8568 remains off and draws very little current, typically less than 0.5μA. This allows the end product to draw no backup battery current while “on the shelf” waiting for its first activation. When main power is connected, the MAX8568 powers on, assuming the main battery is greater than 2.8V. The MAX8568 begins to charge the backup battery if needed (see the *Multichemistry Charger* section). The OD1 and OD2 outputs pull to GND and turn on the external p-channel MOSFETs. This allows the voltage on I/O IN and MEM IN (Figure 7) to pass through to the I/O OUT and MEM OUT outputs. These I/O and MEM voltages are typically provided by a MAX1586/MAX1587 power-supply IC.

INOK monitors the main battery voltage and activates the backup boost converter and LDO when the voltage on VINOK falls below 2.43V. The backup converter starts 50μs after VINOK falls. OD1 and OD2 go high impedance and turn off the external p-channel MOSFETs. These MOSFETs disconnect the I/O IN and MEM IN inputs from the load. This ensures that the I/O and MEM main supplies do not draw current from the backup source (MAX8568). The charger also turns off when INOK is less than 2.43V.

If the MAX8568 is being evaluated as a stand-alone device, note that the backup-battery boost converter will not operate unless I/O IN has been activated at least one time. The typical power removal sequence for testing is 1) main battery goes low, then 2) MEM IN and I/O IN go low.

Complete Backup-Management ICs for Lithium and NiMH Batteries

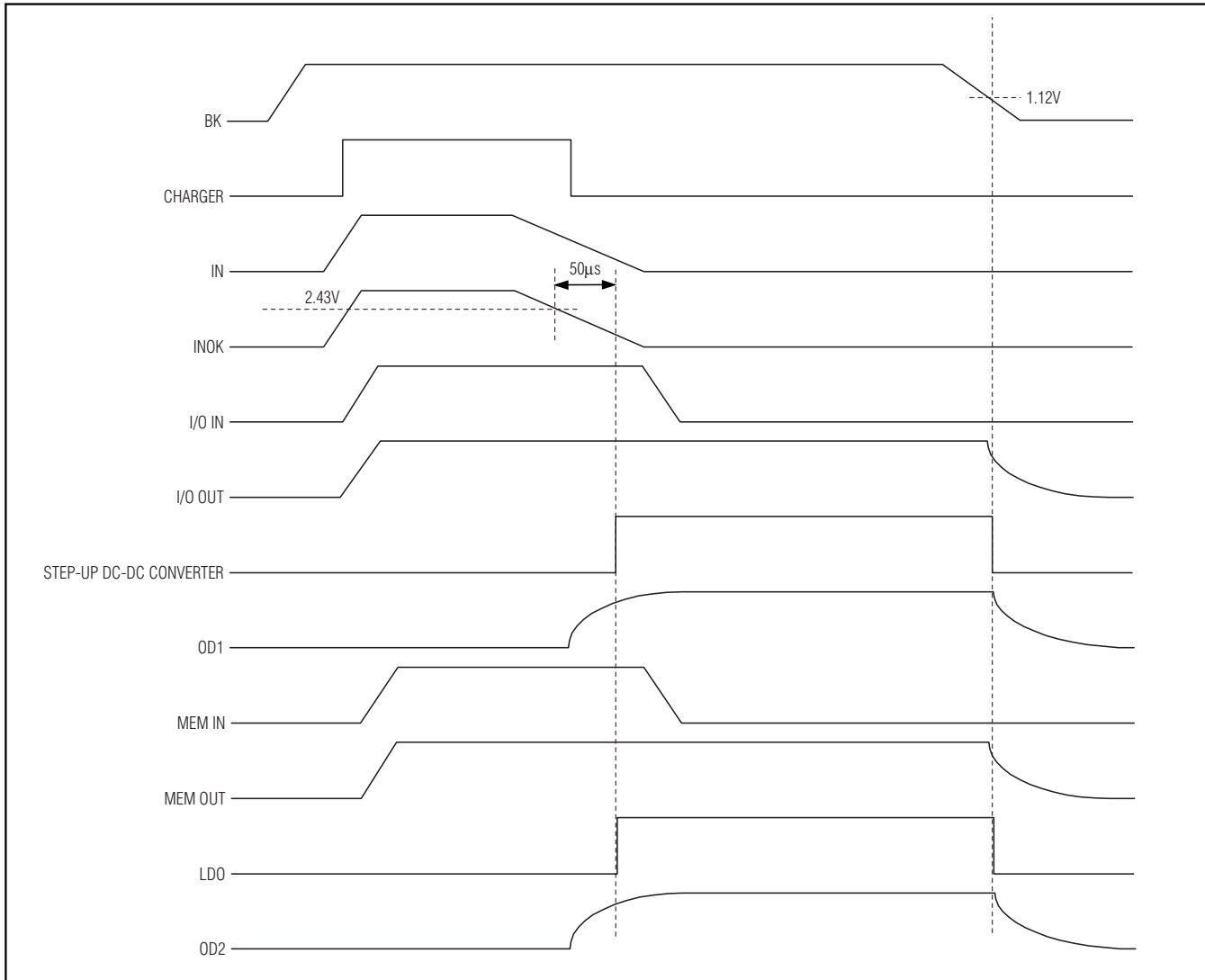

Figure 1. Timing Diagram

Applications Information

Setting the Charge Current

Charge current is set by a resistor connected from CHGI to GND (R5 in Figure 7). The acceptable resistor range is from 50kΩ to 1800kΩ. Charge current is calculated by the following.

$$\text{Charge Current} = \frac{1690}{R_{\text{CHGI}} + (\text{VIN} - \text{VBK} - 2.3) \times (1.05\text{mA/V})}$$

where VBK is the nominal voltage of the charged backup battery. For lithium batteries charging at low cur-

rents, desired R_{CHGI} may need to be determined empirically. This is the fast-charge current for both NiMH and lithium batteries. For NiMH batteries, the trickle charge is 10% of the fast-charge current.

Using a Rechargeable Lithium Backup Battery

The MAX8568 can charge a lithium-type backup battery from the main battery connected at IN. Connect NI/LI to GND for lithium backup battery charging. STRTV is unused and should be connected to GND in lithium charge mode.

Complete Backup-Management ICs for Lithium and NiMH Batteries

The lithium charger acts like a current-limited voltage source. The battery regulation voltage for lithium mode, $V_{BK(LIMAX)}$, is:

$$V_{BK(LIMAX)} = 3.5 \times V_{TERMV}$$

If $V_{TERMV} = 1.2V$, then the final charge voltage is 4.2V.

Connect $TERMV$ to a resistor-divider from REF to GND . Adjust V_{TERMV} with resistors $R11$ and $R12$ (Figure 2). Select $R12$ to be in the $100k\Omega$ to $1M\Omega$ range. Calculate $R11$ as follows:

$$R11 = R12 \left(\frac{3.5 \times V_{REF}}{V_{BK(LIMAX)}} - 1 \right)$$

where $V_{REF} = 1.25V$.

Using an NiMH Backup Battery

The MAX8568 can charge NiMH backup batteries from the main battery connected at IN . Connect NI/LI to $BKSU$ for NiMH backup battery charging. V_{TERMV} sets the maximum cell voltage and also the trip point for the fast-charge-to-trickle-charge transition. V_{STRTV} sets the trickle-to-fast-charge transition threshold.

In NiMH charge mode (NI/LI connected to $BKSU$), the charger ramps the battery between two thresholds measured at the battery connection BK , $V_{BK(NILO)}$ and $V_{BK(NIHI)}$. When the battery falls to $V_{BK(NILO)}$, trickle charging stops and fast charging starts. When the battery rises to $V_{BK(NIHI)}$, fast charging stops and trickle charging begins. If, for any reason, the battery contin-

ues to rise when trickle charged, all charging ceases at $V_{BK(NIMAX)}$. $V_{BK(NILO)}$, $V_{BK(NIHI)}$, and $V_{BK(NIMAX)}$ are set as follows:

BK voltage where fast charge begins:

$$V_{BK(NILO)} = V_{STRTV}$$

BK voltage where trickle charge begins:

$$V_{BK(NIHI)} = 1.163 \times V_{TERMV}$$

BK voltage where all charging stops:

$$V_{BK(NIMAX)} = 1.493 \times V_{TERMV}$$

Resistor-dividers (see Figure 3) set V_{STRTV} and V_{TERMV} by dividing down REF . To minimize operating current, resistors between $100k\Omega$ and $1M\Omega$ should be used for $R14$ and $R16$ in Figure 3. The formulas for the upper divider-resistors in terms of $V_{BK(NILO)}$, $V_{BK(NIHI)}$, and $V_{BK(NIMAX)}$ are:

$$R13 = R14 \left(\frac{V_{REF}}{V_{BK(NILO)}} - 1 \right)$$

$$R15 = R16 \left(\frac{1.163 \times V_{REF}}{V_{BK(NIHI)}} - 1 \right)$$

Once $V_{BK(NIHI)}$ is selected, the maximum battery voltage is:

$$V_{BK(NIMAX)} = 1.283 \times V_{BK(NIHI)}$$

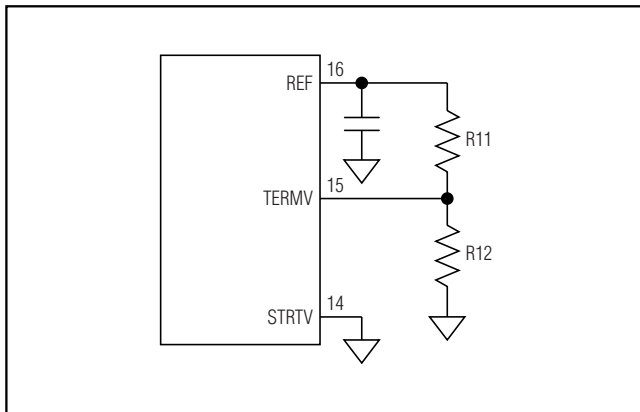

Figure 2. Resistor-Divider for Setting the Maximum Battery Voltage, $V_{BK(LIMAX)}$, for Rechargeable Lithium-Type Backup Batteries

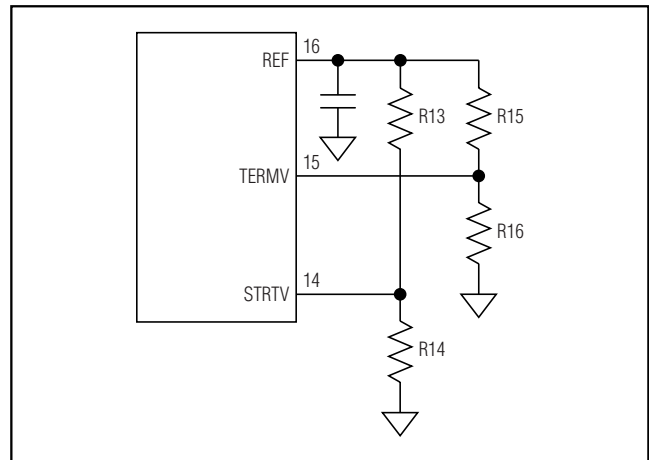

Figure 3. 2-Resistor-Dividers for Setting $V_{BK(NILO)}$ and $V_{BK(NIHI)}$

Complete Backup-Management ICs for Lithium and NiMH Batteries

Note that both $V_{BK(NILO)}$ and $V_{BK(NIHI)}$ can be set with a 2-resistor voltage-divider as shown in the typical application circuit (see Figure 7) if the factory-set ratio between the two thresholds is acceptable. In that case:

$$R6 = R8 \left(\frac{V_{REF}}{V_{BK(NILO)}} - 1 \right)$$

$$V_{BK(NIHI)} = 1.163 \times V_{BK(NILO)}$$

$$V_{BK(NIMAX)} = 1.283 \times V_{BK(NIHI)}$$

One 3-resistor-divider can be used to set both $V_{BK(NILO)}$ and $V_{BK(NIHI)}$ independently. Figure 4 shows the connections of R17, R18, and R19. Select R19 in the 100k Ω to 1M Ω range. The equations for the two upper divider-resistors are:

$$R18 = R19 \left(\frac{V_{REF}}{V_{BK(NILO)}} - 1 \right)$$

$$R17 = (R18 + R19) \times \left(\frac{1.163 \times V_{REF}}{V_{BK(NIHI)}} - 1 \right)$$

Setting the Switchover Voltage

V_{INOK} sets the IN voltage at which backup mode starts. INOK connects to a resistor-divider between IN and GND. The MAX8568 requires V_{IN} greater than 2.8V for proper operation when not backing up, so the backup threshold, $V_{IN(BACKUP)}$, must be set for no less than 2.8V. Once V_{INOK} drops below 2.43V (typ), V_{IN} may be less than 2.8V. The resistor-divider for INOK is shown in Figure 7 (R9 and R10). Select resistor R10 to be in the 100k Ω to 1M Ω range. Calculate R9 as follows:

$$R9 = R10 \left(\frac{V_{IN(BACKUP)}}{V_{INOK}} - 1 \right)$$

where $V_{INOK} = 2.43V$, and $V_{IN(BACKUP)}$ must be set greater than 2.8V.

Step-Up Converter

The step up DC-DC converter is most likely used with NiMH backup batteries, but can also be used with rechargeable lithium backup batteries. If the backup battery voltage is greater than the set output voltage at BKSU, the output voltage follows the backup battery voltage. The voltage difference between the backup battery and BKSU never exceeds a diode forward-voltage drop. If I/O OUT (Figure 7) is less than BK during charge mode, no current flows from BK to I/O OUT.

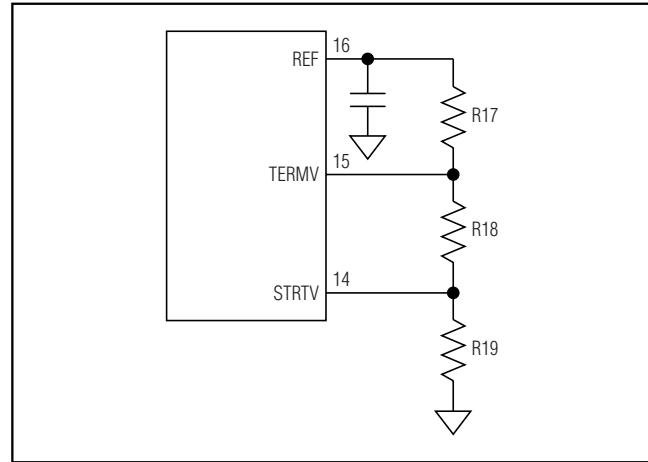

Figure 4. 3-Resistor Divider Used to Set $V_{BK(NILO)}$ and $V_{BK(NIHI)}$

Step-Up Capacitor Selection

Choose output capacitors to supply output peak currents with acceptable voltage ripple. Low equivalent-series-resistance (ESR) capacitors are recommended. Ceramic capacitors have the lowest ESR, but low-ESR tantalum or polymer capacitors offer a good balance between cost and performance.

Output voltage ripple has two components: variations in the charge stored in the output capacitor with each LX pulse and the voltage drop across the capacitor's ESR caused by the current into and out of the capacitor. The equations for calculating output ripple are:

$$V_{RIPPLE} = V_{RIPPLE(C)} + V_{RIPPLE(ESR)}$$

$$V_{RIPPLE(ESR)} = I_{PEAK} \times RESR(CBKSU)$$

$$V_{RIPPLE(C)} = \frac{1}{2} \left(\frac{L}{(V_{BKSU} - V_{BK}) C_{BKSU}} \right) I_{PEAK}^2$$

where I_{PEAK} is the peak inductor current (see the *Inductor Selection* section). For ceramic capacitors, the output voltage ripple is typically dominated by $V_{RIPPLE(C)}$.

Input capacitors connected to IN and BK should be X5R or X7R ceramic capacitors. C_{IN} should be 4.7 μF or greater. C_{BK} should be 10 μF or greater when using the step-up converter. If the step-up converter is not used, then C_{BK} can be reduced to 1 μF .

Capacitance and ESR variation with temperature should be considered for best performance in applications with wide operating temperature ranges.

Complete Backup-Management ICs for Lithium and NiMH Batteries

MAX8568A/MAX8568B

Inductor Selection

The control scheme of the MAX8568 permits flexibility in choosing an inductor. A 10μH inductor performs well in most applications. Smaller inductance values typically offer smaller physical size for a given series resistance, allowing the smallest overall circuit dimensions. Circuits using larger inductance may provide higher efficiency and exhibit less ripple, but also may reduce the maximum output current. This occurs when the inductance is sufficiently large to prevent the LX current limit (I_{LIM}) from being reached before the maximum on-time ($t_{ON(MAX)}$) expires.

For maximum output current, choose the inductor value so that the controller reaches the current limit before the maximum on-time is reached:

$$L < \frac{V_{BK} \times t_{ON(MAX)}}{I_{LIM}}$$

where $t_{ON(MAX)}$ is typically 5μs, and the current limit (I_{LIM}) is typically 500mA (see the *Electrical Characteristics* table).

For larger inductor values, determine the peak inductor current (I_{PEAK}) by:

$$I_{PEAK} = \frac{V_{BK} \times t_{ON(MAX)}}{L}$$

Setting the Output Voltage

The output voltage is set to 2.5V or 3.3V, or is adjustable. Connect BKV to GND for 3.3V, and BKV to BKSU for 2.5V. The adjustable output voltage is set from 2.5V to 5V using external resistors R1 and R2 (Figure 7). Since FB leakage is 50nA (max), select feedback resistor R2 in the 100kΩ to 1MΩ range. Calculate R1 as follows:

$$R1 = R2 \left(\frac{V_{BKSU}}{V_{BKV}} - 1 \right)$$

where $V_{BKV} = 1.21V$.

LDO

The LDO output voltage is preset to 2.5V for the MAX8568A and 1.8V for the MAX8568B. The LDO can supply up to 10mA. The LDO output voltage is not adjustable.

LDO Capacitor Selection

Capacitors are required at the LDO output of the MAX8568 for stable operation over the full load and temperature range. A 4.7μF or greater X5R or X7R ceramic capacitor is recommended. To reduce noise and improve load-transient response, larger output capacitors up to 10μF can be used. Surface-mount ceramic capacitors have very low ESR and are commonly available in values up to 10μF. Note that some ceramic dielectrics, such as Z5U and Y5V, exhibit large capacitance and ESR variation with temperature and require larger than the recommended values to maintain stability and good load-transient response over temperature.

External MOSFET Drivers—OD1, OD2

OD1 and OD2 are open-drain outputs and are designed to be connected to the gates of external p-channel MOSFETs (see Figure 7). These MOSFETs connect the main system power supplies (I/O IN and MEM IN) to the system loads (I/O OUT and MEM OUT) during normal operation. During backup, they disconnect the power supplies from the system loads to prevent the power supplies from drawing backup current away from the system. For this reason, the MOSFETs are connected “backwards” from what might be expected. The source of the MOSFETs are connected to the system load side (I/O OUT and MEM OUT). The MOSFETs’ purpose is to block current flow from the backup supply (BKSU) to the main supplies (I/O IN and MEM IN). They do not block current flow from I/O IN to I/O OUT and from MEM IN to MEM OUT. Even when off, the MOSFET body diodes allow current to pass in that direction.

OD1 is intended to drive the MOSFET switch for I/O IN and I/O OUT, while OD2 is intended to drive the MOSFET switch for MEM IN and MEM OUT. See the *Typical Operating Characteristics* and Figure 1 for typical operation of OD1 and OD2.

External MOSFET Selection

The external MOSFET should be chosen based upon $R_{DS(ON)}$ and gate capacitance. When $V_{INOK} > 2.43V$ (main battery $> 2.8V$), the current required for normal operation of I/O and MEM goes through these external MOSFETs. Choose an $R_{DS(ON)}$ that minimizes the MOSFET voltage drop. When $V_{INOK} < 2.43V$, the MOSFET turns off, and MEM and I/O are powered by the MAX8568. The gate capacitance of the external MOSFET must discharge through the external gate-to-source resistor. This discharge time determines how quickly the main supply is disconnected and isolated.

Complete Backup-Management ICs for Lithium and NiMH Batteries

Pullup resistors, R3 and R4 in Figure 7, should be selected to ensure that when OD1 and OD2 go high impedance, the gate of the external MOSFET discharges within 50 μ s to 100 μ s. This time allows the backup converters to start and provide power to I/O and MEM. Discharges longer than 50 μ s to 100 μ s could cause the main supply to back drain current from the MAX8568 and allow the I/O OUT and MEM OUT voltage to droop. The MOSFET gate-source resistor, R_{GS}, is calculated from the following formulas:

$$\tau = R_{GS} \times C_{ISS}$$

$$\tau = \frac{-50\mu\text{s}}{\ln\left(1 - \frac{V_{GS(TH)}}{V_{BKSU}}\right)}$$

where the MOSFET gate-source threshold, V_{GS(TH)}, and MOSFET input capacitance, C_{ISS}, are provided on the MOSFET data sheet.

Connection with MAX1586

When the MAX8568 is used with the MAX1586 system power supply, it may be preferable to employ the MAX1586's voltage monitors to determine when backup should start. The connection for this is shown in Figure 5 where the dead-battery output (DBO) of the MAX1586 drives the INOK input of the MAX8568. This, in effect, overrides the voltage-sensing circuit on the MAX8568 and uses the DBO monitor on the MAX1586. Refer to the MAX1586 data sheet for information on how to set the DBO threshold. The CHG connection in Figure 5 is described in the next section.

Terminating Charging at a Voltage Other than the Switchover Voltage

In normal operation, the MAX8568 charger is always active as long as the INOK voltage is valid (above 2.43V). In some systems, however, it may be desirable to terminate backup battery charging when the main battery is somewhat depleted but not so low as to trigger backup. An external voltage monitor, or a voltage monitor in a power-supply IC, such as the MAX1586, can disable charging by disconnecting the CHGI resistor. If CHGI is open, no charging current flows. This can be accomplished with the circuit in Figure 5. The low-battery output (LBO) of the MAX1586 pulls low when the battery falls below a user-set level (refer to the MAX1586 data sheet). This turns off the external n-channel MOSFET (or

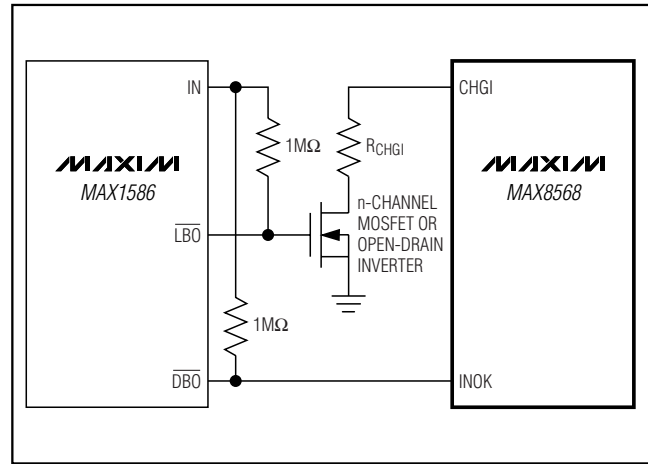

Figure 5. Using a MAX1586 Power-Supply IC to Trigger Backup Switchover and to Disable Backup Battery Charging Prior to Switchover

open-drain logic inverter) and disconnects the current path through R_{CHG}. Backup charging can be stopped for any reason using this method.

PC Board Layout and Routing

Careful PC board layout is important for minimizing ground bounce and noise. Ensure that C1 (IN input capacitor), C2 (BK input capacitor), C3 (BKSU bypass capacitor), and C4 (LDO output capacitor) are as close as possible to the IC. Avoid using vias to connect C2 or C3 to their respective pins or GND. C2 and C3 grounds should be next to each other, and this connection can then be used as the star ground point. All other grounds should connect to the star ground. PGND should star at C2 and C3, and should not connect directly to the exposed pad (EP) of the MAX8568. Connect EP to the bottom layer ground plane, and then connect the ground plane to the star ground. Vias on the inductor path are acceptable if necessary. IN, BK, BKSU, and LDO traces should be as wide as possible to minimize inductance. Refer to the MAX8568 evaluation kit for a PC board layout example.

Chip Information

TRANSISTOR COUNT: 7902

PROCESS: BiCMOS

Complete Backup-Management ICs for Lithium and NiMH Batteries

MAX8568A/MAX8568B

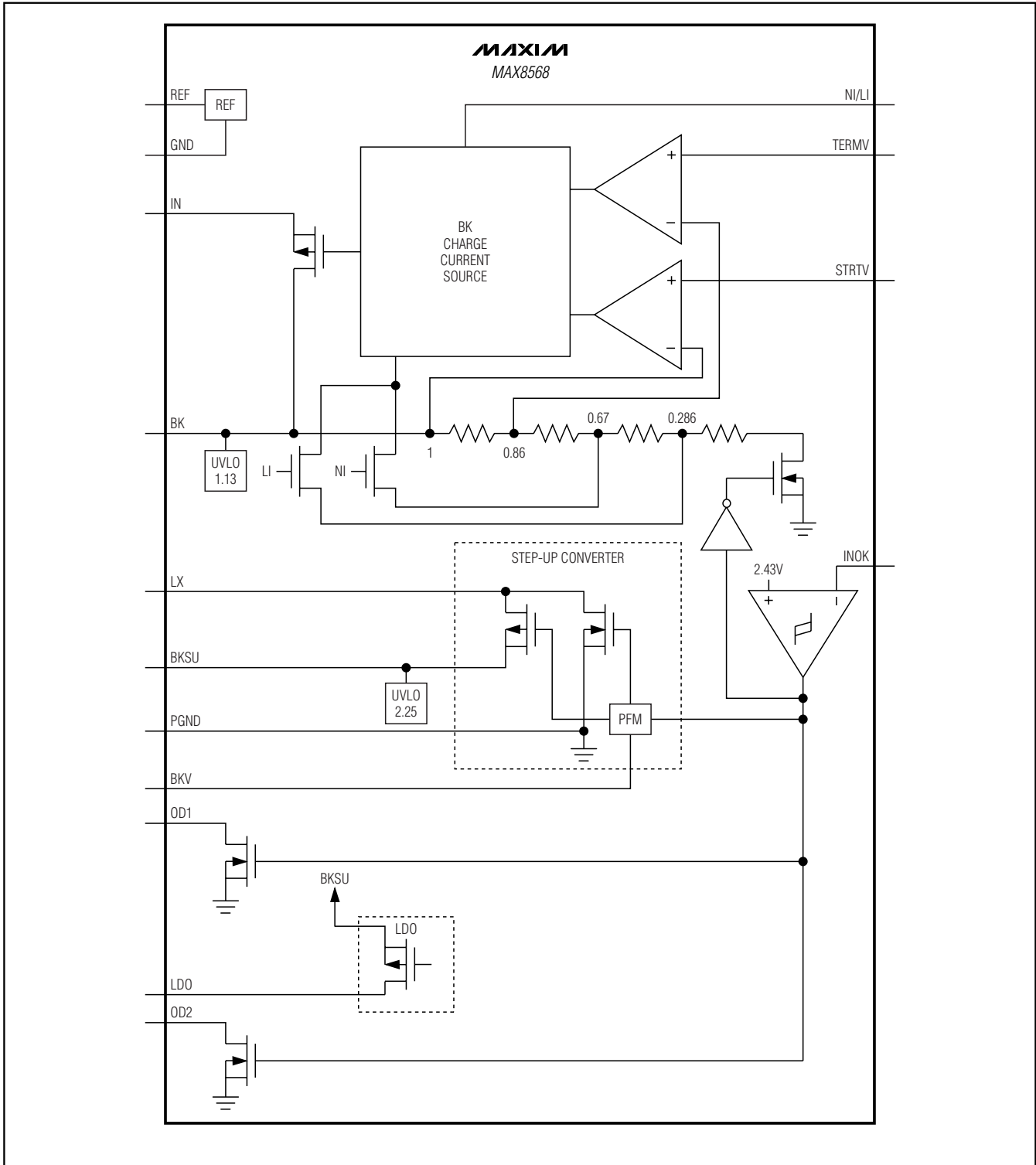

Figure 6. Functional Diagram

Complete Backup-Management ICs for Lithium and NiMH Batteries

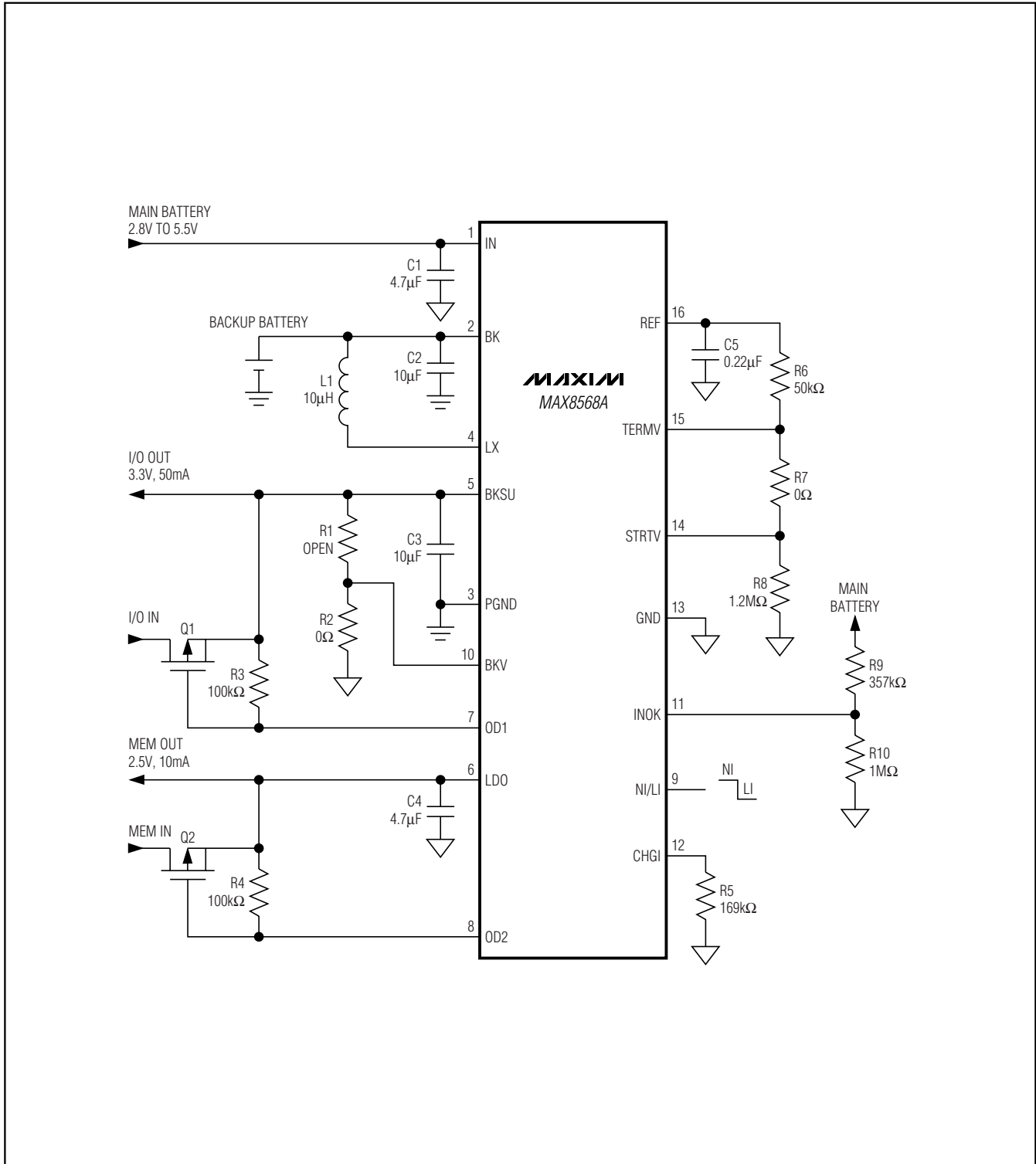

Figure 7. Typical Application Circuit

Complete Backup-Management ICs for Lithium and NiMH Batteries

Package Information

(The package drawing(s) in this data sheet may not reflect the most current specifications. For the latest package outline information, go to www.maxim-ic.com/packages.)

MAX8568A/MAX8568B

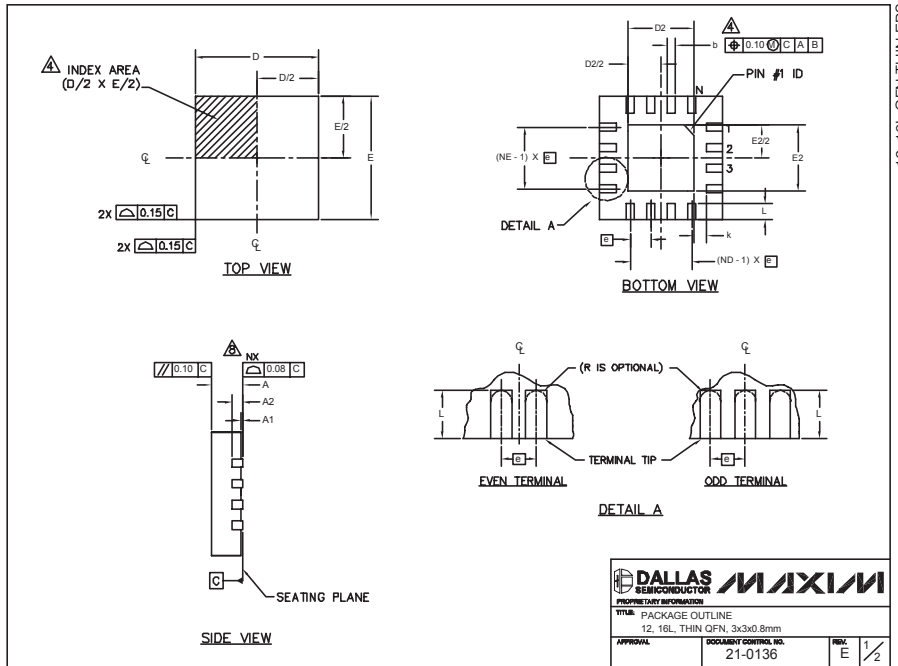

PKG	12L 3x3			16L 3x3		
REF.	MIN.	NOM.	MAX.	MIN.	NOM.	MAX.
A	0.70	0.75	0.80	0.70	0.75	0.80
b	0.20	0.25	0.30	0.20	0.25	0.30
D	2.90	3.00	3.10	2.90	3.00	3.10
E	2.90	3.00	3.10	2.90	3.00	3.10
e	0.50 BSC			0.50 BSC		
L	0.45	0.55	0.65	0.30	0.40	0.50
ND	3			4		
NE	3			4		
A1	0	0.02	0.05	0	0.02	0.05
A2	0.20 REF			0.20 REF		
k	0.25	-	-	0.25	-	-

PKG CODES	D2			E2			PIN ID	JEDEC	SOIN BONDS ALLOWED
	MIN.	NOM.	MAX.	MIN.	NOM.	MAX.			
T1233-1	0.95	1.10	1.25	0.95	1.10	1.25	0.35 x 45°	WEED-1	NO
T1233-3	0.95	1.10	1.25	0.95	1.10	1.25	0.35 x 45°	WEED-1	YES
T1833-1	0.85	1.10	1.25	0.85	1.10	1.25	0.35 x 45°	WEED-2	NO
T1833-2	0.85	1.10	1.25	0.95	1.10	1.25	0.35 x 45°	WEED-2	YES
T1833F-3	0.85	0.80	0.85	0.85	0.80	0.85	0.225 x 45°	WEED-2	N/A
T1833-4	0.85	1.10	1.25	0.95	1.10	1.25	0.35 x 45°	WEED-2	NO

NOTES:

- DIMENSIONING & TOLERANCING CONFORM TO ASME Y14.5M-1994.
- ALL DIMENSIONS ARE IN MILLIMETERS. ANGLES ARE IN DEGREES.
- N IS THE TOTAL NUMBER OF TERMINALS.
- THE TERMINAL #1 IDENTIFIER AND TERMINAL NUMBERING CONVENTION SHALL CONFORM TO JEDEC 95-1 SPP-012. DETAILS OF TERMINAL #1 IDENTIFIER ARE OPTIONAL, BUT MUST BE LOCATED WITHIN THE ZONE INDICATED. THE TERMINAL #1 IDENTIFIER MAY BE EITHER A MOLD OR MARKED FEATURE.
- DIMENSION b APPLIES TO METALLIZED TERMINAL AND IS MEASURED BETWEEN 0.20 mm AND 0.25 mm FROM TERMINAL TIP.
- ND AND NE REFER TO THE NUMBER OF TERMINALS ON EACH D AND E SIDE RESPECTIVELY.
- DEPOPULATION IS POSSIBLE IN A SYMMETRICAL FASHION.
- COPLANARITY APPLIES TO THE EXPOSED HEAT SINK SLUG AS WELL AS THE TERMINALS.
- DRAWING CONFORMS TO JEDEC MO220 REVISION C.

DALLAS SEMICONDUCTOR **MAXIM**

PROPRIETARY INFORMATION
TITLE: PACKAGE OUTLINE
12, 16L, THIN QFN, 3x3x0.8mm

APPROVAL	DOCUMENT CONTROL NO. 21-0136	REV.	E 2/2
----------	---------------------------------	------	-------

Maxim cannot assume responsibility for use of any circuitry other than circuitry entirely embodied in a Maxim product. No circuit patent licenses are implied. Maxim reserves the right to change the circuitry and specifications without notice at any time.

Maxim Integrated Products, 120 San Gabriel Drive, Sunnyvale, CA 94086 408-737-7600 _____ 17