

MAS9278

IC for 10.00 – 30.00 MHz VCXO

- Low Power
- Wide Supply Voltage Range
- True Sine Wave Output
- Very High Level of Integration
- Integrated Varactor
- Electrically Trimmable
- Very Low Phase Noise
- Low Cost

DESCRIPTION

The MAS9278 is an integrated circuit well suited to build VCXO for mobile communication. The crystal offset trimming is done through a serial bus and the calibration information is stored in an internal PROM.

To build a VCXO only one additional component, a crystal, is needed.

FEATURES

- Very small size
- Minor current draw
- Wide operating temperature range
- Phase noise <-130 dBc/Hz at 1 kHz offset
- Programmable Vc sensitivity

APPLICATIONS

- VCXO for mobile phones
- VCXO for other telecommunications systems
- Replacement for TCXO modules

BLOCK DIAGRAM

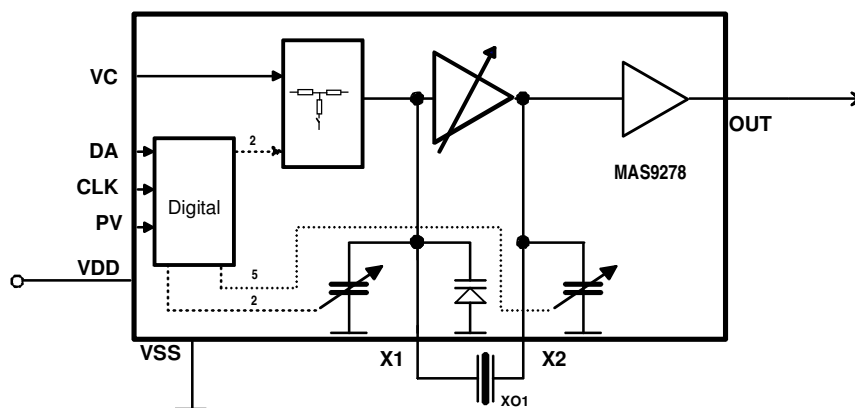

PIN DESCRIPTION

Pin Description	Symbol	x-coordinate	y-coordinate
Power Supply Voltage	VDD	177	172
Serial Bus Data Input	DA	435	1015
Serial Bus Clock Input	CLK	201	1015
Programming Input	PV	1042	1015
Voltage Control Input	VC	1012	158
Crystal Oscillator Output	X1	374	158
Power Supply Ground	VSS	830	1008
Crystal/Varactor Oscillator Input	X2	817	158
Buffer Output	OUT	665	1015

Note: Because the substrate of the die is internally connected to GND, the die has to be connected to GND or left floating. Make sure that GND is the first pad to be bonded. Pick-and-place and all component assembly are recommended to be performed in ESD protected area.

Note: Pad coordinates are measured from the left bottom corner of the chip to the center of the pads. The coordinates may vary depending on sawing width and location, however, distances between pads are accurate.

ABSOLUTE MAXIMUM RATINGS

Parameter	Symbol	Min	Max	Unit	Note
Supply Voltage	$V_{DD} - V_{SS}$	-0.3	6.0	V	
Input Voltage	V_{IN}	$V_{SS} - 0.3$	$V_{DD} + 0.3$	V	1)
Power Dissipation	P_{MAX}		20	mW	
Storage Temperature	T_{ST}	-55	150	°C	

Note: Not valid for programming pin PV.

RECOMMENDED OPERATION CONDITIONS

Parameter	Symbol	Conditions	Min	Typ	Max	Unit
Supply Voltage	V_{DD}		2.7	2.8	5.5	V
Supply Current	I_{CC}	$V_{CC} = 2.8$ Volt		0.85		mA
Operating Temperature	T_C		-30		+85	°C
Crystal Load Capacitance	C_L			7.0		pF

ELECTRICAL CHARACTERISTICS

(recommended operation conditions)

Parameter	Symbol	Min	Typ	Max	Unit	Note
Frequency Range	f_o	10.00		30.00	MHz	
Voltage Control Range	V_C	0		Vdd		
Voltage Control Sensitivity	V_{CSENS}		15..30		ppm/V	1)
Output Voltage (10k Ω // 10 pF)	V_{out}		1.0		Vpp	
Compensation CDAC1 (2 Bit)	C_{X1}	C10		C10 + 4.5	pF	2)
Compensation CDAC2 (4 Bit)	C_{X2}	C20		C20 + 18	pF	3)
Startup Time	T_{START}		2		ms	

Note 1: programmable by DN/DP switches

Note 2: typ C10 = 4.5 pF

Note 3: typ C20 = 12.5 pF

IC OUTLINES

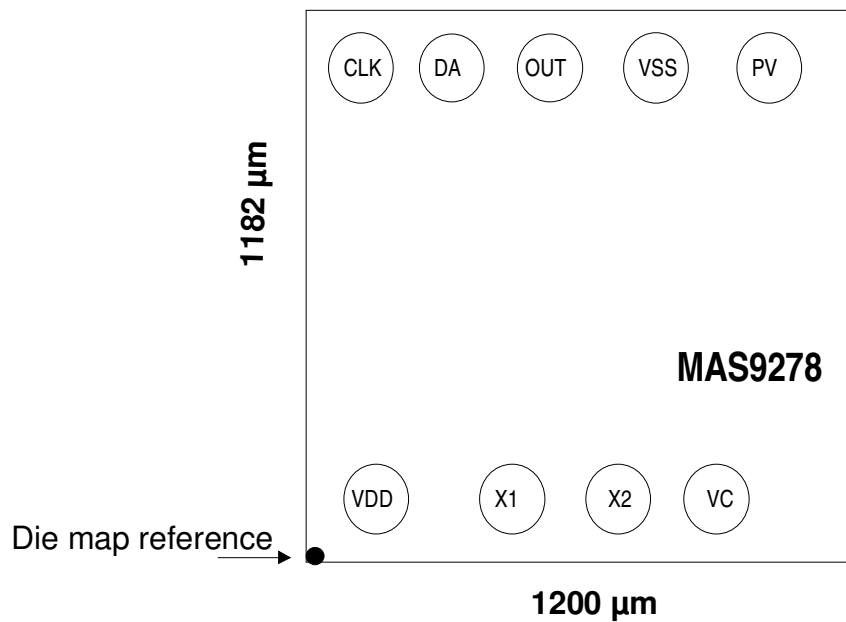

Note 1: MAS9278 pads are round with 80 μm diameter at opening.

Note 2: Pins CLK and DA can either be connected to VSS or left floating and pin PV can either be connected to VDD or left floating in VCXO module end-user application.

Note 3: Die map reference is the actual left bottom corner of the sawn chip.

SAMPLES IN SB20 DIL PACKAGE

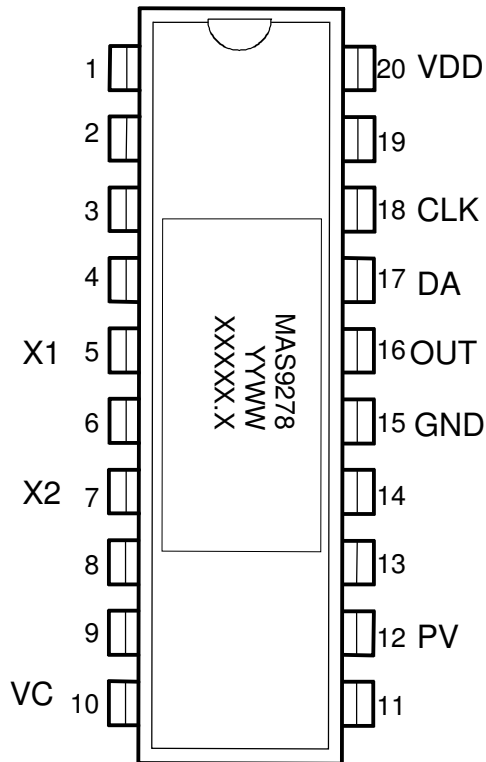

Top marking:
YYWW = Year, Week
XXXXX.X = Lot number

ORDERING INFORMATION

Product Code	Version	Package	Comments
MAS9278ATG1	A	EWS tested wafers 215 µm	Larger range of VC sensitivity
MAS9278A	A	SMD Package TBD	Larger range of VC sensitivity
MAS9278B1TG00	B	EWS tested wafers 215 µm	Smaller range of VC sensitivity

See DAE9278 page 4 for definition of versions.

Please contact Micro Analog Systems Oy for other wafer thickness options.

LOCAL DISTRIBUTOR

--

MICRO ANALOG SYSTEMS OY CONTACTS

Micro Analog Systems Oy Kutomotie 16 FI-00380 Helsinki, FINLAND	Tel. +358 10 835 1100 Fax +358 10 835 1119 http://www.mas-oy.com
---	--

NOTICE

Micro Analog Systems Oy reserves the right to make changes to the products contained in this data sheet in order to improve the design or performance and to supply the best possible products. Micro Analog Systems Oy assumes no responsibility for the use of any circuits shown in this data sheet, conveys no license under any patent or other rights unless otherwise specified in this data sheet, and makes no claim that the circuits are free from patent infringement. Applications for any devices shown in this data sheet are for illustration only and Micro Analog Systems Oy makes no claim or warranty that such applications will be suitable for the use specified without further testing or modification.