

APPLICATIONS

- High Frequency High Power Choppers And Inverters.
- Ultrasonic Generators.
- Welding.
- PWM Inverters.

KEY PARAMETERS

V_{DRM}	1400V
I_{TSM}	2000A
$I_{T(AV)}$ per arm	110A
V_{isol}	2500V
t_q	10/12/15μs

DESCRIPTION

The MAS 110S is a fast thyristor/diode module in an electrically isolated package. The semiconductors are pressure contact mounted giving high resistance to thermal fatigue, and having excellent heat dissipation qualities.

Isolation medium is non-toxic alumina.

The MAS110S is recognised under the 'Recognised Component Program of Underwriters Laboratories Inc. USA. File number E151069. 

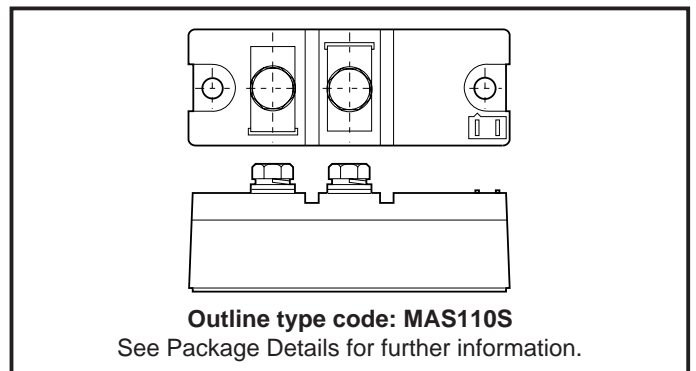

Fig.1 Package outline (not to scale)

VOLTAGE RATINGS

Type Number	Repetitive Peak Off-state Voltage V_{DRM} V	Conditions
MAS110S 14	1400	$T_{vj} = 125^{\circ}C,$ $I_{DRM} = 50mA,$ $V_{DSM} = V_{DRM} + 100V$
MAS110S 12	1200	
MAS110S 10	1000	
MAS110S 08	800	
MAS110S 06	600	

For full description of part number see 'Ordering Information'.

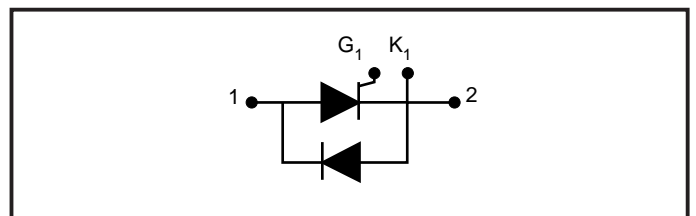

Fig.2 Single circuit

THYRISTOR CURRENT RATINGS

Symbol	Parameter	Conditions	Max.	Units
$I_{T(AV)}$	Mean forward current	Half wave resistive load, $T_{case} = 75^{\circ}C$	110	A
$I_{T(RMS)}$	RMS value	$T_{case} = 75^{\circ}C$	175	A

MAS110S

THYRISTOR SURGE RATINGS

Symbol	Parameter	Conditions	Max.	Units
I_{TSM}	Surge (non-repetitive) on-state current	10ms half sine; $T_{case} = 125^{\circ}C$	2.0	kA
I^2t	I^2t for fusing	$V_R = 0\% V_{DRM}$	20.0×10^3	A ² s

THYRISTOR DYNAMIC CHARACTERISTICS

Symbol	Parameter	Conditions	Min.	Max.	Units	
V_{TM}	Maximum on-state voltage	At 600A peak, $T_{case} = 25^{\circ}C$	-	2.9	V	
I_{DRM}	Peak off-state current	At V_{DRM} , $T_{case} = 125^{\circ}C$	-	70	mA	
dV/dt	Maximum linear rate of rise of off-state voltage	To 60% V_{DRM} , $T_j = 125^{\circ}C$, Gate open circuit	-	1000	V/ μ s	
dI/dt	Rate of rise of on-state current	From 67% V_{DRM} to 600A, Gate source 20V, 20 Ω $t_r = < 0.5\mu$ s, $T_j = 125^{\circ}C$	Repetitive 50Hz	-	500	A/ μ s
$V_{T(TO)}$	Threshold voltage	At $T_{vj} = 125^{\circ}C$	-	1.6	V	
r_T	On-state slope resistance	At $T_{vj} = 125^{\circ}C$	-	1.4	m Ω	
t_q	Turn-off time	$I_T = 100A$, $T_j = 125^{\circ}C$, $dI_R/dt = 30A/\mu$ s, $V_{GK} = 0V$ $dV/dt = 20V/\mu$ s to 60% V_{DRM} , $V_R = 1V$.	t_q code: W	-	10	μ s
			t_q code: S	-	12	μ s
			t_q code: X	-	15	μ s

THYRISTOR GATE TRIGGER CHARACTERISTICS AND RATINGS

Symbol	Parameter	Conditions	Typ.	Max.	Units
V_{GT}	Gate trigger voltage	$V_{DRM} = 12V, T_{case} = 25^{\circ}C, R_L = 30\Omega$	-	4.0	V
I_{GT}	Gate trigger current	$V_{DRM} = 12V, T_{case} = 25^{\circ}C$	-	250	mA
V_{RGM}	Peak reverse gate voltage		-	7.0	V
I_{FGM}	Peak forward gate current	Anode positive with respect to cathode	-	10	A
P_{GM}	Peak gate power	-	-	50	W
$P_{G(AV)}$	Mean gate power	Average timing = 10ms	-	15	W

DIODE CURRENT RATINGS

Symbol	Parameter	Conditions	Max.	Units
$I_{T(AV)}$	Mean forward current	Half wave resistive load, $T_{case} = 75^{\circ}C$	112	A
$I_{T(RMS)}$	RMS value	$T_{case} = 75^{\circ}C$	175	A

DIODE SURGE RATINGS - PER ARM

Symbol	Parameter	Conditions	Max.	Units
I_{FSM}	Surge (non-repetitive) forward current	10ms half sine; $T_{case} = 130^{\circ}C$	3.5	kA
I^2t	I^2t for fusing	$V_R = 0\% V_{RRM}$	61.25×10^3	A^2s

DIODE DYNAMIC CHARACTERISTICS

Symbol	Parameter	Conditions	Max.	Units
V_{FM}	Forward voltage	At 600A, $T_{case} = 25^{\circ}C$.	2.65	V
I_{RRM}	Peak reverse current	At $V_{RRM}, T_{case} = 125^{\circ}C$.	70	mA
t_{rr}	Reverse recovery time	$T_{case} = 125^{\circ}C, di_R/dt = -50V/\mu s, I_{FM} = 200A$	1.3	μs
V_{TO}	Threshold voltage	At $T_{vj} = 125^{\circ}C$.	1.6	V
r_T	Forward slope resistance	At $T_{vj} = 125^{\circ}C$.	1.5	m Ω

MAS110S

THERMAL AND MECHANICAL DATA

Symbol	Parameter	Conditions	Min.	Max.	Units
$R_{th(j-c)}$	Thermal resistance - junction to case (Thyristor or diode)	dc	-	0.21	°C/W
$R_{th(c-h)}$	Thermal resistance - case to heatsink (Thyristor or diode)	Mounting force 6Nm with mounting compound.	-	0.07	°C/W
T_{vj}	Virtual junction temperature	-	-	125	°C
T_{op}	Operating temperature range	-	-40	125	°C
T_{stg}	Storage temperature range	-	-40	125	°C
V_{isol}	Isolation voltage	Commoned terminals to base plate. AC RMS, 1 min, 50Hz.	-	2.5	kV
-	Mounting torque	-	-	6.0	Nm

ORDERING INFORMATION

The module type number is made up as follows:

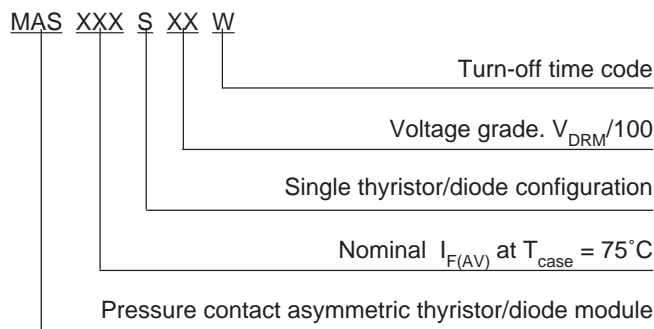

Examples:

MAS 110 S 12 W
MAS 110 S 08 X

MODULE MOUNTING RECOMMENDATIONS

■ Adequate heatsinking is required to maintain the base temperature at 75°C if full rated current is to be achieved. Power dissipation may be calculated by use of $V_{T(TO)}$ and r_T information and loss curves in accordance with standard formulae. We can provide assistance with calculations or choice of heatsink if required.

■ The heatsink surface must be smooth and flat; a surface finish of N6 (32µin) and a flatness within 0.05mm (0.002") are recommended.

■ Immediately prior to mounting, the heatsink surface should be lightly scrubbed with fine emery, Scotch Brite™ or a mild chemical etchant and then cleaned with a solvent to remove oxide build up and foreign material. Care should be taken to ensure no foreign particles remain.

■ An even coating of thermal compound (eg. Unial) should be applied to both the heatsink and module mounting surfaces. This should ideally be 0.05mm (0.002") per surface to ensure optimum thermal performance.

■ After application of thermal compound, place the module squarely over the mounting holes, (or 'T' slots) in the heatsink. Using a torque wrench, slowly tighten the recommended fixing bolts at each end, rotating each in turn no more than 1/4 of a revolution at a time. Continue until the required torque of 6Nm (55lb.ins) is reached at both ends.

■ It is not acceptable to fully tighten one fixing bolt before starting to tighten the others. Such action may DAMAGE the module.

Curves

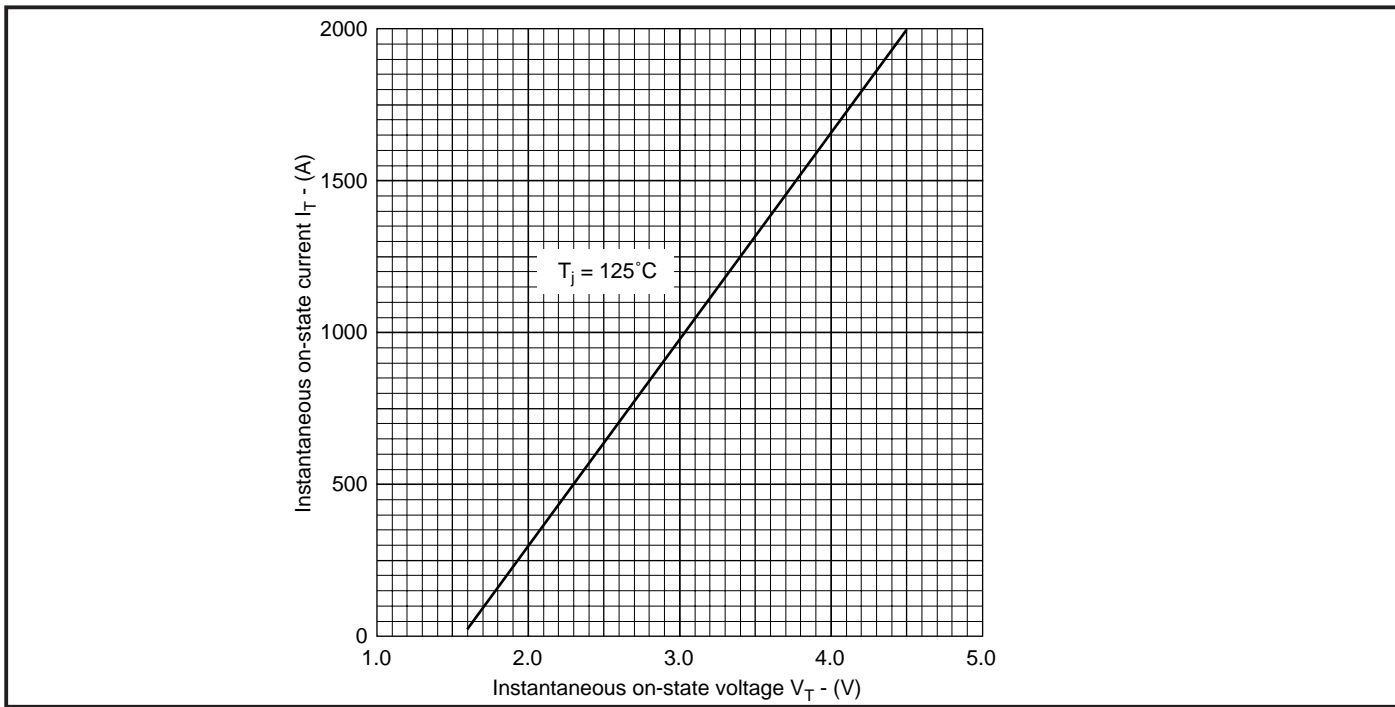

Fig.3 Maximum (limit) on-state characteristics (thyristor only)

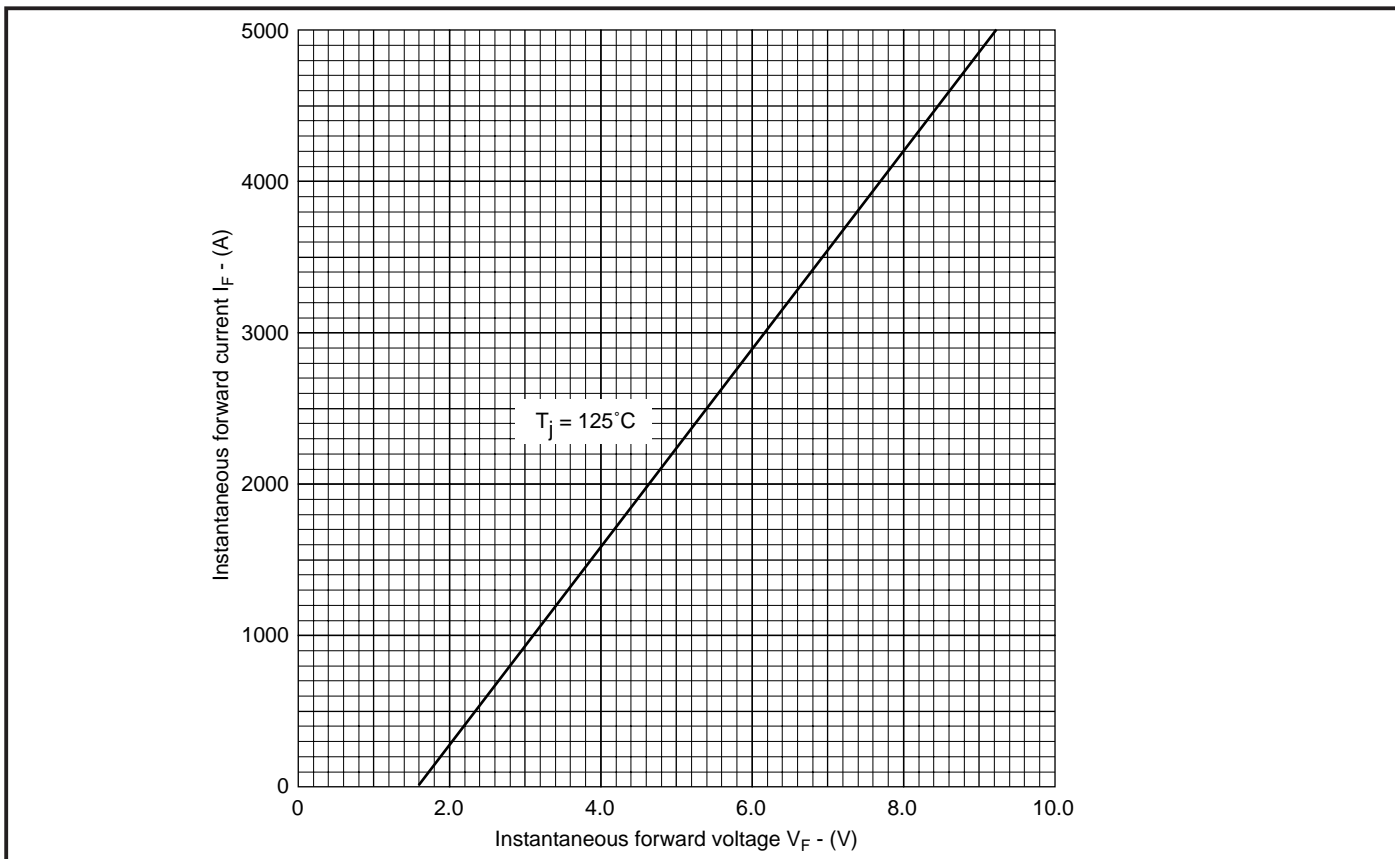
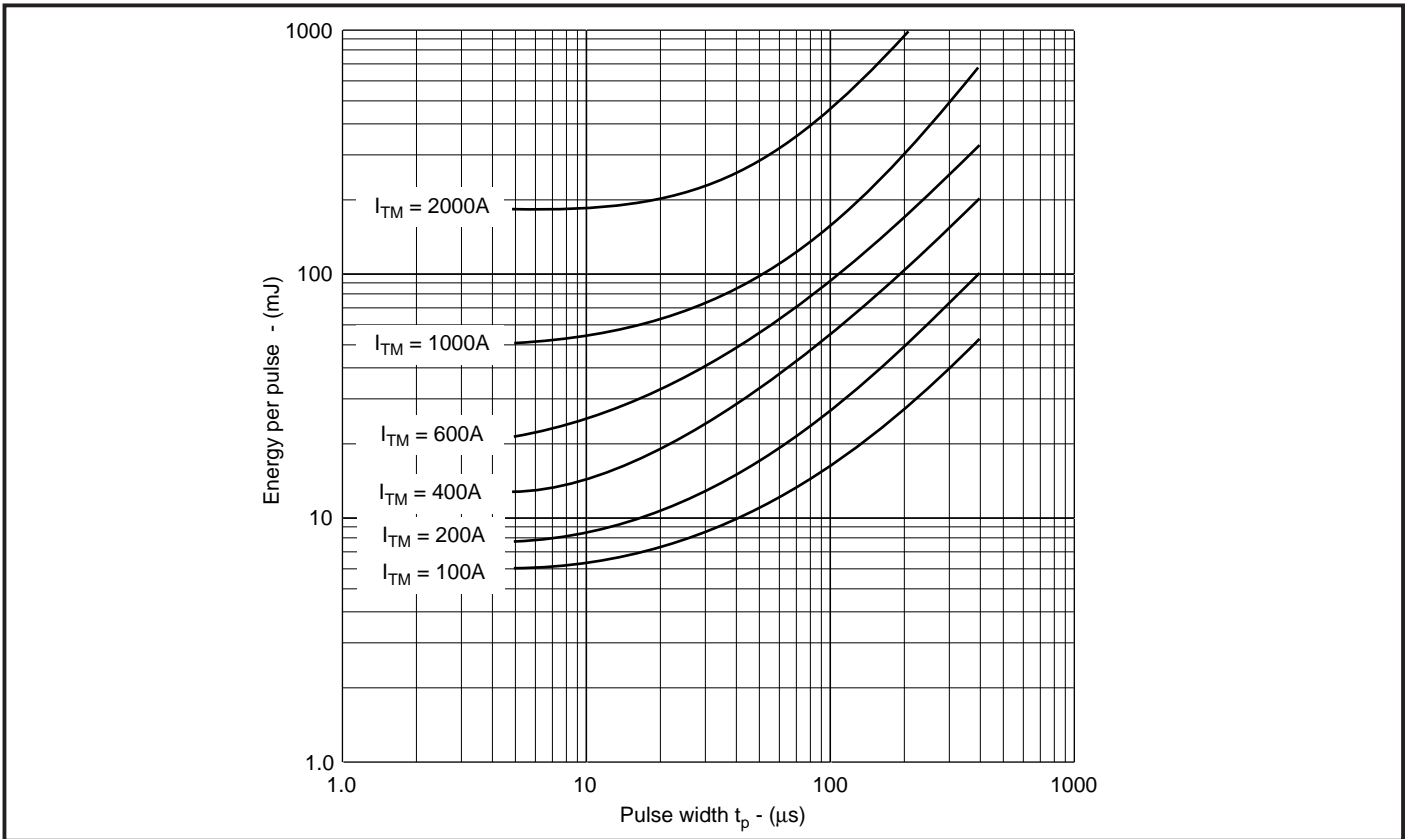
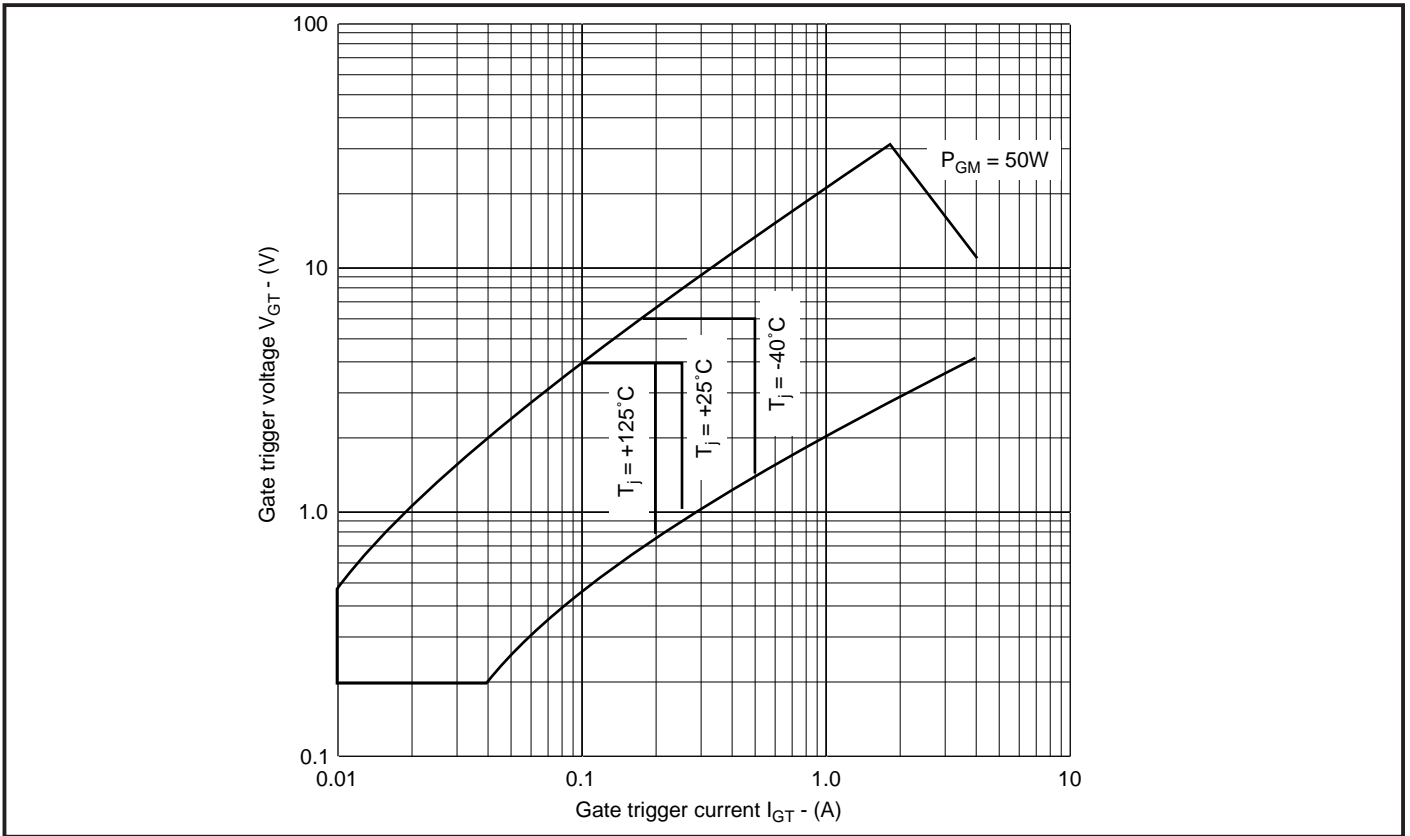

Fig.4 Maximum (limit) forward characteristics (diode only)



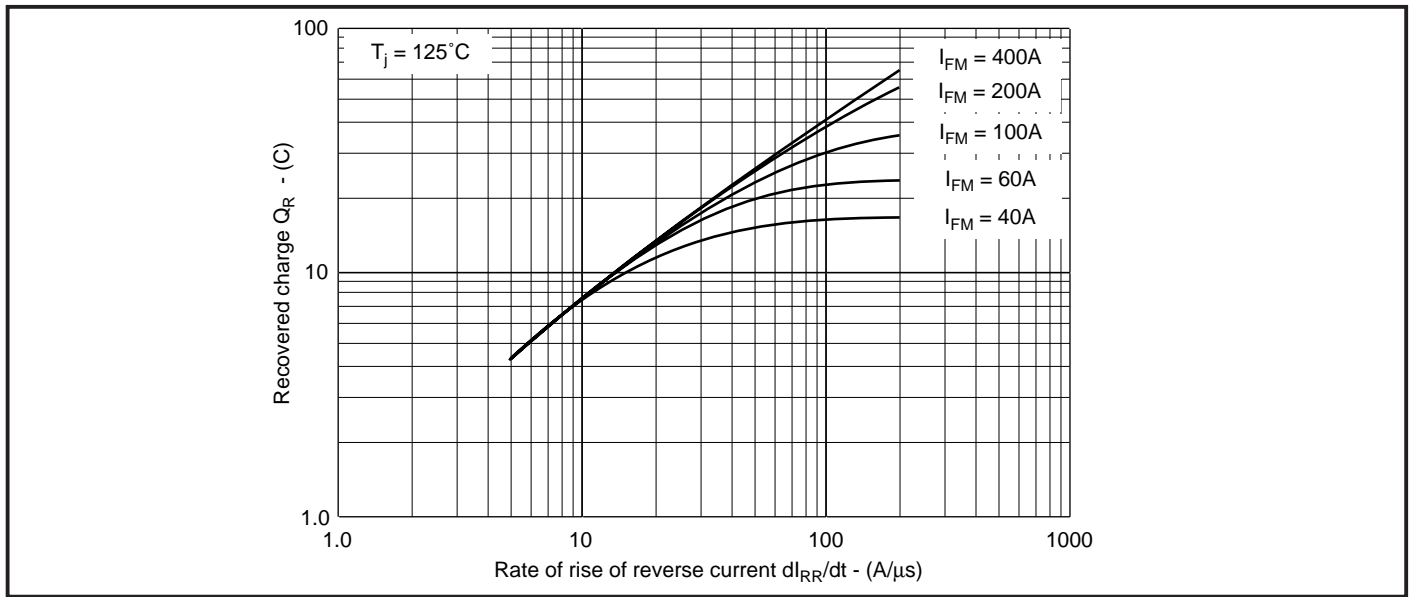

Fig.7 Recovered charge (diode only)

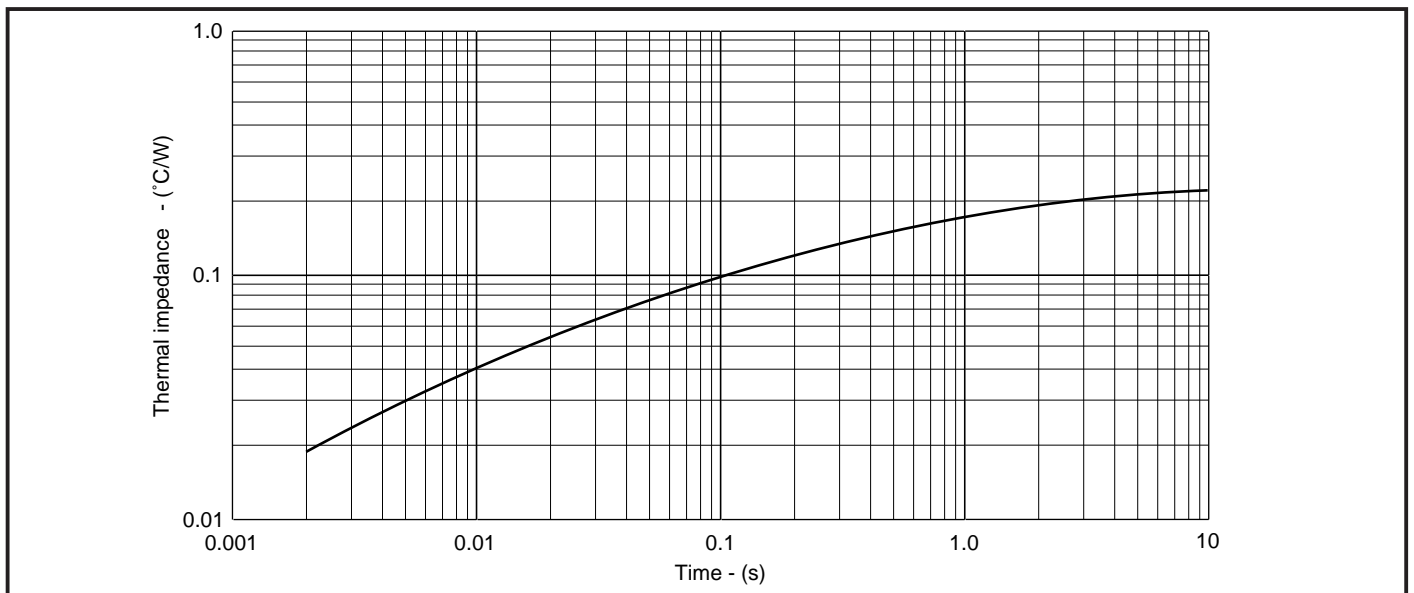
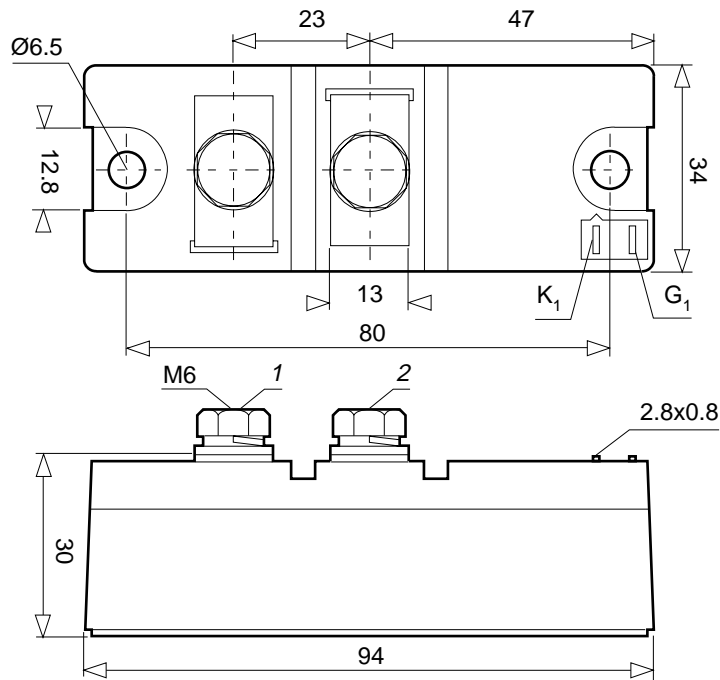

Fig.8 Maximum (limit) transient thermal impedance (thyristor only)

MAS110S

PACKAGE DETAILS

For further package information, please contact your local Customer Service Centre. All dimensions in mm, unless stated otherwise. DO NOT SCALE.



Recommended fixings for mounting:	M6 socket head cap screws.
Recommended mounting torque:	6Nm (55lb.ins)
Recommended torque for electrical connections:	5Nm (44lb.ins)
Maximum torques for electrical connections:	8Nm (70lb.ins)
Nominal weight:	350g

Module outline type code: MP02

POWER ASSEMBLY CAPABILITY

The Power Assembly group was set up to provide a support service for those customers requiring more than the basic semiconductor, and has developed a flexible range of heatsink / clamping systems in line with advances in device types and the voltage and current capability of our semiconductors.

We offer an extensive range of air and liquid cooled assemblies covering the full range of circuit designs in general use today. The Assembly group continues to offer high quality engineering support dedicated to designing new units to satisfy the growing needs of our customers.

Using the up to date CAD methods our team of design and applications engineers aim to provide the Power Assembly Complete solution (PACs).

HEATSINKS

Power Assembly has its own proprietary range of extruded aluminium heatsinks. They have been designed to optimise the performance of our semiconductors. Data with respect to air natural, forced air and liquid cooling (with flow rates) is available on request.

For further information on device clamps, heatsinks and assemblies, please contact your nearest Sales Representative or the factory.



<http://www.dynexsemi.com>

e-mail: power_solutions@dynexsemi.com

HEADQUARTERS OPERATIONS
DYNEX SEMICONDUCTOR LTD
 Doddington Road, Lincoln.
 Lincolnshire, LN6 3LF, United Kingdom.
 Tel: 00-44-(0)1522-500500
 Fax: 00-44-(0)1522-500550

DYNEX POWER INC.
 Unit 7 - 58 Antares Drive,
 Nepean, Ontario, Canada K2E 7W6.
 Tel: 613.723.7035
 Fax: 613.723.1518
 Toll Free: 1.888.33.DYNEX (39639)

CUSTOMER SERVICE CENTRES
France, Benelux, Italy and Spain Tel: +33 (0)1 69 18 90 00. Fax: +33 (0)1 64 46 54 50
North America Tel: 011-800-5554-5554. Fax: 011-800-5444-5444
UK, Germany, Scandinavia & Rest Of World Tel: +44 (0)1522 500500. Fax: +44 (0)1522 500020

SALES OFFICES
France, Benelux, Italy and Spain Tel: +33 (0)1 69 18 90 00. Fax: +33 (0)1 64 46 54 50
Germany Tel: 07351 827723
North America Tel: (613) 723-7035. Fax: (613) 723-1518. Toll Free: 1.888.33.DYNEX (39639) /
 Tel: (831) 440-1988. Fax: (831) 440-1989 / Tel: (949) 733-3005. Fax: (949) 733-2986.
UK, Germany, Scandinavia & Rest Of World Tel: +44 (0)1522 500500. Fax: +44 (0)1522 500020
 These offices are supported by Representatives and Distributors in many countries world-wide.
 © Dynex Semiconductor 2000 Publication No. DS4200-5 Issue No. 5.0 January 2000
TECHNICAL DOCUMENTATION – NOT FOR RESALE. PRINTED IN UNITED KINGDOM

Datasheet Annotations:

Dynex Semiconductor annotate datasheets in the top right hand corner of the front page, to indicate product status. The annotations are as follows:-

Target Information: This is the most tentative form of information and represents a very preliminary specification. No actual design work on the product has been started.

Preliminary Information: The product is in design and development. The datasheet represents the product as it is understood but details may change.

Advance Information: The product design is complete and final characterisation for volume production is well in hand.

No Annotation: The product parameters are fixed and the product is available to datasheet specification.

This publication is issued to provide information only which (unless agreed by the Company in writing) may not be used, applied or reproduced for any purpose nor form part of any order or contract nor to be regarded as a representation relating to the products or services concerned. No warranty or guarantee express or implied is made regarding the capability, performance or suitability of any product or service. The Company reserves the right to alter without prior notice the specification, design or price of any product or service. Information concerning possible methods of use is provided as a guide only and does not constitute any guarantee that such methods of use will be satisfactory in a specific piece of equipment. It is the user's responsibility to fully determine the performance and suitability of any equipment using such information and to ensure that any publication or data used is up to date and has not been superseded. These products are not suitable for use in any medical products whose failure to perform may result in significant injury or death to the user. All products and materials are sold and services provided subject to the Company's conditions of sale, which are available on request.

All brand names and product names used in this publication are trademarks, registered trademarks or trade names of their respective owners.