

## Surface Mount Low Power Step Recovery Diodes

Rev. V5

### Features

- Surface Mount Packages (SOT-23,SC-79)
- Low transition times
- SPC Process for Superior C-V Repeatability
- Tape and Reel Packaging
- Designed for Commercial Wireless Applications
- Also Offering RoHS Compliant Equivalent Parts

### Description

The MA44700 series of Step Recovery diodes is designed for use in low power multipliers with output frequencies of up to 5 GHz. These Step Recovery diodes generate harmonics by storing a charge as the diode is driven to forward conductance by the positive voltage of the input signal. When the signal reverses polarity, this charge is extracted. The Step Recovery diode will appear as a low impedance current source until all the charge is extracted, then it will “snap” to a higher impedance. This causes a voltage pulse to form in the impulse circuit of the multiplier. Step Recovery diodes make excellent high order multipliers such as comb generators. They are also useful as efficient moderate power X2-X4 multipliers.

### Applications

The MA44700 series step recovery are useful for surface mount low power applications.

### Absolute Maximum Ratings <sup>1,2</sup>

@ T<sub>A</sub>=+25 °C (Unless Otherwise Noted)

Parameter	Absolute Maximum
Operating Temperature	-65 °C to +125 °C
Storage Temperature	-65 °C to +125 °C
Reverse Voltage	30V
Forward Bias Current	50 mA
Power Dissipation	250 mW

1. Operation of this device above any one of these parameters may cause permanent damage.
2. Please refer to application note M538 for surface mounting instructions

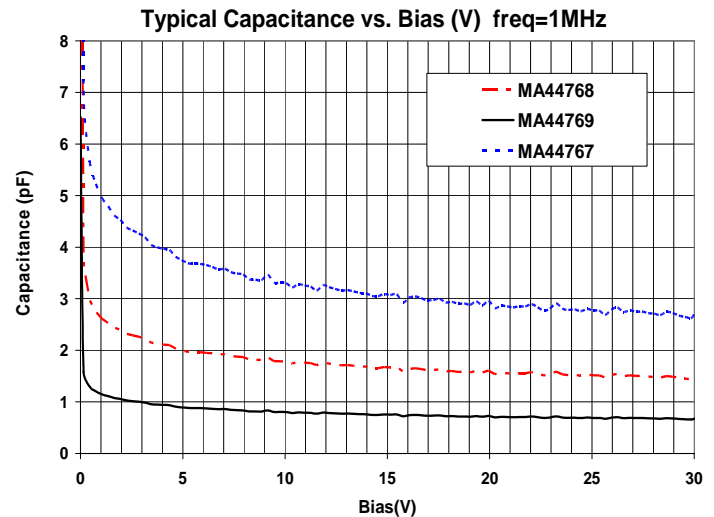

Part Number (non-RoHS) <sup>1</sup>	RoHS Compliant Part Numbers <sup>1</sup>	C <sub>T</sub> <sup>2</sup>		Reverse Voltage	Nominal Carrier	Transition Time	Nominal Input	Nominal Output
		(pF)		(V)	(nS)	(pS)	(GHz)	(GHz)
		f=1 MHz, V <sub>R</sub> =6.0 V		I <sub>r</sub> =10 uA				
		Min.	Max.	Min.	Typical	Max		
MA44767-287T	MAVR-044767-0287AT MAVR-044767-12790T	3.0	4.5	30	250-500	600	0.05-5	0.5-1.5
MA44768-287T	MAVR-044768-0287AT MAVR-044768-12790T	1.6	2.4	30	75-225	250	0.1-1	0.5-2.5
MA44769-287T	MA144769-287T MAVR-044769-12790T	0.8	1.2	30	20-50	150	0.1-1	1-5

1. The prefix defines package style, configuration and packaging information. Contact representative for complete part identification.
2. Capacitance @ 1 MHz

1

**ADVANCED:** Data Sheets contain information regarding a product M/A-COM Technology Solutions is considering for development. Performance is based on target specifications, simulated results, and/or prototype measurements. Commitment to develop is not guaranteed.

**PRELIMINARY:** Data Sheets contain information regarding a product M/A-COM Technology Solutions has under development. Performance is based on engineering tests. Specifications are typical. Mechanical outline has been fixed. Engineering samples and/or test data may be available. Commitment to produce in volume is not guaranteed.

- **North America** Tel: 800.366.2266 / Fax: 978.366.2266
  - **Europe** Tel: 44.1908.574.200 / Fax: 44.1908.574.300
  - **Asia/Pacific** Tel: 81.44.844.8296 / Fax: 81.44.844.8298
- Visit [www.macomtech.com](http://www.macomtech.com) for additional data sheets and product information.

M/A-COM Technology Solutions Inc. and its affiliates reserve the right to make changes to the product(s) or information contained herein without notice.

### Case Styles

#### SOT-23 (Case Style 287)

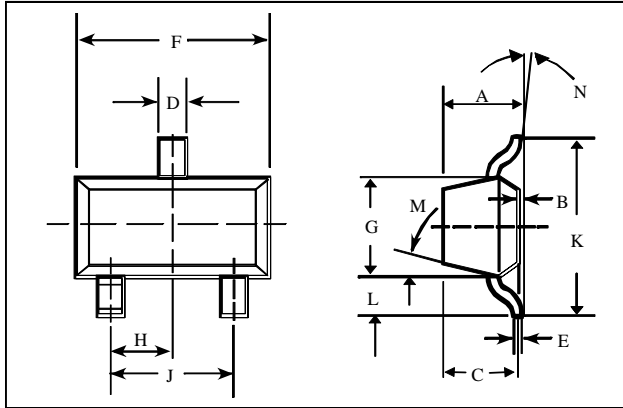

#### SOT-23 (Case Style 287)

DIM.	INCHES		MILLIMETERS	
	MIN.	MAX.	MIN.	MAX.
A	—	0.048	—	1.22
B	—	0.008	—	0.20
C	—	0.040	—	1.00
D	0.013	0.020	0.35	0.50
E	0.003	0.006	0.08	0.15
F	0.110	0.119	2.80	3.00
G	0.047	0.056	1.20	1.40
H	0.037 typical		0.95 typical	
J	0.075 typical		1.90 typical	
K	—	0.103	—	2.60
L	—	0.024	—	0.60
DIM.	GRADIENT			
M	10° max.			
N	2° . . .30°			

#### SC-79 (Case Style 1279)

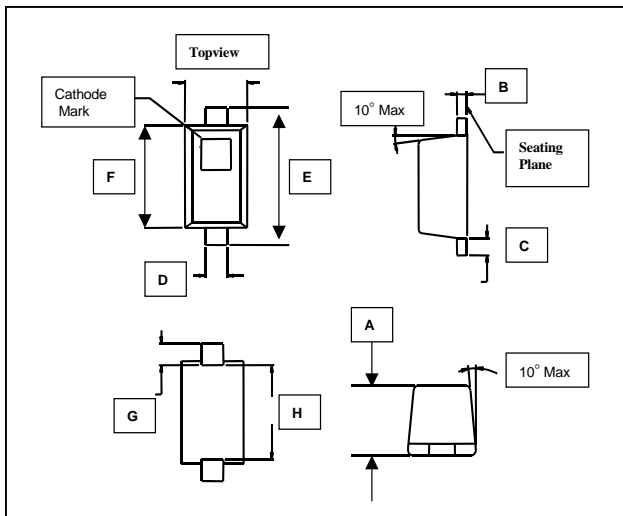

#### SC-79 (Case Style 1279)

DIM.	INCHES		MILLIMETERS	
	MIN.	MAX.	MIN.	MAX.
A	0.020	0.028	0.50	0.71
B	0.003	0.008	0.08	0.20
C	0.006	0.010	0.15	0.25
D	0.010	0.014	0.25	0.36
E	0.059	0.067	0.08	0.15
F	0.043	0.051	1.50	1.30
G	0.011	0.012	0.28	0.30
H	0.037 typical	0.043	0.94	1.09

### Mounting Information

The illustration indicates the recommended mounting pad configuration for the SOT-23 and SC-79 packages. Solder paste containing flux should be screened onto the pads to a thickness of 0.005-0.007 inches. The plastic package is placed in position, firmly adhering to the solder paste.

Permanent attachment is performed by a reflow soldering procedure during which the tab temperature does not exceed +275 °C and the body temperature does not exceed +250 °C, for standard models and +260 °C for the RoHS compliant devices.

Please refer to Application Note M538 for surface mounting instructions.

### SOT-23

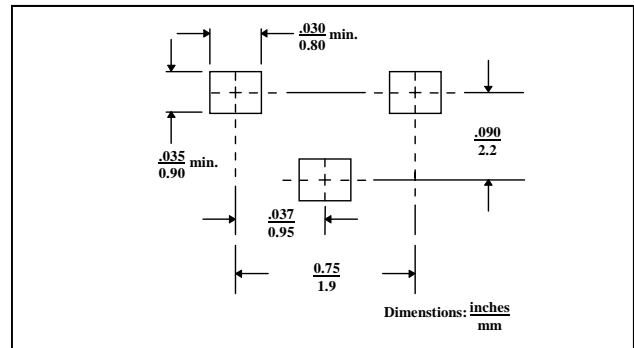

### SC-79

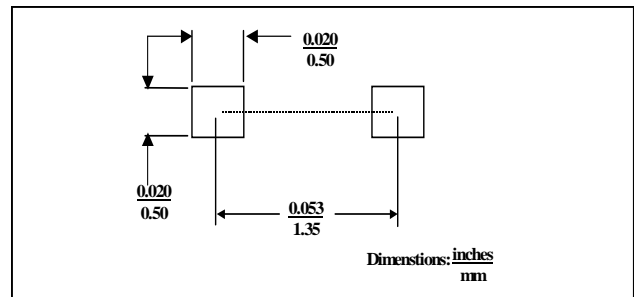

### Package Configuration

#### SOT-23 (Case Style 287)

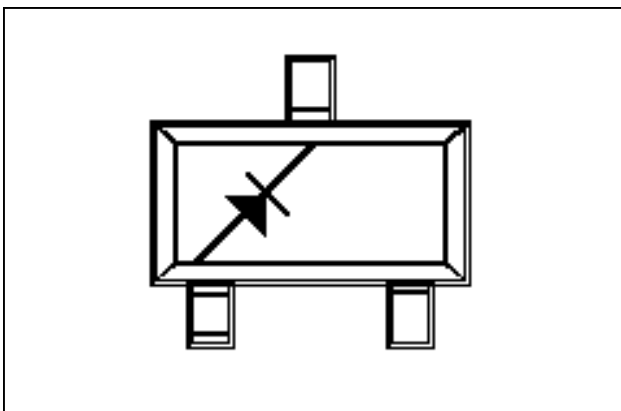

#### SC-79 (Case Style 1279)

