

### Features

- LO 7 TO 17 GHz
- RF 9 TO 15 GHz
- IF DC TO 2.5 GHz
- LO DRIVE: +10 dBm (NOMINAL)
- LOW NOISE FIGURE: 6.5 dB (TYP.)

### Description

The M67 is a double balanced mixer, designed for use in military, commercial and test equipment applications. The design utilizes Schottky ring quad diodes and broadband soft dielectric and ferrite baluns to attain excellent performance. This mixer can also be used as a phase detector and/or bi-phase modulator since the IF port is DC coupled to the diodes. The use of high temperature solder and welded assembly processes used internally makes it ideal for use in manual, semi-automated assembly. Environmental screening available to MIL-STD-883, MIL-STD-202, or MIL-DTL-28837, consult factory.

### Product Image

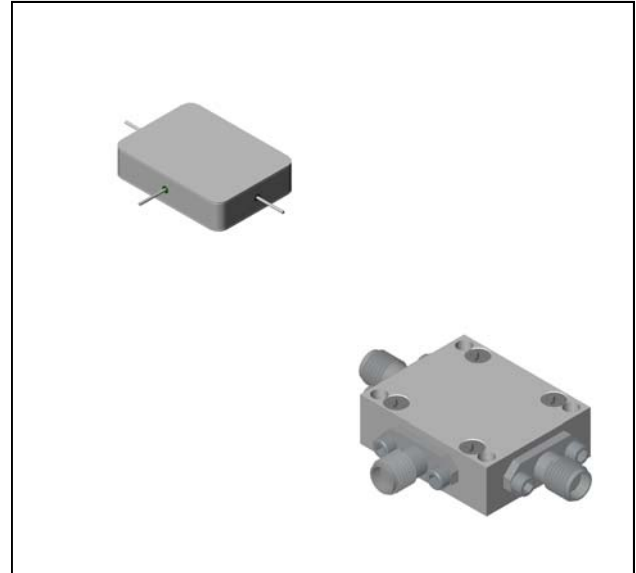

### Ordering Information

Part Number	Package
M67	Minpac
M67C	SMA Connectorized

### Electrical Specifications: $Z_0 = 50\Omega$ $Lo = +10$ dBm (Downconverter application only)

Parameter	Test Conditions	Units	Typical	Guaranteed	
				+25°C	-54° to +85°C
SSB Conversion Loss (max) & SSB Noise Figure (max)	fR = 9.5 to 13 GHz, fL = 9 to 13.5 GHz, fl = 30 to 500 GHz	dB	5.5	7.0	7.5
	fR = 9 to 15 GHz, fL = 8 to 16 GHz, fl = 30 to 1000 GHz	dB	6.5	8.5	9.0
	fR = 9 to 15 GHz, fL = 7 to 17 GHz, fl = 30 to 2000 GHz	dB	6.5	9.0	9.5
	fR = 9.5 to 13.5 GHz, fL = 7 to 16 GHz, fl = 30 to 2500 GHz	dB	6.5	9.0	9.5
Isolation, L to R (min)	fL = 7 to 15 GHz	dB	40	22	20
	fL = 15 to 17 GHz	dB	30	10	8
Isolation, L to I (min)	fL = 7 to 17 GHz	dB	25	15	13
1 dB Conversion Comp.	fL = +10 dBm	dBm	+4		
Input IP3	fR1=11.5 GHz at -6 dBm, fR2=11.5GHz at -6 dBm, fL = 12 GHz at +10 dBm	dBm	+11		

### Typical Performance Curves

Conversion Loss vs. LO Drive

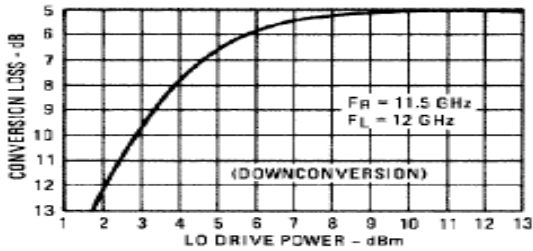

Conversion Loss vs. RF Input Power

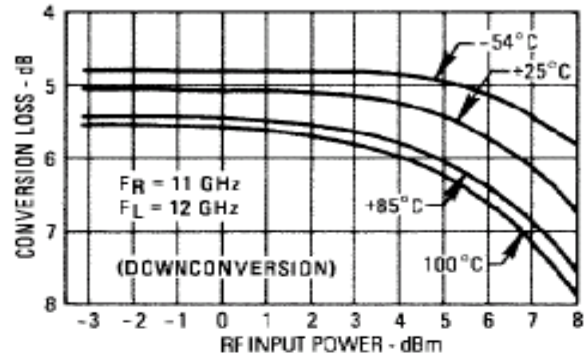

Conversion Loss vs. Frequency

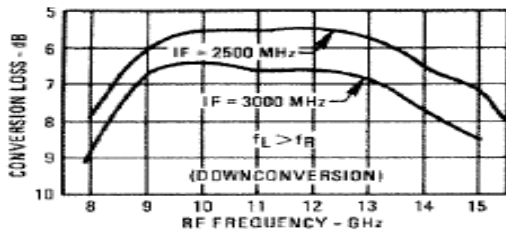
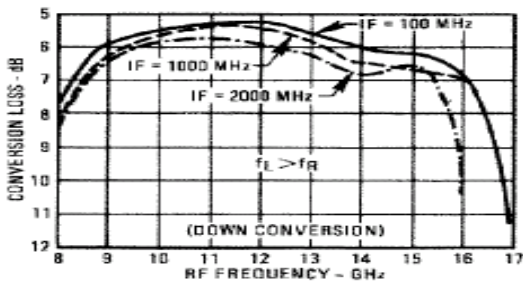

Isolation vs. Frequency

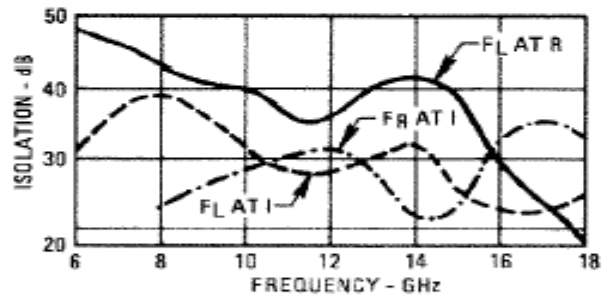

Conversion Loss vs. Output Frequency

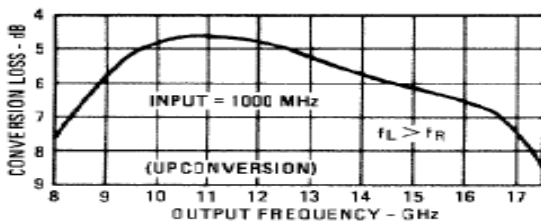

L-Port VSWR vs. Frequency

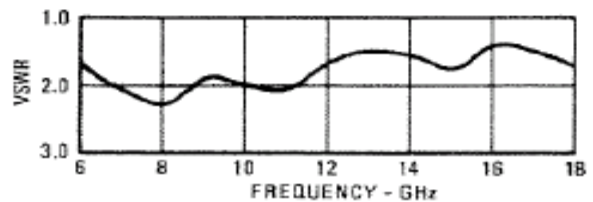

### Absolute Maximum Ratings

Parameter	Absolute Maximum
Operating Temperature	-54°C to +100°C
Storage Temperature	-65°C to +100°C
Peak Input Power	+23 dBm max @ +25°C +20 dBm max @ +100°C
Peak Input Current	50 mA DC

### R-Port VSWR vs. Frequency

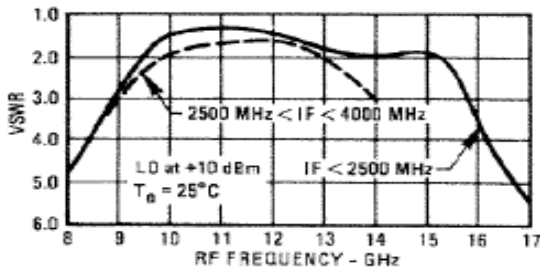

### I-Port VSWR vs. f<sub>L</sub>

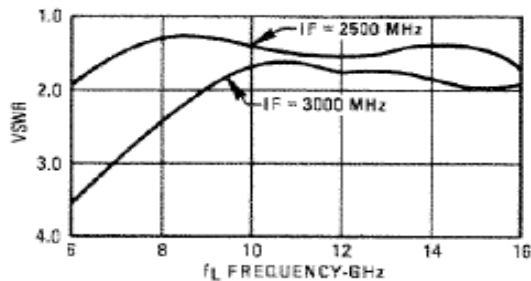
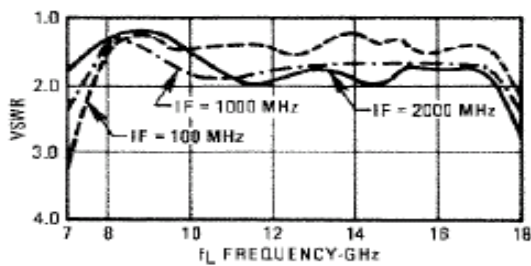

### Outline Drawing: Minpac \*

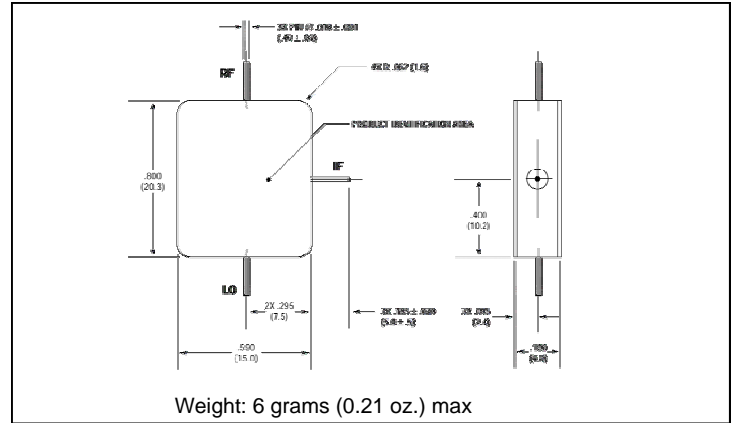

### Outline Drawing: SMA Connectorized \*

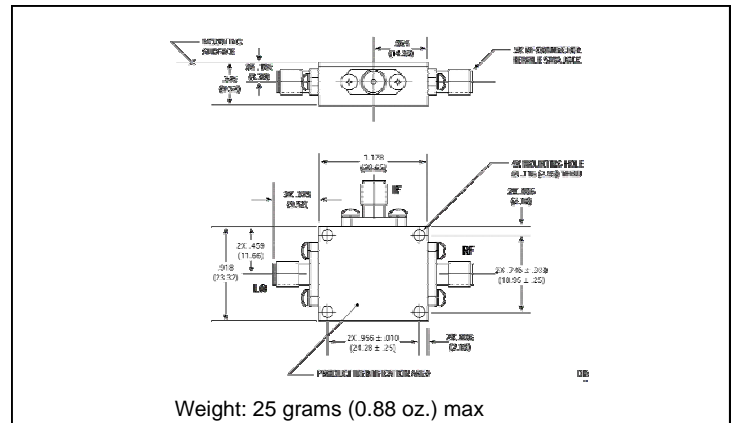

\* Dimensions are inches (millimeters) ±0.015 (0.38) unless otherwise specified.