

HC299 8 BIT PIPO SHIFT REGISTER WITH ASYNCHRONOUS CLEAR

HC323 8 BIT PIPO SHIFT REGISTER WITH SYNCHRONOUS CLEAR

- HIGH SPEED
 $f_{MAX} = 42 \text{ MHz (TYP.) AT } V_{CC} = 5\text{V}$
- LOW POWER DISSIPATION
 $I_{CC} = 4 \mu\text{A (MAX.) AT } T_A = 25^\circ\text{C}$
- HIGH NOISE IMMUNITY
 $V_{NIH} = V_{NIL} = 28\% V_{CC} \text{ (MIN.)}$
- OUTPUT DRIVE CAPABILITY
 10 LSTTL LOADS FOR QA' TO QH'
 15 LSTTL LOADS FOR QA TO QH
- SYMMETRICAL OUTPUT IMPEDANCE
 $|I_{OH}| = I_{OL} = 6 \text{ mA (MIN.) FOR } Q_A, \text{ TO } Q_H,$
 $|I_{OH}| = I_{OL} = 4 \text{ mA (MIN.) FOR } Q_A, \text{ TO } Q_H$
- BALANCED PROPAGATION DELAYS
 $t_{PLH} = t_{PHL}$
- WIDE OPERATING VOLTAGE RANGE
 $V_{CC} \text{ (OPR)} = 2 \text{ V TO } 6 \text{ V}$
- PIN AND FUNCTION COMPATIBLE
 WITH 54/74LS299

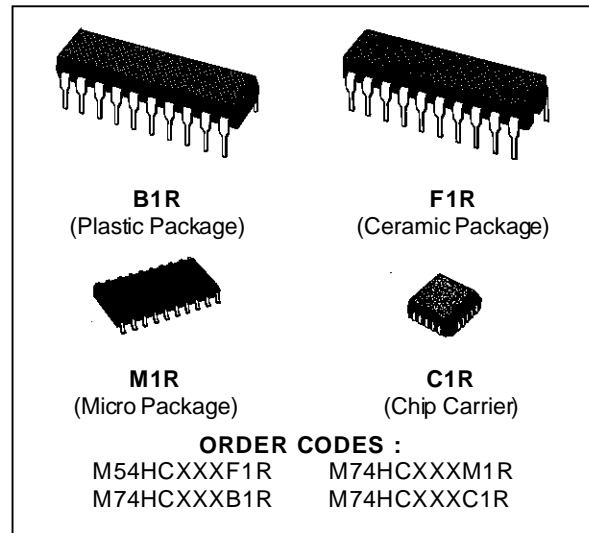

DESCRIPTION

The M54/74HC299/323 are high speed CMOS 8-BIT PIPO SHIFT REGISTERS (3-STATE) fabricated with silicon gate C²MOS technology.

They achieve the high speed operation similar to equivalent LSTTL while maintaining the CMOS low power consumption.

These devices have four modes (HOLD, SHIFT LEFT, SHIFT RIGHT and LOAD DATA). Each mode is chosen by two function select inputs (S0, S1). When one or both enable inputs, ($\overline{G1}$, $\overline{G2}$) are high, the eight input/output terminals are in the high-impedance state ; however sequential operation or clearing of the register is not affected.

Clear function on the HC299 is asynchronous to CLOCK, while the HC323 is cleared synchronous to clock.

All inputs are equipped with protection circuits against static discharge and transient excess voltage.

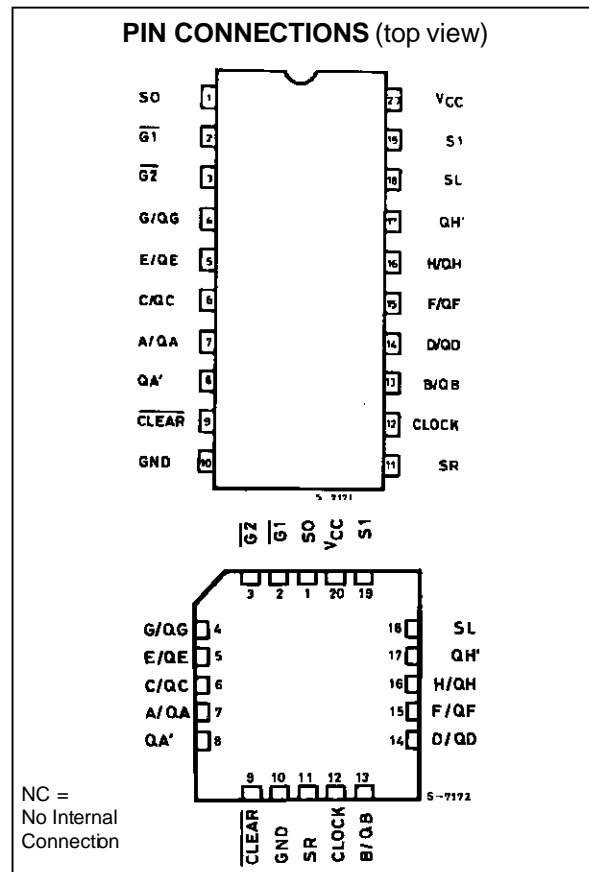

INPUT AND OUTPUT EQUIVALENT CIRCUIT

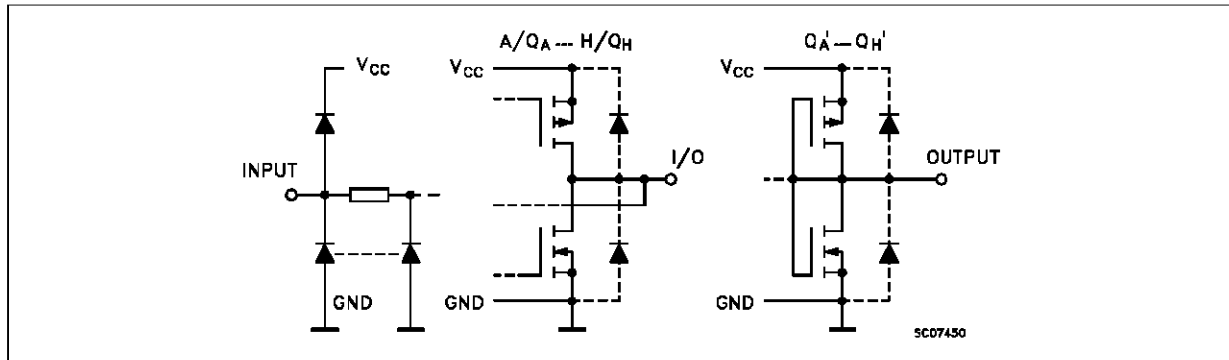

TRUTH TABLE

MODE	INPUTS					INPUTS/OUTPUTS				OUTPUTS			
	CLEAR	FUNCTION SELECTED		OUTPUT CONTROL		CLOCK		SERIAL		A/QA	H/QH	QA'	QH'
		S1	S0	G1*	G2*	(299)	(323)	SL	SR				
Z	L	H	H	X	X	X		X	X	Z	Z	L	L
CLEAR	L	L	X	L	L	X		X	X	L	L	L	L
	L	X	L	L	L	X		X	X	L	L	L	L
HOLD	H	L	L	L	L	X		X	X	QA0	QH0	QA0	QH0
SHIFT RIGHT	H	L	H	L	L			X	H	H	QGn	H	QGn
	H	L	H	L	L			X	L	L	QGn	L	QGn
SHIFT LEFT	H	H	L	L	L			H	X	QBn	H	QBn	H
	H	H	L	L	L			L	X	QBn	L	QBn	L
LOAD	H	H	H	X	X			X	X	a	h	a	h

* When one or both output controls are high, the eight, input/output terminals are in the high impedance state: however sequential operation or clearing of the register is not affected.

Z : HIGH IMPEDANCE

Qn0 : THE LEVEL OF An BEFORE THE INDICATED STEADY STATE INPUT CONDITIONS WERE ESTABLISHED.

Qnn : THE LEVEL ON Qn BEFORE THE MOST RECENT ACTIVE TRANSITION INDICATED BY OR

a, h : THE LEVEL OF THE STEADY STATE INPUTS A, H, RESPECTIVELY.

X : DON'T CARE

LOGIC DIAGRAM (HC299)

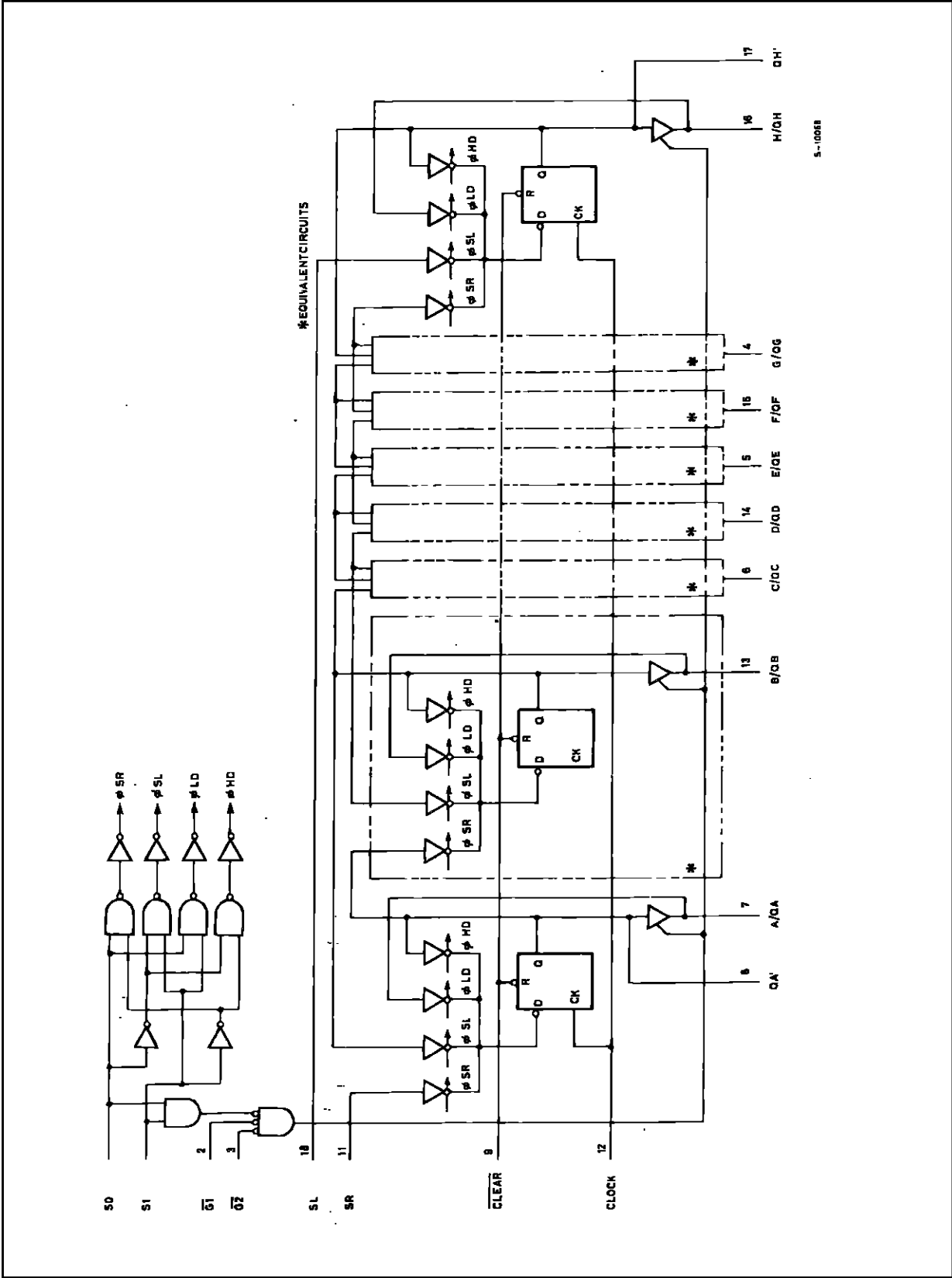

LOGIC DIAGRAM (HC323)

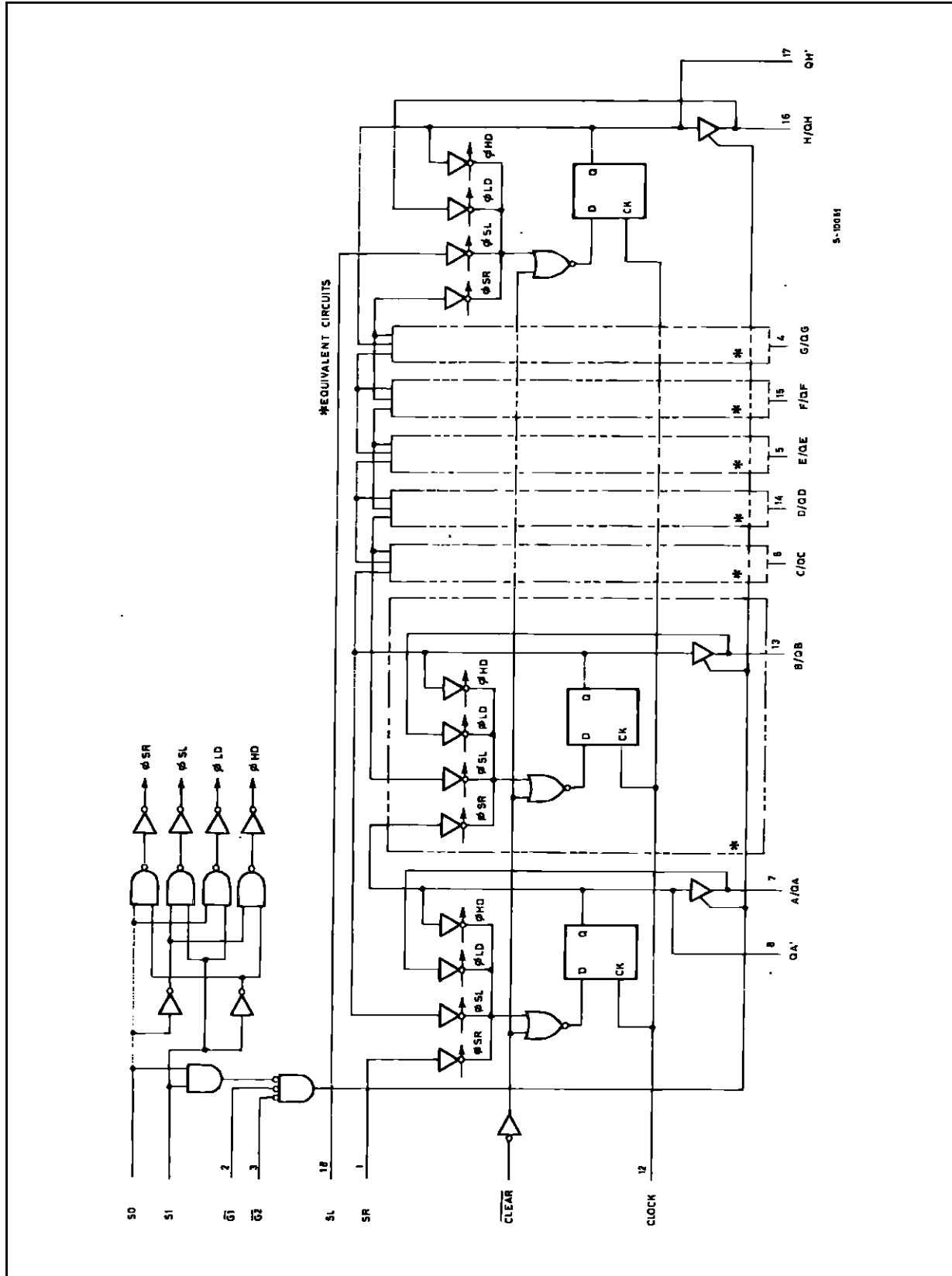

TIMING CHART

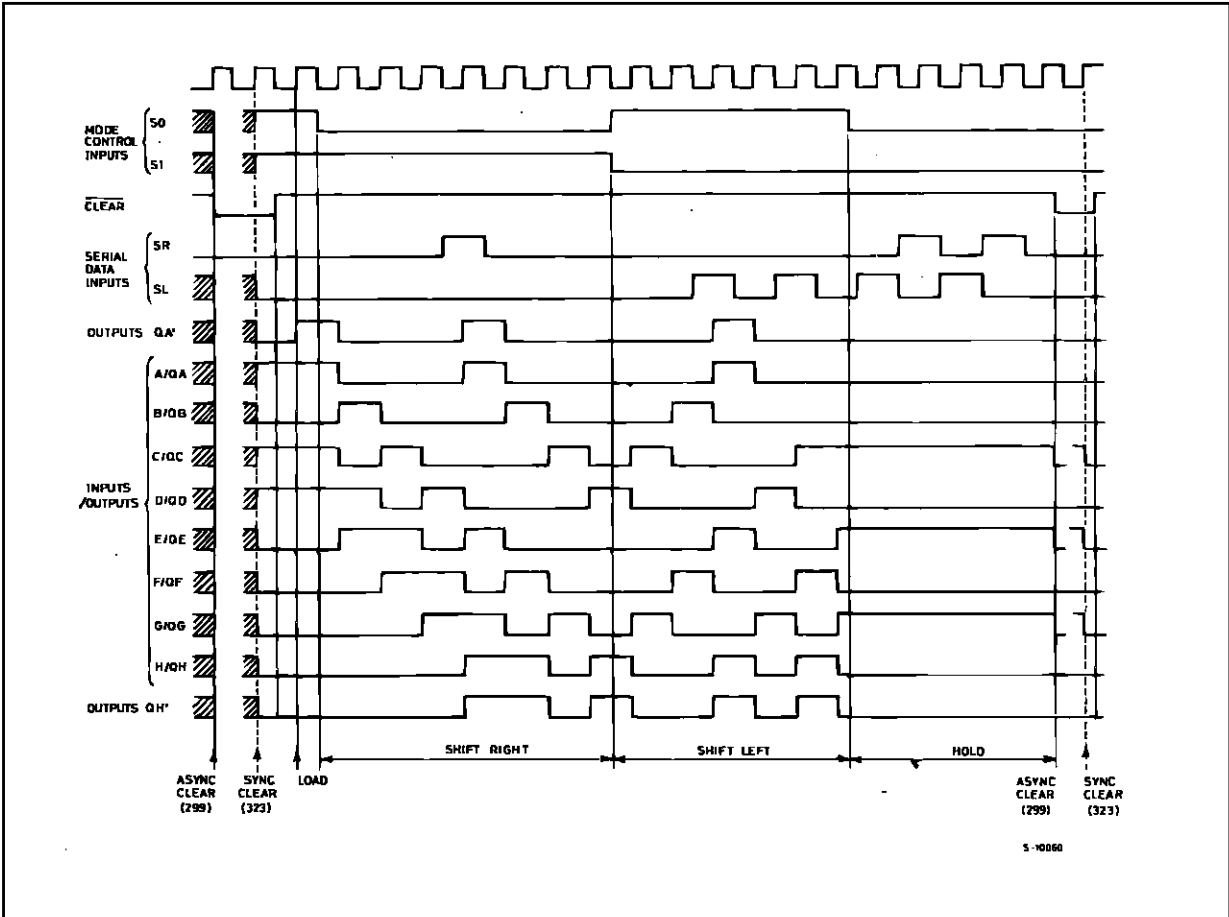

IEC LOGIC SYMBOLS

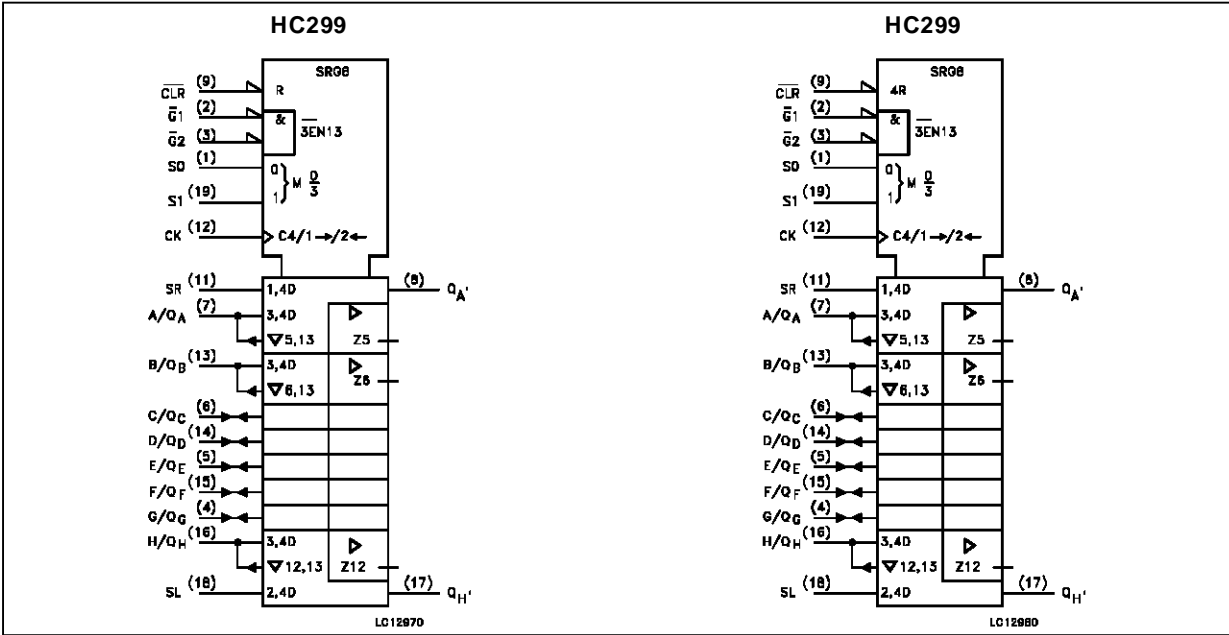

PIN DESCRIPTION

PIN No	SYMBOL	NAME AND FUNCTION
1, 19	S0, S1	Mode Select Inputs
2, 3	$\overline{G1}$, $\overline{G2}$	3 State Output Enable Inputs (Active LOW)
7, 13, 6, 14, 5, 15, 4, 16	A/QA to H/QH	Parallel Data Inputs or 3 State Parallel Outputs (Bus Driver)
8, 17	QA' to QH'	Serial Outputs (Standard Output)
9	\overline{CLEAR}	Asynchronous Master Reset Input (Active LOW)
11	SR	Serial Data Shift Right Input
12	CLOCK	Clock Input (LOW to HIGH, Edge-triggered)
18	SL	Serial Data Shift Left Input
10	GND	Ground (0V)
20	V _{CC}	Positive Supply Voltage

ABSOLUTE MAXIMUM RATINGS

Symbol	Parameter	Value	Unit
V _{CC}	Supply Voltage	-0.5 to +7	V
V _I	DC Input Voltage	-0.5 to V _{CC} + 0.5	V
V _O	DC Output Voltage	-0.5 to V _{CC} + 0.5	V
I _{IK}	DC Input Diode Current	± 20	mA
I _{OK}	DC Output Diode Current	± 20	mA
I _O	DC Output Source Sink Current Per Output Pin (QA -QH)	± 35	mA
I _O	DC Output Source Sink Current Per Output Pin (QA' -QH')	±235	mA
I _{CC} or I _{GND}	DC V _{CC} or Ground Current	± 70	mA
P _D	Power Dissipation	500 (*)	mW
T _{stg}	Storage Temperature	-65 to +150	°C
T _L	Lead Temperature (10 sec)	300	°C

Absolute Maximum Ratings are those values beyond which damage to the device may occur. Functional operation under these condition is not implied.

(*) 500 mW: ≡ 65 °C derate to 300 mW by 10mW/°C: 65 °C to 85 °C

RECOMMENDED OPERATING CONDITIONS

Symbol	Parameter	Value	Unit	
V _{CC}	Supply Voltage	2 to 6	V	
V _I	Input Voltage	0 to V _{CC}	V	
V _O	Output Voltage	0 to V _{CC}	V	
T _{op}	Operating Temperature: M54HC Series M74HC Series	-55 to +125 -40 to +85	°C °C	
t _r , t _f	Input Rise and Fall Time	V _{CC} = 2 V V _{CC} = 4.5 V V _{CC} = 6 V	0 to 1000 0 to 500 0 to 400	ns

DC SPECIFICATIONS

Symbol	Parameter	Test Conditions		Value						Unit		
		V _{CC} (V)		T _A = 25 °C 54HC and 74HC			-40 to 85 °C 74HC		-55 to 125 °C 54HC			
				Min.	Typ.	Max.	Min.	Max.	Min.		Max.	
V _{IH}	High Level Input Voltage	2.0		1.5			1.5		1.5		V	
		4.5		3.15			3.15		3.15			
		6.0		4.2			4.2		4.2			
V _{IL}	Low Level Input Voltage	2.0				0.5		0.5		0.5	V	
		4.5				1.35		1.35		1.35		
		6.0				1.8		1.8		1.8		
V _{OH}	High Level Output Voltage	2.0	V _I = V _{IH} or V _{IL}	I _O = -20 μA	1.9	2.0		1.9		1.9	V	
		4.5			4.4	4.5		4.4		4.4		
		6.0			5.9	6.0		5.9		5.9		
	QA TO QH	4.5		I _O = -6.0 mA	4.18	4.31		4.13		4.10		
		6.0			5.68	5.8		5.63		5.60		
		QA' TO QH'			4.5	I _O = -4.0 mA	4.18	4.31		4.13		
6.0	I _O = -5.2 mA		5.68	5.8			5.63		5.60			
V _{OL}		Low Level Output Voltage	2.0	V _I = V _{IH} or V _{IL}	I _O = 20 μA		0.0	0.1		0.1		V
	4.5					0.0	0.1		0.1		0.1	
	6.0					0.0	0.1		0.1		0.1	
	QA TO QH	4.5	I _O = 6.0 mA			0.17	0.26		0.33		0.40	
		6.0				0.18	0.26		0.33		0.40	
		QA' TO QH'			4.5	I _O = 4.0 mA		0.17	0.26		0.33	
6.0	I _O = 5.2 mA			0.18	0.26			0.33		0.40		
I _I		Input Leakage Current	6.0	V _I = V _{CC} or GND			±0.1		±1		±1	μA
I _{OZ}	3 State Output Off-state Current	6.0	V _I = V _{IH} or V _{IL} V _O = V _{CC} or GND			±0.5		±5		±10	μA	
I _{CC}	Quiescent Supply Current	6.0	V _I = V _{CC} or GND			4		40		80	μA	

AC ELECTRICAL CHARACTERISTICS (C_L = 50 pF, Input t_r = t_f = 6 ns)

Symbol	Parameter	Test Conditions		Value						Unit		
		V _{CC} (V)	C _L (pF)	T _A = 25 °C 54HC and 74HC			-40 to 85 °C 74HC		-55 to 125 °C 54HC			
				Min.	Typ.	Max.	Min.	Max.	Min.		Max.	
t _{TLH} t _{THL}	Output Transition Time (QA, QH)	2.0	50		25	60		75		90	ns	
		4.5			7	12		15		18		
		6.0			6	10		13		15		
t _{TLH} t _{THL}	Output Transition Time (QA', QH')	2.0	50		30	75		95		110	ns	
		4.5			8	15		19		22		
		6.0			7	13		16		19		
t _{PLH} t _{PHL}	Propagation Delay Time (CK - QA', QH')	2.0	50		85	170		215		255	ns	
		4.5			23	34		43		51		
		6.0			18	29		37		43		
t _{PHL}	Propagation Delay Time (CLR - QA', QH')	2.0	50	for HC299		85	175		220		265	ns
		4.5				24	35		44		53	
		6.0				18	30		37		45	

M54/M74HC299/323

AC ELECTRICAL CHARACTERISTICS (C_L = 50 pF, Input t_r = t_f = 6 ns)

Symbol	Parameter	Test Conditions			Value						Unit	
		V _{CC} (V)	C _L (pF)		T _A = 25 °C 54HC and 74HC			-40 to 85 °C 74HC		-55 to 125 °C 54HC		
					Min.	Typ.	Max.	Min.	Max.	Min.		Max.
t _{PLH} t _{PHL}	Propagation Delay Time (CK - QA, QH)	2.0	50			80	160		200		240	ns
		4.5				21	32		40		48	
		6.0				17	27		34		41	
		2.0	150			100	200		250		300	ns
		4.5				26	40		50		60	
		6.0				21	34		43		51	
t _{PHL}	Propagation Delay Time (CLR - QA, QH)	2.0	50	for HC323		85	190		240		285	ns
		4.5				24	38		48		57	
		6.0				18	32		41		48	
		2.0	150	for HC323		105	230		290		345	ns
		4.5				29	46		58		69	
		6.0				22	39		49		59	
t _{PZL} t _{PZH}	3 State Output Enable Time	2.0	50	R _L = 1 KΩ		60	130		165		195	ns
		4.5				17	26		33		39	
		6.0				13	22		28		33	
		2.0	150	R _L = 1 KΩ		78	170		15		255	ns
		4.5				23	34		43		51	
		6.0				17	29		37		43	
t _{PLZ} t _{PHZ}	3 State Output Disable Time	2.0	50	R _L = 1 KΩ		54	150		190		225	ns
		4.5				19	30		38		45	
		6.0				16	26		32		38	
f _{MAX}	Maximum Clock Frequency	2.0	50			6	12		4.8		4	ns
		4.5				30	58		24		20	
		6.0				35	80		28		24	
t _{W(L)} t _{W(H)}	Minimum Pulse Width (CLOCK)	2.0	50				75		95		110	ns
		4.5					15		19		22	
		6.0					13		16		19	
t _{W(L)}	Minimum Pulse Width (CLEAR)	2.0	50	for HC299			75		95		110	ns
		4.5					15		19		22	
		6.0					13		16		19	
t _s	Minimum Set-up Time (S0, S1) (SL, SR, A H) (CLEAR for 323)	2.0	50				100		125		150	ns
		4.5					20		25		30	
		6.0					17		21		26	
t _h	Minimum Hold Time (S0, S1) (SL, SR, A H) (CLEAR for 323)	2.0	50				0		0		0	ns
		4.5					0		0		0	
		6.0					0		0		0	
t _{REM}	Minimum Removal Time (CLEAR)	2.0	50	for HC299			50		65		75	ns
		4.5					10		13		15	
		6.0					9		11		13	
C _{IN}	Input Capacitance					5	10		10	10	pF	
C _{PD} (*)	Power Dissipation Capacitance					170					pF	

(*) C_{PD} is defined as the value of the IC's internal equivalent capacitance which is calculated from the operating current consumption without load. (Refer to Test Circuit). Average operating current can be obtained by the following equation. I_{CC(OPR)} = C_{PD} • V_{CC} • f_{IN} + I_{CC}

SWITCHING CHARACTERISTICS TEST WAVEFORM

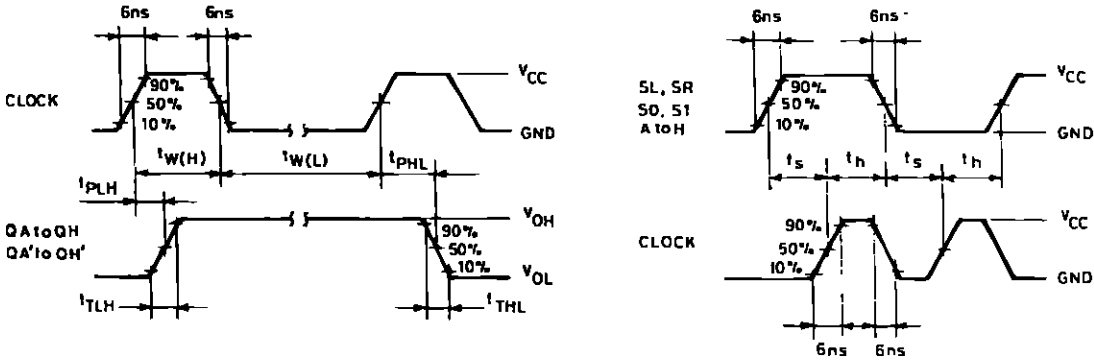

S-10062

HC299

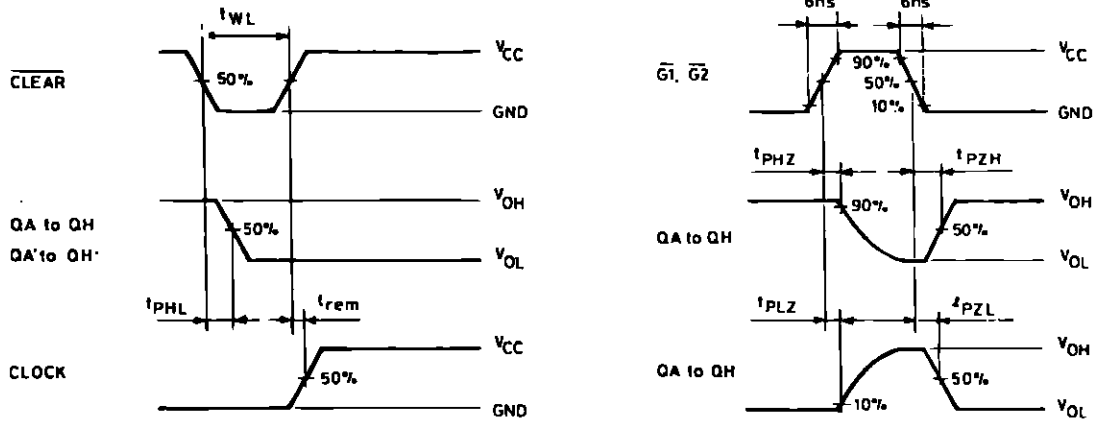

HC323

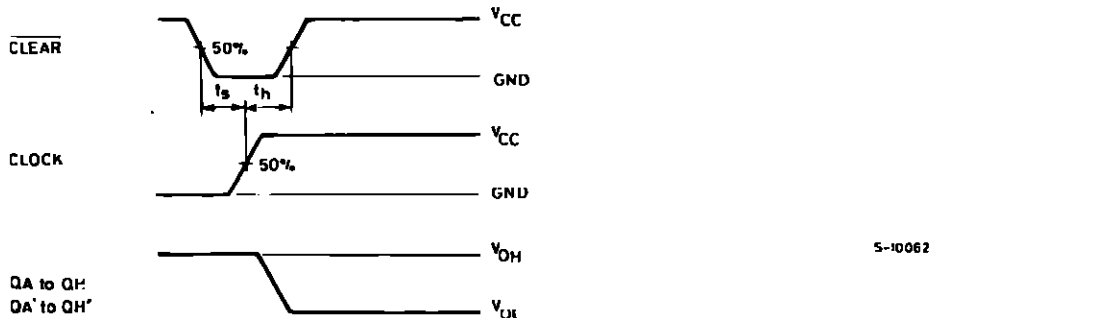

S-10062

TEST CIRCUIT I_{CC} (Opr.)

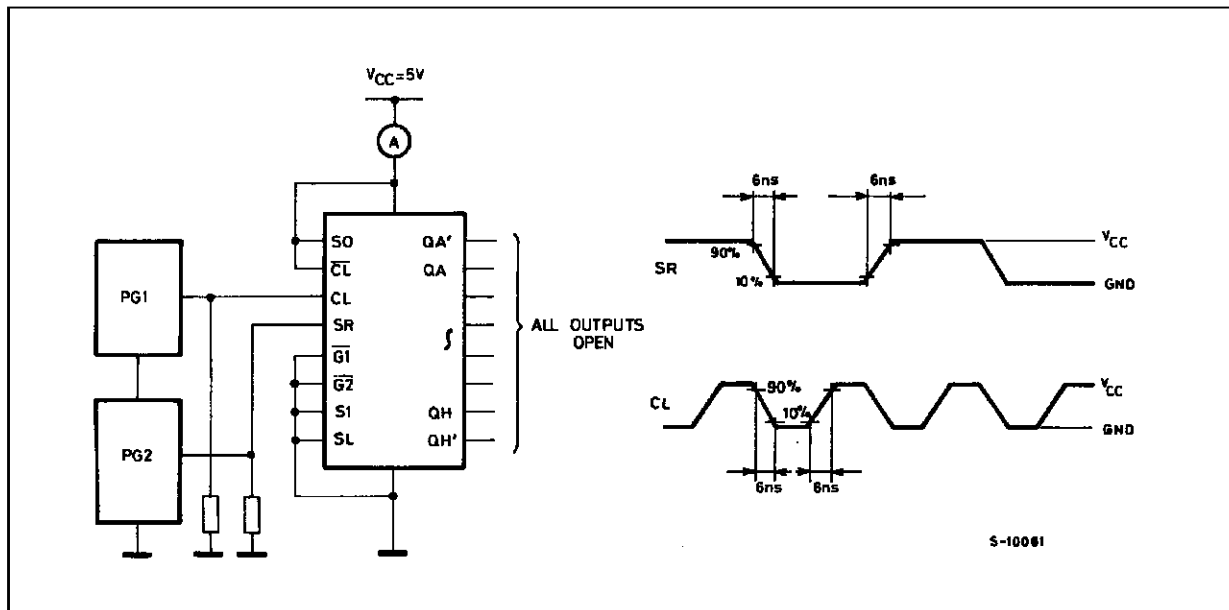

Plastic DIP20 (0.25) MECHANICAL DATA

DIM.	mm			inch		
	MIN.	TYP.	MAX.	MIN.	TYP.	MAX.
a1	0.254			0.010		
B	1.39		1.65	0.055		0.065
b		0.45			0.018	
b1		0.25			0.010	
D			25.4			1.000
E		8.5			0.335	
e		2.54			0.100	
e3		22.86			0.900	
F			7.1			0.280
I			3.93			0.155
L		3.3			0.130	
Z			1.34			0.053

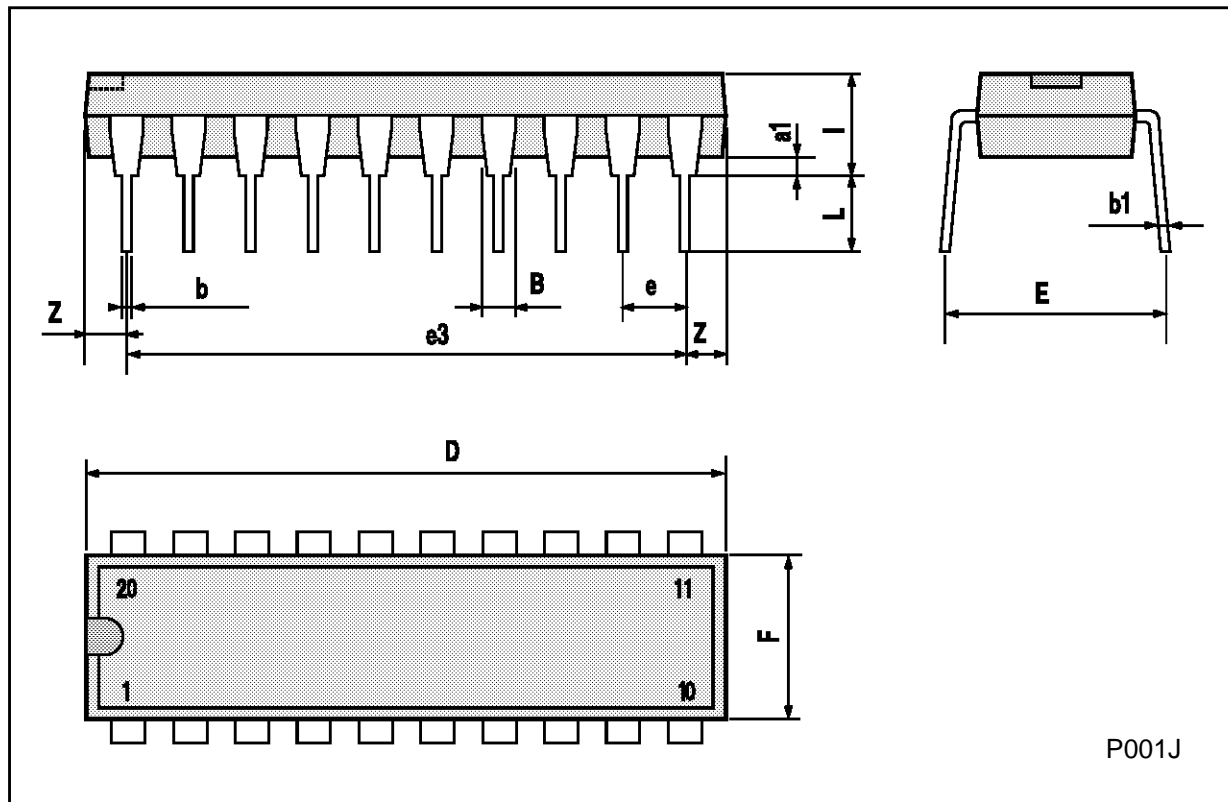

P001J

Ceramic DIP20 MECHANICAL DATA

DIM.	mm			inch		
	MIN.	TYP.	MAX.	MIN.	TYP.	MAX.
A			25			0.984
B			7.8			0.307
D		3.3			0.130	
E	0.5		1.78	0.020		0.070
e3		22.86			0.900	
F	2.29		2.79	0.090		0.110
G	0.4		0.55	0.016		0.022
I	1.27		1.52	0.050		0.060
L	0.22		0.31	0.009		0.012
M	0.51		1.27	0.020		0.050
N1	4° (min.), 15° (max.)					
P	7.9		8.13	0.311		0.320
Q			5.71			0.225

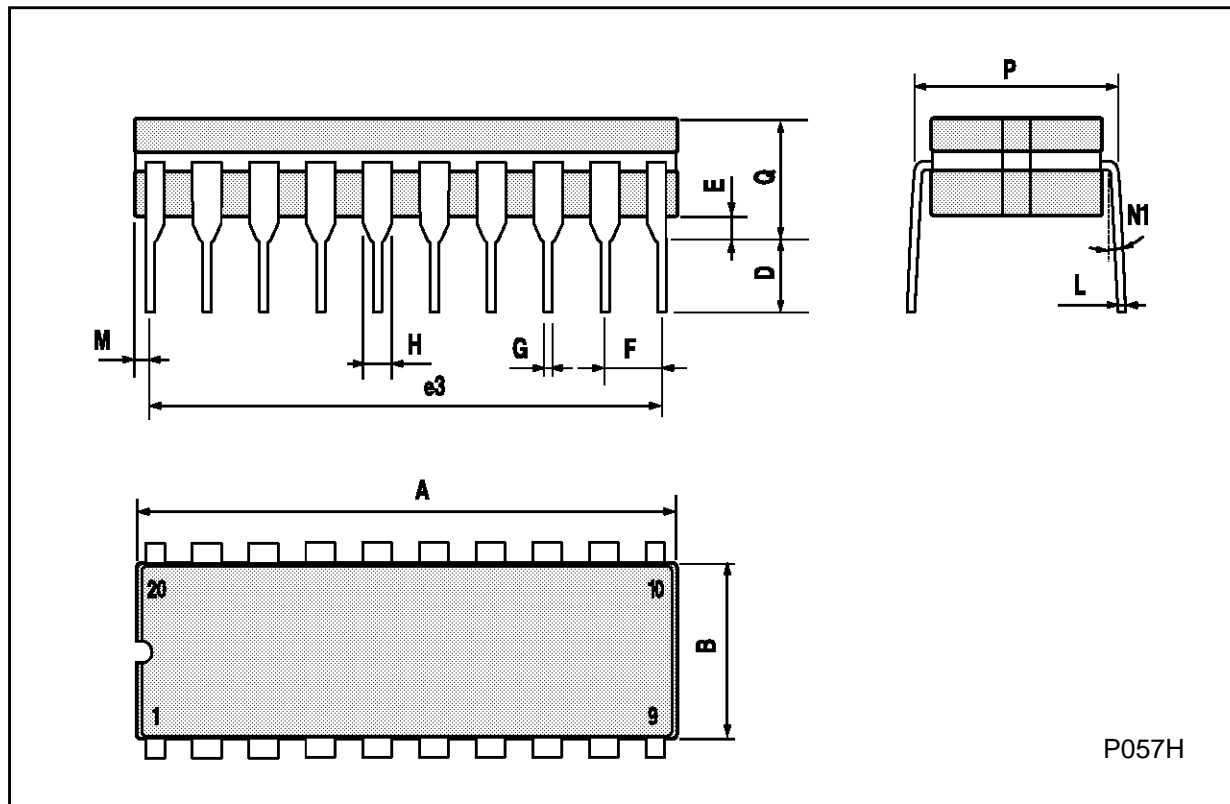

SO20 MECHANICAL DATA

DIM.	mm			inch		
	MIN.	TYP.	MAX.	MIN.	TYP.	MAX.
A			2.65			0.104
a1	0.10		0.20	0.004		0.007
a2			2.45			0.096
b	0.35		0.49	0.013		0.019
b1	0.23		0.32	0.009		0.012
C		0.50			0.020	
c1	45° (typ.)					
D	12.60		13.00	0.496		0.512
E	10.00		10.65	0.393		0.419
e		1.27			0.050	
e3		11.43			0.450	
F	7.40		7.60	0.291		0.299
L	0.50		1.27	0.19		0.050
M			0.75			0.029
S	8° (max.)					

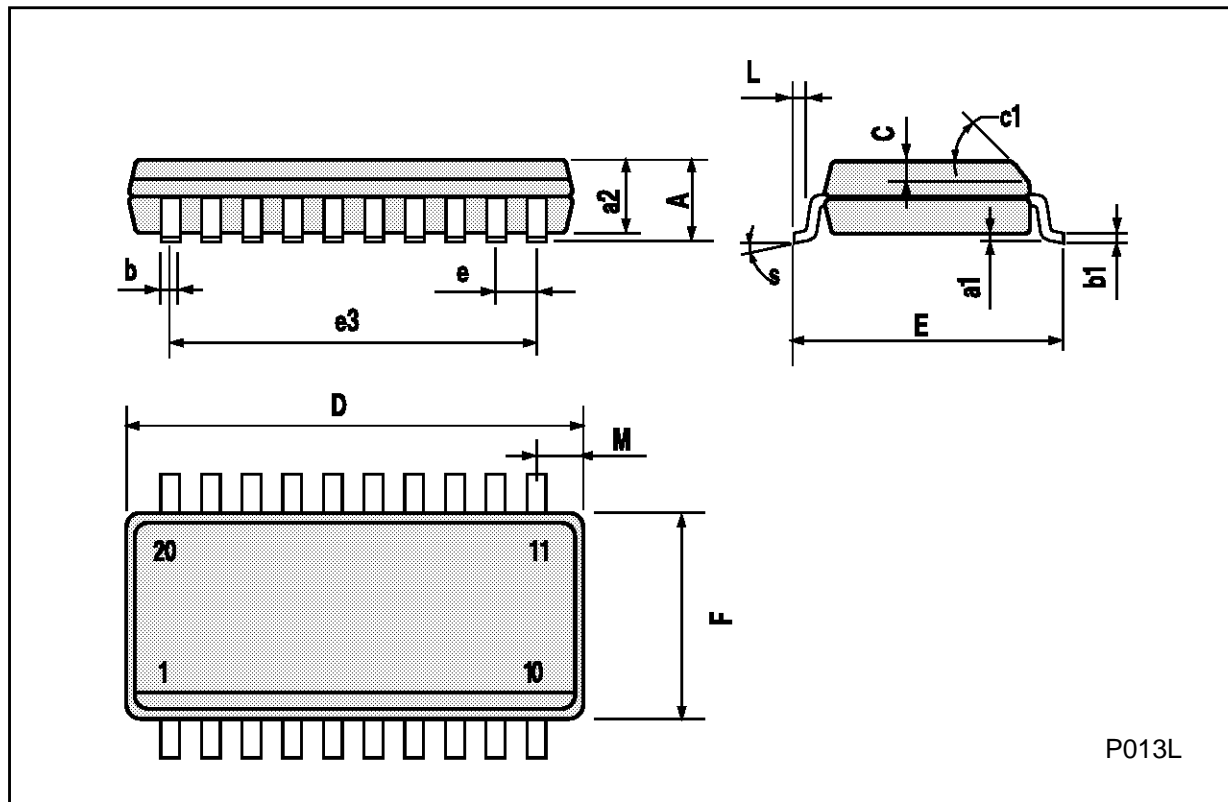

P013L

PLCC20 MECHANICAL DATA

DIM.	mm			inch		
	MIN.	TYP.	MAX.	MIN.	TYP.	MAX.
A	9.78		10.03	0.385		0.395
B	8.89		9.04	0.350		0.356
D	4.2		4.57	0.165		0.180
d1		2.54			0.100	
d2		0.56			0.022	
E	7.37		8.38	0.290		0.330
e		1.27			0.050	
e3		5.08			0.200	
F		0.38			0.015	
G			0.101			0.004
M		1.27			0.050	
M1		1.14			0.045	



Information furnished is believed to be accurate and reliable. However, SGS-THOMSON Microelectronics assumes no responsibility for the consequences of use of such information nor for any infringement of patents or other rights of third parties which may result from its use. No license is granted by implication or otherwise under any patent or patent rights of SGS-THOMSON Microelectronics. Specifications mentioned in this publication are subject to change without notice. This publication supersedes and replaces all information previously supplied. SGS-THOMSON Microelectronics products are not authorized for use as critical components in life support devices or systems without express written approval of SGS-THOMSON Microelectronics.

© 1994 SGS-THOMSON Microelectronics - All Rights Reserved

SGS-THOMSON Microelectronics GROUP OF COMPANIES

Australia - Brazil - France - Germany - Hong Kong - Italy - Japan - Korea - Malaysia - Malta - Morocco - The Netherlands -
Singapore - Spain - Sweden - Switzerland - Taiwan - Thailand - United Kingdom - U.S.A