



LD3870

LINEAR INTEGRATED CIRCUIT

LOW DROPOUT VOLTAGE REGULATOR

DESCRIPTION

The UTC **LD3870** is low dropout voltage regulator designed for cellular phone application.

FEATURES

- * High Ripple Rejection: $56\text{dB} \leq \text{RR}(\text{DC} < f < 60\text{kHz})$
66dB typ. (f=100Hz)
60dB typ. (f=1kHz)
- * Output Noise Voltage: $e_N = 30\text{mV}$, $C_p = 0.01\mu\text{F}$
- * Output Current: $I_{O(\text{MAX})} = 150\text{mA}$
- * High Precision Output: $V_O \pm 2\%$
- * Low Dropout Voltage: $V_D = 0.12\text{V}$ typ.
($I_O = 60\text{mA}, V_O \geq 1.8\text{V}$)
- * Input Voltage range: $+2 \sim +14\text{V}$ ($V_O = 1.5\text{V}$ Version)
- * ON/OFF Control: Active High
- * Output capacitor with 4.7uF ceramic capacitor
- * Internal Short Circuit Current Limit
- * Internal Thermal Overload Protection

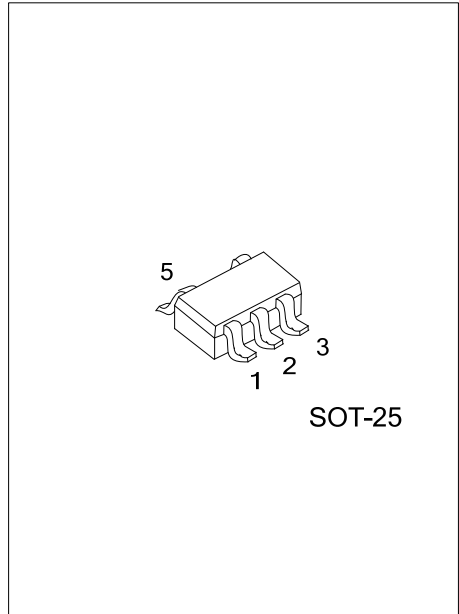

ORDERING INFORMATION

Ordering Number		Package	Packing
Lead Free	Halogen Free		
LD3870L-xx-AF5-R	LD3870G-xx-AF5-R	SOT-25	Tape Reel

<p>LD3870G-xx-AF5-R</p> <p>(1) Packing Type</p> <p>(2) Package Type</p> <p>(3) Output Voltage Code</p> <p>(4) Green Package</p>	<p>(1) R: Tape Reel</p> <p>(2) AF5: SOT-25</p> <p>(3) xx: refer to Marking Information</p> <p>(4) G: Halogen Free and Lead Free, L: Lead Free</p>
---	---

MARKING INFORMATION

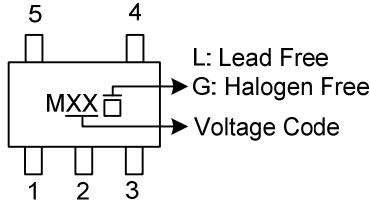
PACKAGE	VOLTAGE CODE	MARKING
SOT-25	15:1.5V	 <p>5 4 MXX 1 2 3 L: Lead Free G: Halogen Free Voltage Code</p>
	18:1.8V	
	25:2.5V	
	27:2.7V	
	30:3.0V	
	33:3.3V	
	50:5.0V	

PIN CONFIGURATION

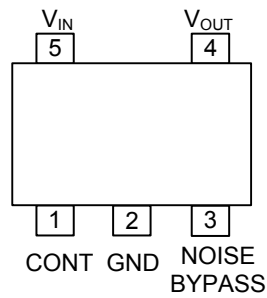

BLOCK DIAGRAM

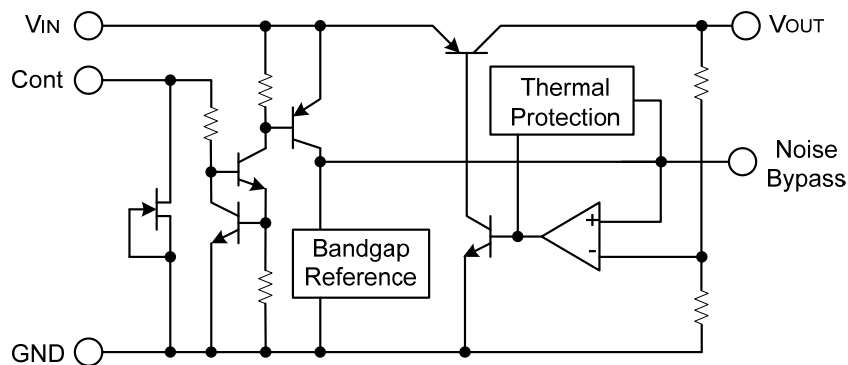

■ ABSOLUTE MAXIMUM RATINGS (T_A=25°C, unless otherwise specified)

PARAMETER	SYMBOL	RATINGS	UNIT
Input Voltage	V _{IN}	+14	V
Control Voltage	V _{CONT}	+14(Note 2)	V
Power Dissipation	P _D	300	mW
Operating Temperature	T _{OPR}	-40 ~ +85	°C
Storage Temperature	T _{STG}	-40 ~ +125	°C

Note 1: Absolute maximum ratings are those values beyond which the device could be permanently damaged.

Absolute maximum ratings are stress ratings only and functional device operation is not implied.

2. When input voltage is less than +14V, the absolute maximum control voltage is equal to the input voltage.

■ ELECTRICAL CHARACTERISTICS

(V_{IN}=V_{OUT}+1V, C_{IN}=0.1μF, C_{OUT}=4.7μF, C_p=0.01μF, T_A=25°C)

PARAMETER	SYMBOL	TEST CONDITIONS	MIN	TYP	MAX	UNIT
Output Voltage	V _{OUT}	I _{OUT} =30mA	-2%		+2%	V
Quiescent Current	I _Q	I _{OUT} =0mA, expect I _{CONT}		200	300	μA
Quiescent Current At Control OFF	I _{Q(OFF)}	V _{CONT} =0V			5	μA
Output Current	I _{OUT}	V _{OUT} =0.3V	150	200		mA
Line Regulation	$\Delta V_{OUT}/\Delta V_{IN}$	V _{IN} =V _{OUT} +1V ~ 14V, I _{OUT} =1mA			0.15	%/V
Load Regulation	$\Delta V_{OUT}/\Delta I_{OUT}$	I _{OUT} =0 ~ 100mA			0.03	%/mA
Dropout Voltage	V _D	I _{OUT} =60mA		0.12	0.2	V
Ripple Rejection	RR	e _{IN} =200mVrms, f=1kHz, I _{OUT} =10mA, V _{IN} =V _{OUT} +2V, V _{OUT} =3V Version		60		dB
Average Temperature Coefficient of Output Voltage	$\Delta V_{OUT}/\Delta T_A$	T _A =0~85°C, I _{OUT} =10mA, V _{OUT} =3V Version		0.2		mV/°C
Output Noise Voltage	e _N	f=10Hz ~ 80kHz, I _{OUT} =10mA, V _{OUT} =3V Version		30		μVrms
Control Voltage	ON	V _{CONT(ON)}	1.6			V
	OFF	V _{CONT(OFF)}			0.6	V

Note: The above specification is a common specification for all output voltages. Therefore, it may be different from the individual specification for a specific output voltage.

■ TEST CIRCUIT

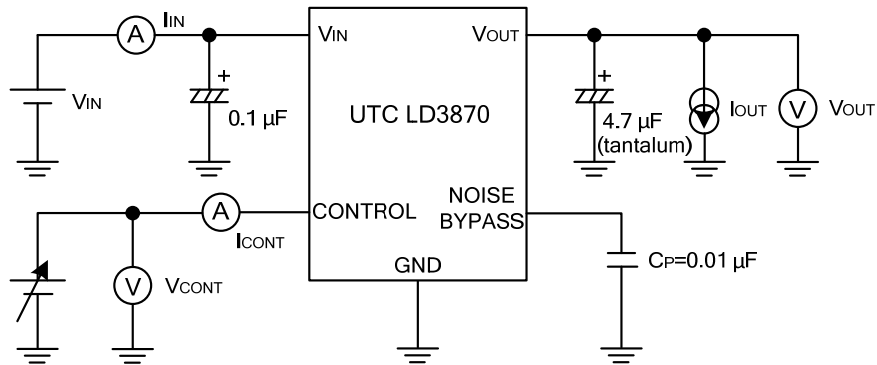

■ TYPICAL APPLICATION

For ON/OFF Control is not required:

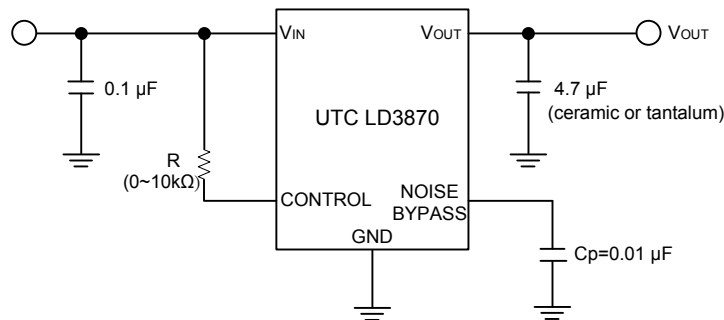

Connect control terminal to V_{IN} terminal

The quiescent current can be reduced by using a resistance "R". Instead, it increases the minimum operating voltage. For further information, please refer to Figure "Output Voltage vs. Control Voltage".

For In use of ON/OFF CONTROL:

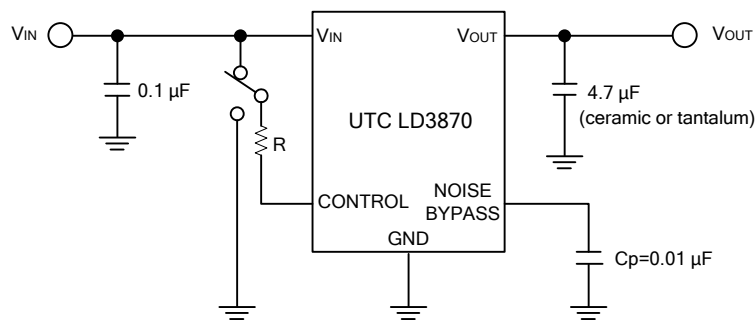

State of control terminal:

- * "H" → Output is enables.
- * "L" or "open" → Output is disabled.
- * Noise bypass Capacitance C_p
 - Noise bypass capacitance C_p reduces noise generated by hand-gap reference circuit.
 - Noise level and ripple rejection will be improved when larger C_p is used.
 - Use of smaller C_p value may cause oscillation.
 - Use the C_p value of 0.01 μ F greater to avoid the problem.

UTC assumes no responsibility for equipment failures that result from using products at values that exceed, even momentarily, rated values (such as maximum ratings, operating condition ranges, or other parameters) listed in products specifications of any and all UTC products described or contained herein. UTC products are not designed for use in life support appliances, devices or systems where malfunction of these products can be reasonably expected to result in personal injury. Reproduction in whole or in part is prohibited without the prior written consent of the copyright owner. UTC reserves the right to make changes to information published in this document, including without limitation specifications and product descriptions, at any time and without notice. This document supersedes and replaces all information supplied prior to the publication hereof.