



**LD3117**

**LINEAR INTEGRATED CIRCUIT**

**500mA LOW DROPOUT LINEAR VOLTAGE REGULATORS**

■ **DESCRIPTION**

The UTC **LD3117** are 500mA fixed output voltage low dropout linear regulators. Wide range of available output voltage fits most of applications. Built-in output current-limiting most thermal-limiting provide maximal protection against any fault conditions.

■ **FEATURES**

- \*Guaranteed 500mA output current
- \*Input voltage range up to 20V
- \*Extremely tight load regulation
- \*Fast transient response
- \*Current-limiting and Thermal-limiting
- \*Three-terminal adjustable or fixed 1.5V, 1.8V, 2.2V, 2.5V, 2.7V, 2.8V, 2.9V, 3.0V, 3.3V, 3.5V, 3.6V, 3.7V, 4.7V, 5.0V

■ **ORDERING INFORMATION**

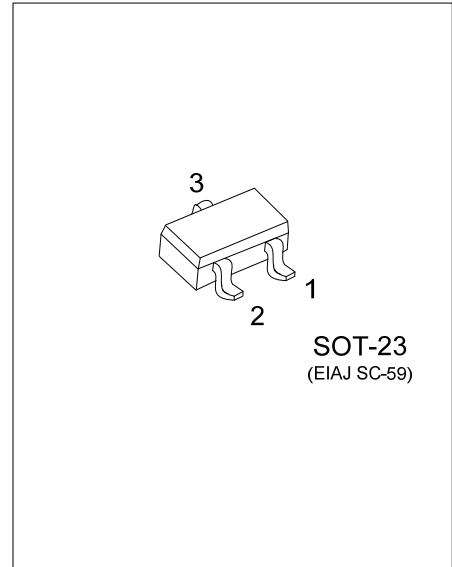

Ordering Number		Package	① Pin Assignment	Packing
Lead Free	Halogen Free			
LD3117L-xx-AE3-①-R	LD3117G-xx-AE3-①-R	SOT-23	A: GOI B: OGI C: GIO D: IGO	R: Tape Reel

Note: 1. Pin assignment: I:  $V_{IN}$  (Positive Power Input) O:  $V_{OUT}$  (Output) G: GND (Ground/Adjustable)  
2. xx: Output Voltage, refer to Marking Information.

<p>LD3117G-xx-AE3-①-R</p>	<p>(1)Packing Type</p> <p>(2)Pin Assignment</p> <p>(3)Package Type</p> <p>(4)Output Voltage Code</p> <p>(5)Green Package</p>	<p>(1) R: Tape Reel</p> <p>(2) refer to Pin Assignment</p> <p>(3) AE3: SOT-23</p> <p>(4) xx: refer to Marking Information</p> <p>(5) G: Halogen Free and Lead Free, L: Lead Free</p>
---------------------------	--	--

### MARKING INFORMATION

PACKAGE	VOLTAGE CODE	PIN CODE	PIN 1	PIN 2	PIN 3	MARKING
SOT-23	15:1.5V	A	G	O	I	
	18:1.8V					
	22:2.2V					
	25:2.5V					
	27:2.7V	B	O	G	I	
	28:2.8V					
	29:2.9V					
	30:3.0V	C	G	I	O	
	33:3.3V					
	35:3.5V					
	36:3.6V					
	37:3.7V	D	I	G	O	
	47:4.7V					
	50:5.0V					
AD:ADJ						

### ■ ABSOLUTE MAXIMUM RATINGS

PARAMETER	SYMBOL	RATINGS	UNIT
Input Voltage $V_{IN}$	$V_{IN}$	-0.3 ~ +20	V
Power Dissipation	$P_D$	295	mW
Operating Temperature	$T_{OPR}$	-40 ~ +85	°C
Storage Temperature	$T_{STG}$	-65 ~ +150	°C

Note: Absolute maximum ratings are those values beyond which the device could be permanently damaged. Absolute maximum ratings are stress ratings only and functional device operation is not implied.

### ■ THERMAL DATA

PARAMETER	SYMBOL	RATINGS	UNIT
Junction to Ambient	$\theta_{JA}$	335	°C/W

### ■ ELECTRICAL CHARACTERISTICS ( $T_A=25^\circ\text{C}$ , $C_{IN}=1\mu\text{F}$ , $C_{OUT}=10\mu\text{F}$ , unless otherwise specified)

#### For LD3117-1.5V, 1.8V, 2.2V, 2.5V, 2.7V, 2.8V, 2.9V, 3.0V

PARAMETER	SYMBOL	TEST CONDITIONS	MIN	TYP	MAX	UNIT
Output Voltage	$V_{OUT}$	$I_L=2\text{mA}$ , $V_{IN}-V_{OUT}=1.4\text{V}$	1.47	1.50	1.53	V
			1.77	1.80	1.83	V
			2.16	2.20	2.24	V
			2.45	2.50	2.55	V
			2.65	2.70	2.75	V
			2.74	2.80	2.86	V
			2.84	2.90	2.96	V
			2.94	3.00	3.06	V
Dropout Voltage (Note 4,5)	$V_D$	$I_L=500\text{mA}$			1.5	V
Line Regulation	$\Delta V_{OUT}$	$I_L=2\text{mA}$ , $V_{IN}-V_{OUT}=2\text{V} \sim V_{IN}=9\text{V}$			0.5	% $V_{OUT}$
Load Regulation (Note 2)	$\Delta V_{OUT}$	$I_L=2\text{mA} \sim 500\text{mA}$ , $V_{IN}-V_{OUT}=2\text{V}$		10	50	mV
Current Limit (Note 3)	$I_{LIMIT}$	$V_{IN}-V_{OUT}=2\text{V}$ , $V_{OUT}=0\text{V}$		550		mA
Standby Current	$I_{ST-BY}$	$I_L=0$ , $V_{IN}=9\text{V}$			5.0	mA

#### For LD3117-ADJ 3.3V, 3.5V, 3.6V, 3.7V, 4.7V, 5.0V

PARAMETER	SYMBOL	TEST CONDITIONS	MIN	TYP	MAX	UNIT	
<b>ADJUSTABLE (<math>R_1=120\Omega</math>, <math>R_2=200\Omega</math>, <math>V_{OUT}=3.3\text{V}</math>)</b>							
Reference Voltage	$V_{REF}$	$V_{IN}-V_{OUT}=2\text{V}$ , $I_L=2\text{mA}$	1.238	1.250	1.262	V	
Output Voltage-LD3117	$V_{OUT}$	$I_L=2\text{mA}$ , $V_{IN}-V_{OUT}=1.4\text{V}$	3.23	3.30	3.37	V	
			3.43	3.50	3.57	V	
			3.53	3.60	3.67	V	
			3.63	3.70	3.77	V	
			4.61	4.70	4.79	V	
			4.90	5.00	5.10	V	
Dropout Voltage (Notes 4, 5)	LD3117	$V_D$	$I_L=500\text{mA}$			1.3	V
	LD3117-ADJ	$V_D$	$I_L=500\text{mA}$			1.5	V
Line Regulation	$\Delta V_{OUT}$	$I_L=2\text{mA}$ , $V_{IN}-V_{OUT}=2\text{V} \sim V_{IN}=12\text{V}$			0.5	% $V_{OUT}$	
Load Regulation (Note 2)	$\Delta V_{OUT}$	$I_L=2\text{mA} \sim 500\text{mA}$ , $V_{IN}-V_{OUT}=2\text{V}$		10	50	mV	
Current Limit (Note 3)	$I_{LIMIT}$	$V_{IN}-V_{OUT}=2\text{V}$ , $V_{OUT}=0\text{V}$		550		mA	
Standby current	$I_{ST-BY}$	$I_L=0$ , $V_{IN}=12\text{V}$			5.0	mA	
Adjust Pin Current	$I_{ADJ}$	$V_{IN}=12\text{V}$			200	$\mu\text{A}$	
Adjust Pin Current Change	$\Delta I_{ADJ}$	$V_{IN}=2.75\text{V} \sim 12\text{V}$ , $I_L=1\text{mA} \sim 500\text{mA}$			5	$\mu\text{A}$	

Notes: 1. Guaranteed by design.

2. Regulation is measured at constant junction temperature, using pulsed ON time.

3. Current Limit is measured at constant junction temperature, using pulsed ON time.

4. Dropout is measured at constant junction temperature, using pulsed ON time, and the criterion is  $V_{OUT}$  inside target value  $\pm 2\%$ .

5: Dropout test is skipped at the condition of  $V_{IN} < 3\text{V}$ .

### ■ TYPICAL APPLICATION CIRCUIT

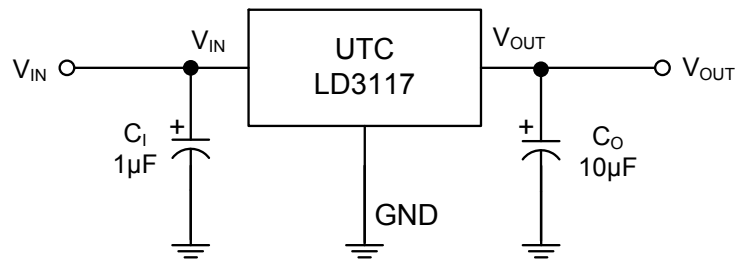

### ■ APPLICATION INFORMATION

A 10µF (or larger) capacitor is recommended between  $V_{OUT}$  and GND for stability. The part may oscillate without the capacitor. Any type of capacitor can be used, but not Aluminum electrolytics when operating below  $-25^{\circ}\text{C}$ . The capacitance may be increased without limit.

A 1µF capacitor (or larger) should be placed between  $V_{IN}$  to GND.

### LD3117 ADJUSTABLE

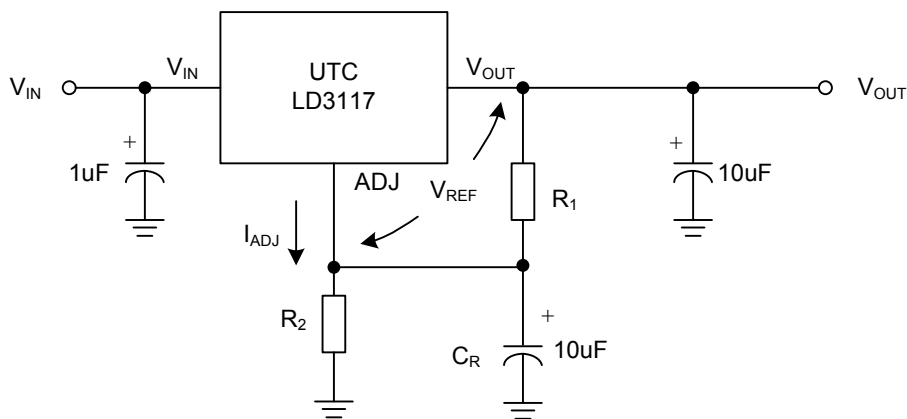

$C_R$ : 10µF to improve ripple rejection

$$V_{OUT} = V_{REF}(1 + R_2/R_1) + I_{ADJ} * R_2$$

UTC assumes no responsibility for equipment failures that result from using products at values that exceed, even momentarily, rated values (such as maximum ratings, operating condition ranges, or other parameters) listed in products specifications of any and all UTC products described or contained herein. UTC products are not designed for use in life support appliances, devices or systems where malfunction of these products can be reasonably expected to result in personal injury. Reproduction in whole or in part is prohibited without the prior written consent of the copyright owner. UTC reserves the right to make changes to information published in this document, including without limitation specifications and product descriptions, at any time and without notice. This document supersedes and replaces all information supplied prior to the publication hereof.