



LCDP1521

Dual line programmable transient voltage suppressor for SLIC protection

Features

- Dual line programmable transient voltage suppressor
- Wide negative firing voltage range:
- $V_{MGL} = -150\text{ V max.}$
- Low dynamic switching voltages: V_{FP} and V_{DGL}
- Low gate triggering current: $I_{GT} = 5\text{ mA max}$
- Peak pulse current: $I_{PP} = 20\text{ A (10/1000 }\mu\text{s)}$
- Holding current: $I_H = 150\text{ mA min}$

Description

This device has been especially designed to protect 2 new high voltage, as well as classical SLICs, against transient overvoltages.

Positive overvoltages are clamped by 2 diodes. Negative surges are suppressed by 2 thyristors, their breakdown voltage being referenced to $-V_{BAT}$ through the gate.

This component presents a very low gate triggering current (I_{GT}) in order to reduce the current consumption on printed circuit board during the firing phase.

Benefits

Trisils are not subject to ageing and provide a fail safe mode in short circuit for a better protection. Trisils are used to help equipment to meet various standards such as UL1950, IEC950 / CSA C22.2, UL1459 and FCC part68. Trisils have UL94 V0 resin approved (Trisils are UL497B approved (file: E136224)).

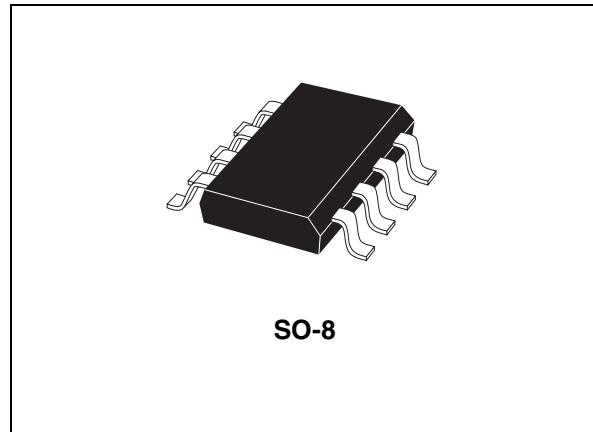

Functional diagram

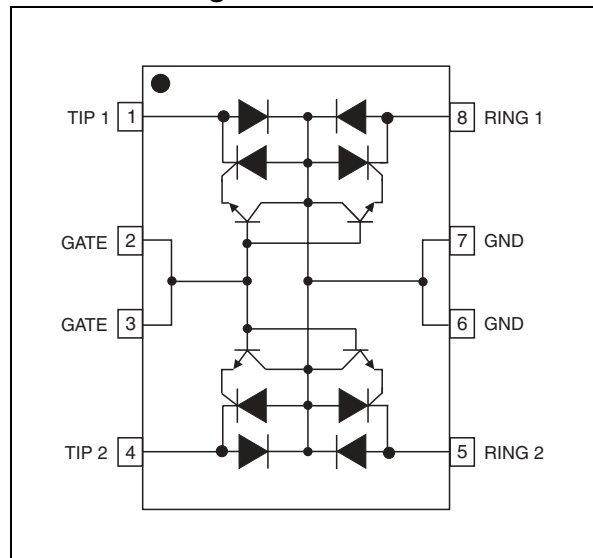

1 Compliant with the following standards

STANDARD	Peak Surge Voltage (V)	Voltage Waveform	Required peak current (A)	Current Waveform	Minimum serial resistor to meet standard (Ω)
GR-1089 Core First level	2500	2/10 μ s	500	2/10 μ s	31
	1000	10/1000 μ s	100	10/1000 μ s	40
GR-1089 Core Second level	5000	2/10 μ s	500	2/10 μ s	62
GR-1089 Core Intra-building	1500	2/10 μ s	100	2/10 μ s	7
ITU-T-K20/K21	6000	10/700 μ s	150	5/310 μ s	200
	1500		37.5		20
ITU-T-K20 (IEC61000-4-2)	8000	1/60 ns	ESD contact discharge		0
	15000		ESD air discharge		0
VDE0433	4000	10/700 μ s	100	5/310 μ s	120
	2000		50		40
VDE0878	4000	1.2/50 μ s	100	1/20 μ s	27
	2000		50		0
IEC61000-4-5	4000	10/700 μ s	100	5/310 μ s	120
	4000	1.2/50 μ s	100	8/20 μ s	27
FCC Part 68, lightning surge type A	1500	10/160 μ s	200	10/160 μ s	43
	800	10/560 μ s	100	10/560 μ s	32
FCC Part 68, lightning surge type B	1000	9/720 μ s	25	5/320 μ s	0

2 Characteristics

2.1 Thermal resistance

Symbol	Parameter	Value	Unit
Rth (j-a)	Junction to ambient	170	$^{\circ}$ C/W

2.2 Electrical characteristics (T_{AMB} = 25°C)

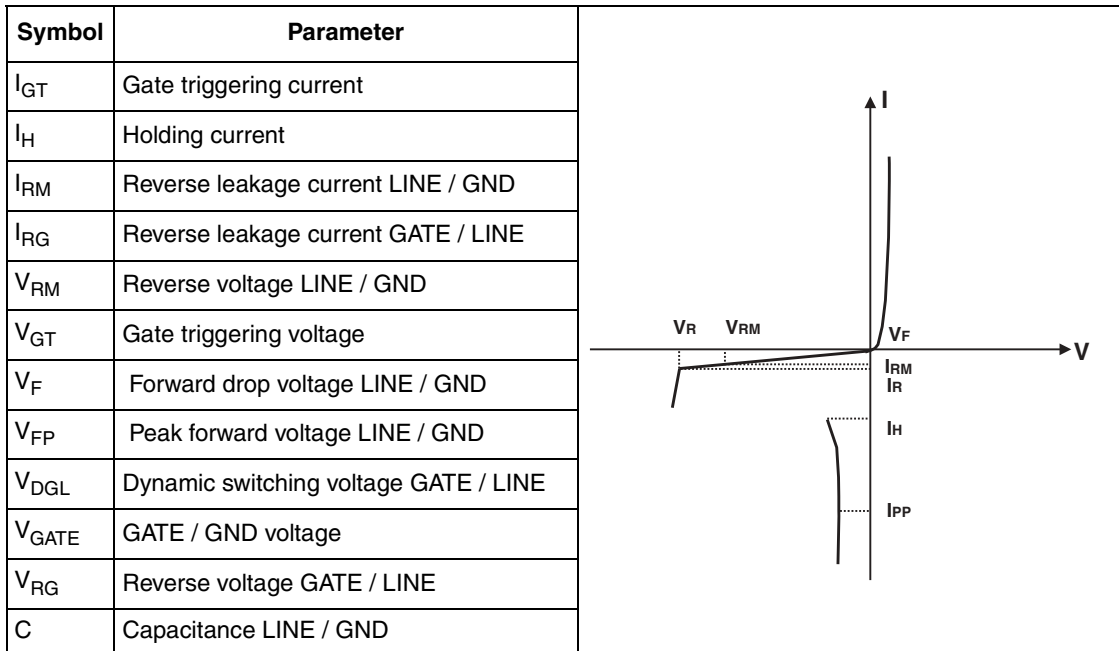

2.3 Absolute ratings (T_{amb} = 25° C, unless otherwise specified).

Symbol	Parameter	Value	Unit	
I _{PP}	Peak pulse current (see note1)	10/1000 μs	20	
		8/20 μs	60	
		10/560 μs	20	
		5/310 μs	25	
		10/160 μs	30	
		1/20 μs	60	
		2/10 μs	70	
I _{TSM}	Non repetitive surge peak on-state current (50 Hz sinusoidal)	t = 10ms	5	
		t = 1s	3.5	
I ² t	I ² t value for fusing (50 Hz sinusoidal)	t = 10 ms	0.125	A ² s
I _{GSM}	Maximum gate current (50 Hz sinusoidal)	t = 10 ms	2	A
V _{MLG}	Maximum voltage LINE/GND	-40° C < T _{amb} < +85° C	-150	V
V _{MGL}	Maximum voltage GATE/LINE	-40° C < T _{amb} < +85° C	-150	
T _{stg}	Storage temperature range	- 55 to + 150	150	°C
T _j	Maximum junction temperature			
T _L	Maximum lead temperature for soldering during 10 s	260	°C	

Figure 1. Repetitive peak pulse current

tr: rise time (μs)
 tp: pulse duration (μs)
 ex: Pulse waveform 10/1000 μs
 tr = 10 μs tp = 1000 μs

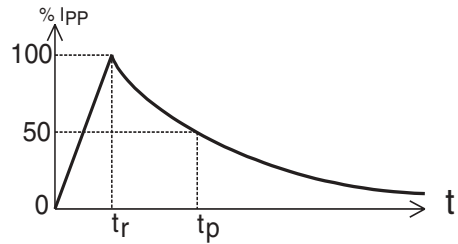

2.4 Parameters related to the diode line / GND ($T_{\text{amb}} = 25^\circ\text{C}$)

Symbol	Test conditions				Max	Unit
V_F	$I_F = 1 \text{ A}$		$t = 500 \mu\text{s}$		2	V
V_{FP} <i>(Note 1)</i>	10/700 μs	1.5 kV	$R_S = 110 \Omega$	$I_{PP} = 10 \text{ A}$	5	V
	1.2/50 μs	1.5 kV	$R_S = 60 \Omega$	$I_{PP} = 15 \text{ A}$	10	
	2/10 μs	2.5 kV	$R_S = 245 \Omega$	$I_{PP} = 10 \text{ A}$	20	

Note: 1 See test circuit for VFP; RS is the protection resistor located on the line card.

2.5 Parameters related to the protection thyristor ($T_{\text{amb}} = 25^\circ\text{C}$ unless otherwise specified)

Symbol	Test conditions				Min	Max	Unit
I_{GT}	$V_{\text{GND}} / \text{LINE} = -48 \text{ V}$				0.1	5	mA
I_H	$V_{\text{GATE}} = -48 \text{ V}$ <i>(Note 2)</i>				150		mA
V_{GT}	at I_{GT}					2.5	V
I_{RG}	$V_{RG} = -150 \text{ V}$		$T_c = 25^\circ\text{C}$			5	μA
	$V_{RG} = -150 \text{ V}$		$T_c = 85^\circ\text{C}$			50	
V_{DGL}	$V_{\text{GATE}} = -48 \text{ V}$ <i>(Note 3)</i>						
	10/700 μs	1.5 kV	$R_S = 110 \Omega$	$I_{PP} = 10 \text{ A}$		5	V
	1.2/50 μs	1.5 kV	$R_S = 60 \Omega$	$I_{PP} = 15 \text{ A}$		10	
2/10 μs	2.5 kV	$R_S = 245 \Omega$	$I_{PP} = 10 \text{ A}$		20		

2 See functional holding current (IH) test circuit

3 See test circuit for VDGL. The oscillations with a time duration lower than 50ns are not taken into account

2.6 Parameters related to diode and protection thyristor
($T_{amb} = 25^\circ C$, unless otherwise specified)

Symbol	Test conditions		Typ.	Max.	Unit
I_{RM}	$V_{GATE / LINE} = -1V$ $V_{RM} = -150 V$ $V_{GATE / LINE} = -1V$ $V_{RM} = -150 V$	$T_c=25^\circ C$ $T_c=85^\circ C$		5 50	μA
C	$V_R = 50 V$ bias, $V_{RMS} = 1 V$, $F = 1 MHz$ $V_R = 2 V$ bias, $V_{RMS} = 1 V$, $F = 1 MHz$		20 48		pF

3 Functional holding current (I_H) test circuit: go no-go test

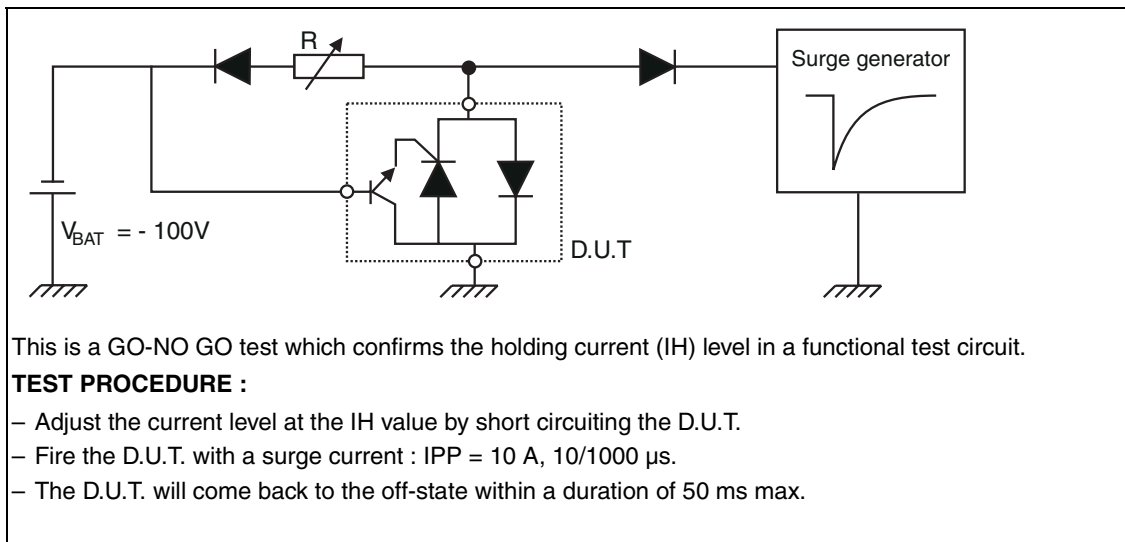

4 Test circuit for v_{fp} and v_{dgl} parameters

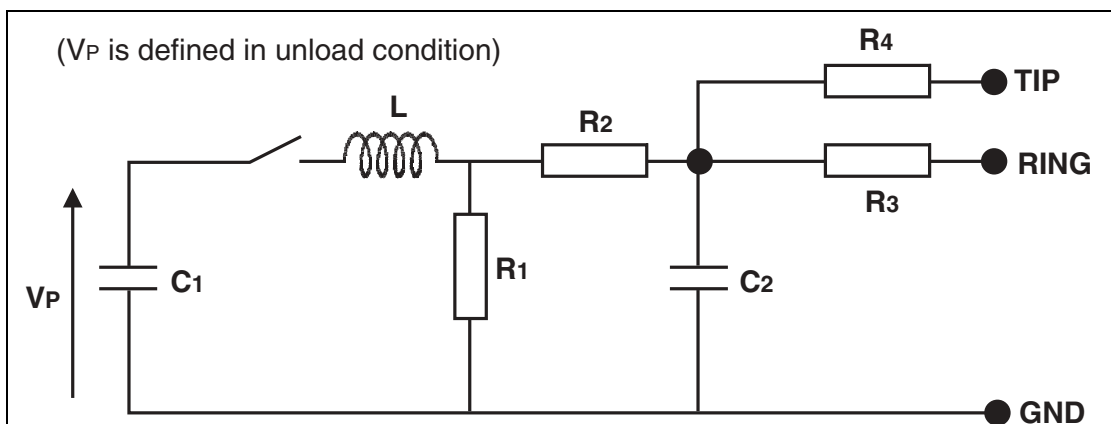

Table 1. Test circuit component values

Pulse (μs)		V_p (V)	C_1 (μF)	C_2 (nF)	L (μH)	R_1 (Ω)	R_2 (Ω)	R_3 (Ω)	R_4 (Ω)	I_{pp} (A)	R_s (Ω)
tr	tp										
10	700	1500	20	200	0	50	15	25	25	10	110
1.2	50	1500	1	33	0	76	13	25	25	15	60
2	10	2500	10	0	1.1	1.3	0	3	3	10	245

5 Technical information

Figure 2. LCDP1521 concept behavior.

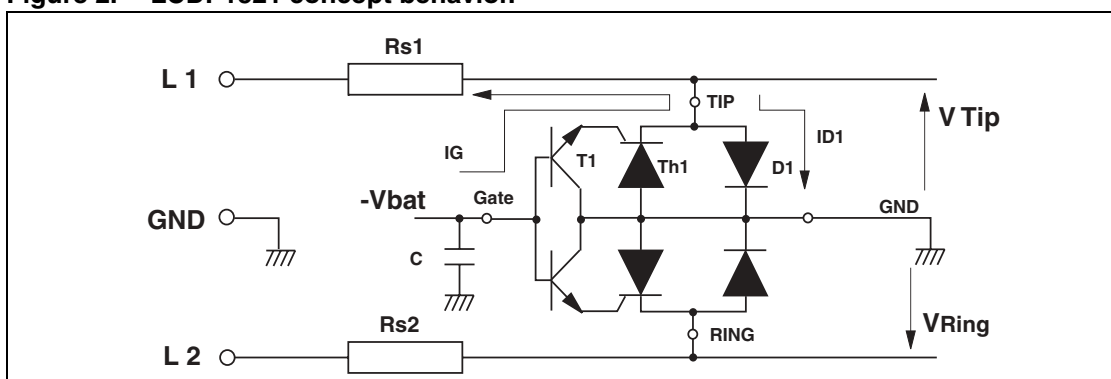

Figure 2 shows the classical protection circuit using the LCDP1521 crowbar concept. This topology has been developed to protect the new high voltage SLICs. This supports the programming of the negative firing threshold while the positive clamping value is fixed at GND.

When a negative surge occurs on one wire (L1 for example), a current I_G flows through the base of the transistor T1 and then injects a current in the gate of the thyristor Th1. Th1 fires and all the surge current flows through the ground. After the surge when the current flowing through Th1 becomes less negative than the holding current I_H , then Th1 switches off.

When a positive surge occurs on one wire (L1 for example), the diode D1 conducts and the surge current flows through the ground.

The capacitor C is used to speed up the crowbar structure firing during the fast surge edges.

This minimizes the dynamic breakover voltage at the SLIC Tip and Ring inputs during fast strikes. Note that this capacitor is generally present around the SLIC - V_{BAT} pin.

So, to be efficient, it has to be as close as possible to the LCDP1521 Gate pin and to the reference ground track (or plan). The optimized value for C is 220 nF.

The series resistors R_{s1} and R_{s2} in *Figure 2* represent the fuse resistors or the PTC which are mandatory to withstand the power contact or the power induction tests imposed by the various country standards. Taking into account this fact, the actual lightning surge current flowing through the LCDP is equal to:

$$I_{\text{surge}} = V_{\text{surge}} / (R_g + R_s)$$

With V_{surge} = peak surge voltage imposed by the standard.

R_g = series resistor of the surge generator

R_s = series resistor of the line card (equivalent to PTC + R on *Figure 3*.)

Example: For a line card with 60 Ω of series resistors which has to be qualified under GR1089 Core 1000V 10/1000 μ s surge, the actual current through the LCDP1521 is equal to:

$$I_{\text{surge}} = 1000 / (10 + 60) = 14A$$

The LCDP1521 is particularly optimized for the new telecom applications such as the fiber in the loop, the WLL, the remote central office. In this case, the operating voltages are smaller than in the classical system. This makes the high voltage SLICs particularly suitable. The schematics of *Figure 3* shows the topologies most frequently used for these applications.

Figure 3. Protection of high voltage SLICs

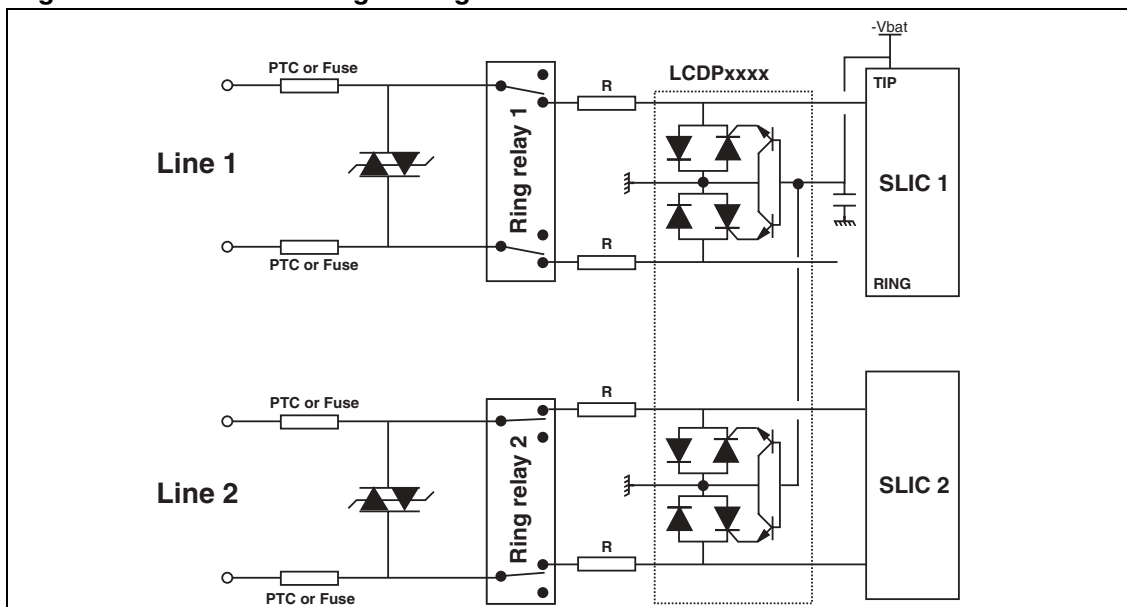

Figure 4. Surge peak current versus overload duration.

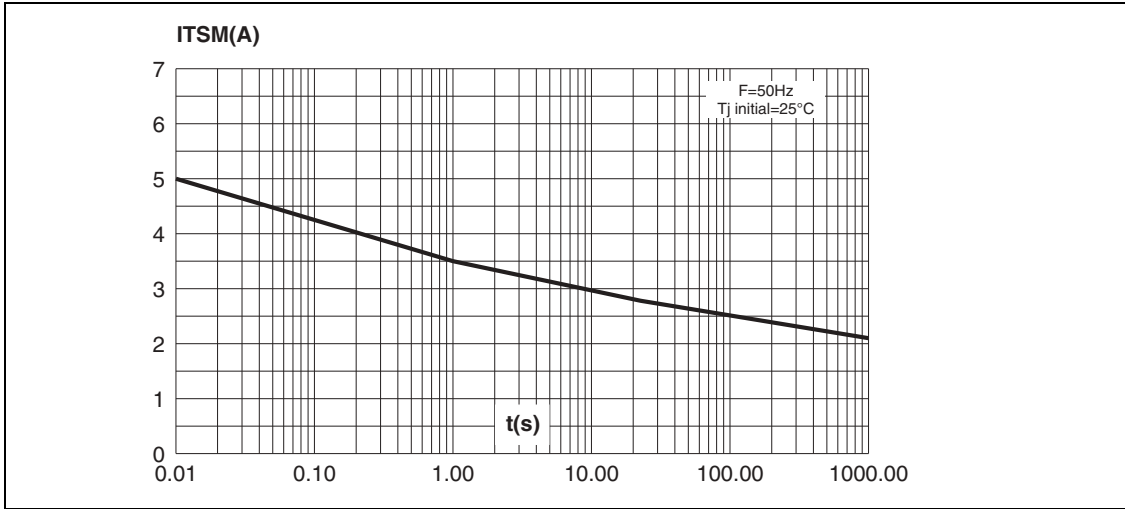
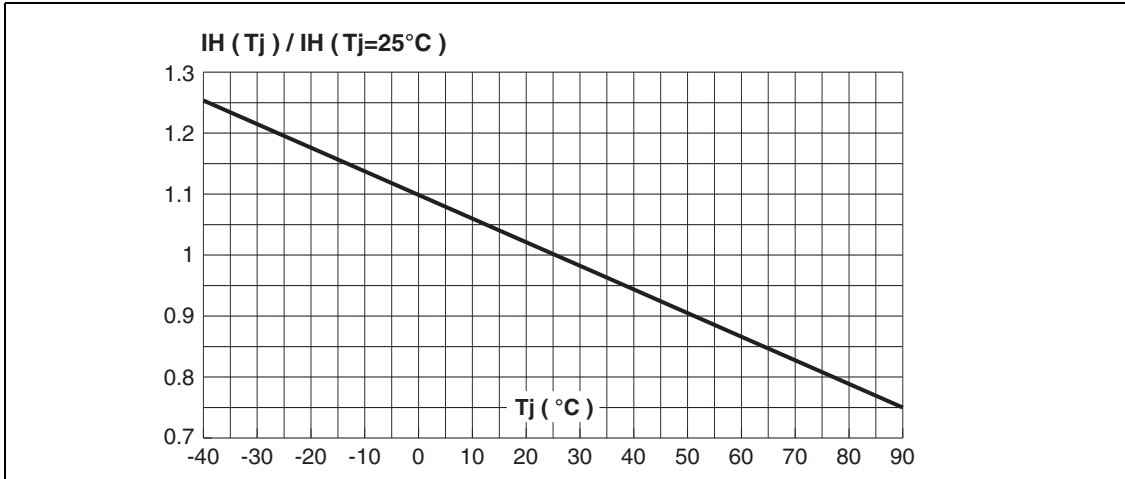
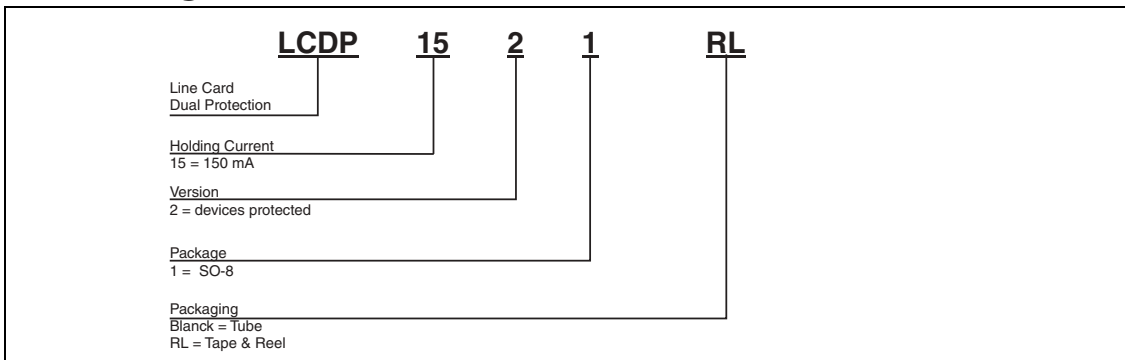

Figure 5. Relative variation of holding current versus junction temperature



6 Ordering information scheme



7 Package mechanical data SO-8 (Plastic)

REF.	DIMENSIONS					
	Millimetres			Inches		
	Min.	Typ.	Max.	Min.	Typ.	Max.
A			1.75			0.069
a1	0.1		0.25	0.004		0.010
a2			1.65			0.065
a3	0.65		0.85	0.025		0.033
b	0.35		0.48	0.014		0.019
b1	0.19		0.25	0.007		0.010
C	0.25	0.50	0.50	0.010		0.020
c1	45° (typ)					
D	4.8		5.0	0.189		0.197
E	5.8		6.2	0.228		0.244
e		1.27			0.050	
e3		3.81			0.150	
F	3.8		4.0	0.15		0.157
L	0.4		1.27	0.016		0.050
M			0.6			0.024
S	8° (max)					

8 Ordering Information

Order code	Marking	Package	Weight	Base qty	Delivery mode
LCDP1521	CDP152	SO-8	0.08 g	100	Tube
LCDP1521RL ⁽¹⁾	CDP152	SO-8	0.08 g	2500	Tape and Reel

1. Preferred device

9 Revision history

Date	Revision	Changes
March 2002	1	Initial release.
24-Jun-2005	2	Peak Pulse Current changed from 15 to 20 A (10/1000 μ s)
07-Feb-2006	3	Added footnote to ordering information table

Information furnished is believed to be accurate and reliable. However, STMicroelectronics assumes no responsibility for the consequences of use of such information nor for any infringement of patents or other rights of third parties which may result from its use. No license is granted by implication or otherwise under any patent or patent rights of STMicroelectronics. Specifications mentioned in this publication are subject to change without notice. This publication supersedes and replaces all information previously supplied. STMicroelectronics products are not authorized for use as critical components in life support devices or systems without express written approval of STMicroelectronics.

The ST logo is a registered trademark of STMicroelectronics.
All other names are the property of their respective owners

© 2006 STMicroelectronics - All rights reserved

STMicroelectronics group of companies

Australia - Belgium - Brazil - Canada - China - Czech Republic - Finland - France - Germany - Hong Kong - India - Israel - Italy - Japan -
Malaysia - Malta - Morocco - Singapore - Spain - Sweden - Switzerland - United Kingdom - United States of America

www.st.com

