



## LC865032A, 865028A, 865024A

### 8-Bit Single-Chip Microcontroller

## Overview

The LC865032A/28A/24A microcontrollers are 8-bit single-chip microcontrollers with the following on-chip functional blocks :

- CPU : Operable at a minimum bus cycle time of 0.5  $\mu$ s (microsecond)
- On-chip ROM capacity : Up to 32K bytes
- On-chip RAM capacity : 512 bytes (LC865032A/28A/24A)
- 16-bit timer/counter (or two 8-bit timers)
- 16-bit timer/PWM (or two 8-bit timers)
- 8-channel  $\times$  8-bit A/D converter
- Two 8-bit synchronous serial-interface circuits
- 13-source 10-vectored interrupt system

All of the functions above are fabricated on a single chip.

## Package Dimensions

unit : mm

### 3071-DIP64S

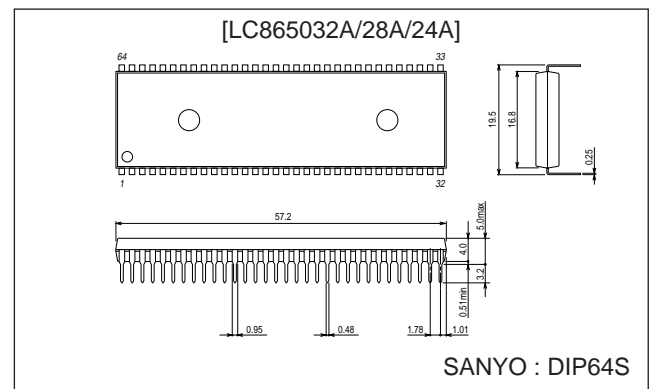

unit : mm

### 3159-QFP64E

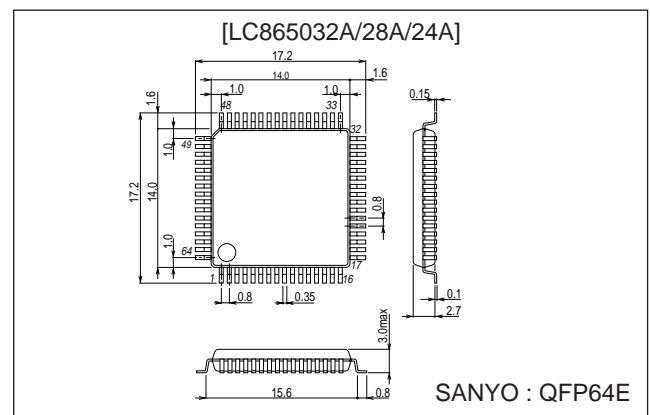

## Features

- (1) Read-Only Memory (ROM) :
 

LC865032A	32512 $\times$ 8 bits
LC865028A	28672 $\times$ 8 bits
LC865024A	24576 $\times$ 8 bits
- (2) Random Access Memory (RAM) :
 

LC865032A/28A/24A	512 $\times$ 8 bits
-------------------	---------------------

## LC865032A, 865028A, 865024A

---

(3) Bus cycle time / Instruction cycle time

The LC865032A/28A/24A microcontrollers are constructed to read ROM twice within one instruction cycle. This results in 1.7 times better performance within the same instruction cycle compared to our 4-bit microcontrollers (the LC66000 series). Bus cycle time indicates the speed to read ROM.

Bus cycle time	Cycle time	System clock oscillation	Oscillation frequency	Supply voltage
0.5 $\mu$ s	1 $\mu$ s	Ceramic resonator	12 MHz	4.5 to 6.0V
2 $\mu$ s	4 $\mu$ s	Ceramic resonator	3 MHz	2.7 to 6.0V
7.5 $\mu$ s	15 $\mu$ s	RC oscillator	800 kHz	2.7 to 6.0V
183 $\mu$ s	366 $\mu$ s	Crystal oscillator	32.768 kHz	2.7 to 6.0V

(4) Ports

- Input/output ports : 6 ports (42 pins)  
Input/output port programmable in nibble units : 1 port (8 pins)  
(However, when N-channel open-drain output is selected, bit-unit input is possible.)  
Input/output port each bit programmable : 5 ports (34 pins)  
Include 15 V withstand N-channel open drain output port : 3 ports (18 pins)
- Input ports : 2 ports (13 pins)

(5) A/D converter

- 8-channel  $\times$  8-bit A/D converter

(6) Serial-interface

- Two 8-bit serial-interface circuits  
LSB first / MSB first functions switchable
- Internal 8-bit band-rate generator in common with two serial-interface circuits

(7) Timer

- Timer 0  
16-bit timer/counter  
2-bit prescaler + 8-bit programmable prescaler  
Mode 0 : Two 8-bit timers with programmable prescaler  
Mode 1 : 8-bit timer with programmable prescaler + 8-bit counter  
Mode 2 : 16-bit timer with programmable prescaler  
Mode 3 : 16-bit counter  
The resolution of Timer is fixed to tCYC. (tCYC : cycle time)
- Timer 1  
16-bit timer/PWM  
Mode 0 : Two 8-bit timers  
Mode 1 : 8-bit timer + 8-bit PWM  
Mode 2 : 16-bit timer  
Mode 3 : Variable-bit PWM (9 to 16 bits)  
In Mode 0 and Mode1, the resolution of Timer and PWM is fixed to tCYC.  
In Mode 2 and Mode 3, the resolution of Timer and PWM can be programmed to be tCYC or 1/2 tCYC
- Base timer  
Every 500 ms overflow system for clock applications (using 32.768 kHz crystal oscillator for Base timer clock)  
Every 976  $\mu$ s, 3.9 ms, 15.6 ms, 62.5 ms overflow system (using 32.768 kHz crystal oscillator for Base timer clock)
- Base timer clock selectable  
32.768 kHz crystal oscillator, system clock, and programmable prescaler output of Timer 0

- (8) Buzzer output
- The buzzer sound frequency is selectable ; 4 kHz, 2 kHz (using 32.768 kHz crystal oscillator for base timer clock)
- (9) Remote-controlled receiver circuit (shares P73/INT3/T0IN pin)
- Noise rejection function
  - Polarity switching
- (10) Watchdog timer
- RC external watchdog timer
  - Watchdog timer operation can be selected : Interrupt/reset
- (11) Interrupt system
- 13-source 10-vectored interrupts :
    1. External interrupt INT0 (including watchdog timer)
    2. External interrupt INT1
    3. External interrupt INT2, Timer/counter T0L (lower 8 bits)
    4. External interrupt INT3, base timer
    5. Timer/counter T0H (upper 8-bits)
    6. Timer T1L, timer T1H
    7. Serial-interface SIO0
    8. Serial-interface SIO1
    9. A/D converter
    10. Port 0
  - Built-in interrupt priority control register  
Microcontroller supports 3 levels of multiple interrupt; low level, high level, and highest level. For the 11 interrupt requests from INT2 through Port 0, high/low level interrupt priority can be specified using the priority control register. Also, for INT0 and INT1, highest/low level interrupt priority can be specified.
- (12) Real-time service operation
- Synchronizing with the interrupt request signals, the real-time service starts a 4-byte data transfer between which special function registers within 1-instruction cycle after the request signal occurs, and then completes its operation within 5-instruction cycles. This operation is performed in parallel with CPU operation.
- (13) Subroutine stack
- 128 levels (Max.) : The stack is located in RAM.
- (14) Multiplication and division
- 16 bits × 8 bits (7-instruction cycles)
  - 16 bits / 8 bits (7-instruction cycles)
- (15) 3 oscillation circuits
- On-chip RC oscillator circuit for the system clock
  - On-chip CF oscillator circuit for the system clock
  - On-chip crystal oscillator circuit for the system clock and the time-base clock  
XT1 pin can be used as P74.

## LC865032A, 865028A, 865024A

---

### (16) Standby function

#### - HALT mode

HALT mode is used to reduce power dissipation. In this mode, program execution is stopped. This mode can be released by an interrupt request signal or initial system reset request signal.

#### - HOLD mode

The HOLD mode is used to stop all oscillators RC (internal), CR and Crystal. This mode can be released by the following operations

- Set Low level to Reset pin ( $\overline{\text{RES}}$ ).
- Set predefined level to P70/INT0, P71/INT1 pins (programmable).
- Set Low level to Port 0 pin/pins (programmable).

### (17) Factory shipment

- DIP64S, QFP64E delivery form

### (18) Development support tools

Evaluation (EVA) chip	:	LC866098	
EPROM version	:	LC86E5032	
One time ROM version	:	LC86P5032	
Emulator	:	EVA-86000 + ECB866600 (Evaluation chip board)	
			{ + POD865000 (POD for DIP64S)
			{ + POD865010 (POD for QFP64E)

# LC865032A, 865028A, 865024A

## Pin Assignments

### DIP64S

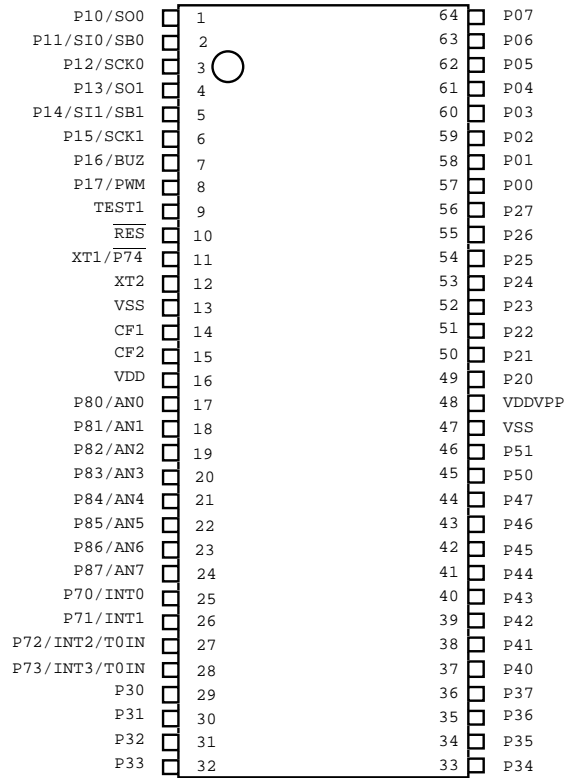

Top view

### QFP64E

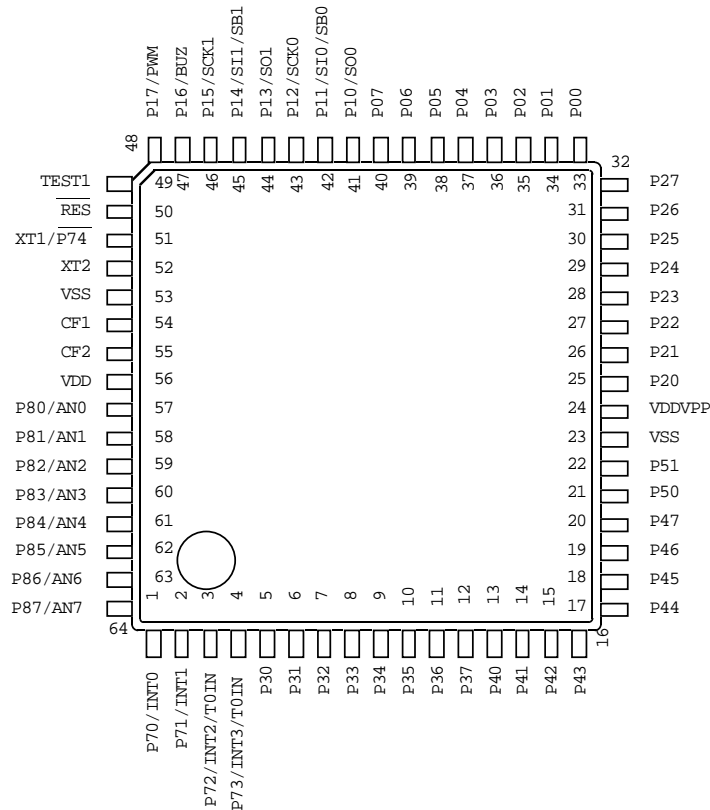

Top view

System Block Diagram

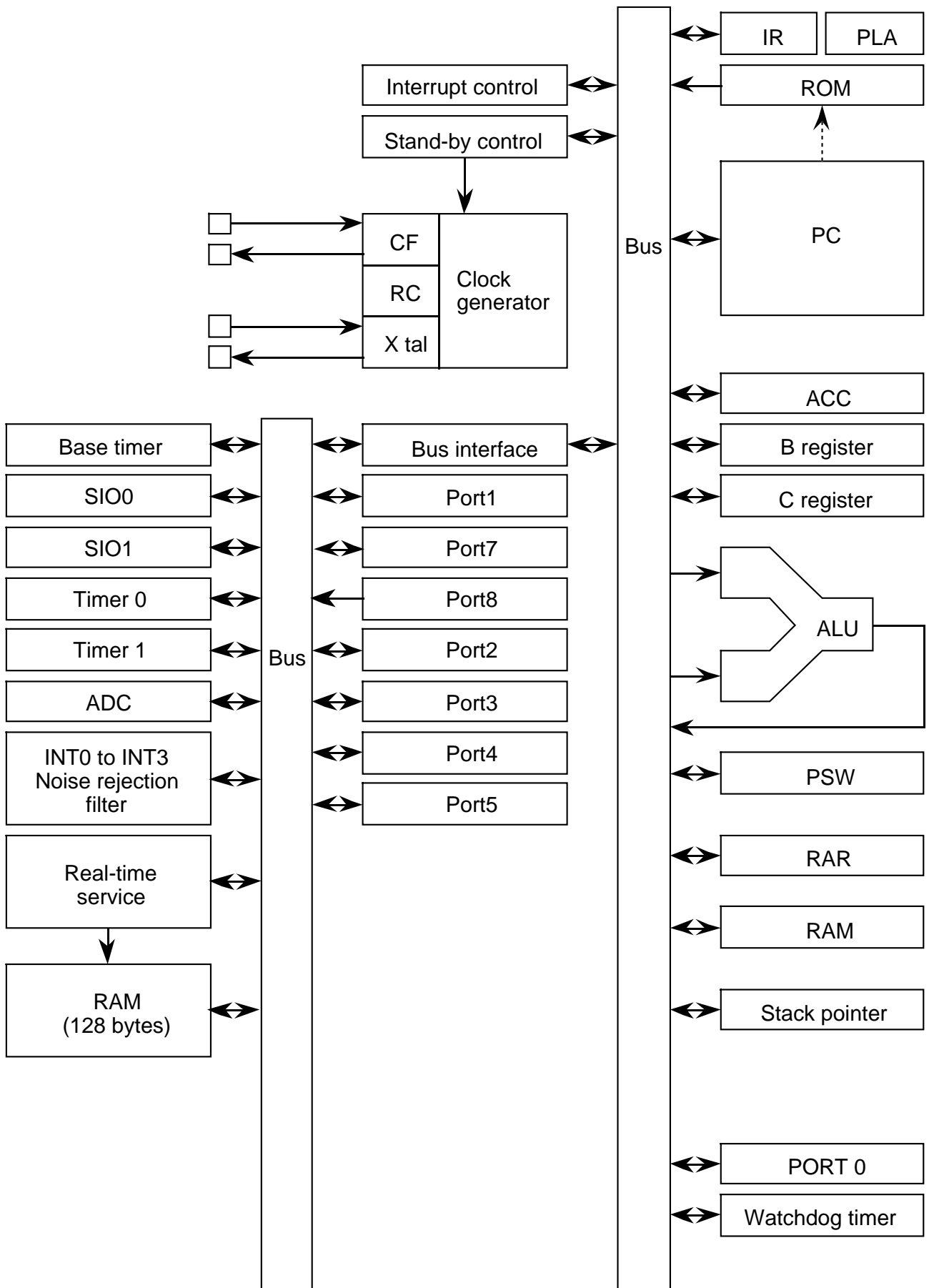

Pin Description

Pin name	I/O	Function description	Option
VSS		Power supply (-)	
VDD		Power supply (+)	
VDDVPP*		Power supply (+)	
PORT0 P00 to P07	I/O	<ul style="list-style-type: none"> <li>8-bit input/output port</li> <li>Input for port 0 interrupt</li> <li>Data direction programmable in nibble units</li> <li>Input for HOLD release</li> </ul>	<ul style="list-style-type: none"> <li>Pull-up resistor : Present / Not present</li> <li>Output form : CMOS/N-channel open-drain</li> </ul>
PORT1 P10 to P17	I/O	<ul style="list-style-type: none"> <li>8-bit input/output port</li> <li>Data direction can be specified for each bit.</li> <li>Other pin functions                             <ul style="list-style-type: none"> <li>P10 SIO0 data output</li> <li>P11 SIO0 data input /bus input/output</li> <li>P12 SIO0 clock input/output</li> <li>P13 SIO1 data output</li> <li>P14 SIO1 data input /bus input/output</li> <li>P15 SIO1 clock input/output</li> <li>P16 Buzzer output</li> <li>P17 Timer1 output (PWM output)</li> </ul> </li> </ul>	<ul style="list-style-type: none"> <li>Output form : CMOS/N-channel open-drain</li> </ul>
PORT2 P20 to P27	I/O	<ul style="list-style-type: none"> <li>8-bit input/output port</li> <li>Input/output in bit units</li> </ul>	<ul style="list-style-type: none"> <li>Output form : CMOS/N-channel open-drain</li> </ul>
PORT3 P30 to P37	I/O	<ul style="list-style-type: none"> <li>8-bit input/output port</li> <li>Input/output in bit units</li> <li>15 V withstand at N-channel open-drain output</li> </ul>	<ul style="list-style-type: none"> <li>Pull-up resistor : Present / Not present</li> <li>Output form : CMOS/N-channel open-drain</li> </ul>
PORT4 P40 to P47	I/O	<ul style="list-style-type: none"> <li>8-bit input/output port</li> <li>Input/output in bit units</li> <li>15 V withstand at N-channel open-drain output</li> </ul>	<ul style="list-style-type: none"> <li>Pull-up resistor : Present / Not present</li> <li>Output form : CMOS/N-channel open-drain</li> </ul>
PORT5 P50 , P51	I/O	<ul style="list-style-type: none"> <li>2-bit input/output port</li> <li>Input/output in bit units</li> <li>15 V withstand at N-channel open-drain output</li> </ul>	<ul style="list-style-type: none"> <li>Pull-up resistor : Present / Not present</li> <li>Output form : CMOS/N-channel open-drain</li> </ul>

\* Connect as in the following figure to reduce noise into VDD.  
 Short-circuit the V<sub>DD</sub> terminal to the VDDVPP pin.  
 Short-circuit the two VSS pins.

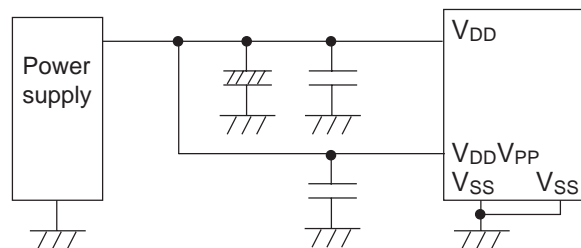

## LC865032A, 865028A, 865024A

Pin name	I/O	Function description	Option																																			
PORT7 P70 P71 to $\overline{P74}$	I/O  I	<ul style="list-style-type: none"> <li>• 5-bit input port</li> <li>• Other pin functions</li> </ul> P70: INT0 input / HOLD release / N-channel Tr. output for watchdog timer P71: INT1 input / HOLD release input P72: INT2 input / timer 0 event input P73: INT3 input with noise filter/timer 0 event input $\overline{P74}$ : XT1 input pin for 32.768 kHz crystal oscillator <ul style="list-style-type: none"> <li>• Interrupt received form, vector address</li> </ul> <table border="1" style="margin-left: 20px;"> <thead> <tr> <th></th> <th>Rising</th> <th>Falling</th> <th>Rising &amp; falling</th> <th>High level</th> <th>Low level</th> <th>Vector</th> </tr> </thead> <tbody> <tr> <td>INT0</td> <td>Enable</td> <td>Enable</td> <td>Disable</td> <td>Enable</td> <td>Enable</td> <td>03H</td> </tr> <tr> <td>INT1</td> <td>Enable</td> <td>Enable</td> <td>Disable</td> <td>Enable</td> <td>Enable</td> <td>0BH</td> </tr> <tr> <td>INT2</td> <td>Enable</td> <td>Enable</td> <td>Enable</td> <td>Disable</td> <td>Disable</td> <td>13H</td> </tr> <tr> <td>INT3</td> <td>Enable</td> <td>Enable</td> <td>Enable</td> <td>Disable</td> <td>Disable</td> <td>1BH</td> </tr> </tbody> </table>		Rising	Falling	Rising & falling	High level	Low level	Vector	INT0	Enable	Enable	Disable	Enable	Enable	03H	INT1	Enable	Enable	Disable	Enable	Enable	0BH	INT2	Enable	Enable	Enable	Disable	Disable	13H	INT3	Enable	Enable	Enable	Disable	Disable	1BH	Pull-up resistor : Present / Not present (P70,71,72,73) * $\overline{P74}$ does not have pull-up resistor option.
	Rising	Falling	Rising & falling	High level	Low level	Vector																																
INT0	Enable	Enable	Disable	Enable	Enable	03H																																
INT1	Enable	Enable	Disable	Enable	Enable	0BH																																
INT2	Enable	Enable	Enable	Disable	Disable	13H																																
INT3	Enable	Enable	Enable	Disable	Disable	1BH																																
PORT8 P80 to P87	I	<ul style="list-style-type: none"> <li>• 8-bit input port</li> <li>• Other function</li> </ul> A/D input port (8 port pins)																																				
$\overline{RES}$	I	Reset pin with pull-up resistor																																				
TEST1	O	<ul style="list-style-type: none"> <li>• Test pin</li> <li>Should be left open.</li> <li>• Output fixed HIGH</li> </ul>																																				
$\overline{XT1/P74}$	I	<ul style="list-style-type: none"> <li>• Input pin for 32.768 kHz crystal oscillator</li> <li>• Other function</li> </ul> Input port $\overline{P74}$ When not in use, connect to $V_{DD}$ .																																				
XT2	O	Output pin for 32.768 kHz crystal oscillator When not in use, should be left open.																																				
CF1	I	Input pin for ceramic resonator oscillator																																				
CF2	O	Output pin for ceramic resonator oscillator																																				

• All port options can be specified for each bit.

• State of pins at reset

Pin name	Input/output mode	State of pull-up resistor specified at pull-up option
Port 0 P70, 71, 72, 73	Input	Fixed pull-up resistor exist
Ports 1, 2 Ports 3, 4, 5	Input	Programmable pull-up resistor OFF



## Specifications

### 1. Absolute Maximum Ratings at $T_a = 25^\circ\text{C}$ , $V_{SS} = 0\text{ V}$

Parameter		Symbol	Pins	Conditions	Ratings			Unit		
					$V_{DD}[\text{V}]$	min	typ		max	
Supply voltage		$V_{DD\text{ max}}$	VDD, VDDVPP	$V_{DD} = V_{DDVPP}$		-0.3		+7.0	V	
Input voltage		$V_{I(1)}$	<ul style="list-style-type: none"> <li>• P71, 72, 73, <math>\overline{74}</math></li> <li>• Port 8</li> <li>• RES</li> </ul>			-0.3		$V_{DD}+0.3$		
Input/output voltage		$V_{IO(1)}$	<ul style="list-style-type: none"> <li>• Ports 0, 1, 2</li> <li>• Ports 3, 4, 5 at CMOS output option</li> </ul>			-0.3		$V_{DD}+0.3$		
		$V_{IO(2)}$	P 3, 4, 5 at N-ch open-drain output option			-0.3		+15		
High-level output current	Peak output current	$I_{OPH(1)}$	Ports 0, 1, 2, 3, 4, 5	CMOS output at each pin		-4			mA	
	Total output current	$I_{OAH(1)}$	Ports 0, 1	Total of all pins		-20				
		$I_{OAH(2)}$	Ports 2, 3, 4, 5	Total of all pins			-20			
Low-level output current	Peak output current	$I_{OPL(1)}$	Ports 0, 1, 2, 3, 4, 5	At each pin				20		
		$I_{OPL(2)}$	P70	At each pin				15		
	Total output current	$I_{OAL(1)}$	Port 0 P70	Total of all pins					40	
		$I_{OAL(2)}$	Port 2	Total of all pins					40	
		$I_{OAL(3)}$	Ports 3, 4, 5	Total of all pins					80	
Power dissipation (max.)		$P_d\text{ max (1)}$	DIP64S	$T_a = -30\text{ to }+70^\circ\text{C}$				700	mW	
		$P_d\text{ max (2)}$	QFP64E	$T_a = -30\text{ to }+70^\circ\text{C}$				420		
Operating temperature range		$T_{opr}$				-30		+70	$^\circ\text{C}$	
Storage temperature range		$T_{stg}$				-65		+150		

## LC865032A, 865028A, 865024A

### 2. Recommended Operating Ranges at Ta = -30°C to +70°C, V<sub>SS</sub> = 0 V

Parameter	Symbol	Pins	Conditions	Ratings			Unit	
				V <sub>DD</sub> [V]	min	typ		max
Operating voltage range	V <sub>DD</sub> (1)	VDD	0.98 μs tCYC tCYC 400 μs		4.5		6.0	V
	V <sub>DD</sub> (2)		3.9 μs tCYC tCYC 400 μs		2.7		6.0	
HOLD voltage	V <sub>HD</sub>	VDD	RAM and Registers hold voltage at HOLD mode.		2.0		6.0	
Input high-level voltage	V <sub>IH</sub> (1)	Port 0 (Schmitt)	Output disable	2.7 to 6.0	0.4V <sub>DD</sub> +0.9		V <sub>DD</sub>	
	V <sub>IH</sub> (2)	• Ports 1, 2 • P72, 73 (Schmitt)	Output disable	2.7 to 6.0	0.75V <sub>DD</sub>		V <sub>DD</sub>	
	V <sub>IH</sub> (3)	• P70 Port input/interrupt • P71 • RES (Schmitt)	Output N-channel transistor OFF	2.7 to 6.0	0.75V <sub>DD</sub>		V <sub>DD</sub>	
	V <sub>IH</sub> (4)	P70 Watchdog timer	Output N-channel transistor OFF	2.7 to 6.0	0.9V <sub>DD</sub>		V <sub>DD</sub>	
	V <sub>IH</sub> (5)	• P74 • Port 8	Output N-channel transistor OFF	2.7 to 6.0	0.75V <sub>DD</sub>		V <sub>DD</sub>	
	V <sub>IH</sub> (6)	Ports 3, 4, 5 of CMOS output (Schmitt)	Output disable	4.0 to 6.0 2.7 to 4.0	0.75V <sub>DD</sub> 0.8V <sub>DD</sub>		V <sub>DD</sub> V <sub>DD</sub>	
	V <sub>IH</sub> (7)	Ports 3, 4, 5 of open-drain output (Schmitt)	Output disable	4.0 to 6.0 2.7 to 4.0	0.75V <sub>DD</sub> 0.8V <sub>DD</sub>		13.5 13.5	
Input low-level voltage	V <sub>IL</sub> (1)	Port 0 (Schmitt)	Output disable	2.7 to 6.0	V <sub>SS</sub>		0.2V <sub>DD</sub>	
	V <sub>IL</sub> (2)	• Ports 1, 2, 3, 4, 5 • P72, 73 (Schmitt)	Output disable	2.7 to 6.0	V <sub>SS</sub>		0.25V <sub>DD</sub>	
	V <sub>IL</sub> (3)	• P70 Port input/interrupt • P71 • RES (Schmitt)	N-channel transistor OFF	2.7 to 6.0	V <sub>SS</sub>		0.25V <sub>DD</sub>	
	V <sub>IL</sub> (4)	P70 Watchdog timer	N-channel transistor OFF	2.7 to 6.0	V <sub>SS</sub>		0.8V <sub>DD</sub> -1.0	
	V <sub>IL</sub> (5)	• P74 • Port 8	Output N-channel transistor OFF	2.7 to 6.0	V <sub>SS</sub>		0.25V <sub>DD</sub>	
Operating cycle time	tCYC			4.5 to 6.0	0.98		400	μs
				2.7 to 6.0	3.9		400	

## LC865032A, 865028A, 865024A

Parameter	Symbol	Pins	Conditions	Ratings			Unit	
				V <sub>DD</sub> [V]	min	typ		max
Oscillation frequency range (Note 1)	FmCF(1)	CF1, CF2	<ul style="list-style-type: none"> <li>• 12 MHz (ceramic resonator oscillation).</li> <li>• Refer to Figure 1.</li> </ul>	4.5 to 6.0	11.76	12	12.24	MHz
	FmCF(2)	CF1, CF2	<ul style="list-style-type: none"> <li>• 3 MHz (ceramic resonator oscillation).</li> <li>• Refer to Figure 1.</li> </ul>	2.7 to 6.0	2.94	3	3.06	
	FmRC		RC oscillation	2.7 to 6.0	0.4	0.8	3.0	
	FsXtal	XT1, XT2	<ul style="list-style-type: none"> <li>• 32.768 kHz (crystal oscillation).</li> <li>• Refer to Figure 2.</li> </ul>	2.7 to 6.0		32.768		kHz
Oscillation stable time period (Note 1)	tmsCF(1)	CF1, CF2	<ul style="list-style-type: none"> <li>• 12 MHz (ceramic resonator oscillation).</li> <li>• Refer to Figure 3.</li> </ul>	4.5 to 6.0		0.03	0.5	ms
	tmsCF(2)	CF1, CF2	<ul style="list-style-type: none"> <li>• 3 MHz (ceramic resonator oscillation).</li> <li>• Refer to Figure 3.</li> </ul>	4.5 to 6.0		0.2	2	
				2.7 to 6.0		0.2	6	
	tssXtal	XT1, XT2	<ul style="list-style-type: none"> <li>• 32.768 kHz (crystal oscillation).</li> <li>• Refer to Figure 3.</li> </ul>	4.5 to 6.0		1	1.5	s
				2.7 to 6.0		1	3	

(Note 1) Refer to Table 1 and Table 2 for oscillation constant.

**LC865032A, 865028A, 865024A**

**3. Electrical Characteristics at Ta = -30°C to +70°C, VSS = 0 V**

Parameter	Symbol	Pins	Conditions	Ratings			Unit	
				VDD[V]	min	typ		max
Input high-level current	I <sub>IH</sub> (1)	Ports 3, 4, 5 of open-drain output	<ul style="list-style-type: none"> <li>Output disabled</li> <li>V<sub>IN</sub> = 13.5 V (including off-state leak current of the output transistor)</li> </ul>	2.7 to 6.0			5	μA
	I <sub>IH</sub> (2)	<ul style="list-style-type: none"> <li>Port 0 without pull-up MOS transistor</li> <li>Ports 1, 2, 3, 4, 5</li> </ul>	<ul style="list-style-type: none"> <li>Output disabled</li> <li>Pull-up MOS transistor OFF.</li> <li>V<sub>IN</sub> = V<sub>DD</sub> (including off-state leak current of the output transistor)</li> </ul>	2.7 to 6.0			1	
	I <sub>IH</sub> (3)	<ul style="list-style-type: none"> <li>P70, 71, 72, 73 without pull-up MOS transistor</li> <li>Port 8</li> </ul>	V <sub>IN</sub> = V <sub>DD</sub>	2.7 to 6.0			1	
	I <sub>IH</sub> (4)	$\overline{\text{RES}}$	V <sub>IN</sub> = V <sub>DD</sub>	2.7 to 6.0			1	
Input low-level current	I <sub>IL</sub> (1)	<ul style="list-style-type: none"> <li>Ports 1, 2, 3, 4, 5</li> <li>Port 0 without pull-up MOS transistor</li> </ul>	<ul style="list-style-type: none"> <li>Output disabled</li> <li>Pull-up MOS transistor OFF.</li> <li>V<sub>IN</sub> = V<sub>SS</sub> (including off-state leak current of the output transistor)</li> </ul>	2.7 to 6.0	-1			
	I <sub>IL</sub> (2)	<ul style="list-style-type: none"> <li>P70, 71, 72, 73 without pull-up MOS transistor</li> <li>Port 8</li> </ul>	V <sub>IN</sub> = V <sub>SS</sub>	2.7 to 6.0	-1			
	I <sub>IL</sub> (3)	$\overline{\text{RES}}$	V <sub>IN</sub> = V <sub>SS</sub>	2.7 to 6.0	-1			
Output high-level voltage	V <sub>OH</sub> (1)	Ports 1, 2, 3, 4, 5 of CMOS output	I <sub>OH</sub> = -1 mA	4.5 to 6.0	V <sub>DD</sub> -1			V
	V <sub>OH</sub> (2)		I <sub>OH</sub> = -0.1 mA	2.7 to 6.0	V <sub>DD</sub> -0.5			
Output low-level voltage	V <sub>OL</sub> (1)	Ports 1, 2, 3, 4, 5	I <sub>OL</sub> = 10 mA	4.5 to 6.0			1.5	
	V <sub>OL</sub> (2)		I <sub>OL</sub> = 1.6 mA	4.5 to 6.0			0.4	
	V <sub>OL</sub> (3)		<ul style="list-style-type: none"> <li>I<sub>OL</sub> = 1.0 mA</li> <li>The current of any unmeasured pin is 1 mA or less.</li> </ul>	2.7 to 6.0			0.4	
	V <sub>OL</sub> (4)	P70	I <sub>OL</sub> = 1 mA	4.5 to 6.0			0.4	
	V <sub>OL</sub> (5)		I <sub>OL</sub> = 0.5 mA	2.7 to 6.0			0.4	
Pull-up MOS transistor resistor	R <sub>pu</sub>	<ul style="list-style-type: none"> <li>Ports 1, 2, 3, 4, 5</li> <li>P70, 71, 72, 73</li> </ul>	V <sub>OH</sub> = 0.9 V <sub>DD</sub>	4.5 to 6.0	15	40	70	k
				2.7 to 4.5	25	70	150	
Hysteresis voltage	V <sub>HIS</sub>	<ul style="list-style-type: none"> <li>Ports 1, 2, 3, 4, 5</li> <li>P70, 71, 72, 73</li> <li><math>\overline{\text{RES}}</math></li> </ul>	Output disable	2.7 to 6.0		0.1V <sub>DD</sub>		V
Pin capacitance	CP	All pins	<ul style="list-style-type: none"> <li>f = 1 MHz</li> <li>Unmeasured input pins are set to V<sub>SS</sub> level.</li> <li>Ta = 25°C</li> </ul>	2.7 to 6.0		10		pF

4. Serial Input/Output Characteristics at Ta = -30°C to +70°C, VSS = 0 V

Parameter		Symbol	Pins	Conditions	Ratings			Unit		
					VDD[V]	min	typ		max	
Serial clock	Input clock	Cycle	tCKCY(1)	SCK0, SCK1	Refer to Figure 5.	2.7 to 6.0	2		tCYC	
		Low-level pulse width	tCKL(1)			2.7 to 6.0	1			
		High-level pulse width	tCKH(1)			2.7 to 6.0	1			
	Output clock	Cycle	tCKCY(2)	SCK0, SCK1	<ul style="list-style-type: none"> <li>• Use an external pull-up resistor (1 k ) with open-drain output.</li> <li>• Refer to Figure 5.</li> </ul>	2.7 to 6.0	2			
		Low-level pulse width	tCKL(2)			2.7 to 6.0		1/2tCKCY		
		High-level pulse width	tCKH(2)			2.7 to 6.0		1/2tCKCY		
Serial input	Data setup time	tICK	<ul style="list-style-type: none"> <li>• SI0, SI1</li> <li>• SB0, SB1</li> </ul>	<ul style="list-style-type: none"> <li>• Set to the rise of SCK0, SCK1.</li> <li>• Refer to Figure 5.</li> </ul>	4.5 to 6.0	0.1		μs		
					2.7 to 6.0	0.4				
	Data hold time	tCKI			4.5 to 6.0	0.1				
					2.7 to 6.0	0.4				
Serial output	Output delay time (Serial clock is external clock.)	tCKO(1)	<ul style="list-style-type: none"> <li>• SO0, SO1</li> <li>• SB0, SB1</li> </ul>	<ul style="list-style-type: none"> <li>• Use an external pull-up resistor (1 k ) with open-drain output.</li> <li>• Set to the fall of SCK0, SCK1.</li> <li>• Refer to Figure 5.</li> </ul>	4.5 to 6.0			7/12tCYC +0.2		
					2.7 to 6.0			7/12tCYC +1		
	Output delay time (Serial clock is internal clock.)	tCKO(2)			4.5 to 6.0			1/3tCYC +0.2		
					2.7 to 6.0			1/3tCYC +1		

## LC865032A, 865028A, 865024A

### 5. Pulse Input Conditions at Ta = -30°C to +70°C, VSS = 0 V

Parameter	Symbol	Pins	Conditions	Ratings			Unit	
				VDD[V]	min	typ		max
High/low-level pulse width	tPIH(1) tPIL(1)	• INT0, INT1 • INT2/T0IN • INT3	• Interrupt acceptable • Timer/counter 0 pulse countable	2.7 to 6.0	1			tCYC
	tPIH(2) tPIL(2)	INT3/T0IN (Noise rejection filter time constant is 1/1.)	Interrupt acceptable	2.7 to 6.0	2			
	tPIH(3) tPIL(3)	INT3/T0IN (Noise rejection filter time constant is 1/16.)	Interrupt acceptable	2.7 to 6.0	32			
	tPIL(4)	$\overline{\text{RES}}$	Reset acceptable	2.7 to 6.0	200			μs

### 6. A/D Converter Characteristics at Ta = -30°C to +70°C, VSS = 0 V

Parameter	Symbol	Pins	Conditions	Ratings			Unit		
				VDD[V]	min	typ		max	
Resolution	N			4.5 to 6.0		8		bit	
Absolute precision	ET		(Note 2)	4.5 to 6.0			±1.5	LSB	
Conversion time	tCAD		A/D conversion time = 16 × tCYC (ADCR2 = 0) (Note 3)	4.5 to 6.0			15.68 (tCYC = 0.98 μs)	65.28 (tCYC = 4.08 μs)	μs
			A/D conversion time = 32 × tCYC (ADCR2 = 1) (Note 3)				31.36 (tCYC = 0.98 μs)	130.56 (tCYC = 4.08 μs)	
Analog input voltage range	VAIN	AN0 to AN7		4.5 to 6.0	VSS		VDD	V	
Analog port input current	I <sub>AINH</sub>		VAIN = VDD	4.5 to 6.0			+1	μA	
	I <sub>AINL</sub>		VAIN = VSS	4.5 to 6.0	-1				

(Note 2) Quantizing error (±1/2 LSB) is not included.

(Note 3) Conversion time is the period from execution of instruction starting the conversion to completion of shifting the A/D converted value to the register.

7. Current Drain Characteristics at Ta = -30°C to +70°C, VSS = 0 V

Parameter	Symbol	Pins	Conditions	Ratings			Unit	
				V <sub>DD</sub> [V]	min	typ		max
Current drain during basic operation (Note 4)	I <sub>DDOP</sub> (1)	VDD	<ul style="list-style-type: none"> <li>• FmCF = 12 MHz for ceramic resonator oscillation.</li> <li>• FsXtal = 32.768 kHz for crystal oscillator.</li> <li>• System clock : CF oscillator</li> <li>• Internal RC oscillator stopped.</li> </ul>	4.5 to 6.0		10	20	mA
	I <sub>DDOP</sub> (2)		<ul style="list-style-type: none"> <li>• FmCF = 3 MHz for ceramic resonator oscillation.</li> <li>• FsXtal = 32.768 kHz for crystal oscillator.</li> <li>• System clock : CF oscillator</li> <li>• Internal RC oscillator stopped.</li> </ul>	4.5 to 6.0		3	7	
	I <sub>DDOP</sub> (3)			2.7 to 4.5		1.5	5	
	I <sub>DDOP</sub> (4)		<ul style="list-style-type: none"> <li>• FmCF = 0 Hz (when oscillator stops).</li> <li>• FsXtal = 32.768 kHz for crystal oscillator.</li> <li>• System clock : RC oscillator</li> </ul>	4.5 to 6.0		0.7	3.0	
	I <sub>DDOP</sub> (5)			2.7 to 4.5		0.4	2.5	
	I <sub>DDOP</sub> (6)		<ul style="list-style-type: none"> <li>• FmCF = 0 Hz (when oscillator stops).</li> <li>• FsXtal = 32.768 kHz for crystal oscillator.</li> <li>• System clock : 32.768 kHz</li> <li>• Internal RC oscillator stopped.</li> </ul>	4.5 to 6.0		35	100	
	I <sub>DDOP</sub> (7)			2.7 to 4.5		15	50	

## LC865032A, 865028A, 865024A

Parameter	Symbol	Pins	Conditions	Ratings			Unit		
				V <sub>DD</sub> [V]	min	typ		max	
Current drain at HALT mode (Note 4)	I <sub>DDHALT</sub> (1)	VDD	<ul style="list-style-type: none"> <li>• HALT mode</li> <li>• FmCF = 12 MHz for ceramic resonator oscillation.</li> <li>• FsXtal = 32.768 kHz for crystal oscillator.</li> <li>• System clock : CF oscillator.</li> <li>• Internal RC oscillator stopped.</li> </ul>	4.5 to 6.0		5	10	mA	
	I <sub>DDHALT</sub> (2)		<ul style="list-style-type: none"> <li>• HALT mode</li> <li>• FmCF = 3 MHz for ceramic resonator oscillation.</li> <li>• FsXtal = 32.768 kHz for crystal oscillator.</li> <li>• System clock : CF oscillator.</li> <li>• Internal RC oscillator stopped.</li> </ul>	4.5 to 6.0		2.2	4.6		
	I <sub>DDHALT</sub> (3)		<ul style="list-style-type: none"> <li>• Internal RC oscillator stopped.</li> </ul>	2.7 to 4.5		0.8	2.5		
	I <sub>DDHALT</sub> (4)		VDD	<ul style="list-style-type: none"> <li>• HALT mode</li> <li>• FmCF = 0 Hz (when oscillator stops).</li> <li>• FsXtal = 32.768 kHz for crystal oscillator.</li> <li>• System clock : RC oscillator</li> </ul>	4.5 to 6.0		400	1000	μA
	I <sub>DDHALT</sub> (5)			<ul style="list-style-type: none"> <li>• System clock : RC oscillator</li> </ul>	2.7 to 4.5		200	750	
	I <sub>DDHALT</sub> (6)			<ul style="list-style-type: none"> <li>• HALT mode</li> <li>• FmCF = 0 Hz (when oscillator stops).</li> <li>• FsXtal = 32.768 kHz for crystal oscillator.</li> <li>• System clock : 32.768 kHz</li> <li>• Internal RC oscillator stopped.</li> </ul>	4.5 to 6.0		25	100	
	I <sub>DDHALT</sub> (7)			<ul style="list-style-type: none"> <li>• Internal RC oscillator stopped.</li> </ul>	2.7 to 4.5		8	40	
Current drain at HOLD mode (Note 4)	I <sub>DDHOLD</sub> (1)	VDD	HOLD mode	4.5 to 6.0		0.05	30		
	I <sub>DDHOLD</sub> (2)			2.7 to 4.5		0.02	20		

(Note 4) The currents to output transistors and pull-up MOS transistors are ignored.



## LC865032A, 865028A, 865024A

Oscillation type	Supplier	Oscillator	C1	C2
12 MHz ceramic resonator oscillation	Murata	CSA12.0MTZ	33 pF	33 pF
		CST12.0MTW	On chip	
	Kyocera	KBR-12.0M	33 pF	33 pF
3 MHz ceramic resonator oscillation	Murata	CSA3.00MG040	100 pF	100 pF
		CST3.00MGW040	On chip	
	Kyocera	KBR-3.0MS	47 pF	47 pF

\* K rank ( $\pm 10\%$ ) and SL characteristics must be used for C1 and C2.

**Table 1. Ceramic Resonator Oscillation Guaranteed Constants (Main clock)**

Oscillation type	Supplier	Oscillator	C3	C4
32.768 kHz crystal oscillation	Kyocera	KF-38G-13P0200	18 pF	18 pF

\* J rank ( $\pm 5\%$ ) and CH characteristics must be used for C3 and C4.

(For applications which do not need high precision, use K rank ( $\pm 10\%$ ) and SL characteristics.)

**Table 2. Crystal Oscillation Guaranteed Constants (Sub-clock)**

- Notes
- Since the circuit pattern affects the oscillation frequency, place the oscillation-related parts as close to the oscillator pins as possible with the shortest pattern length.
  - If other oscillators are used, we provide no guarantee for the characteristics.

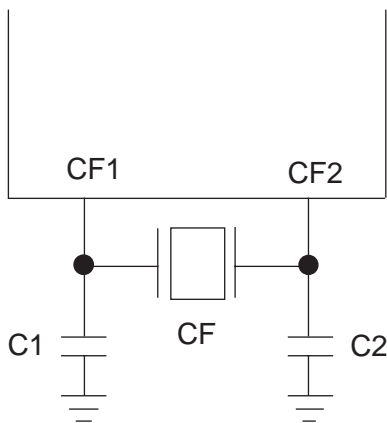

Main-clock circuit

**Figure 1 Ceramic Resonator Oscillator**

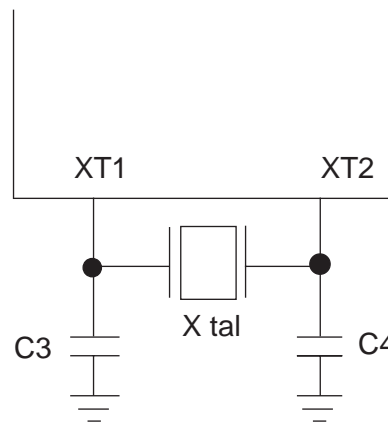

Sub-clock circuit

**Figure 2 Crystal Oscillator**

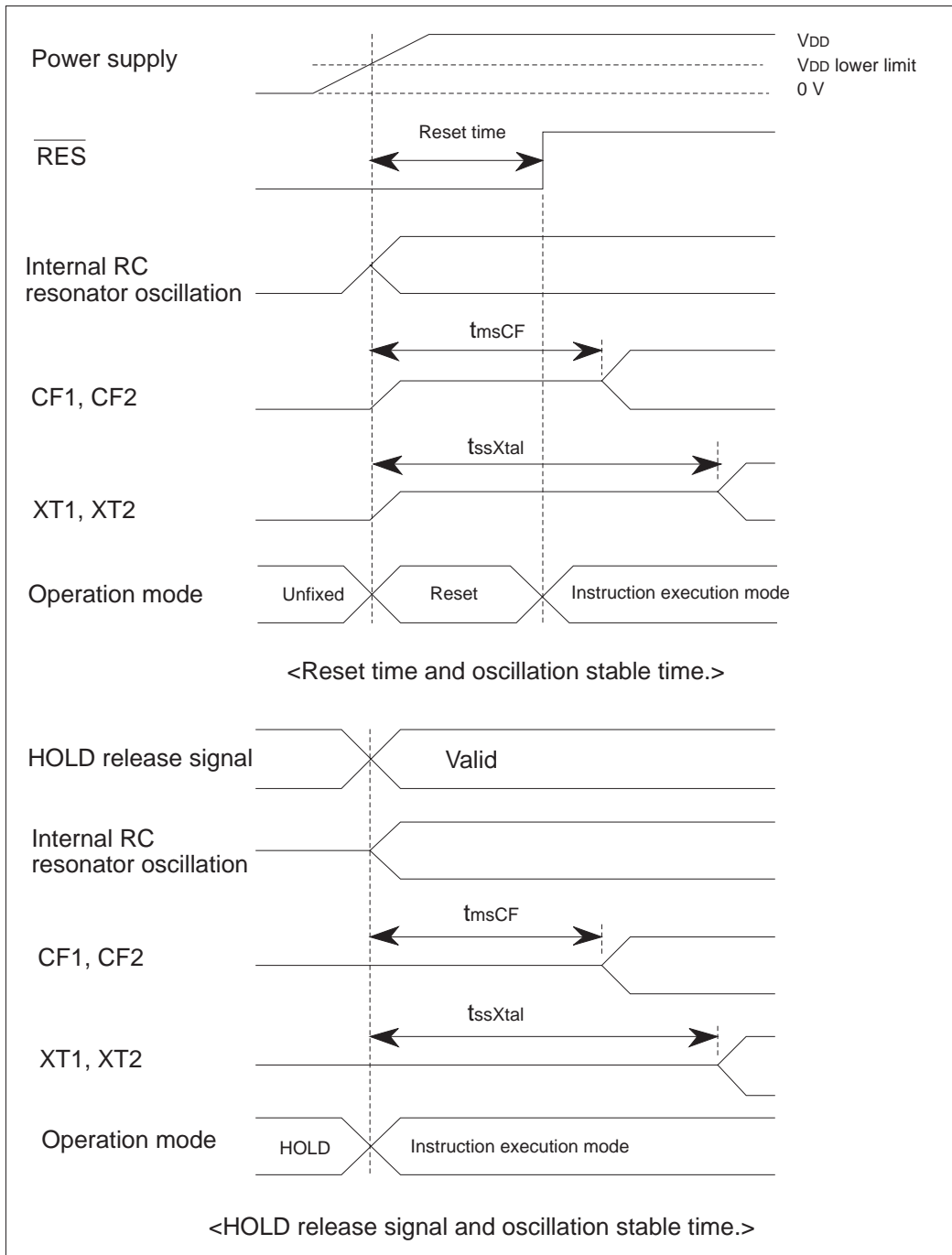
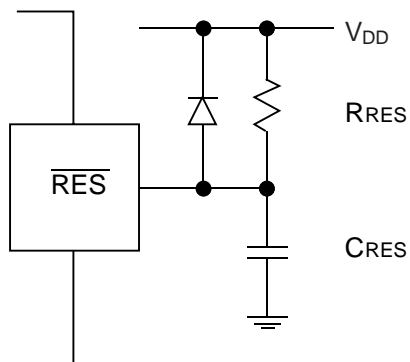

Figure 3 Oscillation Stable Time



(Note) Set the values of  $C_{RES}$ ,  $R_{RES}$  so that the reset time is 200  $\mu s$  or longer.

Figure 4 Reset Circuit

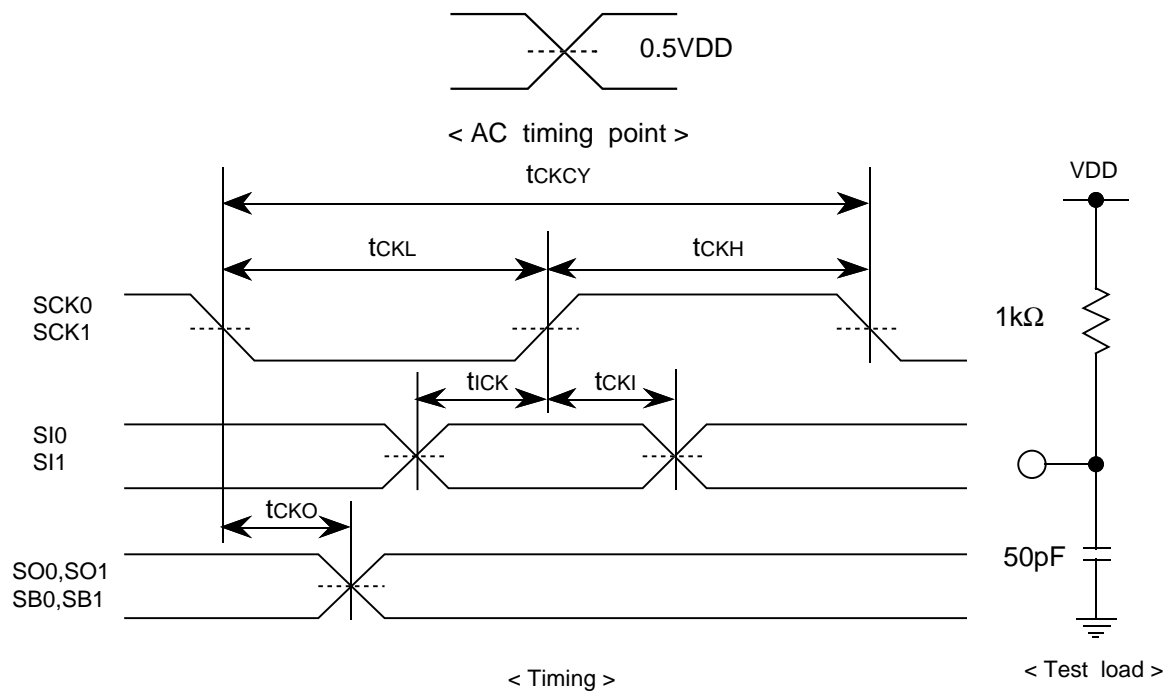

Figure 5 Serial Input/Output Test Conditions

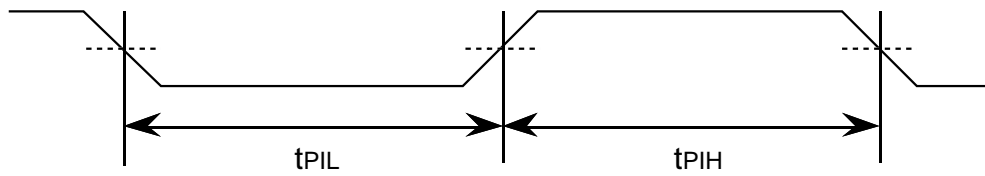

Figure 6 Pulse Input Timing Conditions

- Any and all SANYO products described or contained herein do not have specifications that can handle applications that require extremely high levels of reliability, such as life-support systems, aircraft's control systems, or other applications whose failure can be reasonably expected to result in serious physical and/or material damage. Consult with your SANYO representative nearest you before using any SANYO products described or contained herein in such applications.
- SANYO assumes no responsibility for equipment failures that result from using products at values that exceed, even momentarily, rated values (such as maximum ratings, operating condition ranges, or other parameters) listed in products specifications of any and all SANYO products described or contained herein.
- Specifications of any and all SANYO products described or contained herein stipulate the performance, characteristics, and functions of the described products in the independent state, and are not guarantees of the performance, characteristics, and functions of the described products as mounted in the customer's products or equipment. To verify symptoms and states that cannot be evaluated in an independent device, the customer should always evaluate and test devices mounted in the customer's products or equipment.
- SANYO Electric Co., Ltd. strives to supply high-quality high-reliability products. However, any and all semiconductor products fail with some probability. It is possible that these probabilistic failures could give rise to accidents or events that could endanger human lives, that could give rise to smoke or fire, or that could cause damage to other property. When designing equipment, adopt safety measures so that these kinds of accidents or events cannot occur. Such measures include but are not limited to protective circuits and error prevention circuits for safe design, redundant design, and structural design.
- In the event that any or all SANYO products(including technical data, services) described or contained herein are controlled under any of applicable local export control laws and regulations, such products must not be exported without obtaining the export license from the authorities concerned in accordance with the above law.
- No part of this publication may be reproduced or transmitted in any form or by any means, electronic or mechanical, including photocopying and recording, or any information storage or retrieval system, or otherwise, without the prior written permission of SANYO Electric Co., Ltd.
- Any and all information described or contained herein are subject to change without notice due to product/technology improvement, etc. When designing equipment, refer to the "Delivery Specification" for the SANYO product that you intend to use.
- Information (including circuit diagrams and circuit parameters) herein is for example only ; it is not guaranteed for volume production. SANYO believes information herein is accurate and reliable, but no guarantees are made or implied regarding its use or any infringements of intellectual property rights or other rights of third parties.