



LB8107M

Portable CD Player Actuator Driver

Overview

The LB8107M is a portable CD player mechanism actuator driver. It operates on a 2.4 V power supply, which corresponds to two rechargeable Ni-Cd cells.

Functions and Features

- Four H bridge driver channels on chip, one each for the four CD actuators; focus coil, tracking coil, spindle motor and sled motor
- Built-in step-up circuit to power the associated 5.0 V CD LSIs, including the DSP and microprocessor. (The drive transistor, L, Di and C are external components: step-up circuit) Io 150 mA, maximum
- Extremely low loss drive can be achieved, since the LB8107M detects the largest signal of the four drive channels and supplies that voltage to the H bridge driver blocks in each of the four channels using PWM voltage conversion. (The drive PNP transistor, L, Di and C are external components: step-down circuit)
- System start and stop can be performed at the microprocessor output.
- Support for switching between step drive mode, which has a high current reduction effect, and normal V control for the sled motor drive (The other three channels all are V type drive only.)
- Built-in battery check comparator
- Built-in integrating amplifier to handle the application of digital servo control to earlier spindle motors (This function integrates the PWM output.)
- A defect function is provided. This function improves the tracking ability by setting the voltage supplied to the H bridge drivers to the maximum in the presence of disk defects during playback.

Specifications

Absolute Maximum Ratings at Ta = 25°C

Parameter	Symbol	Conditions	Ratings	Unit
Maximum supply voltage	V _{CC} max		7.0	V
H bridge output current	I _{OUT}	Taking 400 mA/channel as the maximum.	800	mA
Step-up circuit output current	I _{CD}		150	mA
Allowable power dissipation	Pd max		800	mW
Operating temperature	T _{opr}		-25 to +75	°C
Storage temperature	T _{stg}		-40 to +125	°C

Package Dimensions

unit: mm

3148-QFP44MA

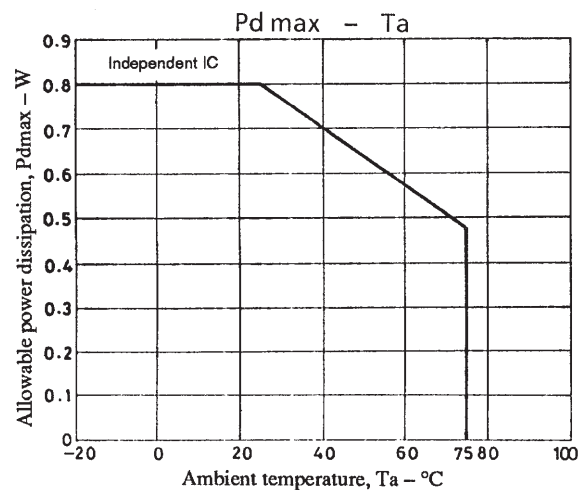
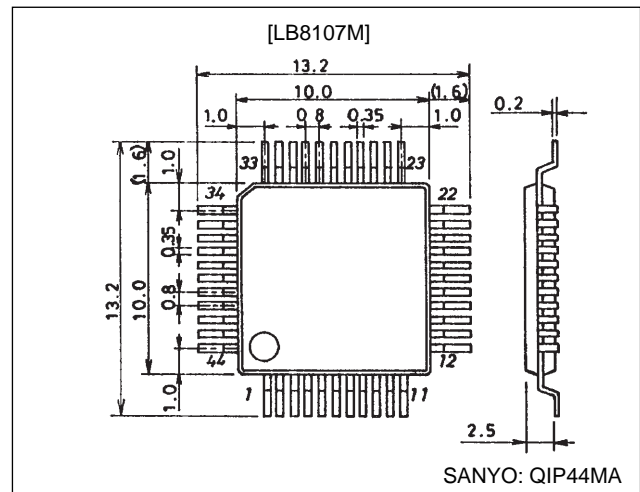

LB8107M

Allowable Operating Ranges at Ta = 25°C

Parameter	Symbol	Conditions	min	typ	max	Unit
Supply voltage	V _{CC}		2.0	2.4	4.0	V
Operating output				150		mW

Electrical Characteristics at Ta = 25°C, V_{CC} = 2.4 V

Parameter	Symbol	Conditions	min	typ	max	Unit
[Power Supply]						
Standby current drain	I _{CCO}	S/S1 = H, S/S2 = H			10	μA
Quiescent current	I _{CC}			18	27	mA
[Step-up Circuit]						
Output voltage	V _{CD}		4.75	5.0	5.25	V
NPN transistor drive current	I _{no}			3.0		mA
Load characteristics	ΔV _{CD} /I _{CD}				0.01	%/mA
Voltage characteristics	ΔV _{CD} /V _{CC}				100	mV/V
Minimum off duty				50		%
[Oscillator Circuit]						
Synchronization signal input frequency	F _{svync}		80		100	kHz
[H Bridge Outputs]						
Saturation voltage	V _{CC (sat)}	200 mA, TOP + BOTTOM		0.26	0.39	V
[Motor Control Block]						
Input voltage	V _{IN}	The linear region where V _{REF1} = 1/2 V _{CD}	V _{REF1} - 1.0	V _{REF1}	V _{REF1} + 1.0	V
Input bias current	I _{BDR}			1.0		μA
Transmission gain (+)	G _{VTR}			7.95		dB
Transmission gain ratio (+)/(-)	ΔG _{VTR}	Within the same channel		±1		dB
Input dead band voltage	V _{dz}				V _{REF1} + 100	mV
Input dead band voltage offset	V _{dzof}	At the forward/reverse transition within a channel			±10	mV
[PWM]						
Maximum output voltage	V _{OUT}		2.1	2.4	2.7	V
PNP transistor drive current	I _{pi}	*		V _{OUT} /600		mA
Load characteristics	ΔV _{OUT} /I _{rd}				0.03	%/mA
Voltage characteristics	ΔV _{OUT} /V _{CC}				50	mV/V
[Sled Drive Circuit]						
Drive Reference Voltage (step mode)	V _{REFO}			V _{REF1} + 0.65		V
SLS on voltage	V _{SLS ON}		2.0			V
SLL input bias current	I _{BSLL}				300	μA
SLH input bias current	I _{BSLH}				300	μA
Defect voltage	V _{DEF ON}		2.0			V
[S/S Pins 1 and 2]						
P-on voltage					V _{CC} - 1.0	V
P-off voltage			V _{CC} - 0.5			V
[Reference Voltage Pin]						
Output current	I _{REFO}				100	μA
Output voltage	V _{REF2}			1.2		V
[WP Pin]						
Output voltage	V _{OPW}		V _{CD1} - 0.15			V
[Battery Check Block]						
BI input bias current	I _{BBI}				1.5	μA
BO output voltage	V _{OBO}	I _{OBO} = 500 μA			0.3	V

Note: * This is a design guarantee and is not measured.

Continued on next page.

LB8107M

Continued from preceding page.

Parameter	Symbol	Conditions	min	typ	max	Unit
[CLK Block]						
CLK input voltage	V_{CLK}		2			V
[Oscillator Block]						
Oscillator power voltage	V_{OSCP}		$V_{CC} - 0.15$			V
OSC pin input bias current	I_{BOSC}				-1.5	μA
[Integrating Amplifier Block]						
Input bias current	I_{BIAI}				500	nA
First stage amplifier gain	GV1	Open loop, $f = 1 \text{ kHz}^*$		55		dB
Second stage amplifier gain	GV2	Internal closed loop		0		dB
First stage output saturation voltage	V_{O1-1}	1 mA SOURCE	$V_{CD} - 1.3$			V
	V_{O1-2}	1 mA SINK			1.3	V
Second stage output saturation voltage	V_{O2-1}	1 mA SOURCE	$V_{CD} - 1.3$			V
	V_{O2-2}	1 mA SINK			1.3	V

Note: * This is a design guarantee and is not measured.

Pin Assignment

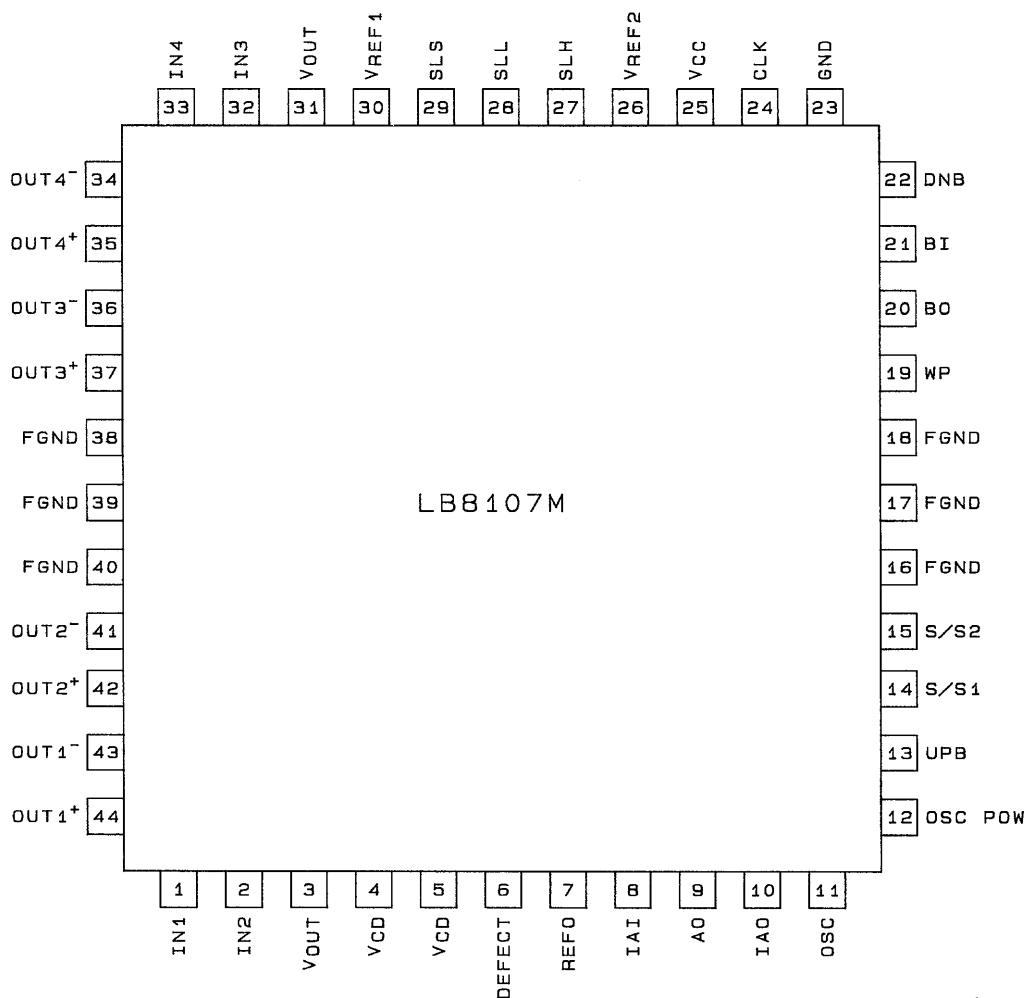

A02435

Top view

LB8107M

Pin Functions

Unit (resistance: Ω)

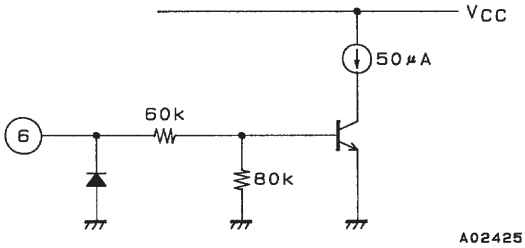
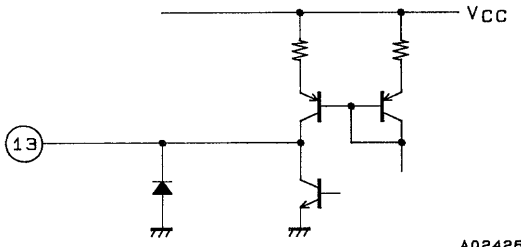
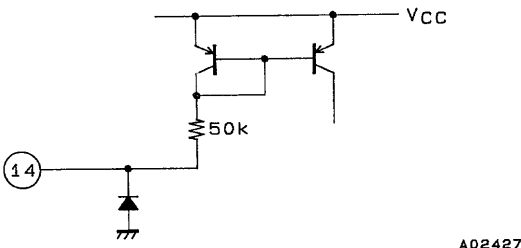
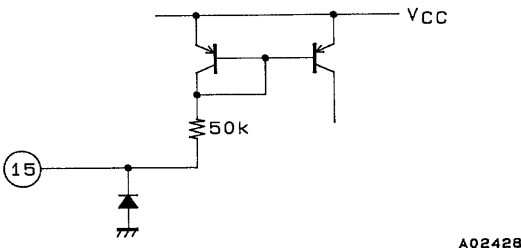
Pin No.	Symbol	I/O	Pin function
1	IN1	I	Actuator control input: focus
2	IN2	I	Actuator control input: tracking
3, 31	V _{OUT}		Power supply for the four H bridge channels
4, 5	V _{CD}	I	Step-up circuit output voltage
6	DEFECT	I	<p>Sets V_{OUT} to its maximum voltage on defect input.</p>  <p style="text-align: right;">A02425</p>
7	REFO	O	Sled drive reference voltage
8	IAI		Integrating amplifier input
9	AO	O	Inverting amplifier output
10	IAO		Integrating amplifier output
11	OSC		Free-running oscillator: RC circuit connection
12	OSCPow	O	Free-running oscillator: RC circuit power supply
13	UPB	O	<p>Step-up npn transistor drive output</p>  <p style="text-align: right;">A02426</p>
14	S/S1	I	<p>Starts the system when a low level is applied as the LB8107M start input (power on lock from the microprocessor)</p>  <p style="text-align: right;">A02427</p>
15	S/S2	I	<p>Provides a logical or function with the S/S1 input (for starting from a switch input)</p>  <p style="text-align: right;">A02428</p>

Continued on next page.

LB8107M

Continued from preceding page.

Unit (resistance: Ω)

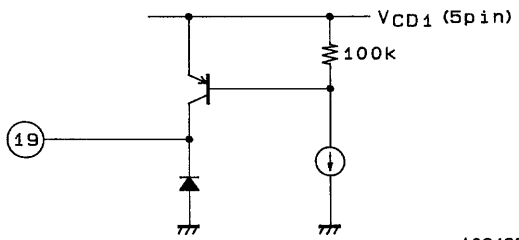
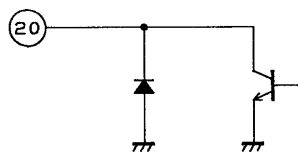
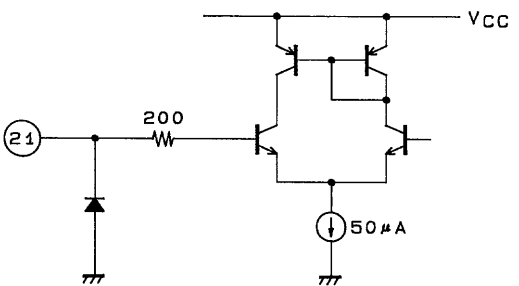
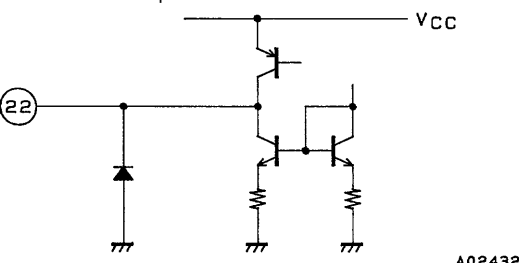
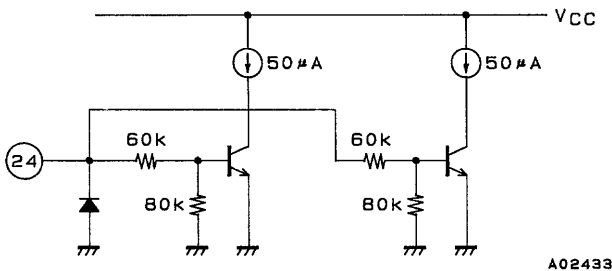
Pin No.	Symbol	I/O	Pin function
16, 17, 18, 38, 39, 40	FGND		Ground for the power block
19	WP	O	Microprocessor start-up output linked to S/S2. pnp open collector output  <p style="text-align: right;">A02429</p>
20	BO	O	Battery low output. npn open collector output; Low: battery low  <p style="text-align: right;">A02430</p>
21	BI	I	Battery voltage detection pin  <p style="text-align: right;">A02431</p>
22	DNB	O	Voltage reduction pnp transistor drive output  <p style="text-align: right;">A02432</p>
23	GND		Signal ground
24	CLK	I	External clock input pin  <p style="text-align: right;">A02433</p>
25	V _{CC}		Power supply: 2.0 to 4.0 V
26	V _{REF2}		Reference voltage: 1.2 V
27	SLH	I	Sled drive starting voltage adjustment

Continued on next page.

LB8107M

Continued from preceding page.

Unit (resistance: Ω)

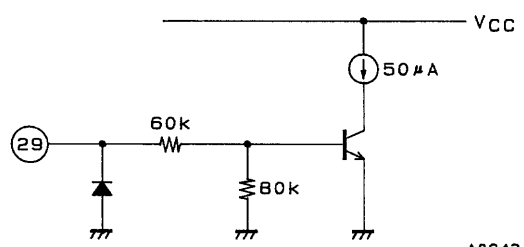
Pin No.	Symbol	I/O	Pin function
28	SLL	I	Sled drive stop voltage adjustment
29	SLS	I	Sled switching 
30	V _{REF1}	I	Motor control block input reference voltage: supplied from the CD servo IC
32	IN3	I	Actuator control input: Spindle
33	IN4	I	Actuator control input: Sled
34	OUT4 (-)	O	Actuator control output (-): Sled
35	OUT4 (+)	O	Actuator control output (+): Sled
36	OUT3 (-)	O	Actuator control output (-): Spindle
37	OUT3 (+)	O	Actuator control output (+): Spindle
41	OUT2 (-)	O	Actuator control output (-): Tracking
42	OUT2 (+)	O	Actuator control output (+): Tracking
43	OUT1 (-)	O	Actuator control output (-): Focus
44	OUT1 (+)	O	Actuator control output (+): Focus

Functional Description

1. Actuator drivers (focus, tracking, spindle and sled)

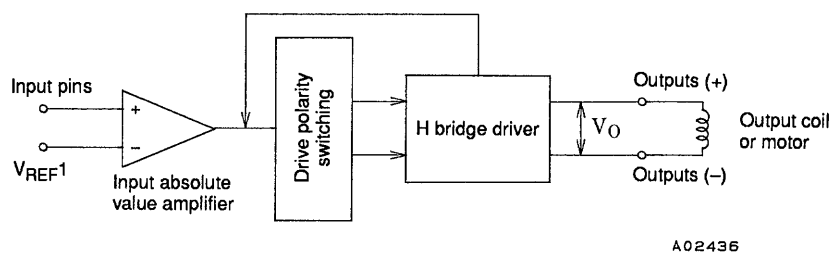

V_{REF1} is supplied from the CD DSP that is powered by the stepped-up voltage (5.0 V) created by the LB8107M. (Normally, V_{REF1} will be 1/2 V_{CD2}.)

The figure below shows the form of the I/O transmission characteristics.

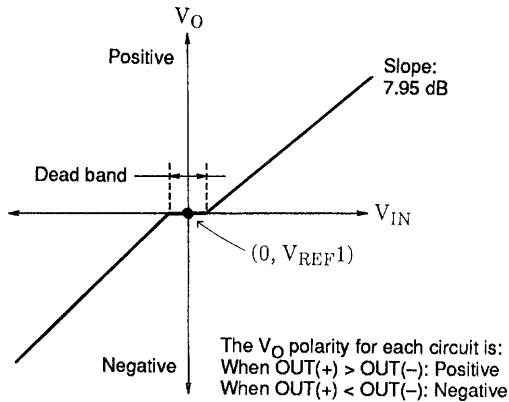

That is, the LB8107M implements a polarity reversing V-type drive with respect to the input signals (from the DSP) referenced to V_{REF1} .

The transmission gain $\Delta V_O/\Delta V_{IN}$ is 7.95 (typical) and the LB8107M provides a region (dead band) around V_{REF1} where the output does not change with the input. (The dead band is $V_{REF1} \pm 100$ mV (maximum).)

The LB8107M provides excellent gain precision since the a feedback structure is adopted in the drive circuits.

2. Sled motor step drive switching (selected when the SLS pin is low)

While it goes without saying that the V-type drive described above can be used for sled motor drive, the LB8107M also supports a step drive scheme to reduce sled motor drive power.

Since a signal that is generated by integrating the tracking output is usually used as the sled motor control input, step drive attempts to drive the sled motor only during certain periods by providing a sled motor start command from the sled motor control input and a sled motor stop command from the tracking control input.

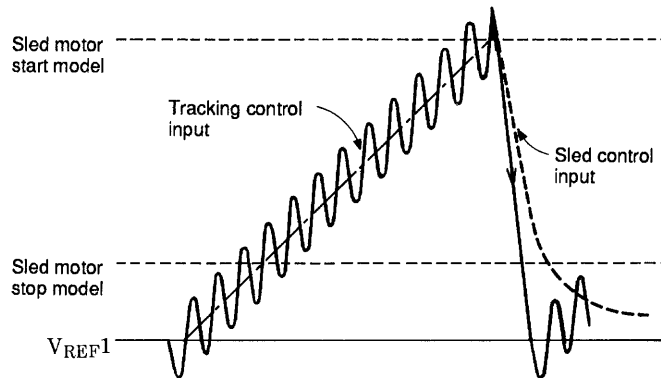

The start and stop levels are set by an external resistor connected between the V_{REF1} pin and the REFO pin.

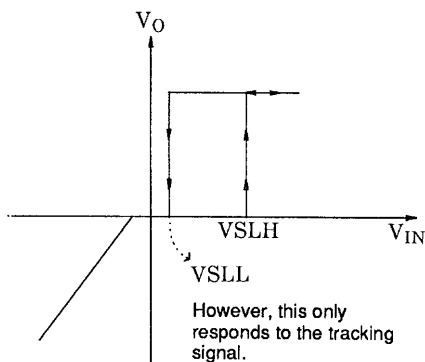

Note that for inputs that are lower than V_{REF1} this system operates normally regardless of the SLS pin.

Also, as will be discussed later, the maximum voltage is supplied to the H bridge in step drive mode.

3. Step-up Circuit

The step-up circuit can be used to power not only the four driver channel control stages, but also external circuits. (V_{DD} is 5.0 V (typical) with an I_o of 150 mA (maximum).)

This step-up circuit operates from the built-in oscillator's free-running mode immediately after the system is started.

(The frequency is determined by the RC circuit connected to the OSCP* pin. When C is 400 pF and R is 30 k Ω , the frequency will be about 80 kHz.)

Note: * This pin is used for current pass prevention in standby mode.

After the system is started, (to bring up the CD DSP and other circuits) when a clock with a frequency (e.g., $2f_c = 88.2$ kHz) greater than the free-running frequency is input to the CLK pin, the oscillator synchronizes with the input clock. \rightarrow frequency only synchronization. (Since the frequency range is from 80 to 100 kHz, 88.2 kHz is optimal as the input frequency.)

Since the on/off duty ratio is set to have a maximum of 50%, i.e., the on period ranges from 0 to 50%, this provides a protection function for the output transistors when large loads are applied. (We strongly recommend using output transistors with an h_{FE} as large as possible. Also, for efficiency, we recommend using Schottky diodes.)

4. PWM Power Supply Scheme

To improve power efficiency as much as possible in the LB8107M, maximum value output PWM voltage conversion is used in the power supply for each of the four H bridge driver channels.

5. The maximum value of the control block outputs (the outputs of the absolute value amplifiers with respect to their inputs) for each of the drivers is detected, and a voltage consisting of that voltage plus a margin (the offset) is supplied to the H bridge for each channel using PWM voltage conversion (step-down converter). (This allows the actuators to be driven with the minimum power in cases such as, for example, when the operating voltages for all four actuator channels are identical and small.) Unlike schemes in which a PWM converter is provided for each channel, only one L/C pair is required, and furthermore, since the actuator drive is linear, this scheme does not generate the noise levels associated with direct PWM schemes. Also, since the voltage supplied to the H bridges by this PWM scheme is limited to 2.4 V (typical), there are no changes in the maximum currents supplied to the actuators associated with changes in the power supply voltage used. Furthermore, this scheme is designed so that the maximum voltage is supplied when the defect signal from the DSP, which indicates the presence of defects, is high or when in sled motor step drive mode.

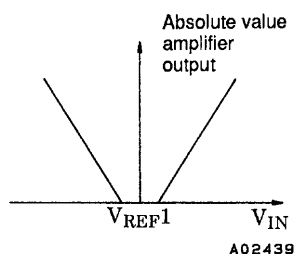

6. System Start and Stop Commands

The LB8107M is designed so that the system can be started and stopped by the control microprocessor.

[Start]

The pins S/S1 and S/S2 are provided as system startup pins. Of these, S/S1 locks the system power supply when it is set low by the microprocessor as a power on lock. S/S2 is provided to be used for startup from a switch and the function operates by taking the logical with S/S1. However, the microprocessor can still apply the S/S1 power on lock by reading the WP (wake up) pin output, since this output is goes high when S/S2 is low.

[Stop]

The system power supply can be shut down by setting both S/S1 and S/S2 high. This puts the LB8107M in standby mode.

[Other notes]

- Circuit blocks that use V_{CD1} as the power supply
Integrating amplifier, inverting amplifier, sled switching circuit (including SLS, SLH and SLL) and the maximum value circuit
- Circuit blocks that use V_{CC} as the power supply
Step-up circuit, step-down circuit, reference voltage, battery check, oscillator, edge start and other circuits.

LB8107M

Sample Application Circuit

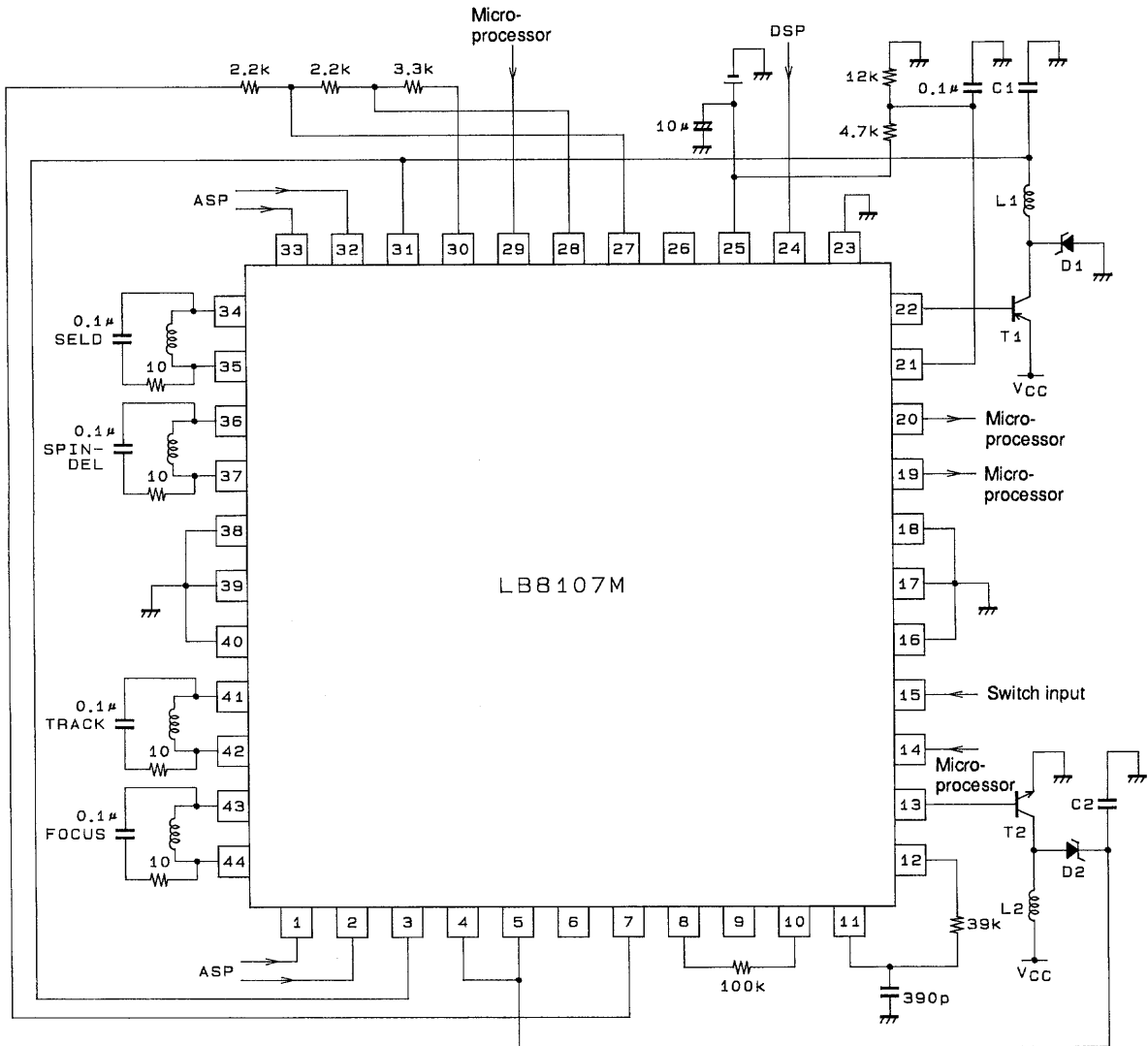

A02440

Unit (resistance: Ω, capacitance: F)

- T12SB815
- T22SC3650
- D1 = D2SB07-03C
- L1 = L2.....30 µH
- C1 = C2100 µF

To control the spindle motor using a digital servo scheme, input the PWM output to pin 8, set up the external integration constant, and input the output from pin 9 to the spindle input.

Internal Equivalent Circuit

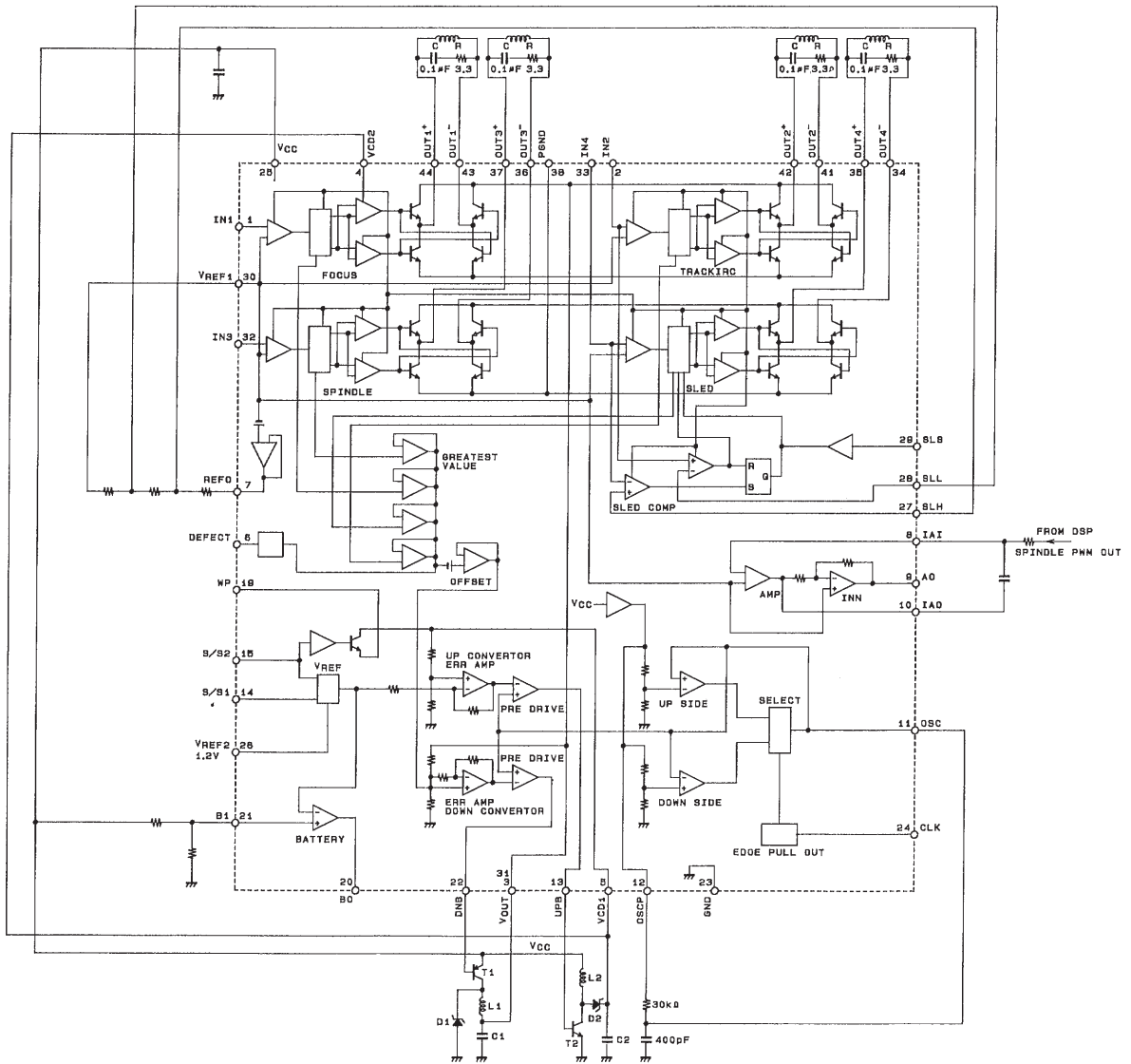

A02441

Reference values

- T12SB815
- T22SC3650
- D1 = D2SB07-03C
- L1 = L230 μH (under 1.35 Ω, 600 mA)
- C1 = C2100 μF

Unit (resistance: Ω)

- No products described or contained herein are intended for use in surgical implants, life-support systems, aerospace equipment, nuclear power control systems, vehicles, disaster/crime-prevention equipment and the like, the failure of which may directly or indirectly cause injury, death or property loss.
- Anyone purchasing any products described or contained herein for an above-mentioned use shall:
 - ① Accept full responsibility and indemnify and defend SANYO ELECTRIC CO., LTD., its affiliates, subsidiaries and distributors and all their officers and employees, jointly and severally, against any and all claims and litigation and all damages, cost and expenses associated with such use:
 - ② Not impose any responsibility for any fault or negligence which may be cited in any such claim or litigation on SANYO ELECTRIC CO., LTD., its affiliates, subsidiaries and distributors or any of their officers and employees jointly or severally.
- Information (including circuit diagrams and circuit parameters) herein is for example only; it is not guaranteed for volume production. SANYO believes information herein is accurate and reliable, but no guarantees are made or implied regarding its use or any infringements of intellectual property rights or other rights of third parties.

This catalog provides information as of July, 1998. Specifications and information herein are subject to change without notice.