



# SANYO Semiconductors DATA SHEET

## LB11988HR — Monolithic Digital IC Fan Motor Driver

### Overview

The LB11988HR is a motor driver IC optimal for driving the automotive fan motors.

### Features

- 3-Phase full-wave current-linear drive system.
- Current limiter circuit built in.
- Output stage upper/lower over-saturation prevention circuit built in.
- Forward/backward rotation direction setting circuit built in.
- FG amplifier built in.
- Thermal shutdown circuit built in.

### Absolute Maximum Ratings at Ta = 25°C

Parameter	Symbol	Conditions	Ratings	Unit
Maximum supply voltage	V <sub>CC</sub> max		24	V
	V <sub>S</sub> max		24	V
Maximum output current	I <sub>O</sub> max		1.3	A
Allowable power dissipation	P <sub>d</sub> max	Independent IC	0.8	W
Operating temperature range	T <sub>opr</sub>		-40 to +85	°C
Storage temperature range	T <sub>stg</sub>		-55 to +150	°C

### Allowable Operating Range at Ta = 25°C

Parameter	Symbol	Conditions	Ratings	Unit
Supply voltage	V <sub>S</sub>		5 to 22	V
	V <sub>CC</sub>		5 to 22	
Hall input amplitude	V <sub>HALL</sub>	Between hall inputs	±30 to ±80	mVo-p

■ Any and all SANYO Semiconductor products described or contained herein do not have specifications that can handle applications that require extremely high levels of reliability, such as life-support systems, aircraft's control systems, or other applications whose failure can be reasonably expected to result in serious physical and/or material damage. Consult with your SANYO Semiconductor representative nearest you before using any SANYO Semiconductor products described or contained herein in such applications.

■ SANYO Semiconductor assumes no responsibility for equipment failures that result from using products at values that exceed, even momentarily, rated values (such as maximum ratings, operating condition ranges, or other parameters) listed in products specifications of any and all SANYO Semiconductor products described or contained herein.

**SANYO Semiconductor Co., Ltd.**

TOKYO OFFICE Tokyo Bldg., 1-10, 1 Chome, Ueno, Taito-ku, TOKYO, 110-8534 JAPAN

# LB11988HR

**Electrical Characteristics** at Ta = 25°C, VCC = 12V, VS = 12V

Parameter	Symbol	Conditions	Ratings			unit
			min	typ	max	
VCC supply current	ICC	RL = 560Ω (Y)		15	24	mA
Output						
Output saturation voltage	VOsat1	IO = 500mA, Rf = 0.5Ω, Sink+Source (with saturation prevention)		2.1	2.6	V
	VOsat2	IO = 1.0A, Rf = 0Ω, Sink+Source (with saturation prevention)		2.6	3.5	
Output leakage current	Ioleak				1.0	mA
Hall amplifier						
Input offset voltage	Voff(HALL)		-6		+6	mV
Input bias current	Ib(HALL)	VIN, WIN		1	3	μA
Common-mode input voltage	Vcm1(HALL)	VCC = VS = 12V	3		VCC-3	V
	Vcm2(HALL)	VCC = VS = 5V	1.5		VCC-1.5	
FR						
Threshold voltage	VFRTH		4		8	V
Input bias current	Ib(FR)		-5			μA
Current limit						
LIM pin current limit level	ILIM	Rf = 0.5Ω, Hall input logic fixed (U, V, W = H, H, L)		1		A
Saturation						
Saturation prevention circuit lower set voltage	VOsat(DET)	RL = 560Ω (Y), Rf = 0.5Ω Voltage between each OUT and RF		0.28		V
FG Amplifier						
Output "High" voltage	Vfgoh(SH)		11.8			V
Output "Low" voltage	Vfgol(SH)				0.3	
Hysteresis width	Vhys			23		mV
TSD operating temperature	TTSD	Design target value*		170		°C

\*: T-TSD is not measured because it stands for design target.

## Package Dimensions

unit : mm

3233B

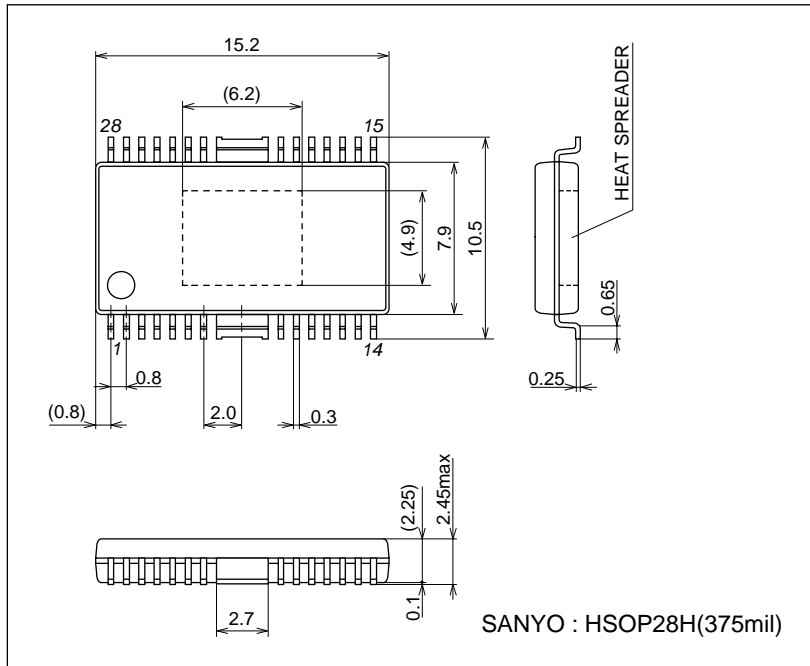

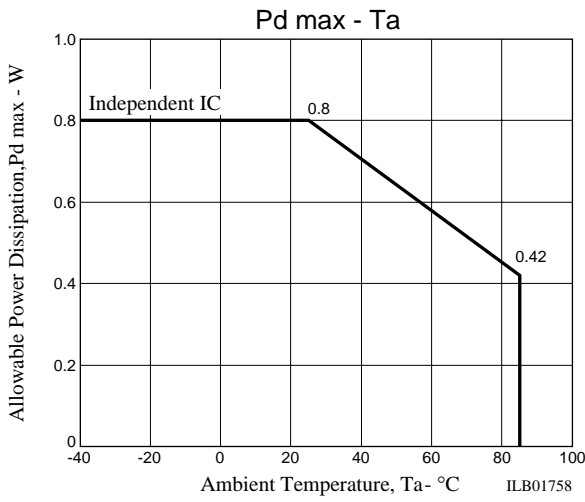

**Truth Table and Control Function**

	Source → Sink	Hall Input			FR
		U	V	W	
1	V → W	H	H	L	H
	W → V				L
2	U → W	H	L	L	H
	W → U				L
3	U → V	H	L	H	H
	V → U				L
4	W → V	L	L	H	H
	V → W				L
5	W → U	L	H	H	H
	U → W				L
6	V → U	L	H	L	H
	U → V				L

Note: “H” in the FR column represents a voltage of 8V or more. “L” represents a voltage of 4V or less. (At V<sub>CC</sub>=12V)

Note: “H” under the Hall Input columns represents a state in which “+” has a potential which is higher by 0.01V or more than that of the “-” phase inputs. Conversely “L” represents a state in which “+” has a potential which is lower by 0.01V or more than that of the “-” phase inputs.

Note: Since a 180° energized system is used as a drive system, other phases than the sink and source are not OFF.

# LB11988HR

## Pin Assignment

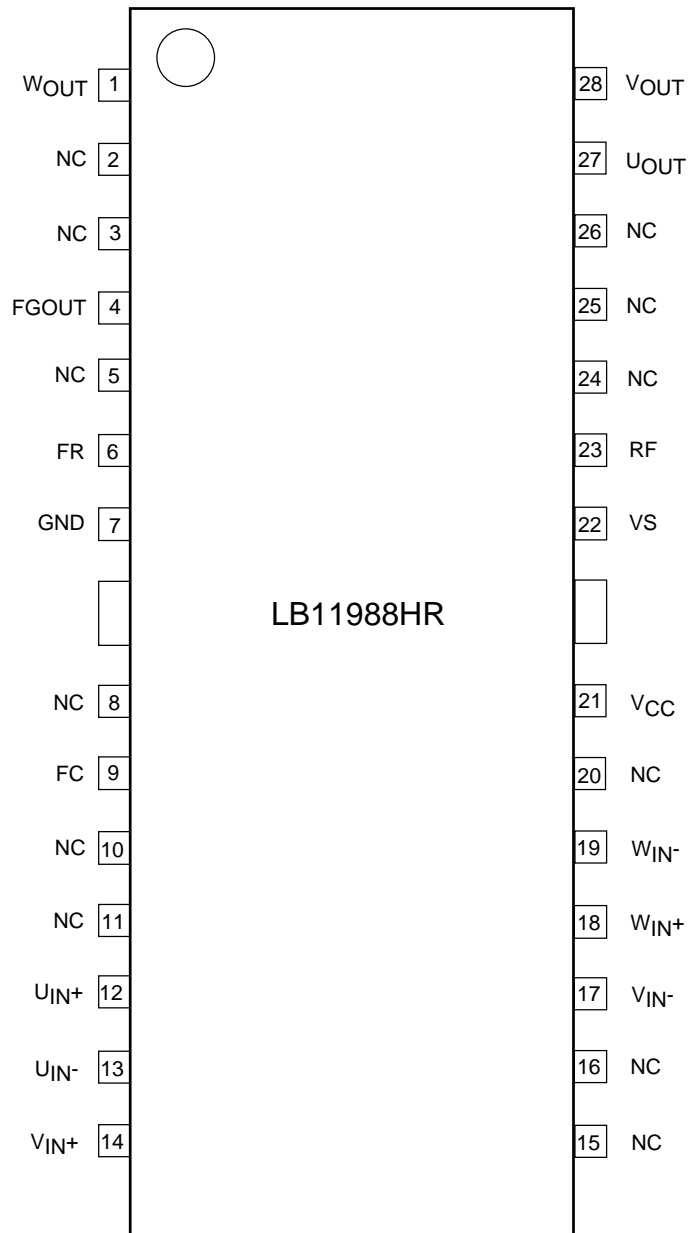

Top view

Pin Functions

Pin Name	Pin No.	Input/Output Equivalent Circuit	Pin Functions
VCC	21		Power supply pin for supplying power to all circuits except output section in IC; this voltage must be stabilized so as to eliminate ripple and noise.
GND	7		GND for others than the output transistor.
	FRAME		Minimum potential of output transistor is at RF pin.
U <sub>IN+</sub> , U <sub>IN-</sub>	12,13		U-phase Hall device input pin; logic "H" presents IN+>IN-
V <sub>IN+</sub> , V <sub>IN-</sub>	14,17		V-phase Hall device input pin; logic "H" presents IN+>IN-
W <sub>IN+</sub> , W <sub>IN-</sub>	18,19		W-phase Hall device input pin; logic "H" presents IN+>IN-
U <sub>OUT</sub> V <sub>OUT</sub> W <sub>OUT</sub>	27 28 1		U-phase output pin. V-phase output pin. W-phase output pin. (Built-in spark killer diode)
RF	23		Output current detection pin. Connecting R <sub>f</sub> between this pin and GND activates current limiting circuit. Then the lower over-saturation prevention circuit is activated in accordance with this pin voltage. Since the over-saturation prevention level is set with this voltage, the lower over-saturation prevention effect may deteriorate in the high current range if the R <sub>f</sub> value is reduced to an extremely low level.
VS	22		Power supply pin for supplying power to output section in IC.
FR	6		Forward/Reverse switching pin.

Continued on next page.

# LB11988HR

Continued from preceding page.

Pin Name	Pin No.	Input/Output Equivalent Circuit	Pin Functions
FC	9		<p>Frequency characteristics compensation pin for over-saturation prevention circuit loop.</p>
FGOUT	4		<p>FG amplifier output pin. Resistive load provided internally.</p>

Block Diagram

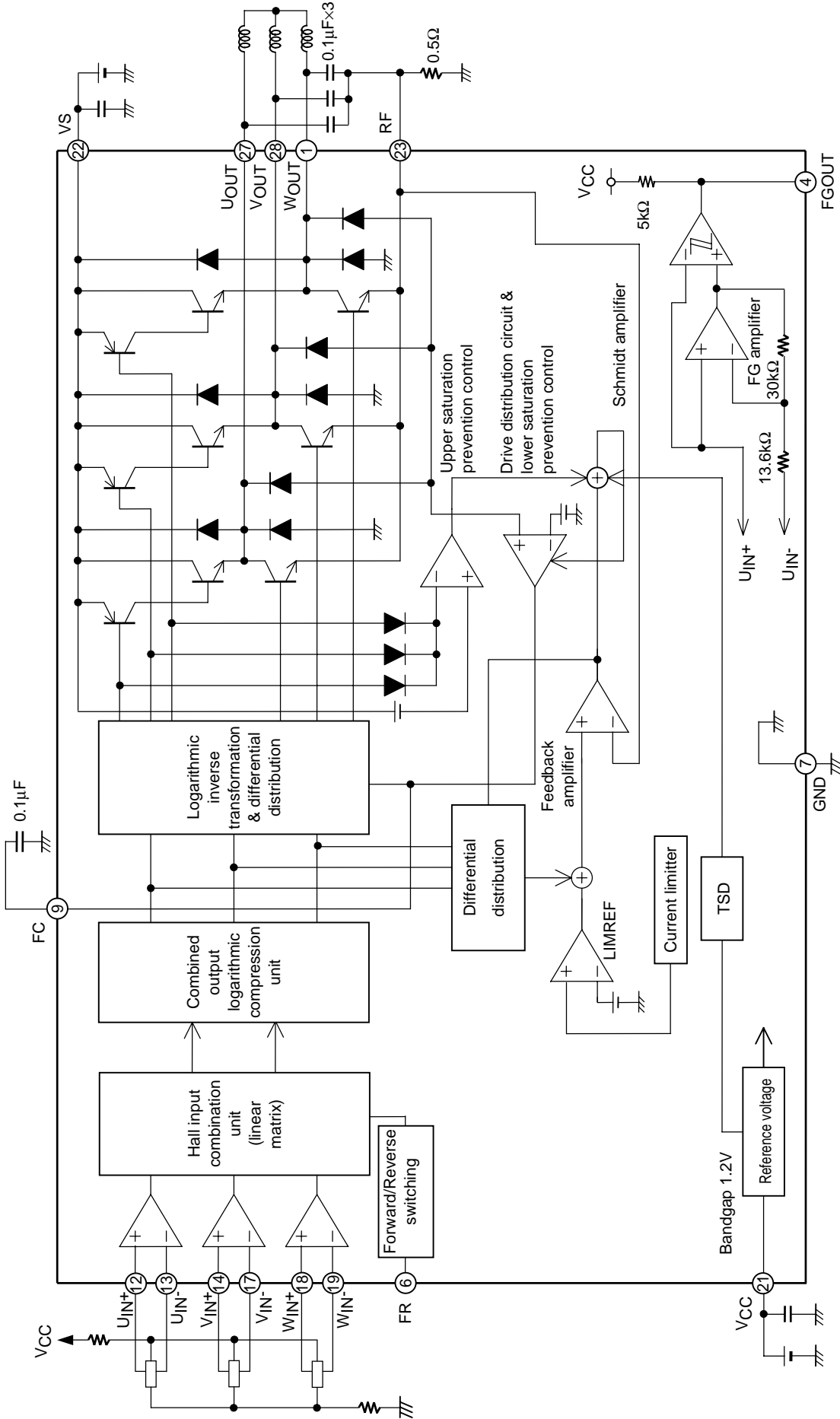

- Specifications of any and all SANYO Semiconductor products described or contained herein stipulate the performance, characteristics, and functions of the described products in the independent state, and are not guarantees of the performance, characteristics, and functions of the described products as mounted in the customer's products or equipment. To verify symptoms and states that cannot be evaluated in an independent device, the customer should always evaluate and test devices mounted in the customer's products or equipment.
- SANYO Semiconductor Co., Ltd. strives to supply high-quality high-reliability products. However, any and all semiconductor products fail with some probability. It is possible that these probabilistic failures could give rise to accidents or events that could endanger human lives, that could give rise to smoke or fire, or that could cause damage to other property. When designing equipment, adopt safety measures so that these kinds of accidents or events cannot occur. Such measures include but are not limited to protective circuits and error prevention circuits for safe design, redundant design, and structural design.
- In the event that any or all SANYO Semiconductor products (including technical data, services) described or contained herein are controlled under any of applicable local export control laws and regulations, such products must not be exported without obtaining the export license from the authorities concerned in accordance with the above law.
- No part of this publication may be reproduced or transmitted in any form or by any means, electronic or mechanical, including photocopying and recording, or any information storage or retrieval system, or otherwise, without the prior written permission of SANYO Semiconductor Co., Ltd.
- Any and all information described or contained herein are subject to change without notice due to product/technology improvement, etc. When designing equipment, refer to the "Delivery Specification" for the SANYO Semiconductor product that you intend to use.
- Information (including circuit diagrams and circuit parameters) herein is for example only; it is not guaranteed for volume production. SANYO Semiconductor believes information herein is accurate and reliable, but no guarantees are made or implied regarding its use or any infringements of intellectual property rights or other rights of third parties.

This catalog provides information as of May, 2006. Specifications and information herein are subject to change without notice.