

10/100 Mbps TX/FX/10BT Fast Ethernet Physical Layer Device (PHY)

Features

- Single-Chip 100BASE-TX/FX/10BASE-T Fast Ethernet Physical Layer Solution
- Dual-Speed - 10/100 Mbps/sec
- Half-Duplex And Full-Duplex Support
- MII Interface to Ethernet Controller
- MI Interface for Configuration and Status
- Optional Repeater Interface
- AutoNegotiation: 10/100, Full/Half-Duplex
- Meets All Applicable IEEE 802.3 Standards
- On-Chip Wave Shaping - No External Filters Required
- Adaptive Equalizer
- Baseline Wander Correction
- Interface to External 100BASE-T4 PHY
- LED Outputs
 - Link
 - Activity
 - Collision
 - Full Duplex
 - 10/100
 - User-Programmable
- Many User Features and Options
- Few External Components
- 3.3V Supply with 5V-Tolerant I/O
- 64-Pin TQFP Package (1.4-mm Body Thickness)

GENERAL DESCRIPTION

The SMSC LAN83C183 is a highly integrated analog interface IC for twisted pair Ethernet applications. The LAN83C183 can be configured for either 100-Mbps (100BASE-TX or 100 BASE-FX) or 10-Mbps (10BASE-T) Ethernet operation. The 100BASE-FX is packaged in a 64-Pin TQFP package.

The LAN83C183 consists of a 4B5B/Manchester encoder/decoder, scrambler/descrambler, transmitter with wave shaping and output driver, twisted pair receiver with on-chip equalizer and baseline wander correction, clock and data recovery, AutoNegotiation, controller interface (MII), and serial port (MI).

The addition of internal output waveshaping circuitry and on-chip filters eliminates the need for external filters normally required in 100BASE-TX and 10BASE-T applications.

The LAN83C183 can automatically configure itself for 100- or 10-Mbps and full- or half-duplex operation with the on-chip AutoNegotiation algorithm.

The eleven 16-bit registers of the LAN83C183 can be accessed through the Management Interface (MI) serial port. These registers contain configuration inputs, status outputs, and device capabilities.

The LAN83C183 is ideal as a media interface for 100BASE-TX/10BASE-T adapter cards, PC Cards, motherboards, mobile applications, repeaters, switching hubs, and external PHYs.

The LAN83C183 operates from a single 3.3V supply. All inputs and outputs are 5V-tolerant and can directly interface to other 5V devices.

ORDERING INFORMATION

Order Number:
LAN83C183-JD
64-Pin TQFP Package



80 Arkay Drive
Hauppauge, NY 11788
(631) 435-6000
FAX (631) 273-3123

Copyright © SMSC 2004. All rights reserved.

Circuit diagrams and other information relating to SMSC products are included as a means of illustrating typical applications. Consequently, complete information sufficient for construction purposes is not necessarily given. Although the information has been checked and is believed to be accurate, no responsibility is assumed for inaccuracies. SMSC reserves the right to make changes to specifications and product descriptions at any time without notice. Contact your local SMSC sales office to obtain the latest specifications before placing your product order. The provision of this information does not convey to the purchaser of the described semiconductor devices any licenses under any patent rights or other intellectual property rights of SMSC or others. All sales are expressly conditional on your agreement to the terms and conditions of the most recently dated version of SMSC's standard Terms of Sale Agreement dated before the date of your order (the "Terms of Sale Agreement"). The product may contain design defects or errors known as anomalies which may cause the product's functions to deviate from published specifications. Anomaly sheets are available upon request. SMSC products are not designed, intended, authorized or warranted for use in any life support or other application where product failure could cause or contribute to personal injury or severe property damage. Any and all such uses without prior written approval of an Officer of SMSC and further testing and/or modification will be fully at the risk of the customer. Copies of this document or other SMSC literature, as well as the Terms of Sale Agreement, may be obtained by visiting SMSC's website at <http://www.smisc.com>. SMSC is a registered trademark of Standard Microsystems Corporation ("SMSC"). Product names and company names are the trademarks of their respective holders.

SMSC DISCLAIMS AND EXCLUDES ANY AND ALL WARRANTIES, INCLUDING WITHOUT LIMITATION ANY AND ALL IMPLIED WARRANTIES OF MERCHANTABILITY, FITNESS FOR A PARTICULAR PURPOSE, TITLE, AND AGAINST INFRINGEMENT AND THE LIKE, AND ANY AND ALL WARRANTIES ARISING FROM ANY COURSE OF DEALING OR USAGE OF TRADE.

IN NO EVENT SHALL SMSC BE LIABLE FOR ANY DIRECT, INCIDENTAL, INDIRECT, SPECIAL, PUNITIVE, OR CONSEQUENTIAL DAMAGES; OR FOR LOST DATA, PROFITS, SAVINGS OR REVENUES OF ANY KIND; REGARDLESS OF THE FORM OF ACTION, WHETHER BASED ON CONTRACT; TORT; NEGLIGENCE OF SMSC OR OTHERS; STRICT LIABILITY; BREACH OF WARRANTY; OR OTHERWISE; WHETHER OR NOT ANY REMEDY OF BUYER IS HELD TO HAVE FAILED OF ITS ESSENTIAL PURPOSE, AND WHETHER OR NOT SMSC HAS BEEN ADVISED OF THE POSSIBILITY OF SUCH DAMAGES.

Contents

Chapter 1	LAN83C183 Functional Description	
1.1	OVERVIEW	11
1.1.1	Channel Operation	11
1.1.2	Data Paths	11
1.2	BLOCK DIAGRAM DESCRIPTION	16
1.2.1	Oscillator and Clock	16
1.2.2	Controller Interface	16
1.2.3	Encoder	20
1.2.4	Decoder	22
1.2.5	Scrambler	23
1.2.6	Descrambler	23
1.2.7	Twisted-Pair Transmitters	24
1.2.8	Twisted-Pair Receivers	27
1.2.9	FX Transmitter and Receiver	29
1.2.10	Clock and Data Recovery	31
1.2.11	Link Integrity and AutoNegotiation	31
1.2.12	Link Indication	34
1.2.13	Collision	35
1.2.14	LED Drivers	36
1.3	START OF PACKET	38
1.3.1	100 Mbits/s	38
1.3.2	10 Mbits/s	38
1.4	END OF PACKET	39
1.4.1	100 Mbits/s	39
1.4.2	10 Mbits/s	39
1.5	FULL/HALF DUPLEX MODE	41
1.5.1	Forcing Full/Half Duplex Operation	41
1.5.2	Full/Half Duplex Indication	41
1.5.3	Loopback	41
1.6	REPEATER MODE	42
1.7	10/100 MBITS/S SELECTION	42
1.7.1	Forcing 10/100 Mbits/s Operation	42
1.7.2	Autoselecting 10/100 Mbits/s Operation	42
1.7.3	10/100 Mbits/s Indication	42
1.8	JABBER	43

1.9	AUTOMATIC JAM	43
1.9.1	100 Mbits/s JAM	43
1.9.2	10 Mbits/s JAM	43
1.10	RESET	44
1.11	POWERDOWN	44
1.12	RECEIVE POLARITY CORRECTION	44

Chapter 2 Signal Descriptions

2.1	MEDIA INTERFACE SIGNALS	46
2.2	CONTROLLER INTERFACE SIGNALS (MII)	47
2.3	MANAGEMENT INTERFACE	48
2.4	MISCELLANEOUS SIGNALS	48
2.5	LEDS	50
2.6	POWER SUPPLY	51

Chapter 3 Registers

3.1	BIT TYPES	54
3.2	MI SERIAL PORT REGISTER SUMMARY	55
3.3	REGISTERS	57
3.3.1	Control Register (Register 0)	57
3.3.2	Status Register (Register 1)	58
3.3.3	PHY ID 1 Register (Register 2)	60
3.3.4	PHY ID 2 Register (Register 3)	61
3.3.5	AutoNegotiation Advertisement Register (Register 4)	61
3.3.6	AutoNegotiation Remote End Capability Register (Register 5)	63
3.3.7	Configuration 1 Register (Register 16)	64
3.3.8	Configuration 2 Register (Register 17)	66
3.3.9	Status Output Register (Register 18)	68
3.3.10	Interrupt Mask Register (Register 19)	69
3.3.11	Reserved Register (Register 20)	71

Chapter 4 Management Interface

4.1	SIGNAL DESCRIPTION	74
4.2	GENERAL OPERATION	75
4.3	MULTIPLE REGISTER ACCESS	75
4.4	FRAME STRUCTURE	77
4.5	REGISTER STRUCTURE	78
4.6	INTERRUPTS	79

Chapter 5 Specifications

5.1	ABSOLUTE MAXIMUM RATINGS	82
5.2	ELECTRICAL CHARACTERISTICS	83
5.2.1	Twisted-Pair DC Characteristics	84
5.2.2	FX Characteristics, Transmit	87
5.3	AC ELECTRICAL CHARACTERISTICS	89
5.3.1	25 MHz Input/Output Clock Timing Characteristics	90

5.3.2	Transmit Timing Characteristics	91
5.3.3	Receive Timing Characteristics	93
5.3.4	Collision and JAM Timing Characteristics	97
5.3.5	Link Pulse Timing Characteristics	100
5.3.6	Jabber Timing Characteristics	103
5.4	LED DRIVER TIMING CHARACTERISTICS	104
5.4.1	MI Serial Port Timing Characteristics	105
5.5	PINOUTS AND PACKAGE DRAWINGS	107
5.5.1	Pinouts	107
5.5.2	LAN83C183 Pin Layout	112
5.6	MECHANICAL DRAWING	113

Figures

1.1	LAN83C183 Device Block Diagram	12
1.2	100BASE-TX/FX and 10BASE-T Frame Format	13
1.3	MII Frame Format	14
1.4	TP Output Voltage Template	25
1.5	TP Input Voltage Template (10 Mbits/s)	28
1.6	Link Pulse Output Voltage Template (10 Mbits/s)	32
1.7	NLP vs FLP Link Pulse	33
1.8	SOI Output Voltage Template - 10 Mbits/s	40
2.1	Device Logic Diagram	45
4.1	MI Serial Port Frame Timing Diagram	75
4.2	MI Serial Frame Structure	77
4.3	MDIO Interrupt Pulse	79
5.1	25 MHz Output Timing	90
5.2	Transmit Timing - 100 Mbits/s	92
5.3	Transmit Timing - 10 Mbits/s	92
5.4	Receive Timing, Start of Packet - 100 Mbits/s	94
5.5	Receive Timing, End of Packet - 100 Mbits/s	95
5.6	Receive Timing, Start of Packet - 10 Mbits/s	95
5.7	Receive Timing, End of Packet - 10 Mbits/s	96
5.8	RX_EN Timing	96
5.9	Collision Timing, Receive 100 Mbits/s	97
5.10	Collision Timing, Receive 10 Mbits/s	98
5.11	Collision Timing, Transmit - 100 Mbits/s	98
5.12	Collision Timing, Transmit - 10 Mbits/s	98
5.13	Collision Test Timing	99
5.14	JAM Timing	99
5.15	NLP Link Pulse Timing	101
5.16	FLP Link Pulse Timing	102
5.17	Jabber Timing	103
5.18	LED Driver Timing	104
5.19	MI Serial Port Timing	105
5.20	MDIO Interrupt Pulse Timing	106
5.21	LAN83C183 64-Pin LQFP, Top View	112
5.22	64-Pin LQFP Mechanical Drawing	113

Tables

1.1	Transmit Preamble and SFD Bits at MAC Nibble Interface	14
1.2	Receive Preamble and SFD Bits at MAC Nibble Interface	15
1.3	4B/5B Symbol Mapping	18
1.4	4B/5B Symbol Mapping	21
1.5	TP Output Voltage - 10 Mbits/s	25
1.6	Transmit Level Adjust	26
1.7	FX Transmit Level Adjust	30
1.8	PLED_[1:0] Output Select Bit Encoding	36
1.9	LED Normal Function Definition	37
1.10	LED Event Definition	37
3.1	MI Register Bit Type Definition	54
4.1	MI Serial Port Register Summary	78
5.1	Absolute Maximum Ratings	82
5.2	DC Characteristics	83
5.3	Twisted Pair Characteristics (Transmit)	84
5.4	Twisted Pair Characteristics (Receive)	86
5.5	FX Characteristics, Transmit	87
5.6	FX Characteristics, Receive	88
5.7	Test Conditions	89
5.8	25 MHz Input/Output Clock	90
5.9	Transmit Timing	91
5.10	Receive Timing	93
5.11	Collision and Jam Timing	97
5.12	Link Pulse Timing	100
5.13	Jabber Timing	103
5.14	LED Driver Timing	104
5.15	MI Serial Port Timing	105
5.16	LAN83C183 Pin List (by Signal Category)	107
5.17	LAN83C183 Pin List (by Pin Number)	110

Chapter 1

LAN83C183 Functional Description

This chapter is a functional description of the PHY device with the following sections:

- Section 1.1, “Overview”
- Section 1.2, “Block Diagram Description”
- Section 1.3, “Start of Packet”
- Section 1.4, “End of Packet”
- Section 1.5, “Full/Half Duplex Mode”
- Section 1.6, “Repeater Mode”
- Section 1.7, “10/100 Mbits/s Selection”
- Section 1.8, “Jabber”
- Section 1.9, “Automatic Jam”
- Section 1.10, “Reset”
- Section 1.11, “Powerdown”
- Section 1.12, “Receive Polarity Correction”

1.1 OVERVIEW

This section gives a brief overview of the device functional operation. The LAN83C183 is a complete 10/100 Mbits/s Ethernet Media Interface IC. A block diagram is shown in Figure 1.1.

1.1.1 Channel Operation

The PHY operates in the 100BASE-TX or 100BASE-FX modes at 100 Mbits/s, or in the 10BASE-T mode at 10 Mbits/s. The 100 Mbits/s modes and the 10 Mbits/s mode differ in data rate, signaling protocol, and allowed wiring as follows:

- 100BASE-TX mode uses two pairs of category 5 or better UTP or STP twisted-pair cable with 4B5B encoded, scrambled, and MLT3 coded 62.5-MHz ternary data to achieve a throughput of 100 Mbits/s.
- The 100BASE-FX mode uses two fiber cables with 4B5B encoded, 125-MHz binary data to achieve a throughput of 100 Mbits/s.
- 10 Mbits/s mode uses two pairs of category 3 or better UTP or STP twisted-pair cable with Manchester encoded 10-MHz binary data to achieve a 10 Mbits/s throughput

The data symbol format on the twisted-pair cable for the 100 and 10 Mbits/s modes is defined in IEEE 802.3 specifications and shown in Figure 1.2.

1.1.2 Data Paths

In each device, there is a transmit data path and a receive data path associated with each PHY channel. The transmit data path is from the Controller Interface to the twisted-pair transmitter. The receive data path is from the twisted-pair receiver to the Controller Interface.

Figure 1.1 LAN83C183 Device Block Diagram

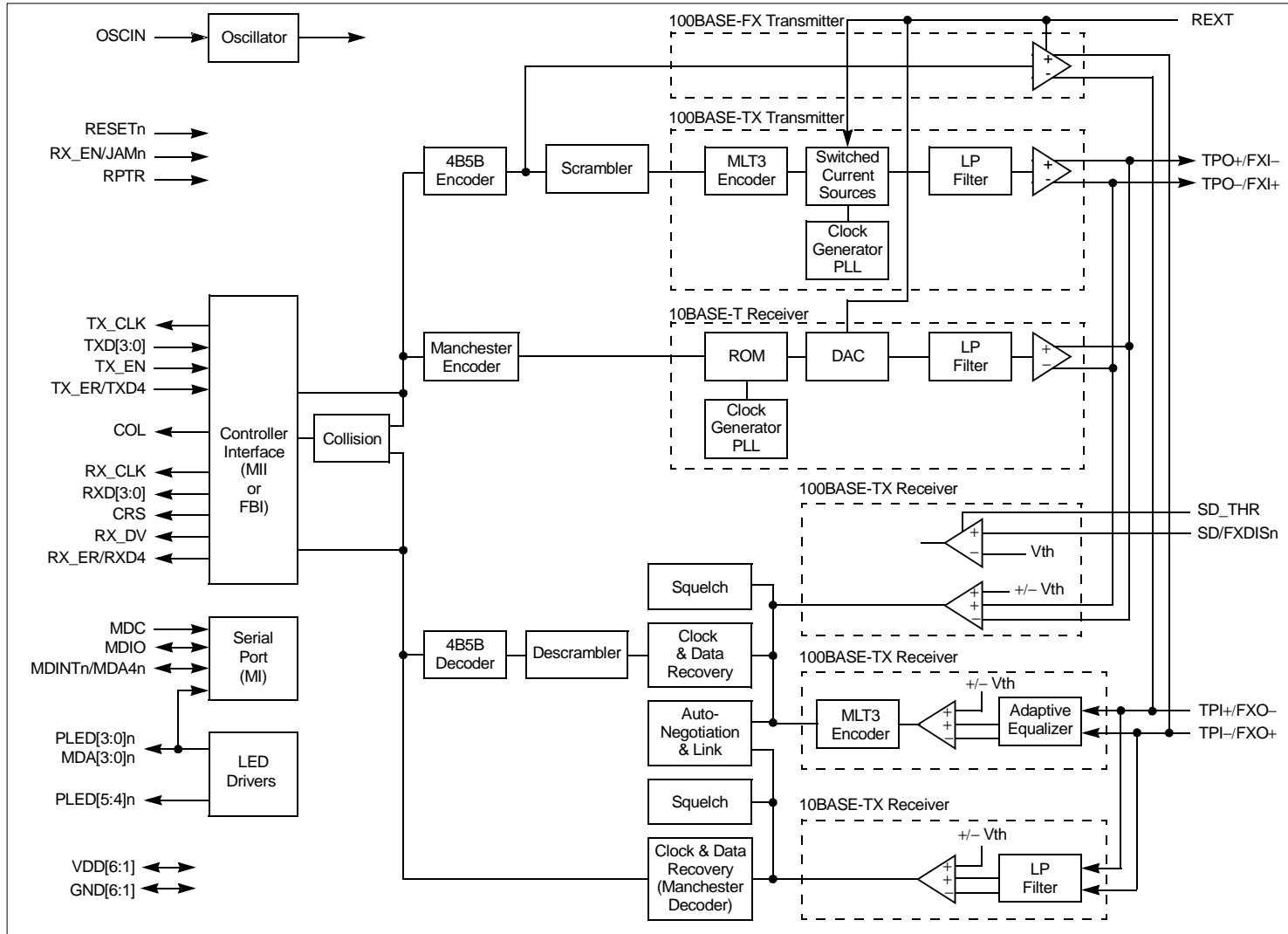
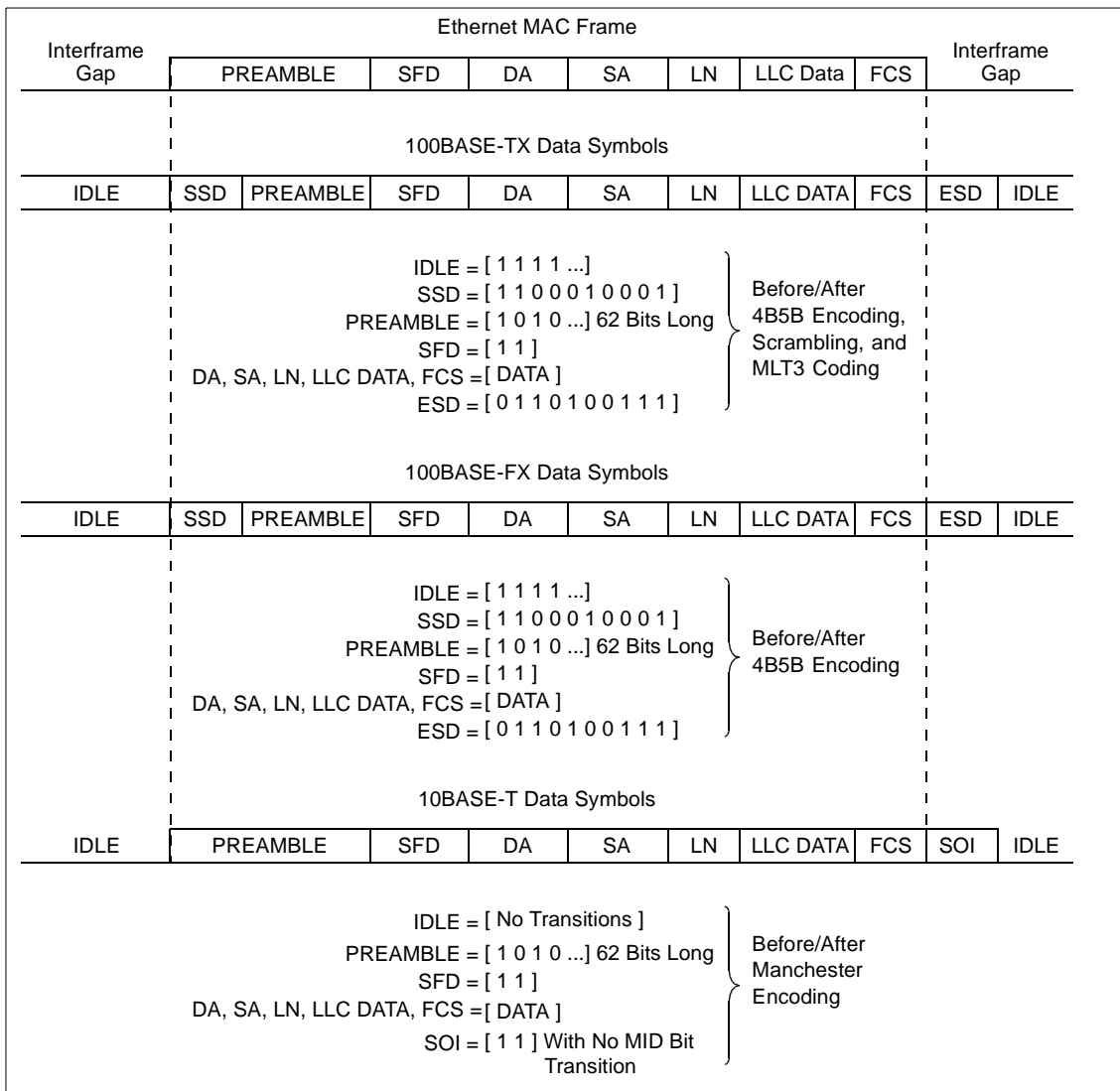

Figure 1.2 100BASE-TX/FX and 10BASE-T Frame Format



to an external Ethernet controller. The format of the received data at the Controller interface is as shown in Table 1.2.

Table 1.2 Receive Preamble and SFD Bits at MAC Nibble Interface

Signals	Bit Value																				
RXDO	X	1 ¹	1	1	1	1	1	1	1	1	1	1	1	1	1	1	1	1 ²	1	D0 ³	D4 ⁴
RXD1	X	0	0	0	0	0	0	0	0	0	0	0	0	0	0	0	0	0	0	D1	D5
RXD2	X	1	1	1	1	1	1	1	1	1	1	1	1	1	1	1	1	1	1	D2	D6
RXD3	X	0	0	0	0	0	0	0	0	0	0	0	0	0	0	0	0	0	0	D3	D7
RX_DV	0	1	1	1	1	1	1	1	1	1	1	1	1	1	1	1	1	1	1	1	1

1. First preamble nibble received. Depending on the mode, the device may eliminate either all or some of the preamble nibbles, up to the first SFD nibble.
2. First SFD nibble received.
3. First data nibble received.
4. D0 through D7 are the first 8 bits of the data field.

1.1.2.2 100BASE-FX

100BASE-FX operation is similar to 100BASE-TX operation except:

- The transmit output/receive input is not scrambled or MLT3 encoded
- The transmit data is output to a FX transmitter instead of the TP wavershaper/transmitter
- The receive data is input to the FX ECL level detector instead of the equalizer and associated TP circuitry
- The FX Interface has a signal detect input

1.1.2.3 10BASE-T

10BASE-T operation is similar to the 100BASE-TX operation except:

- There is no scrambler/descrambler
- The encoder/decoder is Manchester instead of 4B5B
- The data rate is 10 Mbits/s instead of 100 Mbits/s,
- The twisted-pair symbol data is two-level Manchester instead of ternary MLT-3.
- The transmitter generates link pulses during the idle period
- The transmitter detects the jabber condition
- The receiver detects link pulses and implements the AutoNegotiation algorithm

1.2 BLOCK DIAGRAM DESCRIPTION

The LAN83C183 PHY device has the following main blocks:

- Oscillator and Clock
- Controller Interface
- 4B5B/Manchester Encoder/Decoder
- Scrambler/Descrambler
- Twisted-Pair Transmitters
- Fiber Transmitter
- Twisted-Pair Receivers
- Fiber Receiver
- Clock and Data Recovery
- AutoNegotiation/Link Integrity
- Descrambler
- Collision Detection
- LED Drivers

A Management Interface (MI) serial port provides access to 11 internal PHY registers.

Figure 1.1 shows the main blocks, along with their associated signals. The following sections describe each of the blocks in Figure 1.1. The performance of the device in both the 10 and 100 Mbits/s modes is described.

1.2.1 Oscillator and Clock

The LAN83C183 requires a 25 MHz reference frequency for internal signal generation. This 25 MHz reference frequency is generated with either an external 25 MHz crystal connected between OSCIN and GND or with the application of an external 25-MHz clock to OSCIN.

The device provides either a 2.5-MHz or 25-MHz reference clock at the TX_CLK or RX_CLK output pins for 10-MHz or 100-MHz operation, respectively.

1.2.2 Controller Interface

This section describes the controller interface operation. The LAN83C183 has two interfaces to an external controller:

- Media Independent Interface (MII)
- Five Bit Interface (FBI)

1.2.2.1 MII INTERFACE

The device has an MII interface to an external Ethernet Media Access Controller (MAC).

MII (100 Mbits/s) – The MII is a nibble wide packet data interface defined in IEEE 802.3 and shown in Figure 1.3. The LAN83C183 meets all the MII requirements outlined in IEEE 802.3. The LAN83C183 can directly connect, without any external logic, to any Ethernet controller or other device that also complies with the IEEE 802.3 MII specifications.

The MII interface contains the following signals:

- Transmit data bits (TXD[3:0])
- Transmit clock (TX_CLK)
- Transmit enable (TX_EN)
- Transmit error (TX_ER)
- Receive data bits (RXD[3:0])
- Receive clock (RX_CLK)
- Carrier sense (CRS)
- Receive data valid (RX_DV)
- Receive data error (RX_ER)
- Collision (COL)

The transmit and receive clocks operate at 25 MHz in 100 Mbits/s mode.

On the transmit side, the TX_CLK output runs continuously at 25 MHz. When no data is to be transmitted, TX_EN must be deasserted. While TX_EN is deasserted, TX_ER and TXD[3:0] are ignored and no data is clocked into the device. When TX_EN is asserted on the rising edge of TX_CLK, data on TXD[3:0] is clocked into the device on the rising edge of the TX_CLK output clock. TXD[3:0] input data is nibble wide packet data whose format must be the same as specified in IEEE 802.3 and shown in Figure 1.3. When all data on TXD[3:0] has been latched into the device, TX_EN must be deasserted on the rising edge of TX_CLK.

TX_ER is also clocked in on the rising edge of TX_CLK. TX_ER is a transmit error signal. When this signal is asserted, the device substitutes an error nibble in place of the normal data nibble that was clocked in on TXD[3:0]. The error nibble is defined to be the /H/ symbol, which is defined in IEEE 802.3 and shown in Table 1.3.

Table 1.3 4B/5B Symbol Mapping

Symbol Name	Description	5B Code	4B Code
0	Data 0	0b11110	0b0000
1	Data 1	0b01001	0b0001
2	Data 2	0b10100	0b0010
3	Data 3	0b10101	0b0011
4	Data 4	0b01010	0b0100
5	Data 5	0b01011	0b0101
6	Data 6	0b01110	0b0110
7	Data 7	0b01111	0b0111
8	Data 8	0b10010	0b1000
9	Data 9	0b10011	0b1001
A	Data A	0b10110	0b1010
B	Data B	0b10111	0b1011
C	Data C	0b11010	0b1100
D	Data D	0b11011	0b1101
E	Data E	0b11100	0b1110
F	Data F	0b11101	0b1111
I	Idle	0b11111	0b0000
J	SSD #1	0b11000	0b0101
K	SSD #2	0b10001	0b0101
T	ESD #1	0b01101	0b0000
R	ESD #2	0b00111	0b0000
H	Halt	0b00100	Undefined
–	Invalid codes	All others ¹	0b0000*

1. These 5B codes are not used. The decoder decodes these 5B codes to 4B 0000. The encoder encodes 4B 0000 to 5B 11110, as shown in symbol Data 0.

Because the OSCIN input clock generates the TX_CLK output clock, the TXD[3:0], TX_EN, and TX_ER signals are also clocked in on rising edges of OSCIN.

On the receive side, as long as a valid data packet is not detected, CRS and RX_DV are deasserted and the RXD[3:0] signals are held LOW. When the start of packet is detected, CRS and RX_DV are asserted on the falling edge of RX_CLK. The assertion of RX_DV indicates that valid data is clocked out on RXD[3:0] on the falling edge of the RX_CLK. The RXD[3:0] data has the same frame structure as the TXD[3:0] data and is specified in IEEE 802.3 and shown in Figure 1.3. When the end

of the packet is detected, CRS and RX_DV are deasserted, and RXD[3:0] is held LOW. CRS and RX_DV also stay deasserted if the device is in the Link Fail State.

RX_ER is a receive error output that is asserted when certain errors are detected on a data nibble. RX_ER is asserted on the falling edge of RX_CLK for the duration of that RX_CLK clock cycle during which the nibble containing the error is output on RXD[3:0].

The collision output, COL, is asserted whenever the collision condition is detected.

MII (10 Mbits/s) – MII 10 Mbits/s operation is identical to 100 Mbits/s operation except:

- The TX_CLK and RX_CLK clock frequency is reduced to 2.5 MHz
- TX_ER is ignored
- RX_ER is disabled and always held LOW
- Receive operation is modified as follows:

On the receive side, when the squelch circuit determines that invalid data is present on the TP inputs, the receiver is idle. During idle, RX_CLK follows TX_CLK, RXD[3:0] is held LOW, and CRS and RX_DV are deasserted. When a start of packet is detected on the TP receive inputs, CRS is asserted and the clock recovery process starts on the incoming TP input data. After the receive clock has been recovered from the data, the RX_CLK is switched over to the recovered clock and the data valid signal RX_DV is asserted on a falling edge of RX_CLK. Once RX_DV is asserted, valid data is clocked out on RXD[3:0] on the falling edge of RX_CLK. The RXD[3:0] data has the same packet structure as the TXD[3:0] data and is formatted on RXD[3:0] as specified in IEEE 802.3 and shown in Figure 1.3. When the end of packet is detected, CRS and RX_DV are deasserted. CRS and RX_DV also stay deasserted as long as the device is in the Link Fail State.

1.2.2.2 FBI INTERFACE

The Five Bit Interface (also referred to as FBI) is a five-bit wide interface that is produced when the 4B5B encoder/decoder is bypassed. The FBI is primarily used for repeaters or Ethernet controllers that have integrated encoder/decoders.

The FBI is identical to the MII except:

- The FBI data path is five bits wide, not nibble wide like the MII
- The TX_ER pin is reconfigured to be the fifth transmit data bit (TXD4)
- The RX_ER pin is reconfigured to be the fifth receive data bit (RXD4)
- CRS is asserted as long as the device is in the Link Pass State
- COL is not valid
- RX_DV is not valid
- The TX_EN pin is ignored

There is no FBI operation in the 10 Mbits/s mode.

1.2.2.3 SELECTION OF MII OR FBI

FBI Selection – The FBI is automatically enabled when the 4B5B encoder/decoder is bypassed. Bypassing the encoder/decoder passes the 5B symbols between the receiver/transmitter directly to the FBI without any alterations or substitutions. To

bypass the 4B5B encoder/decoder, set the Bypass Encoder bit (BYP_ENC) in the MI serial port Configuration 1 register.

When the FBI is enabled, it may also be desirable to bypass the scrambler/descrambler and disable the internal CRS loopback function. To bypass the scrambler/descrambler, set the Bypass Scrambler bit (BYP_SCR) in the MI serial port Configuration 1 register. To disable the internal CRS loopback, set the TX_EN to CRS loopback disable bit (TXEN_CRS) in the MI serial port Configuration 1 register.

MII Selection – To disable the MII (and FBI) inputs and outputs, set the MII_DIS bit in the MI serial port Control register. When the MII is disabled, the MII and FBI inputs are ignored, and the MII, FBI, and TPI outputs are placed in a high-impedance state. The MII pins affected are:

- RX_CLK
- RXD[3:0]
- RX_DV
- RX_ER
- COL

If the MI address lines, MDA[4:0]n, are pulled HIGH during reset or powerup, the LAN83C183 powers up and resets with the MII and FBI disabled. Otherwise, the LAN83C183 powers up and resets with the MII and FBI enabled.

In addition, when the R/J_CFG bit in the MI serial port Configuration 1 register is LOW, the RX_EN/JAMn pin is configured for RX_EN operation. If the RX_EN pin is LOW in this situation, the MII controller interface outputs are placed in the high-impedance state.

1.2.3 Encoder

This section describes the 4B5B encoder, which is used in 100 Mb/s operation. It also describes the Manchester Encoder, used in 10BASE-T operation.

1.2.3.1 4B5B ENCODER (100 MBITS/S)

100BASE-TX operation requires that the data be 4B5B encoded. The 4B5B Encoder block shown in Figure 1.1 converts the four-bit data nibbles into five-bit data words. The mapping of the 4B nibbles to 5B codewords is specified in IEEE 802.3 and is shown in Table 1.4.

Table 1.4 4B/5B Symbol Mapping

Symbol Name	Description	5B Code	4B Code
0	Data 0	11110	0000
1	Data 1	01001	0001
2	Data 2	10100	0010
3	Data 3	10101	0011
4	Data 4	01010	0100
5	Data 5	01011	0101
6	Data 6	01110	0110
7	Data 7	01111	0111
8	Data 8	10010	1000
9	Data 9	10011	1001
A	Data A	10110	1010
B	Data B	10111	1011
C	Data C	11010	1100
D	Data D	11011	1101
E	Data E	11100	1110
F	Data F	11101	1111
I	Idle	11111	0000
J	SSD #1	11000	0101
K	SSD #2	10001	0101
T	ESD #1	01101	0000
R	ESD #2	00111	0000
H	Halt	00100	Undefined
---	Invalid codes	All others ¹	0000

1. These 5B codes are not used. The decoder converts them to a 4B code of 0000. The encoder converts the 4B 0000 code to the 5B 11110 code, as shown in symbol 0.

The 4B5B encoder takes 4B (four-bit) nibbles from the Transmit MAC block, converts them into 5B (five-bit) words according to Table 1.4, and sends the 5B words to the scrambler. The 4B5B encoder also substitutes the first eight bits of the preamble with the Start of Stream Delimiter (SSD) (/J/K/ symbols) and adds an End of Stream Delimiter (ESD) (/T/R/ symbols) to the end of each packet, as defined in IEEE 802.3 and shown in Figure 1.2. The 4B5B encoder also fills the period between packets (idle period), with a continuous stream of idle symbols, as shown in Figure 1.2.

1.2.3.2 MANCHESTER ENCODER (10 MBITS/S)

The Manchester Encoder shown in Figure 1.1 is used for 10 Mbits/s operation. It combines clock and non-return to zero inverted (NRZI) data such that the first half of

the data bit contains the complement of the data, and the second half of the data bit contains the true data, as specified in IEEE 802.3. This process guarantees that a transition always occurs in the middle of the bit cell. The Manchester encoder on the device converts the 10 Mbps NRZI data from the Ethernet controller interface into a single data stream for the TP transmitter and adds a start of idle pulse (SOI) at the end of the packet as specified in IEEE 802.3 and shown in Figure 1.2. The Manchester encoding process is only done on actual packet data; during the idle period between packets, no signal is transmitted except for periodic link pulses.

1.2.3.3 ENCODER BYPASS

Setting the Bypass Encoder/Decoder bit (BYP_ENC) in the MI serial port Configuration 1 register bypasses the 4B5B encoder. When this bit is set, 5B code words are passed directly from the controller interface to the scrambler without any of the alterations described in Section 1.2.3.1, “4B5B Encoder (100 Mbps/s),” page 1-20. Setting the bit automatically places the device in the FBI mode as described in the subsection entitled “FBI Selection” on page 1-19.

1.2.4 Decoder

This section describes the 4B5B decoder, used in 100 Mbps operation, which converts 5B encoded data to 4B nibbles. It also describes the Manchester Decoder, used in 10BASE-T operation.

1.2.4.1 4B5B DECODER (100 MBITS/S)

Because the TP input data is 4B5B encoded on the transmit side, the 4B5B decoder must decode it on the receive side. The mapping of the 5B codewords to the 4B nibbles is specified in IEEE 802.3. The 4B5B decoder takes the 5B codewords from the descrambler, converts them into 4B nibbles according to Table 1.4, and sends the 4B nibbles to the receive Ethernet controller.

The 4B5B decoder also strips off the SSD delimiter (/J/K/ symbols), and replaces it with two 4B Data 5 nibbles (/5/ symbol). It also strips off the ESD delimiter (/T/R/ symbols), and replaces it with two 4B Data 0 nibbles (/I/ symbol), per IEEE 802.3 specifications (see Figure 1.2).

The 4B5B decoder detects SSD, ESD, and codeword errors in the incoming data stream as specified in IEEE 802.3. To indicate these errors, the device asserts the RX_ER output as well as the SSD, ESD, and CWRD bits in the MI serial port Status Output register while the errors are being transmitted across RXD[3:0].

1.2.4.2 MANCHESTER DECODER (10 MBITS/S)

In Manchester coded data, the first half of the data bit contains the complement of the data, and the second half of the data bit contains the true data. The Manchester Decoder converts the single data stream from the TP receiver into non-return to zero (NRZ) data for the controller interface. To do this, it decodes the data and strips off the SOI pulse. Because the Clock and Data Recovery block has already separated the clock and data from the TP receiver, that block inherently performs the Manchester decoding.

1.2.4.3 DECODER BYPASS

Setting the Bypass Encoder/Decoder bit (BYP_ENC) in the MI serial port Configuration 1 register bypasses the 4B5B decoder. When this bit is set, 5B code words are passed directly to the controller interface from the descrambler without any of the alterations described in Section 1.2.4, “Decoder,” page 1-22. Additionally, the

CRS pin is continuously asserted whenever the device is in the Link Pass state. Setting the bit automatically places the device in the FBI mode as described in the subsection entitled “FBI Selection” on page 1-19.

1.2.5 Scrambler

100BASE-TX transmission requires scrambling to reduce the radiated emissions on the twisted pair. The scrambler takes the NRZI encoded data from the 4B5B encoder, scrambles it per the IEEE 802.3 specifications, and sends it to the TP transmitter. A scrambler is not used for 10 Mbits/s operation.

1.2.5.1 SCRAMBLER BYPASS

Setting the Bypass Encoder/Decoder bit (BYP_SCR) in the MI serial port Configuration 1 register bypasses the scrambler. When this bit is set, 5B data bypasses the scrambler and goes directly to the 100BASE-TX transmitter.

1.2.6 Descrambler

The descrambler block shown in Figure 1.1 is used in 100BASE-TX operation. The device descrambler takes the scrambled NRZI data from the data recovery block, descrambles it according to IEEE 802.3 specifications, aligns the data on the correct 5B word boundaries, and sends it to the 4B5B decoder.

The algorithm for synchronization of the descrambler is the same as the algorithm outlined in the IEEE 802.3 specification.

After the descrambler is synchronized, it maintains synchronization as long as enough descrambled idle pattern ones are detected within a given interval. To stay in synchronization, the descrambler needs to detect at least 25 consecutive descrambled idle pattern ones in a 1 ms interval. If 25 consecutive descrambled idle pattern ones are not detected within the 1 ms interval, the descrambler goes out of synchronization and restarts the synchronization process.

If the descrambler is in the unsynchronized state, the descrambler Loss of Synchronization Detect bit (LOSS_SYNC) is set in the MI serial port Status Output register. The bit stays set until the descrambler achieves synchronization.

The descrambler is disabled for 10BASE-T operation.

1.2.6.1 DESCRAMBLER BYPASS

Setting the Bypass Encoder/Decoder bit (BYP_SCR) in the MI serial port Configuration 1 register bypasses the descrambler. When this bit is set, 5B data bypasses the descrambler and goes directly from the 100BASE-T receiver to the 4B5B decoder.

1.2.7 Twisted-Pair Transmitters

This section describes the operation of the 10 and 100 Mbits/s TP transmitters.

1.2.7.1 100 MBITS/S TP TRANSMITTER

The TP transmitter consists of an MLT3 encoder, waveform generator, and line driver.

The MLT3 encoder converts the NRZI data from the scrambler into a three-level code required by IEEE 802.3. MLT3 coding uses three levels, converting ones to transitions between the three levels, and zeros to no transitions or changes in level.

The purpose of the waveform generator is to shape the transmit output pulse. The waveform generator takes the MLT3 three level encoded waveform and uses an array of switched current sources to control the shape of the twisted-pair output signal. The waveform generator consists of switched current sources, a clock generator, filter, and logic. The switched current sources control the rise and fall time as well as signal level to meet IEEE 802.3 requirements. The output of the switched current sources goes through a second order low-pass filter that “smooths” the current output and removes any high-frequency components. In this way, the waveform generator preshapes the output waveform transmitted onto the twisted-pair cable such that the waveform meets the pulse template requirements outlined in IEEE 802.3. The waveform generator eliminates the need for any external filters on the TP transmit output.

The line driver converts the shaped and smoothed waveform to a current output that can drive greater than 100 meters of category 5 unshielded twisted-pair cable or 150-ohm shielded twisted-pair cable.

1.2.7.2 10 MBITS/S TP TRANSMITTER

Even though the 10 Mbits/s transmitter operation is much different than that of 100 Mbits/s, it also consists of a waveform generator and line driver (see Figure 1.1).

The waveform generator, which consists of a ROM, DAC, clock generator, and filter, shapes the output transmit pulse. The DAC generates a stair-stepped representation of the desired output waveform. The stairstepped DAC output then is passed through a low-pass filter to “smooth” the DAC output and remove any high-frequency components. The DAC values are determined from the data at the ROM addresses. The data is chosen to shape the pulse to the desired template. The clock generator clocks the data into the DAC at high speed. In this way, the waveform generator preshapes the output waveform to be transmitted onto the twisted-pair cable to meet the pulse template requirements outlined in IEEE 802.3 Clause 14 and shown in Figure 1.4 and Table 1.5. The waveshaper replaces and eliminates external filters on the TP transmit output.

The line driver converts the shaped and smoothed waveform to a current output that can drive greater than 100 meters of category 3/4/5 100-ohm unshielded twisted-pair cable or 150-ohm shielded twisted-pair cable without any external filters.

During the idle period, no output signals are transmitted on the TP outputs except for link pulses.

Figure 1.4 TP Output Voltage Template

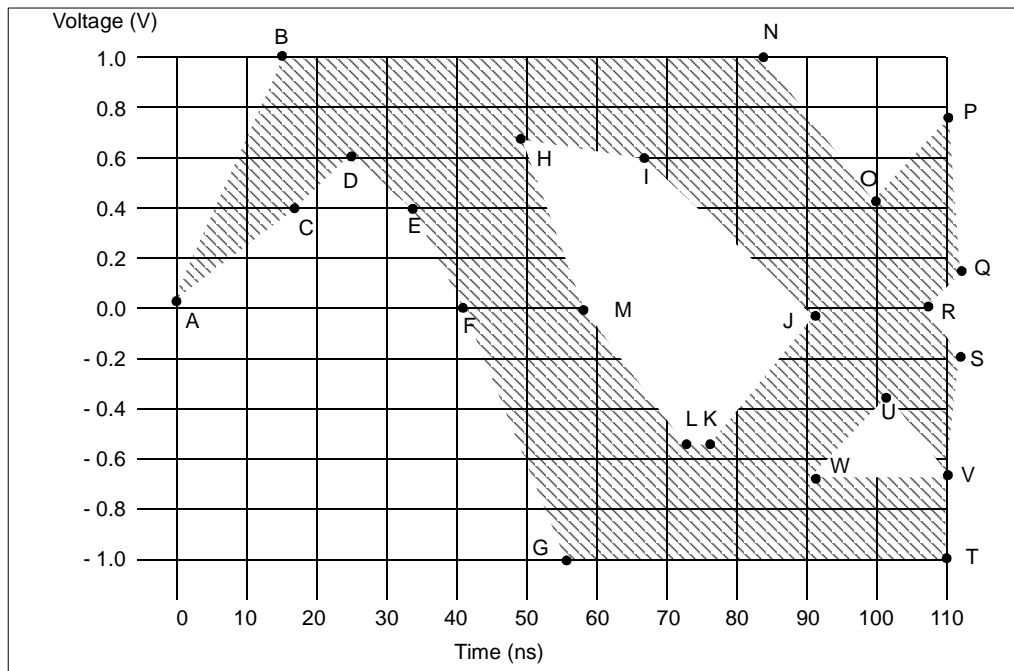

Table 1.5 TP Output Voltage - 10 Mbits/s

Reference	Time (ns) Internal MAU	Voltage (V)
A	0	0
B	15	1.0
C	15	0.4
D	25	0.55
E	32	0.45
F	39	0
G	57	-1.0
H	48	0.7
I	67	0.6
J	89	0
K	74	-0.55
L	73	-0.55
M	61	0
N	85	1.0
O	100	0.4
P	110	0.75
Q	111	0.15
R	111	0

Table 1.5 TP Output Voltage - 10 Mbits/s (Cont.)

Reference	Time (ns) Internal MAU	Voltage (V)
S	111	-0.15
T	110	-1.0
U	100	-0.3
V	110	-0.7
W	90	-0.7

1.2.7.3 TRANSMIT LEVEL ADJUST

The transmit output current level is derived from an internal reference voltage and the external resistor on the REXT pin. The transmit level can be adjusted with either:

- The external resistor on the REXT pin, or
- The four Transmit Level Adjust bits (TLVL[3:0]) in the MI serial port Configuration 1 register as shown in Table 1.6. The adjustment range is approximately -14% to +16% in 2% steps.

Table 1.6 Transmit Level Adjust

TLVL[3:0] Bits	Gain
0000	1.16
0001	1.14
0010	1.12
0011	1.10
0100	1.08
0101	1.06
0110	1.04
0111	1.02
1000	1.00
1001	0.98
1010	0.96
1011	0.94
1100	0.92
1101	0.90
1110	0.88
1111	0.86

1.2.7.4 TRANSMIT RISE AND FALL TIME ADJUST

The transmit output rise and fall time can be adjusted with the two Transmit Rise/Fall time adjust bits (TRF[1:0]) in the MI serial port Configuration 1 register. The adjustment range is -0.25 ns to $+0.5$ ns in 0.25 ns steps.

1.2.7.5 STP (150 OHM) CABLE MODE

The transmitter can be configured to drive 150 Ω shielded twisted-pair cable. To enable this configuration, set the Cable Type Select bit (CABLE) in the MI serial port Configuration 1 register. When STP mode is enabled, the output current is automatically adjusted to comply with IEEE 802.3 levels.

1.2.7.6 TRANSMIT ACTIVITY INDICATION

Appropriately setting the programmable LED Output Select bits in the MI serial port LED Configuration 2 register programs transmit activity to appear on some of the PLED[5:0] n pins. When one or more of the PLED[5:0] n pins is programmed to be an activity or transmit activity detect output, that pin is asserted LOW for 100 ms every time a transmit packet occurs. The PLED[5:0] n outputs are open-drain with resistor pullup and can drive an LED from V_{DD} or can drive other digital inputs. See Section 1.2.14, "LED Drivers," page 1-36 for more detailed information on the LED outputs.

1.2.7.7 TRANSMIT DISABLE

Setting the Transmit Disable bit (XMT_DIS) in the MI serial port Configuration 1 register disables the TP transmitter. When the bit is set, the TP transmitter is forced into the idle state, no data is transmitted, no link pulses are transmitted, and internal loopback is disabled.

1.2.7.8 TRANSMIT POWERDOWN

Setting the Transmit Powerdown bit (XMT_PDN) in the MI serial port Configuration 1 register powers down the TP transmitter. When the bit is set, the TP transmitter is powered down, the TP transmit outputs are high impedance, and the rest of the LAN83C183 operates normally.

1.2.8 Twisted-Pair Receivers

The device is capable of operating at either 10- or 100-Mbits/s. This section describes the twisted-pair receivers and squelch operation for both modes of operation.

1.2.8.1 100 MBITS/S TP RECEIVER

The TP receiver detects input signals from the twisted-pair input and converts them to a digital data bit stream ready for clock and data recovery. The receiver can reliably detect 100BASE-TX compliant transmitter data that has been passed through 0 to 100 meters of 100 Ω category 5 UTP or 150-ohm STP cable.

The 100 Mbits/s receiver consists of an adaptive equalizer, baseline wander correction circuit, comparators, and an MLT3 decoder. The TP inputs first go to an adaptive equalizer. The adaptive equalizer compensates for the low-pass characteristics of the cable, and can adapt and compensate for 0 to 100 meters of category 5, 100-ohm or 150-ohm STP cable. The baseline wander correction circuit restores the DC component of the input waveform that the external transformers have removed. The comparators convert the equalized signal back to digital levels and qualify the data with the squelch circuit. The MLT3 decoder takes the three-level

MLT3 encoded output data from the comparators and converts it to normal digital data to be used for clock and data recovery.

1.2.8.2 10 MBITS/S TP RECEIVER

The 10 Mb/s receiver detects input signals from the twisted-pair cable that are within the template shown in Figure 1.5. The TP inputs are biased by internal resistors and go through a low-pass filter designed to eliminate any high-frequency input noise. The output of the receive filter goes to two different types of comparators: squelch and zero crossing. The squelch comparator determines whether the signal is valid, and the zero crossing comparator senses the actual data transitions after the signal is determined to be valid. The output of the squelch comparator goes to the squelch circuit and is also used for link pulse detection, SOI detection, and reverse polarity detection. The output of the zero-crossing comparator is used for clock and data recovery in the Manchester decoder.

Figure 1.5 TP Input Voltage Template (10 Mb/s)

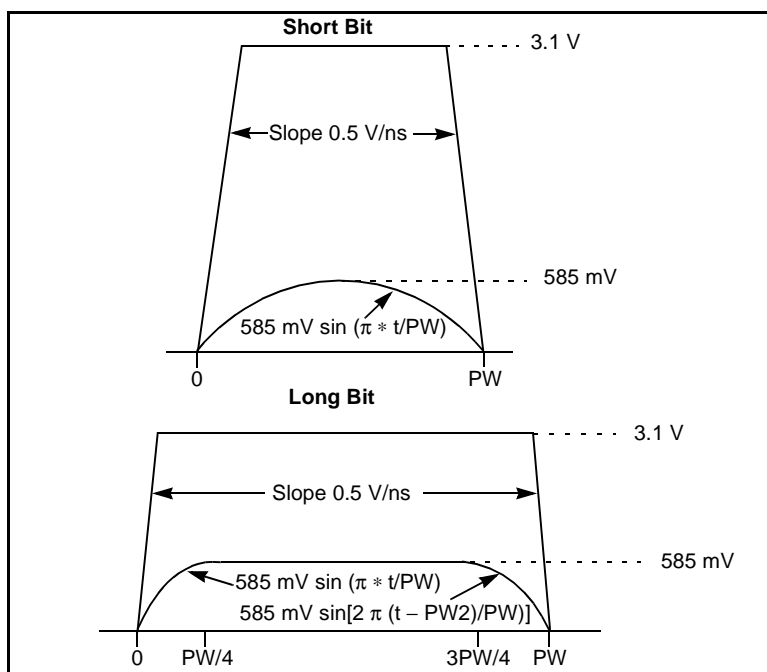

1.2.8.3 SQUELCH (100 MBITS/S)

The Squelch block determines if the TP input contains valid data. The 100 Mb/s TP squelch is one of the criteria used to determine link integrity. The squelch comparators compare the TP inputs against fixed positive and negative thresholds, called squelch levels. The output from the squelch comparator goes to a digital squelch circuit, which determines whether the receive input data on that port is valid. If the data is invalid, the receiver is in the squelched state. If the input voltage exceeds the squelch levels at least four times with alternating polarity within a 10 μ s interval, the squelch circuit determines that the data is valid and the receiver enters into the unsquelch state.

In the unsquelch state, the receive threshold level is reduced by approximately 30% for noise immunity reasons and is called the unsquelch level. When the receiver is in the unsquelch state, the input signal is considered valid.

The device stays in the unsquelch state until loss of data is detected. Loss of data is detected if no alternating polarity unsquelch transitions are detected during any 10 μ s interval. When a loss of data is detected, the receive squelch is turned on again.

1.2.8.4 SQUELCH (10 MBITS/S)

The TP squelch algorithm for 10 Mbits/s mode is identical to the 100 Mbits/s mode, except:

- The 10 Mbits/s TP squelch algorithm is not used for link integrity, but to sense the beginning of a packet
- The receiver goes into the unsquelch state if the input voltage exceeds the squelch levels for three bit times with alternating polarity within a 50 to 250 ns interval
- The receiver goes into the squelch state when SOI is detected
- Unsquelch detection has no effect on link integrity (link pulses are used in 10 Mbits/s mode for that purpose)
- Start of packet is determined when the receiver goes into the unsquelch state and CRS is asserted
- The receiver meets the squelch requirements defined in IEEE 802.3 Clause 14.

1.2.8.5 EQUALIZER DISABLE

Setting the Equalizer Disable bit (EQLZR) in the MI serial port Configuration 1 register disables the adaptive equalizer. When disabled, the equalizer is forced into the response it would normally have if zero cable length was detected.

1.2.8.6 RECEIVE LEVEL ADJUST

Setting the Receive Level Adjust bit (RLV0) in the MI serial port Configuration 1 register lowers the receiver squelch and unsquelch levels by 4.5 dB. Setting this bit may allow the device to support longer cable lengths.

1.2.8.7 RECEIVE ACTIVITY INDICATION

Appropriately setting the programmable LED output select bits in the MI serial port LED Configuration 2 register programs receive activity to appear on some of the PLED[5:0]_n pins. When one or more of the PLED[5:0]_n pins is programmed to be a receive activity or activity detect output, that pin is asserted LOW for 100 ms every time a receive packet occurs. The PLED[5:0]_n outputs are open-drain with resistor pullup and can drive an LED from V_{DD} or can drive another digital input. See Section 1.2.14, "LED Drivers," page 1-36 for more detailed information on the LED outputs.

1.2.9 FX Transmitter and Receiver

The FX transmitter and receiver implement the 100BASE-FX function defined in IEEE 802.3. 100BASE-FX is intended for transmission and reception of data over fiber and is specified to operate at 100 Mbits/s. Thus, the FX transmitter and receiver in the device only operate when the device is placed in 100 Mbits/s mode.

1.2.9.1 TRANSMITTER

The FX transmitter converts data from the 4B5B encoder into binary NRZI data and outputs the data onto the FXO+/- pins. The output driver is a differential current source that is able to drive a 100 Ω load to ECL levels. The FXO+/- pins can directly drive an external fiber optic transceiver. The FX transmitter meets all the requirements defined in IEEE 802.3.

The FX transmit output current level is derived from an internal reference voltage and the external resistor on the REXT pin. The FX transmit level can be adjusted with this resistor or it can also be adjusted with the two FX Transmit Level Adjust bits (FXLVL[1:0]) in the MI serial port Mask register as shown in Table 1.7.

Table 1.7 FX Transmit Level Adjust

FXLVL[1:0] Bits	Gain
11	1.30
10	1.15
01	0.85
00	1.00

1.2.9.2 RECEIVER

The FX receiver:

- Converts the differential ECL inputs on the FXI+/- pins to a digital bit stream
- Validates the data on FXI+/- with the SD/FXDISn input pin
- Enable or disables the FX interface with the SD/FXDISn pin.

The FX receiver meets all requirements defined in IEEE 802.3.

The input to the FXI+/- pins can be directly driven from a fiber optic transceiver and first goes to a comparator. The comparator compares the input waveform against the internal ECL threshold levels to produce a low jitter serial bit stream with internal logic levels. The data from the comparator output is then passed to the clock and data recovery block, provided that the signal detect input, SD/FXDISn, is asserted.

Signal Detect – The FX receiver has a signal detect input pin, SD/FXDISn, which indicates whether the incoming data on FXI+/- is valid or not. The SD/FXDISn input can be driven directly from an external fiber optic transceiver and meets all requirements defined in the IEEE 802.3 specifications.

The SD/FXDISn input goes directly to a comparator. The comparator compares the input waveform against the internal ECL threshold level to produce a digital signal with internal logic levels. The output of the signal detect comparator then goes to the link integrity and squelch blocks. If the SD/FXDISn input is asserted, the device is placed in the Link Pass state and the input data on FXI+/- is determined to be valid. If the SD/FXDISn input is deasserted, the device is placed in the Link Fail state and the input data on FXI+/- is determined to be invalid.

The SD_THR pin adjusts the ECL trip point of the SD/FXDISn input. When the SD_THR pin is tied to a voltage between GND and GND + 0.45V, the trip point of the SD/FXDISn ECL input buffer is internally set to VDD – 1.3 V. When the SD_THR pin is set to a voltage greater than GND + 0.85 V, the trip point of the SD/FXDISn ECL input buffer is set to the voltage that is applied to the SD_THR pin. The trip level for the SD/FXDISn input buffer must be set to VDD – 1.3 V. Having external control of the SD/FXDISn buffer trip level with the SD_THR pin allows this trip level to be referenced to an external supply, which facilitates connection to an external fiber optic transceiver. If the device is to be connected to a 3.3V external fiber optic transceiver, SD_THR must be tied to GND.

If the device is to be connected to a 5V external fiber optic transceiver, SD_THR must be tied to VDD – 1.3V, which can be accomplished with an external resistor divider. Refer to the ?Application Note? for more details on connections to external fiber optic transceivers.

1.2.9.3 FX DISABLE

The FX interface is disabled if the SD/FXDISn pin is connected to GND; otherwise, the FX interface is enabled. Disabling the FX interface automatically enables the TP interface. Conversely, enabling the TP interface disables the FX interface.

1.2.10 Clock and Data Recovery

This section describes clock and data recovery methods implemented in the device for both the 100 Mbits/s and 10 Mbits/s modes.

1.2.10.1 100 MBITS/S CLOCK AND DATA RECOVERY

Clock recovery is accomplished with a phase-locked-loop (PLL). If valid data is not present on the receive inputs, the PLL is locked to the 25-MHz TX_CLK signal. When the squelch circuit detects valid data on the receive TP input, and if the device is in the Link Pass state, the PLL input is switched to the incoming data on the receive inputs. The PLL then locks on to the transitions in the incoming signal to recover the clock. The recovered data clock is then used to generate the 25 MHz nibble clock, RX_CLK, which clocks data into the controller interface section.

The recovered clock extracted by the PLL latches in data from the TP receiver to perform data recovery. The data is then converted from a single bit stream into nibble wide data words according to the format shown in Figure 1.3

1.2.10.2 10 MBITS/S CLOCK AND DATA RECOVERY

The clock recovery process for 10 Mbits/s mode is identical to the 100 Mbits/s mode except:

- The recovered clock frequency is a 2.5 MHz nibble clock
- The PLL is switched from TX_CLK to the TP input when the squelch indicates valid data
- The PLL takes up to 12 transitions (bit times) to lock onto the preamble, so some of the preamble data symbols are lost. However, the clock recovery block recovers enough preamble symbols to pass at least six nibbles of preamble to the receive controller interface as shown in Figure 1.3.

The data recovery process for 10 Mbits/s mode is identical to that of the 100 Mbits/s mode. As mentioned in the Manchester Decoder section, the data recovery process inherently performs decoding of Manchester encoded data from the TP inputs.

1.2.11 Link Integrity and AutoNegotiation

The device can be configured to implement either the standard link integrity algorithms or the AutoNegotiation algorithm.

The standard link integrity algorithms are used solely to establish a link to and from a remote device. The AutoNegotiation algorithm is used to establish a link to and from a remote device *and* automatically configure the device for 10 or 100 Mbits/s and Half or Full Duplex operation. The different standard link integrity algorithms for 10 and 100 Mbits/s modes are described in following subsections.

The AutoNegotiation algorithm in the device meets all requirements specified in IEEE 802.3.

AutoNegotiation is only specified for 100BASE-TX and 10BASE-T operation, and must be disabled when the device is placed in 100BASE-FX mode.

1.2.11.1 10BASE-T LINK INTEGRITY ALGORITHM (10 MBITS/S)

The device implements the same 10BASE-T link integrity algorithm defined in IEEE 802.3. This algorithm uses normal link pulses (NLPs), which are transmitted during idle periods, to determine if a device has successfully established a link with a remote device (called Link Pass state). The transmit link pulse meets the template requirements defined in IEEE 802.3 and shown in Figure 1.6. Refer to IEEE 802.3 for more details if needed.

Figure 1.6 Link Pulse Output Voltage Template (10 Mbits/s)

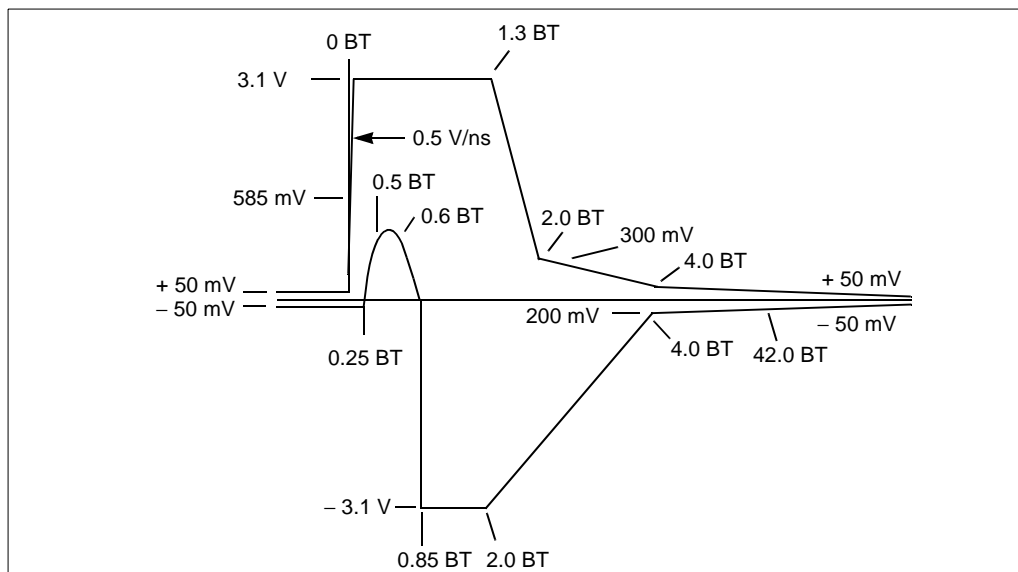

1.2.11.2 100BASE-TX LINK INTEGRITY ALGORITHM (100 MBITS/S)

Because the IEEE 802.3 specification defines 100BASE-TX to have an active idle signal, there is no need to have separate link pulses such as those defined for 10BASE-T. The LAN83C183 uses the squelch criteria and descrambler synchronization algorithm on the input data to determine if the device has successfully established a link with a remote device (called Link Pass state). Refer to IEEE 802.3 for more details if needed.

1.2.11.3 AUTONEGOTIATION ALGORITHM

As stated previously, the AutoNegotiation algorithm is used for two purposes:

- To establish a link to and from a remote device
- To automatically configure the device for either 10 or 100 Mbits/s operation and either Half- or Full-Duplex operation.

The AutoNegotiation algorithm is the same algorithm defined in IEEE 802.3 Clause 28. AutoNegotiation uses a burst of link pulses, called fast link pulses (FLPs), to pass up to 16 bits of signaling data back and forth between the LAN83C183 and a remote device. The transmit FLP pulses meet the template specified in IEEE 802.3 and

shown in Figure 1.6. A timing diagram contrasting NLPs and FLPs is shown in Figure 1.7.

Figure 1.7 NLP vs FLP Link Pulse

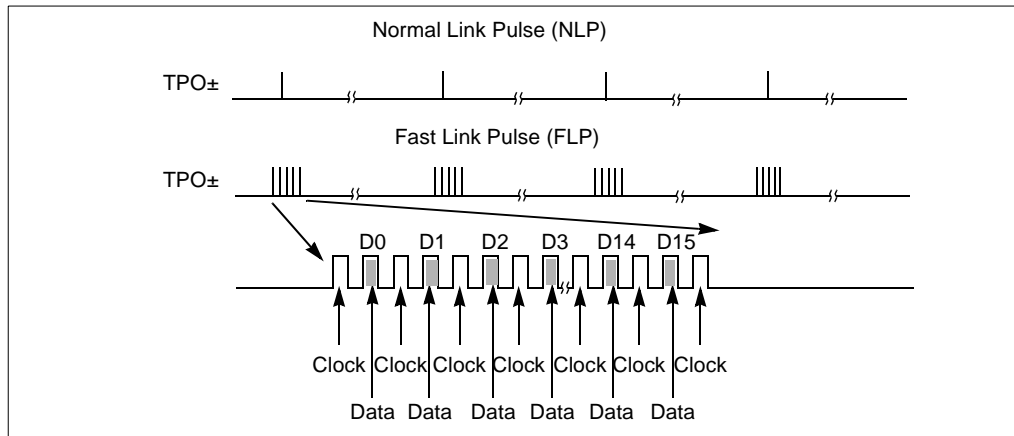

Any of the following events initiates the AutoNegotiation algorithm:

- Power up
- Device reset
- The AutoNegotiation Enable (ANEG_EN) bit in the MI serial port Control register for that port is cleared, then set
- The AutoNegotiation Reset (ANEG_RST) bit in the MI serial port Control register is set
- The channel enters the Link Fail state

Once a negotiation has been initiated, the device first determines if the remote device has AutoNegotiation capability. If the remote device is not AutoNegotiation capable and is just transmitting either 10BASE-T or 100BASE-TX signals, the device senses it and places itself in the same mode as the remote device.

If the device detects FLPs from the remote device, the remote device is determined to have AutoNegotiation capability, and the device then uses the contents of the MI serial port AutoNegotiation Advertisement register for that port to advertise its capabilities to the remote device.

The remote device does the same, and the capabilities read back from the remote device are stored in the MI serial port AutoNegotiation Remote End Capability register. The LAN83C183 negotiation algorithm then matches its capabilities to the remote device's capabilities and determines the device configuration according to the priority resolution algorithm defined in IEEE 802.3 Clause 28.

When the negotiation process is completed, the LAN83C183 then configures itself for either 10 or 100 Mbits/s mode and either Full- or Half-Duplex modes (depending on the outcome of the negotiation process), and it switches to either the 100BASE-TX or 10BASE-T link integrity algorithms (depending on which mode was enabled through AutoNegotiation). Refer to IEEE 802.3 Clause 28 for more details.

1.2.11.4 AUTONEGOTIATION OUTCOME INDICATION

The outcome or result of the AutoNegotiation process is stored in the 10/100 Speed Detect (SPD_DET) and Duplex Detect (DPLX_DET) bits in the MI serial port Status Output register.

1.2.11.5 AUTONEGOTIATION STATUS

To monitor the status of the AutoNegotiation process, simply read the AutoNegotiation Acknowledgement (ANEG_ACK) bit in the MI serial port Status register. The ANEG_ACK bit is 1 when an AutoNegotiation has been initiated and successfully completed.

1.2.11.6 AUTONEGOTIATION ENABLE

To enable the AutoNegotiation algorithm, set the AutoNegotiation Enable bit (ANEG_EN) in the MI serial port Control register, or assert the ANEG pin. To disable the AutoNegotiation algorithm, clear the ANEG_EN bit, or deassert the ANEG pin.

When the AutoNegotiation algorithm is enabled, the device halts all transmissions including link pulses for 1200 to 1500 ms, enters the Link Fail State, and restarts the negotiation process. When the AutoNegotiation algorithm is disabled, the selection of 100 Mbits/s or

10 Mbits/s mode is determined with the SPEED bit in the MI serial port Control register, and the selection of Half- or Full-Duplex mode determined from the state of the DPLX bit in the MI serial port Control register.

1.2.11.7 AUTONEGOTIATION RESET

Appropriately setting the AutoNegotiation Reset (ANEG_RST) bit in the MI serial port Control register can initiate or reset the AutoNegotiation algorithm at any time.

1.2.12 Link Indication

Receive link detect activity can be monitored through the Link Detect bit (LINK) in the MI serial port Status register and the Link Fail Detect bit (LNK_FAIL) in the Status Output register. Link detect activity can also be programmed to appear on the PLED3n or PLED0n pins. To do this, appropriately set the Programmable LED Output Select bits in the MI serial port Configuration 2 register as shown in Table 1.9. When either the PLED3n or PLED0n pins are programmed to be a link detect output, they are asserted LOW whenever the device is in the Link Pass State.

The PLED3 output is an open-drain pin with pullup resistor and can drive an LED from V_{DD} . The PLED0 output has both pullup and pulldown driver transistors in addition to a weak pullup resistor, so it can drive an LED from either V_{DD} or GND. Both the PLED3n and PLED0n outputs can also drive another digital input. Refer to Section 1.2.14, "LED Drivers," page 1-36 for a description on how to program the PLED[3:0]n pins and their default values.

1.2.13 Collision

Collisions occur whenever transmit and receive operations occur simultaneously while the device is in Half-Duplex mode.

1.2.13.1 100 MBITS/S

In 100 Mbps/s operation, a collision occurs and is sensed whenever there is simultaneous transmission (packet transmission on TPO+/-) and reception (non-idle symbols detected at the TPI+/- input). When a collision is detected, the COL output is asserted, TP data continues to be transmitted on the twisted-pair outputs, TP data continues to be received on the twisted-pair inputs, and internal CRS loopback is disabled. After a collision is in process, CRS is asserted and stays asserted until the receive and transmit packets that caused the collision are terminated.

The collision function is disabled if the device is in the Full-Duplex mode, is in the Link Fail state, or if the device is in the diagnostic loopback mode.

1.2.13.2 10 MBITS/S

A collision in the 10 Mbps/s mode is identical to one the 100 Mbps/s mode except:

- The 10 Mbps/s squelch criteria determines reception
- The RXD[3:0] outputs are all forced LOW
- The collision signal (COL) is asserted when the SQE test is performed
- The collision signal (COL) is asserted when the jabber condition has been detected.

1.2.13.3 COLLISION TEST

To test the Controller Interface collision signal (COL), set the COLTST bit in the MI serial port Control register. When this bit is set, TX_EN is looped back onto COL and the TP outputs are disabled.

1.2.13.4 COLLISION INDICATION

Collisions are indicated through the COL pin, which is asserted HIGH every time a collision occurs. The device can also be programmed to indicate collisions on the PLED2n output.

In the MI serial port Configuration 2 register, set the LED function select bits (LED_DEF_[1:0]) so that collision activity is indicated at the PLED2n output. Set the PLED2_[1:0] bits in the same register to 0b11 (normal). With these settings, a LED connected to the PLED2n pin will reflect collision activity.

When the PLED2n pin is programmed to be a collision detect output, it is asserted LOW for 100 ms every time a collision occurs. The PLED2n output is open drain with a pullup resistor and can drive an LED from V_{DD} or can drive another digital input.

See Section 1.2.14, "LED Drivers," page 1-36 for more details on how to program the LED output pins to indicate various conditions.

1.2.14 LED Drivers

The PLED[5:2]_n outputs are open-drain with a pullup resistor and can drive LEDs tied to V_{DD}. The PLED[1:0]_n outputs have both pullup and pulldown driver transistors with a pullup resistor, so the PLED[1:0]_n outputs can drive LEDs tied to either V_{DD} or GND.

The PLED[5:0]_n outputs can be programmed through the MI serial port Configuration 2 register for the following functions:

- Normal Function
- On
- Off
- Blink

The PLED[5:0]_n outputs are programmed with the LED output select bits (PLED_[1:0]) and the LED Normal Function select bits (LED_DEF[1:0]) in the MI serial port Configuration register.

1.2.14.1 LED OUTPUT SELECT BITS

There are four sets of output select bits in MI serial port Configuration register, one set for each LED output pin:

- PLED3_[1:0] control the PLED3_n output
- PLED2_[1:0] control the PLED2_n output
- PLED1_[1:0] control the PLED1_n output
- PLED0_[1:0] control the PLED0_n output

The PLEDx_[1:0] bits program the outputs to operate in the following modes:

- Normal operation (see Section 1.2.14.2, “LED Normal Function Select Bits”)
- Blink
- Steady On (PLED[3:0]_n pin LOW)
- Steady Off (PLED[3:0]_n pin HIGH)

Table 1.8 shows the encoding of the output select bits.

Table 1.8 PLED_[1:0] Output Select Bit Encoding

PLED_[1]	PLED_[0]	LED State	LED Pin
1	1	Normal	LED pin reflects the functions selected with the LED_DEF[1:0] bits
1	0	LED Blink	LED output driver continuously toggles at a rate of 100 ms on, 100 ms off
0	1	LED On	LED output driver is LOW
0	0	LED Off	LED output driver is HIGH

1.2.14.2 LED NORMAL FUNCTION SELECT BITS

When the PLED[5:0]_n pins are programmed for their normal functions (PLED_[1:0] = 0b11), the pin output states indicate four specific types of events. The LED Normal

Function select bits (LED_DEF[1:0]) in the MI serial port Configuration register determine the states of the pins, as indicated in Table 1.9 and Table 1.10.

Table 1.9 LED Normal Function Definition

LED_DEF[1:0]	PLED5n	PLED4n	PLED3n	PLED2n	PLED1n	PLED0n
0b11	RCV ACT	XMT ACT	LINK	COL	FDX	10/100
0b10	RCV ACT	XMT ACT	LINK	ACT	FDX	10/100
0b01	RCV ACT	XMT ACT	LINK + ACT	COL	FDX	10/100
0b00 ¹	RCV ACT	XMT ACT	LINK 100	ACT	FDX	LINK10

1. The LAN83C183 powers up with the LED_DEF[1:0] bits set to the default value of 0b00.

The default Normal Functions for PLED[5:0]n are Receive Activity, Transmit Activity, Link 100, Activity, Full Duplex, and Link 10, respectively.

Table 1.10 LED Event Definition

Symbol	Definition
RCV ACT	Receive activity occurred, stretch pulse to 100 ms
XMT ACT	Transmit activity occurred, stretch pulse to 100 ms
LINK	100 or 10 Mbits/s link detected
LINK+ACT	100 or 10 Mbits/s link detected or activity occurred, stretch pulse to 100 ms (link detect causes LED to be on, activity causes LED to blink)
ACT	Activity occurred, stretch pulse to 100 ms
LINK100	100 Mbit/s link detected
COL	Collision occurred, stretch pulse to 100 ms
FDX	Full-Duplex mode enabled
10/100	10 Mbits/s mode enabled (HIGH), or 100 Mbits/s mode enabled (LOW)
LINK10	10 Mbits/s link detected

1.3 START OF PACKET

This section describes start of packet operation for both the 100 Mbits/s and 10 Mbits/s modes.

1.3.1 100 Mbits/s

A unique Start of Stream Delimiter (SSD) indicates the start of packet for 100 Mbits/s mode. The SSD pattern consists of two /J/K/ 5B symbols inserted at the beginning of the packet in place of the first two preamble symbols, as defined in IEEE 802.3 Clause 24 and shown in Table 1.4 and Figure 1.2.

The 4B5B encoder generates the transmit SSD and inserts the /J/K/ symbols at the beginning of the transmit data packet in place of the first two 5B symbols of the preamble, as shown in Figure 1.2.

The 4B5B decoder detects the receive pattern. To do this, the decoder examines groups of 10 consecutive code bits (two 5B words) from the descrambler. Between packets, the receiver detects the idle pattern (5B // symbols). When in the idle state, the device deasserts the CRS and RX_DV pins.

If the receiver is in the idle state and 10 consecutive code bits from the receiver consist of the /J/K/ symbols, the start of packet is detected, data reception begins, and /5/5/ symbols are substituted in place of the /J/K/ symbols.

If the receiver is in the idle state and 10 consecutive code bits from the receiver are a pattern that is neither //// nor /J/K/ symbols, but contain at least two noncontiguous zeros, activity is detected but the start of packet is considered to be faulty and a False Carrier Indication (also referred to as bad SSD) is signaled to the controller interface.

When False Carrier is detected, CRS is asserted, RX_ER is asserted, RX_DV remains deasserted, the RXD[3:0] output state is 0b1110 while RX_ER is asserted, and the Start of Stream Error bit (SSD) is set in the MI serial port Status Output register. Once a False Carrier Event is detected, the idle pattern (two //// symbols) must be detected before any new SSDs can be sensed.

If the receiver is in the idle state and 10 consecutive code bits from the receiver consist of a pattern that is neither //// nor /J/K/ symbols but does not contain at least two noncontiguous zeros, the data is ignored and the receiver stays in the idle state.

1.3.2 10 Mbits/s

Because the idle period in 10 Mbits/s mode is defined to be when there is no valid data on the TP inputs, the start of packet for 10 Mbits/s mode is detected when the TP squelch circuit detects valid data. When the start of packet is detected, CRS is asserted as described in Section 1.2.2, "Controller Interface," page 1-16. See Section 1.2.8.4, "Squelch (10 Mbits/s)," page 1-29 for details on the squelch algorithm.

1.4 END OF PACKET

This section describes end of packet operation for both the 100 Mbits/s and 10 Mbits/s modes.

1.4.1 100 Mbits/s

The End of Stream Delimiter (ESD) indicates the end of packet for 100 Mbits/s mode. The ESD pattern consists of two /T/R/ 4B5B symbols inserted after the end of the packet, as defined in IEEE 802.3 Clause 24 and shown in Table 1.4 and Figure 1.2.

The 4B5B encoder generates the transmit ESD and inserts the /T/R/ symbols after the end of the transmit data packet, as shown in Figure 1.2.

The 4B5B decoder detects the ESD pattern when there are groups of 10 consecutive code bits (two 5B words) from the descrambler during valid packet reception.

If the 10 consecutive code bits from the receiver during valid packet reception consist of the /T/R/ symbols, the end of packet is detected, data reception is terminated, the CRS and RX_DV pins are asserted, and /I/I/ symbols are substituted in place of the /T/R/ symbols.

If 10 consecutive code bits from the receiver during valid packet reception do not consist of /T/R/ symbols, but instead consist of /I/I/ symbols, the packet is considered to have been terminated prematurely and abnormally, and the end of packet condition is signalled to the controller interface.

When the premature end of packet condition is detected, the RX_ER signal is asserted for the nibble associated with the first /I/ symbol detected, then the CRS and RX_DV pins are deasserted.

The device also sets End of Stream Error bit (ESD) in the MI serial port Status Output register to indicate the premature end of packet condition.

1.4.2 10 Mbits/s

The end of packet for 10 Mbits/s mode is indicated with the SOI (Start of Idle) pulse. The SOI pulse is a positive double wide pulse containing a Manchester code violation inserted at the end of every packet.

The TP transmitter generates the transmit SOI pulse and inserts it at the end of the data packet after TX_EN has been deasserted. The transmit waveshaper shapes the transmitted SOI output pulse at the TP output to meet the pulse template requirements specified in IEEE 802.3 Clause 14 and shown in Figure 1.8.

Figure 1.8 SOI Output Voltage Template - 10 Mbits/s

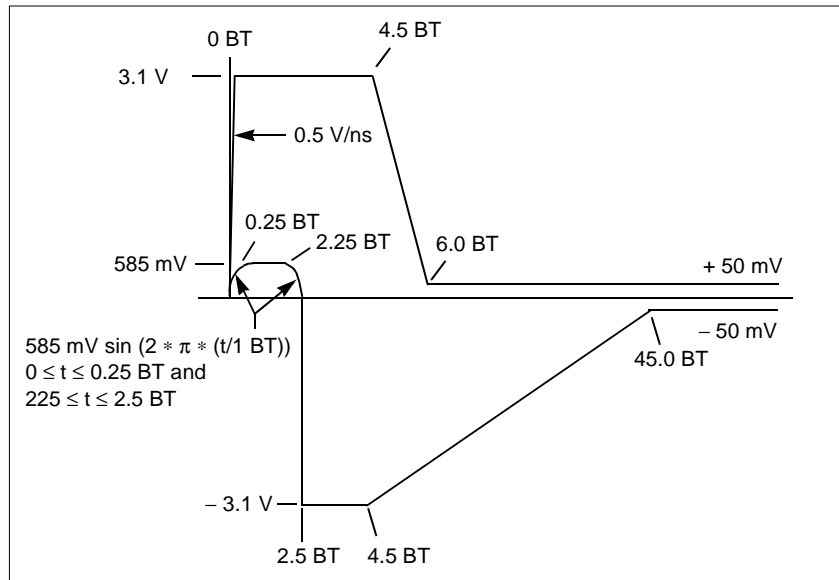

The TP receiver senses missing data transitions in order to detect the receive SOI pulse. Once the SOI pulse is detected, data reception is ended and the CRS and RX_DV pins are deasserted.

1.5 FULL/HALF DUPLEX MODE

Half-Duplex mode is the CSMA/CD operation defined in IEEE 802.3. It allows transmission or reception, but not both at the same time. Full-Duplex operation is a mode that allows simultaneous transmission and reception. Full duplex in the 10 Mbits/s mode is identical to operation in the 100 Mbits/s mode.

The device can be forced into either the Full- or Half-Duplex mode, or the device can use AutoNegotiation to autoselect Full/Half-Duplex operation. When the device is placed in Full-Duplex mode:

- The collision function is disabled, and
- TX_EN to CRS loopback is disabled

1.5.1 Forcing Full/Half Duplex Operation

To independently force a channel into either the Full- or Half-Duplex mode, set the Duplex Mode Select (DPLX) bit in the MI serial port Control register, or assert the DPLX pin, assuming that AutoNegotiation is not enabled with the ANEG_EN bit in the MI serial port Control register.

The device automatically configures itself for Full- or Half-Duplex mode. To do this, the device uses the AutoNegotiation algorithm to advertise and detect Full and Half Duplex capabilities to and from a remote device. To enable AutoNegotiation, set the AutoNegotiation Enable (ANEG_EN) bit in the MI serial port Control register or assert the ANEG pin.

To select the advertised Full/Half Duplex capability, appropriately set the bits in the MI serial port AutoNegotiation Advertisement register. AutoNegotiation functionality is described in more detail in Section 1.2.11, “Link Integrity and AutoNegotiation”.

1.5.2 Full/Half Duplex Indication

Full Duplex detection can be monitored through the Duplex Detect bit (DPLX_DET) in the MI serial port Status Output register.

The device can also be programmed such that the Full-Duplex indication appears on the PLED1n pin. To do this, appropriately set the Programmable LED Output Select bits in the MI serial port Configuration 2 register as described in Table 1.9. When the PLED1n pin is programmed to be a Full-Duplex detect output, it is asserted LOW when the device is configured for Full Duplex operation. The PLED1 output has both pullup and pulldown driver transistors and a weak pullup resistor, so it can drive an LED from either V_{DD} or GND and can also drive a digital input.

1.5.3 Loopback

1.5.3.1 INTERNAL CRS LOOPBACK

TX_EN is internally looped back onto CRS during every transmit packet. This internal CRS loopback is disabled during collision, in Full-Duplex mode, in the Link Fail State, and when the Transmit Disable bit (XMT_DIS) is set in the MI serial port Configuration 1 register. In 10 Mbits/s mode, internal CRS loopback is also disabled when jabber is detected.

1.5.3.2 DIAGNOSTIC LOOPBACK

Setting the loopback bit (LPBK) in the MI serial port Control register selects the diagnostic loopback mode. When diagnostic loopback is enabled, the TXD[3:0] data is looped back onto RXD[3:0], TX_EN is looped back onto CRS, RX_DV operates normally, the TP receive and transmit paths are disabled, the transmit link pulses are

halted, and the Half/Full Duplex modes do not change. Diagnostic loopback cannot be enabled when in the FBI mode (see Section 1.2.2.2, “FBI Interface,” page 1-19).

1.6 REPEATER MODE

The LAN83C183 uses the standard MII as the physical interface for MII-based repeater cores.

The LAN83C183 has one predefined repeater mode. To enable this mode, assert the RPTR pin. When this repeater mode is enabled with the RPTR pin:

- TX_EN to CRS loopback is disabled
- AutoNegotiation is disabled
- 100 Mbits/s operation is enabled
- Half-Duplex operation is enabled

Note: Enabling the repeater mode with the RPTR pin is only one of many possible repeater modes available on the device. Other repeater modes are available when appropriate register bits are set to enable or disable the desired functions for a given repeater mode type.

For additional information, see ?Application Note?.

1.7 10/100 MBITS/S SELECTION

The device can be forced into either the 10 or 100 Mbits/s mode, or it can use AutoNegotiation to autoselect 10 or 100 Mbits/s operation.

1.7.1 Forcing 10/100 Mbits/s Operation

To independently force each channel into either the 10 Mbits/s or 100 Mbits/s mode:

- Clear the ANEG_EN bit in the MI serial port Control register, and
- Appropriately set the Speed Select (SPEED) bit in the MI serial port Control register.

Alternatively, if the ANEG pin is LOW, the SPEED pin controls the speed. Asserting the SPEED pin HIGH forces 100 Mbits/s operation and deasserting it LOW forces 10 Mbits/s operation.

1.7.2 Autoselecting 10/100 Mbits/s Operation

The device can automatically configure itself for 10 or 100 Mbits/s mode. To do this, it uses the AutoNegotiation algorithm to advertise and detect 10 and 100 Mbits/s capabilities to and from a remote device. Setting the AutoNegotiation Enable (ANEG_EN) bit in the MI serial port Control register enables AutoNegotiation. Appropriately setting the bits in the MI serial port AutoNegotiation Advertisement register selects the advertised speed capability. AutoNegotiation functionality is described in more detail in Section 1.2.11, “Link Integrity and AutoNegotiation”.

1.7.3 10/100 Mbits/s Indication

The device can be programmed such that the operation speed (10 or 100 Mbits/s) appears on the PLED0n pin. To do this, appropriately set the Programmable LED Output Select bits in the MI serial port Configuration 2 register as described in Table 1.9. When the PLED0n pin is programmed to be speed detect output, it is asserted LOW when the device is configured for 100 Mbit/s operation. The PLED0n output has both pullup and pulldown driver transistors and a weak pullup resistor, so it can drive an LED from either V_{DD} or GND and can also drive a digital input.

1.8 JABBER

A jabber condition occurs in 10 Mb/s mode when the transmit packet exceeds a predetermined length. When jabber is detected, the TP transmit outputs are forced to the idle state, a collision is asserted, the JAB register bit is set in the MI serial port Status register, and the JAB bit is set in the MI serial port Status Output register.

To disable the jabber function, set the Jabber Disable bit (JAB_DIS) in the MI serial port Configuration 2 register

The jabber function is disabled in the 100 Mb/s mode.

1.9 AUTOMATIC JAM

This section describes automatic JAM operation for both 100 and 10 Mb/s operation.

1.9.1 100 Mb/s JAM

The LAN83C183 has an automatic JAM feature that causes the device to automatically transmit a JAM packet if receive activity is detected. If automatic JAM is enabled, the following JAM packet is transmitted on TPO± when the RX_EN/JAMn pin is asserted LOW and receive activity is detected on the TP inputs (expressed in 5B code words):

/J/K/5/5/5/5/5/5/5/5/5/5/5/5/D/H/H/H/H/H/H/H/T/R/

This automatic JAM feature is enabled when the RX_EN/JAM pin is programmed to be a JAM input. To configure the RX_EN/JAMn pin as a JAMn input, set the R/J_CFG bit in the MI serial port Configuration 2 register.

1.9.2 10 Mb/s JAM

The JAM feature for the 10 Mb/s mode is identical to that of the 100 Mb/s mode except that the JAM packet transmitted on TPO± consists of the standard 62-bit preamble (alternating 1s and 0s) followed with the SFD pattern (0b11), which is then followed with 32 bits of alternating 1s and 0s.

1.10 RESET

The device is reset when:

1. V_{DD} is applied to the device, or
2. The reset bit (RST) is set in the MI serial port Control register, or
3. The RESETn pin is asserted (LOW).

When reset occurs because of (1) or (2), an internal power-on reset pulse is generated that resets all internal circuits, forces the MI serial port bits to their default values, and latches in new values for the MI address. After the power-on reset pulse has finished, the reset bit (RST) in the MI serial port Control register is cleared and the device is ready for normal operation.

When reset is initiated because of (3), the same procedure occurs except the device stays in the reset state as long as the RESETn pin is held LOW. The RESETn pin has an internal pullup to V_{DD} . The device is guaranteed to be ready for normal operation 50 ms after the reset sequence is initiated.

1.11 POWERDOWN

To powerdown the LAN83C183, set the Powerdown bit (PDN) in the MI serial port Control register. In powerdown mode, the TP outputs are in a high-impedance state, all functions are disabled except the MI serial port, and the power consumption is reduced to a minimum. The device is guaranteed to be ready for normal operation 500 ms after the PDN bit is cleared.

1.12 RECEIVE POLARITY CORRECTION

In 10 Mbits/s mode, the polarity of the signal on the TP receive input is continuously monitored. If either three consecutive link pulses or one SOI pulse indicates incorrect polarity on the TP receive input, the polarity is internally determined to be incorrect. In this case, the Reverse Polarity Detect bit (RPOL) is set in the MI serial port Status Output register.

The device automatically corrects for the reverse polarity condition, provided the autopolarity feature is not disabled. To disable autopolarity, set the Autopolarity Disable bit (APOL_DIS) in the MI serial port Configuration 2 register.

No polarity detection or correction is needed in the 100 Mbits/s mode.

Chapter 2

Signal Descriptions

This chapter describes the device signals. It contains the following sections:

- Section 2.1, “Media Interface Signals”
- Section 2.2, “Controller Interface Signals (MII)”
- Section 2.3, “Management Interface”
- Section 2.4, “Miscellaneous Signals”
- Section 2.5, “LEDs”
- Section 2.6, “Power Supply”

Figure 2.1 is a logic diagram for the device.

Figure 2.1 Device Logic Diagram

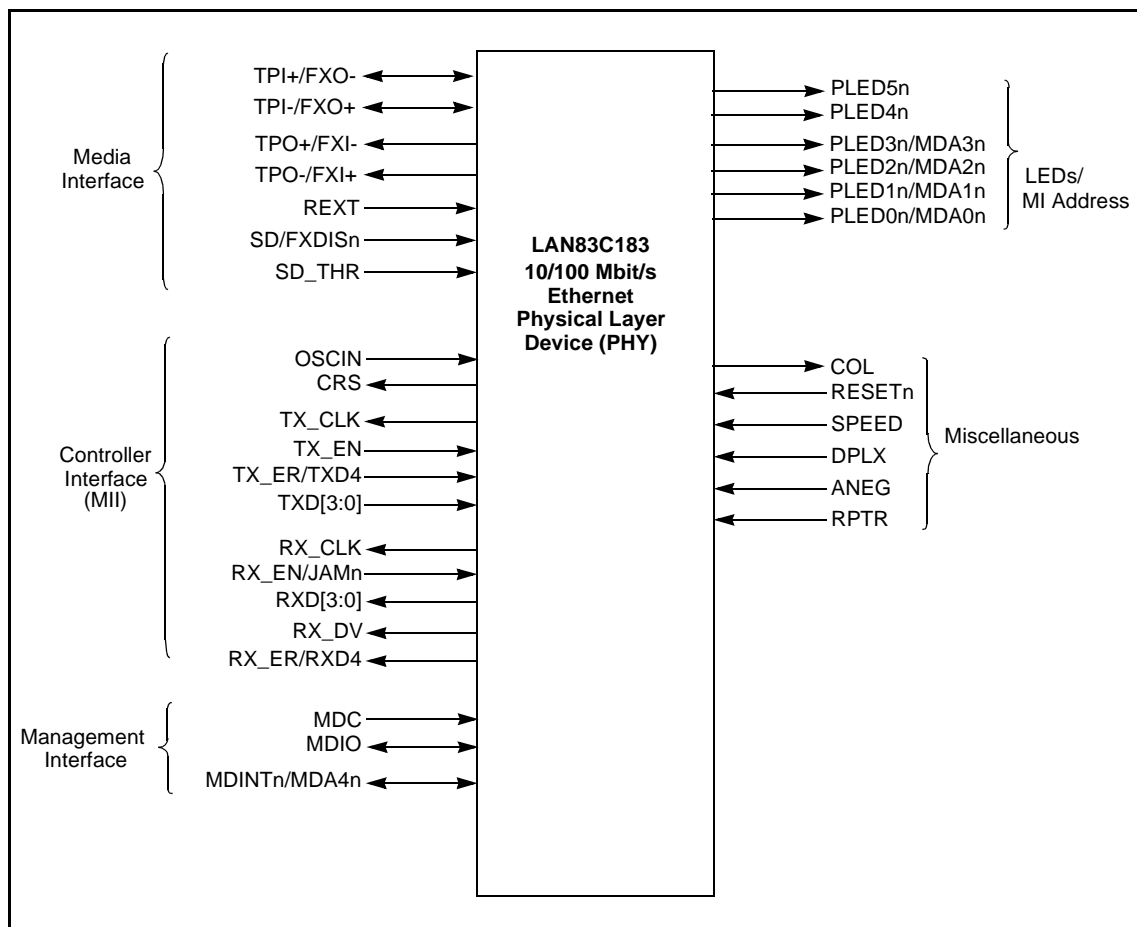

2.1 MEDIA INTERFACE SIGNALS

REXT	Transmit Current Set An external resistor connected between the REXT pin and GND sets the output current for the TP and FX transmit outputs.	I/O
SD/FXDISn	FX Signal Detect Input/FX Interface Disable When this pin is not tied to GND, the FX interface is enabled and this pin becomes an ECL signal detect input. The voltage on SD_THR determines the trip point for this ECL input. When this pin is tied to GND, the FX interface is disabled and the TP interface is enabled.	I
SD_THR	Signal Detect Input Threshold Level Set The voltage on this pin determines the ECL threshold level (trip point) for the SD input pin so that the device can directly interface to both 3.3 V and 5 V fiber optic transceivers. Typically, this pin is either tied to GND (for 3.3 V operation) or to an external voltage divider (for 5 V operation).	I
TPO+/FXI-	Twisted-Pair Transmit Output (Positive), or Fiber Optic Receive Input (Negative) The TPO+/FXI- pin is shared for the twisted-pair and fiber optic signals. It functions as the positive signal in the twisted-pair output or the negative signal in the fiber optic input.	I/O
TPO-/FXI+	Twisted-Pair Transmit Output (Negative), or Fiber Optic Receive Input (Positive) The TPO-/FXI+ pin is shared for the twisted-pair and fiber optic signals. It functions as the negative signal in the twisted-pair output or the positive signal in the fiber optic input.	I/O
TPI+/FXO-	Twisted-Pair Receive Input (Positive), or Fiber Optic Transmit Output (Negative) The TPI+/FXO- pin is shared for the twisted-pair and fiber optic signals. It functions as the positive signal in the twisted-pair input or the negative signal in the fiber optic output.	I/O
TPI-/FXO+	Twisted-Pair Receive Input (Negative), or Fiber Optic Output (Positive) The TPI-/FXO+ pin is shared for the twisted-pair and fiber optic signals. It functions as the negative signal in the twisted-pair input or the positive signal in the fiber optic output.	I/O

2.2 CONTROLLER INTERFACE SIGNALS (MII)

CRS	Carrier Sense Output	O
	The CRS output is asserted HIGH when valid data is detected on the receive TP inputs. CRS is clocked out on the falling edge of RX_CLK.	
OSCIN	Clock Oscillator Input	I
	There must be either a 25 MHz crystal between this pin and GND or a 25 MHz clock applied to this pin. TX_CLK output is generated from this input.	
RX_CLK	Receive Clock Output	O
	Receive data on RXD, RX_DV, and RX_ER is clocked out to an external controller on the falling edge of RX_CLK.	
RXD[3:0]	Receive Data Output	O
	RXD[3:0] contain receive nibble data from the TP input, and they are clocked out on the falling edge of RX_CLK.	
RX_DV	Receive Data Valid Output	O
	RX_DV is asserted HIGH when valid decoded data is present on the RXD outputs. RX_DV is clocked out on the falling edge of RX_CLK.	
RX_EN/JAMn	Receive Enable Input	I
	The function of this pin is configured through the R/J Configuration Select bit (R/J_CFG) in the MI serial port Configuration 1 register. When R/J_CFG is set, the pin is configured as JAMn; when it is cleared, the pin functions as RX_EN	
	RX_EN function: when RX_EN is HIGH, all of the receive outputs (RX_CLK, RXD[3:0], RX_DV, RX_ER, COL) are enabled. When RX_EN is LOW, the outputs are in a high-impedance state.	
	JAMn function: when JAMn is HIGH, a JAM packet is transmitted when receive activity is detected. When JAMn is LOW, no JAM packet is transmitted.	
RXER/RXD4	Receive Error Output/Fifth Receive Data Output	O
	The RXER/RXD4 output is asserted HIGH when a coding error or other specified errors are detected on the receive twisted-pair inputs. The signal is clocked out on the falling edge of RX_CLK.	
	If the device is placed in the Bypass 4B5B Decoder mode (the BYP_ENC bit is set in the MI serial port Configuration 1 register), this pin is reconfigured to be the fifth RXD receive data output, RXD4.	
TX_CLK	Transmit Clock Output	O
	Transmit data from the controller on TXD, TX_EN, and TX_ER is clocked in on the rising edge of TX_CLK and OSCIN.	
TXD[3:0]	Transmit Data Input	I
	TXD[3:0] contain input nibble data to be transmitted on the TP outputs, and they are clocked in on the rising edge of TX_CLK and OSCIN when TX_EN is asserted.	

TX_EN	Transmit Enable Input	I
	TX_EN must be asserted HIGH to indicate that data on TXD and TX_ER is valid. TX_ER is clocked in on the rising edge of TX_CLK and OSCIN.	
TX_ER/TXD4	Transmit Error Input/Fifth Transmit Data Input	I
	The TXER pin, when asserted, causes a special pattern to be transmitted on the twisted-pair outputs in place of normal data, and it is clocked in on the rising edge of TX_CLK when TX_EN is asserted.	
	If the device is placed in the Bypass 4B5B Encoder mode (the BYP_ENC bit is set in the MI serial port Configuration 1 register), this pin is reconfigured to be the fifth TXD transmit data input, TXD4.	

2.3 MANAGEMENT INTERFACE

MDC	MI Clock	I
	The MDC clock shifts serial data for the internal registers into and out of the MDIO pin on its rising edge.	
MDINTn/MDA4n	Management Interface Interrupt Output/Management Interface Address Input Pullup O.D. I/O	
	This pin is an interrupt output and is asserted LOW whenever there is a change in certain MI serial port register bits. The pin is deasserted after all changed bits have been read out.	
	During powerup or reset, this pin is high impedance and the state of the pin is latched in as the physical device address MDA4 for the MI serial port.	
MDIO	MI Data	I/O
	This bidirectional pin contains serial data for the internal registers. The data on this pin is clocked in and out of the device on the rising edge of MDC.	

2.4 MISCELLANEOUS SIGNALS

ANEG	AutoNegotiation Input	I
	This pin control AutoNegotiation operation.	
	ANEG Pin	Meaning
	HIGH	AutoNegotiation is on. AutoNegotiation Enable is controlled from the ANEG_EN bit, 10/100 Mbits/s operation is controlled from the SPEED bit, and Half/Full Duplex operation is controlled from the DPLX bit.
	LOW	AutoNegotiation is off. 10/100 Mbits/s operation is controlled from the SPEED pin and Half/Full Duplex operation is controlled from the DPLX pin.

2.5 LEADS

PLED5n Receive LED Output Pullup O.D. O
 The function of this pin is to be a Receive Activity Detect output. The pin can drive an LED from V_{DD} .

PLED5n	
Pin	Function
HIGH	No receive activity
LOW	Receive packet occurred (held LOW for 100 ms)

PLED4n Transmit LED Output Pullup O.D. O
 The function of this pin is to be a Transmit Activity Detect output. The pin can drive an LED from V_{DD} .

PLED4n	
Pin	Function
HIGH	No transmit activity
LOW	Transmit packet occurred (held LOW for 100 ms)

PLED3n/MDA3n

Programmable LED Output/MI Address Bit Pullup O.D. I/O

The default function of this pin is to be a 100 Mb/s Link Detect output. This pin can also be programmed through the MI serial port to indicate other events or be user controlled. This pin can drive an LED from V_{DD} .

When programmed as a 100 Mb/s Link Detect Output (default):

PLED3n/MDA3n	
Pin	Function
HIGH	No Link Detect
LOW	100 Mb/s Link Detected

During powerup or reset, this pin is high-impedance and the level on this pin is latched in as the physical device address MDA3n for the MI serial port.

PLED2n/MDA2n

Programmable LED Output/MI Address Bit Pullup O.D. I/O

The default function of this pin is to be an Activity Detect output. This pin can also be programmed through the MI serial port to indicate other events or be user controlled. This pin can drive an LED from V_{DD} .

When programmed as an Activity Detect Output (default):

PLED2n/MDA2n	
Pin	Function
HIGH	No Activity
LOW	Transmit or receive packet occurred (held LOW for 100 ms)

During powerup or reset, this pin is high-impedance and the level on this pin is latched in as the physical device address MDA2n for the MI serial port.

PLED1n/MDA1n

Programmable LED Output/MI Address Bit

Pullup O.D. I/O

The default function of this pin is to be a Full Duplex Detect output. This pin can also be programmed through the MI serial port to indicate other events or be user controlled. This pin can drive an LED from both V_{DD} and GND.

When programmed as Full Duplex Detect Output (default):

PLED1n/MDA1n	
Pin	Function
HIGH	Half-Duplex
LOW	Full-Duplex

During powerup or reset, this pin is high-impedance and the level on this pin is latched in as the physical address device address MDA1n for the MI serial port.

PLED0n/MDA0n

Programmable LED Output/MI Address Bit

Pullup O.D. I/O

The default function of this pin is to be a 10 Mbits/s Link Detect output. This pin can also be programmed through the MI serial port to indicate other events or be user controlled. This pin can drive an LED from both V_{DD} and GND.

When programmed as 10 Mbits/s Link Detect Output (default):

PLED0n/MDA0n	
Pin	Function
HIGH	No Detect
LOW	10 Mbits/s Link Detected

During powerup or reset, this pin is high-impedance and the value on this pin is latched in as the address MDA0n for the MI serial port.

2.6 POWER SUPPLY

GND	Ground	I
	There are six ground pins. They must be connected to ground (0 Volts).	
V_{DD}	Positive Supply	I
	There are six V_{DD} pins. They must be connected to $3.3 \pm 5\%$ Volts.	

Chapter 3

Registers

This chapter contains a description of the registers accessed over the management interface (MI) serial interface. It contains the following sections:

- Section 3.1, “Bit Types”
- Section 3.2, “MI Serial Port Register Summary”
- Section 3.3, “Registers”

For further information about the operation of the MI serial interface, see Chapter 4, Management Interface.

3.1 BIT TYPES

Because the serial port is bidirectional (capable of both read and write operations), there are many types of bits. The following bit type definitions are summarized in Table 3.1:

- Write bits (W) are inputs during a write cycle and are high impedance during a read cycle
- Read bits (R) are outputs during a read cycle and high impedance during a write cycle
- Read/Write bits (R/W) are actually write bits that can be read out during a read cycle
- R/WSC bits are R/W bits that are self-clearing after a set period of time or after a specific event has completed
- R/LL bits are read bits that latch themselves when they go LOW, and they stay LOW until read. After they are read, they are reset HIGH.
- R/LH bits are the same as R/LL bits, except that they latch HIGH.
- R/LT are read bits that latch themselves whenever they make a transition or change value, and they stay latched until they are read. After R/LT bits are read, they are updated to their current value.

Table 3.1 MI Register Bit Type Definition

Symbol	Name	Definition	
		Write Cycle	Read Cycle
W	Write	Input	No operation, Hi-Z
R	Read	No operation, Hi-Z	Output
R/W	Read/Write	Input	Output
R/WSC	Read/Write, Self-Clearing	Input	Output (clears itself after the operation completes)
R/LL	Read/Latching LOW	No operation, Hi-Z	Output When the bit goes LOW, it is latched. When the bit is read, it is updated.
R/LH	Read/Latching HIGH	No operation, Hi-Z	Output When the bit goes HIGH, it is latched. When the bit is read, it is updated.
R/LT	Read/Latching on transition	No operation, Hi-Z	Output When the bit transitions, the bit is latched. When the bit is read, the bit is updated.

3.2 MI SERIAL PORT REGISTER SUMMARY

The following tables summarize the device registers accessible through the MI serial port.

Control Register (register 0) –

15	14	13	12	11	10	9	8
RST	LPBK	SPEED	ANEG_EN	PDN	MII_DIS	ANEG_RST	DPLX
7	6	Reserved				0	
COLTST							

Status Register (register 1) –

15	14	13	12	11	10	8	
CAP_T4	CAP_TXF	CAP_TXH	CAP_TF	CAP_TH	Reserved		
7	6	5	4	3	2	1	0
Reserved	CAP_SUPR	ANEG_ACK	REM_FLT	CAP_ANEG	LINK	JAB	EXREG

PHY ID #1 Register (register 2) –

15	14	13	12	11	10	9	8
OUI3	OUI4	OUI5	OUI6	OUI7	OUI8	OUI9	OUI10
7	6	5	4	3	2	1	0
OUI11	OUI12	OUI13	OUI14	OUI15	OUI16	OUI17	OUI18

PHY ID #2 Register (register 3) –

15	14	13	12	11	10	9	8
OUI19	OUI20	OUI21	OUI22	OUI23	OUI24	PART5	PART4
7	6	5	4	3	2	1	0
PART3	PART2	PART1	PART0	REV3	REV2	REV1	REV0

AutoNegotiation Advertisement Register (register 4) –

15	14	13	12	10		9	8
NP	ACK	RF	Reserved			T4	TX_FDX
7	6	5	4	1		0	
TX_HDX	10_FDX	10_HDX	Reserved			CSMA	

AutoNegotiation Remote End Capability Register (register 5) –

15	14	13	12	10		9	8
NP	ACK	RF	Reserved			T4	TX_FDX
7	6	5	4	1		0	
TX_HDX	10_FDX	10_HDX	Reserved			CSMA	

Configuration 1 Register (register 16) –

15	14	13	12	11	10	9	8
LINK_DIS	XMT_DIS	XMT_PDN	TXEN_CRS	BYP_ENC	BYP_SCR	UNSCR_DIS	EQLZR
7	6	5	2			1	0
CABLE	RLVL0	TLVL[3:0]			TRF[1:0]		

Configuration 2 Register (register 17) –

15	14	13	12	11	10	9	8
PLED3_1	PLED3_0	PLED2_1	PLED2_0	PLED1_1	PLED1_0	PLED0_1	PLED0_0
7	6	5	4	3	2	1	0
LED_DEF1	LED_DEF0	APOL_DIS	JAB_DIS	MREG	INT_MDIO	R/J_CFG	0

Status Output Register (register 18) –

15	14	13	12	11	10	9	8
INT	LINK_FAIL	LOSS_SYNC	CWRD	SSD	ESD	RPOL	JAB
7	6	5	Reserved				0
SPD_DET	DPLX_DET	Reserved					

Mask Register (register 19)

15	14	13	12	11	10	9	8
MASK_INT	MASK_LNK_FAIL	MASK_LOSS_SYNC	MASK_CWRD	MASK_SSD	MASK_ESD	MASK_RPOL	MASK_JAB
7	6	5	4	3	Reserved		0
MASK_SPD_DET	MASK_DPLX_DET	FXLVL[1:0]		Reserved			

Reserved Register (register 20) –

15	14	13	12	11	10	9	8
Reserved							
7	6	5	Reserved				0
Reserved							

3.3 REGISTERS

This section contains a description of each of the bits in each register.

3.3.1 Control Register (Register 0)

The default value for this register is 0x3000.

15	14	13	12	11	10	9	8	
RST	LPBK	SPEED	ANEG_EN	PDN	MII_DIS	ANEG_RST	DPLX	
7	6					0		
COLTST		Reserved						

RST Reset R/WSC 15

RST Bit	Meaning
1	Reset. The bit is bit self-clearing in less than or equal to 200 μ s after reset finishes.
0	Normal (Default)

LPBK Loopback Enable R/W 14

LPBK Bit	Meaning
1	Loopback mode enabled
0	Normal (Default)

SPEED Speed Select R/W 13

SPEED Bit ¹	Meaning
1	100 Mbit/s (100BASE-TX) (default)
0	10 Mbit/s (10BASE-T)

1. The SPEED bit is effective only when AutoNegotiation is off, and the bit can be overridden with the assertion of the SPEED pin.

ANEG_EN AutoNegotiation Enable R/W 12

ANEG_EN Bit ¹	Meaning
1	1 = AutoNegotiation enabled (default)
0	0 = Disabled

1. The ANEG_EN pin can be overridden with the assertion of the ANEG pin.

PDN Power Down Enable R/W 11

PDN Bit	Meaning
1	Power down
0	Normal (default)

MII_DIS MII Interface Disable R/W 10

MII_DIS ¹ Bit	Meaning
0	MII interface disable
1	Normal (default)

1. If MDA[3:0]n is not read as 0b1111 at reset time, the MII_DIS default value is changed to 0.

ANEG_RSTAutoNegotiation Reset R/WSC 9**ANEG_RST Bit**

1	Restart AutoNegotiation process. The bit is self-clearing after reset is finished
0	Normal (default)

DPLX Duplex Mode Select R/W 8**DPLX Bit¹**

1	Full-duplex
0	Half-duplex (default)

1. This bit is effective only when AutoNegotiation is off, and the bit can be overridden with the assertion of the DPLX pin.

COLTST Collision Test Enable R/W 7**COLTST Bit**

1	Collision test enabled
0	Normal (default)

R Reserved R [6:0]

These bits are reserved and must be remain at the default value of 0x00 for proper device operation.

3.3.2 Status Register (Register 1)

The default value of this register is 0x7809.

15	14	13	12	11	10	8	
CAP_T4	CAP_TXF	CAP_TXH	CAP_TF	CAP_TH	Reserved		
7	6	5	4	3	2	1	0
Reserved	CAP_SUPR	ANEG_ACK	REM_FLT	CAP_ANEG	LINK	JAB	EXREG

CAP_T4 100BASE-T4 Capable R 15**CAP_T4****Bit Meaning**

1	Capable of 100BASE-T4 operation
0	Not capable of 100BASE-T4 Operation (default)

CAP_TXF 100BASE-TX Full Duplex Capable R 14**CAP_TXF****Bit Meaning**

1	Capable of 100BASE-TX Full-Duplex (default)
0	Not capable of 100BASE-TX Full-Duplex

CAP_TXH 100BASE-TX Half Duplex Capable R 13**CAP_TXH****Bit Meaning**

1	Capable of 100BASE-TX Half-Duplex (default)
0	Not capable of 100BASE-TX Half-Duplex

CAP_TF 10BASE-T Full Duplex Capable R 12**CAP_TF**

Bit	Meaning
1	Capable of 10BASE-T Full-Duplex (default)
0	Not capable of 10BASE-T Full-Duplex

CAP_TH 10BASE-T Half Duplex Capable R 11**CAP_TH**

Bit	Meaning
1	Capable of 10BASE-T Half Duplex (default)
0	Not capable of 10BASE-T Half Duplex

R Reserved R [10:7]

These bits are reserved and must be remain at the default value of 0x0 for proper device operation

CAP_SUPRMI Preamble Suppression Capable R 6**CAP_SUPR**

Bit	Meaning
1	Capable of accepting MI frames with preamble suppression
0	Not capable of accepting MI frames with preamble suppression (default)

ANEG_ACKAutoNegotiation Acknowledgment R 5**ANEG_ACK**

Bit	Meaning
1	AutoNegotiation acknowledgment process complete
0	AutoNegotiation not complete (default)

REM_FLT Remote Fault Detect R/LH 4**REM_FLT**

Bit	Meaning
1	Remote fault detect. The REM_FLT bit is set when the Remote Fault (RF) bit is set in the AutoNegotiation Remote End Capability register.
0	No remote fault (default)

CAP_ANEGAutoNegotiation Capable R 3**CAP_ANEG**

Bit	Meaning
1	Capable of AutoNegotiation (default)
0	Not capable of AutoNegotiation

LINK Link Status R/LL 2**LINK Bit Meaning**

1	Link detected (same as the LNK_FAIL bit inverted). See Section 3.3.9, "Status Output Register (Register 18)," page 3-68)
0	Link not detected (default)

JAB Jabber Detect R/LH 1**JAB Bit Meaning**

1	Jabber detected (same as the JAB bit in Section 3.3.9, "Status Output Register (Register 18)," page 3-68)
0	Normal (default)

EXREG Extended Register Capable R 0

EXREG Bit	Meaning
1	Extended registers exist (default)
0	Extended registers do not exist

3.3.3 PHY ID 1 Register (Register 2)

15	14	13	12	11	10	9	8
OUI3	OUI4	OUI5	OUI6	OUI7	OUI8	OUI9	OUI10
7	6	5	4	3	2	1	0
OUI11	OUI12	OUI13	OUI14	OUI15	OUI16	OUI17	OUI18

OUI[3:18] Company ID, Bits 3–18 R [15:0]

OUI[3:18] in this register and OUI[19:24] of the PHY ID 2 register make up the LSI OUI, whose default value is 0x00.A07D. The table below shows the default bit positions for the entire OUI field:

Bit	Default Value	Hex Value
OIU24	0	
OIU23	1	
OIU22	1	0x7
OIU21	1	
OIU20	1	
OIU19	1	
OIU18	0	0xD
OIU17	1	
OIU16	1	
OIU15	0	
OIU14	1	0xA
OIU13	0	
OIU12	0	
OIU11	0	
OIU10	0	0x0
OIU9	0	
OIU8	0	
OIU7	0	
OIU6	0	0x0
OIU5	0	
OIU4	0	0x0
OUI3	0	

3.3.4 PHY ID 2 Register (Register 3)

15	14	13	12	11	10	9	8
OUI19	OUI20	OUI21	OUI22	OUI23	OUI24	PART5	PART4
7	6	5	4	3	2	1	0
PART3	PART2	PART1	PART0	REV3	REV2	REV1	REV0

OUI[19:24] Company ID, Bits 19–24 R [15:10]

OUI[19:24] in this register and OUI[3:18] of the PHY ID 1 register make up the LSI OUI, whose default value is 0x00.A07D. See the table in the PHY ID 1 description for a description of the entire OUI field.

PART[5:0] Manufacturer's Part Number R [9:4]

The default value for this field is 0x04. The table below shows the default bit positions for the PART[5:0] field:

Bit	Default Value	Hex Value
PART[5]	0	
PART[4]	0	0x0
PART[3]	0	
PART[2]	1	
PART[1]	0	0x4
PART[0]	0	

REV[3:0] Manufacturer's Revision Number R [3:0]

The default value for this field is 0x0.

3.3.5 AutoNegotiation Advertisement Register (Register 4)

The default value for this register is 0x01E1.

15	14	13	12	10	9	8
NP	ACK	RF	Reserved		T4	TX_FDX
7	6	5	4		1	0
TX_HDX	10_FDX	10_HDX	Reserved			CSMA

NP Next Page Enable R 15

NP Bit Meaning

1	Next page ¹
0	No next page (default)

1. Next page is not currently supported

ACK Acknowledge R 14

ACK Bit Meaning

1	Received AutoNegotiation word recognized
0	Not recognized (default)

RF Remote Fault R/W 13

RF Bit	Meaning
1	AutoNegotiation remote fault detect
0	No remote fault detect (default)

R Reserved R/W[12:10]

These bits are reserved and must be remain at the default value of 0b00 for proper device operation

T4 100BASE-T4 Capable R/W 9

T4 Bit	Meaning
1	Capable of 100BASE-T4 operation
0	Not capable (default)

TX_FDX 100BASE-TX Full Duplex Capable R/W 8

TX_FDX Bit	Meaning
1	Capable of 100BASE-TX Full Duplex operation (default)
0	Not capable

TX_HDX 100BASE-TX Half Duplex Capable R/W 7

TX_HDX Bit	Meaning
1	Capable of 100BASE-TX Half-Duplex operation (default)
0	Not capable

10_FDX 10BASE-TX Full Duplex Capable R/W 6

10_FDX Bit	Meaning
1	Capable of 10BASE-T Full-Duplex operation (default)
0	Not capable

10_HDX 10BASE-TX Half Duplex Capable R/W 5

10_HDX Bit	Meaning
1	Capable of 10BASE-T Half-Duplex operation (default)
0	Not capable

R Reserved R/W [4:1]

These bits are reserved and must be remain at the default value of 0x0 for proper device operation

CSMA CSMA 802.3 Capable R/W 0

CSMA Bit	Meaning
1	Capable of 802.3 CSMA ¹ operation (default)
0	Not capable

1. Carrier-Sense, Multiple-Access

3.3.6 AutoNegotiation Remote End Capability Register (Register 5)

The default value for this register is 0x0000.

15	14	13	12	10	9	8
NP	ACK	RF	Reserved		T4	TX_FDX
7	6	5	4	1		0
TX_HDX	10_FDX	10_HDX	Reserved			CSMA

NP Next Page Enable R 15

NP Bit	Meaning
1	Next Page exists
0	No Next Page (default)

ACK Acknowledge R 14

ACK Bit	Meaning
1	Received AutoNegotiation Word recognized
0	Not Recognized (default)

RF Remote Fault R 13

RF Bit	Meaning
1	AutoNegotiation Remote Fault detect
0	No Remote Fault (default)

R Reserved R [12:10]

These bits are reserved and must be remain at the default value of 0b00 for proper device operation

T4 100BASE-T4 Capable R 9

T4 Bit	Meaning
1	Capable of 100BASE-T4 operation
0	Not capable (default)

TX_FDX 100BASE-TX Full Duplex Capable R 8

TX_FDX Bit	Meaning
1	Capable of 100BASE-TX Full Duplex operation
0	Not capable (default)

TX_HDX 100BASE-TX Half Duplex Capable R 7

TX_HDX Bit	Meaning
1	Capable of 100BASE-TX Half Duplex operation
0	Not capable (default)

10_FDX 10BASE-TX Full Duplex Capable R 6

10_FDX Bit	Meaning
1	Capable of 10BASE-T Full Duplex operation
0	Not capable (default)

10_HDX 10BASE-TX Half Duplex Capable R 5

10_HDX	
Bit	Meaning
1	Capable of 10BASE-T Half Duplex operation
0	Not capable (default)

R Reserved R [4:1]
 These bits are reserved and must be remain at the default value of 0x0 for proper device operation

CSMA CSMA 802.3 Capable R 0

CSMA Bit Meaning	
1	Capable of 802.3 CSMA ¹ Operation
0	Not capable (default)

1. Carrier-Sense, Multiple-Access

3.3.7 Configuration 1 Register (Register 16)

The default value for this register is 0x0022.

15	14	13	12	11	10	9	8
LNK_DIS	XMT_DIS	XMT_PDN	TXEN_CRIS	BYP_ENC	BYP_SCR	UNSCR_DI S	EQLZR
7	6	5	4	3	2	1	0
CABLE	RLVL0	TLVL3	TLVL2	TLVL1	TLVL0	TRF1	TRF0

LNK_DIS Link Disable R/W 15

LNK_DIS	
Bit	Meaning
1	Receive Link Detect function disable (Force Link Pass)
0	Normal (default)

XMT_DIS Device Reset R/WSC 14

XMT_DIS	
Bit	Meaning
1	TP transmitter disabled
0	Normal (default)

XMT_PDN TP Transmit Powerdown R/W 13

XMT_PDN	
Bit	Meaning
1	TP transmitter powered down
0	Normal (default)

TXEN_CRSTX_EN to CRS Loopback Disable R/W 12

TXEN_CRIS	
Bit	Meaning
1	TX_EN to CRS loopback disabled
0	Loopback enabled (default)

BYP_ENC Bypass Encoder/Decoder Select R/W 11**BYP_ENC**

Bit	Meaning
1	Bypass 4B/5B Encoder/Decoder
0	Normal (default)

BYP_SCR Bypass Scrambler/Descrambler Select R/W 10**BYP_SCR**

Bit	Meaning
1	Bypass Scrambler/Descrambler
0	Normal (default)

UNSCR_DIS Unscrambled Idle Reception Disabled R/W 9**UNSCR_DIS**

Bit	Meaning
1	Disable AutoNegotiation with devices that transmit unscrambled idle on powerup and various instances
0	Enable AutoNegotiation with devices that transmit unscrambled idle on powerup and various instances (default)

EQLZR Receive Equalizer Select R/W 8**EQLZR**

Bit	Meaning
1	Receive equalizer disabled (set to zero length)
0	Receive equalizer on (for 100 Mbits/s mode only) (default)

CABLE Cable Type Select R/W 7**CABLE**

Bit	Meaning
1	STP (150 Ohm)
0	UTP (100 Ohm) (default)

RLVL0 Receive Input Level Adjust R/W 6**RLVL0**

Bit	Meaning
1	Receive squelch levels reduced by 4.5 dB
0	Normal (default)

TLVL[3:0] Transmit Output Level Adjust R/W [5:2]

The transmit output current level is derived from an internal reference voltage and the external resistor on the REXT pin. The transmit level can be adjusted with either the external resistor on the REXT pin, or the four Transmit Level Adjust bits (TLVL[3:0]), as shown. The adjustment range is approximately -14% to +16% in 2% steps.

TLVL[3:0] Bits	Gain
0b0000	1.16
0b0001	1.14
0b0010	1.12
0b0011	1.10
0b0100	1.08
0b0101	1.06
0b0110	1.04
0b0111	1.02
0b1000 (default)	1.00
0b1001	0.98
0b1010	0.96
0b1011	0.94
0b1100	0.92
0b1101	0.90
0b1110	0.88
0b1111	0.86

TRF[1:0] Transmit Rise/Fall Time Adjust R/W [1:0]

TRF[1:0]	
Bits	Adjustment
0b11	-0.25 ns
0b10 (default)	+0.0 ns
0b01	+.25 ns
0b00	+.50 ns

3.3.8 Configuration 2 Register (Register 17)

The default value for this register is 0xFF00.

15	14	13	12	11	10	9	8
PLED3_1n	PLED3_0n	PLED2_1n	PLED2_0n	PLED1_1n	PLED1_0n	PLED0_1n	PLED0_0n
7	4			3	2	1	0
LED_DEF1	LED_DEF0	APOL_DIS	JAB_DIS	MREG	Reserved		

PLED3_[1:0]nProgrammable LED 3 Output SelectR/W [15:14]

PLED3_1n PLED3_0n Meaning

PLED3_1n	PLED3_0n	Meaning
1	1	Normal (PLED3n pin state is determined from the LED_DEF[1:0] bits (default is LINK100). 0b11 is the default for these bits
1	0	LED tied to PLED3n blinks (toggles 100 ms LOW, then 100 ms HIGH)
0	1	LED tied to PLED3n ON steady (PLED3n output LOW)
0	0	LED tied to PLED3n OFF steady (PLED3n output HIGH)

PLED2_[1:0]nProgrammable LED 2 Output SelectR/W [13:12]**PLED2_1n PLED2_0n Meaning**

1	1	Normal (PLED2n pin state is determined from the LED_DEF[1:0] bits (default is Activity). 0b11 is the default for these bits
1	0	LED tied to PLED2n blinks (toggles 100 ms LOW, then 100 ms HIGH)
0	1	LED tied to PLED2n ON steady (PLED2n output LOW)
0	0	LED tied to PLED2n OFF steady (PLED2n output HIGH)

PLED1_[1:0]nProgrammable LED 1 Output SelectR/W [11:10]**PLED1_1n PLED1_0n Meaning**

1	1	Normal (PLED1n pin state is determined from the LED_DEF[1:0] bits (default is Full-Duplex). 0b11 is the default for these bits
1	0	LED tied to PLED1n blinks (toggles 100 ms LOW, then 100 ms HIGH)
0	1	LED tied to PLED1n ON steady (PLED1n output LOW)
0	0	LED tied to PLED1n OFF steady (PLED1n output HIGH)

PLED0_[1:0]nProgrammable LED 0 Output SelectR/W [9:8]**PLED0_1n PLED0_0n Meaning**

1	1	Normal (PLED0n pin state is determined from the LED_DEF[1:0] bits (default is Link 10). b11 is the default for these bits
1	0	LED tied to PLED0n blinks (toggles 100 ms LOW, then 100 ms HIGH)
0	1	LED tied to PLED0n ON steady (PLED0n output LOW)
0	0	LED tied to PLED0n OFF steady (PLED0n output HIGH)

LED_DEF_[1:0]**LED Normal Function Select R/W [7:6]**

See Table 1.8 on page 1-36 for these bit definitions.

APOL_DIS Autopolarity Disable R 5

APOL_DIS	
Bit	Meaning
1	Autopolarity correction disabled
0	Normal (default)

JAB_DIS Jabber Disable R 4

JAB_DIS Bit Meaning	
1	Jabber disabled
0	Jabber enabled (default)

MREG Multiple Register Access Enable R 3

MREG Bit Meaning	
1	Multiple register access enabled
0	No multiple register access (default)

INT_MDIO Interrupt Scheme Select R/W 2

INT_MDIO	
Bit	Meaning
1	Interrupt signaled with MDIO pulse during idle
0	Interrupt not signaled on MDIO (default)

R/J_CFG R/J Configuration Select R/W 1

R/J_CFG	
Bit	Meaning
1	RX_EN/JAMn pin is configured to be JAMn
0	RX_EN/JAMn pin is configured to be RX_EN (default)

R Reserved R/W 0

This bit is reserved and must be remain at the default value of 0x0 for proper device operation.

3.3.9 Status Output Register (Register 18)

The default value for this register is 0x0080.

15	8
INT	JAB
LNK_FAIL	RPOL
LOSS_SYNC	ESD
CWRD	SSD
7	5
SPD_DET	DPLX_DET
Reserved	
0	0

INT Interrupt Detect R 15

INT	
INT Bit	Meaning
1	Interrupt bit(s) have changed since last read operation
0	No change (default)

LNK_FAIL Link Fail Detect R/LT 14

LNK_FAIL	
Bit	Meaning
1	Link not detected
0	Normal (default)

LOSS_SYNC Descrambler Loss of Synchronization Detect R/LT 13

LOSS_SYNC	
Bit	Meaning
1	Descrambler has lost sync
0	Normal (default)

CWRD Codeword Error R/LT 12

CWRD	
CWRD Bit	Meaning
1	Invalid 4B5B code detected on receive data
0	Normal (default)

SSD Start of Stream Error R/LT 11

SSD	
SSD Bit	Meaning
1	No Start of Stream Delimiter detected on receive data
0	Normal (default)

ESD End of Stream Error R/LT 10

ESD Bit	Meaning
1	No End of Stream Delimiter detected on receive data
0	Normal (default)

RPOL Reversed Polarity Detect R/LT 9

RPOL Bit	Meaning
1	Reversed Polarity detect
0	Normal (default)

JAB Jabber Detect R/LT 8

JAB Bit	Meaning
1	Jabber detected
0	Normal (default)

SPD_DET 100/10 Speed Detect R/LT 7

SPD_DET Bit	Meaning
1	Device in 100BASE-TX Mode (default)
0	Device in 10BASE-T Mode

DPLX_DET Duplex Detect R/LT 6

DPLX_DET Bit	Meaning
1	Device in Full Duplex mode
0	Device in Half Duplex mode (default)

R Reserved R [5:0]

These bits are reserved and must be remain at the default value of 0x0 for proper device operation.

3.3.10 Interrupt Mask Register (Register 19)

The default value for this register is 0xFFC0.

15	14	13	12	11	10	9	8
MASK_INT	MASK_LNK_FAIL	MASK_LOSS_SYNC	MASK_CWRD	MASK_SSD	MASK_ESD	MASK_RPOL	MASK_JAB
7	6	5	4	3	Reserved		
MASK_SPD_DET	MASK_DPLX_DET	FXLVL1	FXLVL0				

MASK_INT R/W 15

Interrupt Mask - Interrupt Detect

MASK_INT Bit	Meaning
1	Mask interrupt when INT bit = 1 in register 18 (default)
0	No interrupt mask

MASK_LNK_FAIL **R/W 14**

Interrupt Mask - Link Fail Detect

MASK_LNK_FAIL

Bit	Meaning
1	Mask interrupt for LNK_FAIL bit in register 18 (default)
0	No mask

MASK_LOSS_SYNC **R/W 13**

Interrupt Mask - Descrambler Loss of Sync Detect

MASK_LOSS_SYNC

Bit	Meaning
1	Mask interrupt for LOSS_SYNC bit in register 18 (default)
0	No mask

MASK_CWRD **R/W 12**

Interrupt Mask - Codeword Error

MASK_CWRD

Bit	Meaning
1	Mask Interrupt for CWRD bit in register 18 (default)
0	No mask

MASK_SSD **Interrupt Mask - Start of Stream Error** **R/W 11**

MASK_SSD

Bit	Meaning
1	Mask Interrupt for SSD bit in register 18 (default)
0	No mask

MASK_ESD **Interrupt Mask - End of Stream Error** **R/W 10**

MASK_ESD

Bit	Meaning
1	Mask Interrupt For ESD bit in register 18 (default)
0	No mask

MASK_RPOL **R/W 9**

Interrupt Mask - Reverse Polarity Detect

MASK_RPOL

Bit	Meaning
1	Mask interrupt for RPOL bit in register 18 (default)
0	No mask

MASK_JAB **R/W 8**

Interrupt Mask - Jabber Detect

MASK_JAB

Bit	Meaning
1	Mask interrupt for JAB bit in register 18 (default)
0	No mask

MASK_SPD_DET **R/W 7**

Interrupt Mask - 10/100 Speed Detect

MASK_SPD_DET

Bit	Meaning
1	Mask Interrupt for SPD_DET bit in register 18 (default)
0	No mask

MASK_DPLX_DET **R/W 6**

Interrupt Mask - 10/100 Duplex Detect

MASK_DPLX_DET

Bit	Meaning
1	Mask Interrupt for DPLX_DET bit in register 18 (default)
0	No mask

FXLVL[1:0] Fiber Transmit Level Adjust **R/W [5:4]**

FXLVL[1:0]

Bits	Adjustment
0b11	1.30
0b10	1.15
0b01	0.85
0b00 (default)	1.00

R **Reserved** **R/W [3:0]**

These bits are reserved and must be remain at the default value of 0 for proper device operation

3.3.11 Reserved Register (Register 20)

The default value for this register is 0x0000.

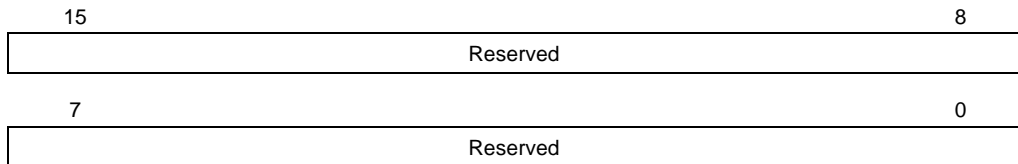

R **Reserved** **R/W [15:0]**

These bits are reserved and must be remain at the default value of 0 for proper device operation.

Chapter 4

Management Interface

This chapter describes the Management Interface, over which the internal device registers are accessed. It contains the following sections:

- Section 4.1, “Signal Description”
- Section 4.2, “General Operation”
- Section 4.3, “Multiple Register Access”
- Section 4.4, “Frame Structure”
- Section 4.5, “Register Structure”
- Section 4.6, “Interrupts”

The Management Interface, referred to as the MI serial port, is an eight-pin bidirectional link through which the internal device registers are accessed. The internal register bits control the configuration and capabilities of the device, and reflect device status.

The MI serial port provides access to 11 internal registers and meets all IEEE 802.3 specifications for the Management Interface.

4.1 SIGNAL DESCRIPTION

The MI serial port has eight pins:

- MDC: serial shift clock input pin
- MDIO: bidirectional data pin
- MDINTn: interrupt pin
- MDA[4:0]n: physical address pins

The MDA[4:0]n pins configure the device for a particular address, from 0b0000 to 0b1111, such that 16 devices can exist in the same address domain, and each be addressed separately over the MI serial port. When an MI read or write cycle occurs, the device compares the internally inverted and latched state of the MDA[4:0]n pins to the PHYAD[4:0] address bits of the MI frame. If the states compare, the device knows it is being addressed.

The MDA[4:0]n inputs share the same pins as the MDINTn and PLED[3:0]n outputs, respectively. At powerup or reset, the PLED[3:0]n and MDINTn output drivers are 3-stated for an interval called the power-on reset time. During the power-on reset interval, the value on these pins is latched into the device, inverted, and used as the MI serial port physical device addresses.

4.2 GENERAL OPERATION

The MI serial port is idle when at least 32 continuous ones are detected on the bi-directional MDIO data pin and remains idle as long as continuous ones are detected. During idle, the MDIO output driver is in the high-impedance state. When the MI serial port is in the idle state, a 0b01 pattern on the MDIO pin initiates a serial shift cycle. Control and address bits are clocked into MDIO on the next 14 rising edges of MDC (the MDIO output driver is still in a high-impedance state). If the multiple register access mode is not enabled, data is either shifted in or out on MDIO on the next 16 rising edges of MDC, depending on whether a write or read cycle was selected with the READ and WRITE operation bits. After the 32 MDC cycles have been completed:

- One complete register has been read or written
- The serial shift process is halted
- Data is latched into the device
- The MDIO output driver goes into a high-impedance state.

Another serial shift cycle cannot be initiated until the idle condition is detected again (at least 32 continuous ones). Figure 4.1 shows a timing diagram for a MI serial port cycle.

Figure 4.1 MI Serial Port Frame Timing Diagram

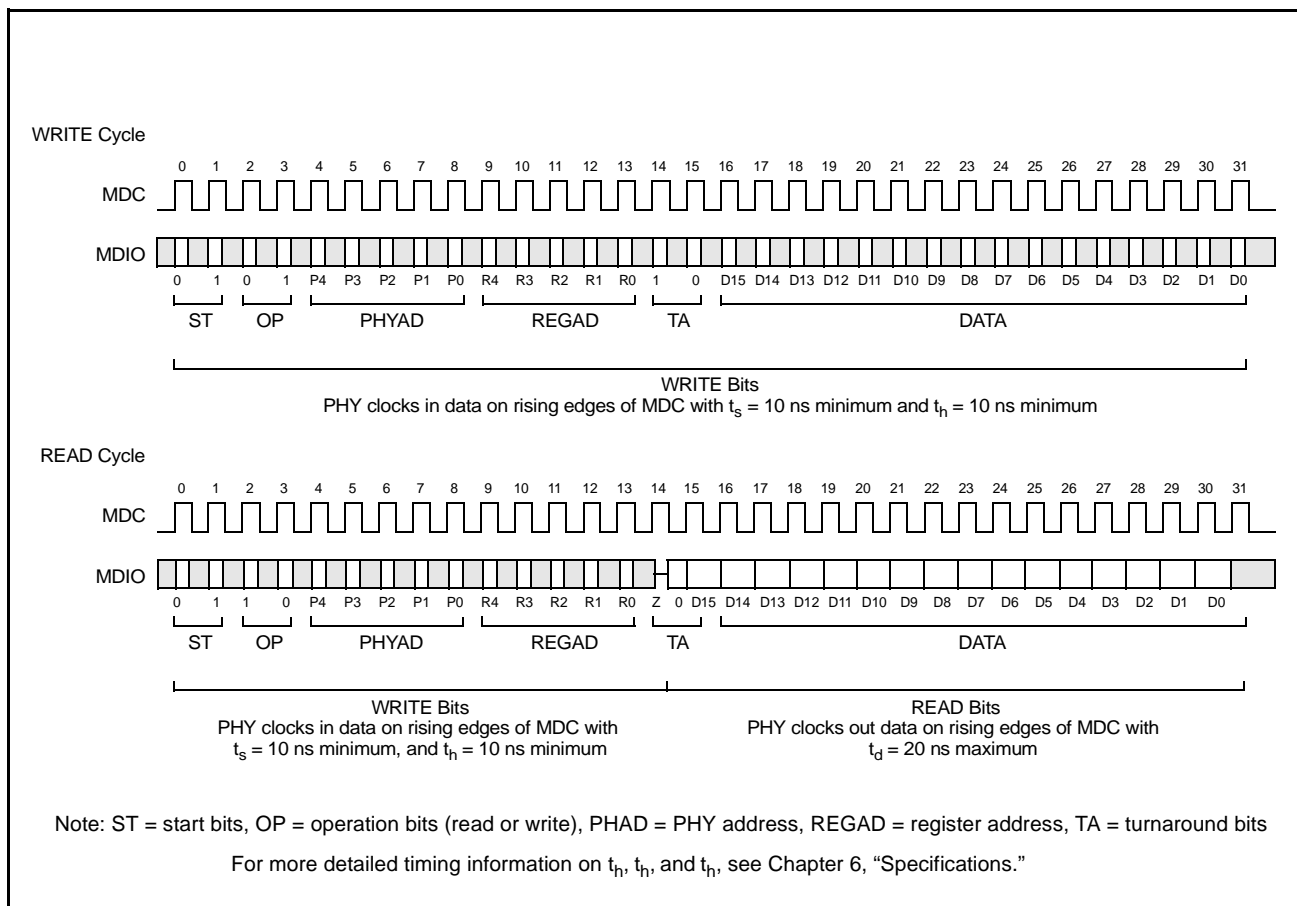

4.3 MULTIPLE REGISTER ACCESS

Multiple registers can be accessed on a single MI serial port access cycle with the multiple register access feature. Setting the Multiple Register Access Enable (MREG)

bit in the MI serial port Configuration 2 Register enables the multiple register access feature.

When the PHYAD[4:0] bits in the MI frame match MDA[4:0] pins on the device and the REGAD[4:0] bits are set to 0b11111 during the first 16 clock cycles, all 11 registers are accessed on the 176 rising edges of MDC (11 registers x 16 bits per register) that occur after the first 16 MDC clock cycles of the MI serial port access cycle. There is no actual register residing at 0b1111, but this condition triggers the access of multiple registers.

The registers (0, 1, 2, 3, 4, 5, 16, 17, 18, 19, and 20) are accessed in numerical order from 0 to 20. After all 192 MDC clocks (16 + 176) have been completed:

- All the registers have been read or written
- The serial shift process is halted
- Data is latched into the device
- MDIO goes into a high-impedance state.

Another serial shift cycle cannot be initiated until the idle condition (at least 32 continuous ones) is detected.

4.4 FRAME STRUCTURE

The structure of the serial port frame is shown in Figure 4.2 and a timing diagram is shown in Figure 4.1. Each serial port access cycle consists of 32 bits, exclusive of idle. The first 16 bits of the serial port cycle are always write bits and are used for control and addressing. The last 16 bits are data that is written to or read from a data register.

The first two bits in Figure 4.2 and Figure 4.1 are start bits (ST[1:0]) and must be written as a 0b01 for the serial port cycle to continue. The next two bits are the READ and WRITE bits, which determine whether a registers is being read or written. The next five bits are the PHY device address bits (PHYAD[4:0]), and they must match the inverted values latched from the MDA[4:0]n pins during the power on reset time for access to continue.

The next five bits are register address select (REGAD[4:0]) bits, which select one of the 11 registers for access. The next two bits are turnaround (TA) bits, which are not actual register bits but provide the device extra time to switch the MDIO pin function from a write pin to a read pin, if necessary. The final 16 bits of the MI serial port cycle are written to or read from the specific data register that the register address bits (REGAD[4:0]) designate. Figure 4.2 shows the MI frame structure.

Figure 4.2 MI Serial Frame Structure

IDLE	ST[1:0]	READ	WRITE	PHYAD[4:0]	REGAD[4:0]	TA[1:0]	D[15:0]
IDLE	Idle Pattern					W	
	These bits are an idle pattern. The device does not initiate an MI cycle until it detects an idle pattern of at least 32 consecutive ones.						
ST[1:0]	Start Bits					W	
	When ST[1:0] = 01, a MI serial port access cycle starts.						
READ	Read Select					W	
	When the READ bit is 1, it designates a read cycle.						
WRITE	Write Select					W	
	When the WRITE bit is 1, it designates a write cycle.						
PHYAD[4:0]	Physical Device Address					W	
	When the PHYAD[4:0] bits match the inverted latched value of the MDA[3:0]n pins, the device's MI serial port is selected for operation.						
REGAD[4:0]	Register Address					W	
	The REGAD[4:0] bits determine the specific register to access.						
TA[1:0]	Turnaround Time					R/W	
	These bits provide some turnaround time for MDIO to allow it to switch to a write input or read output, as needed. When READ = 1, TA[1:0] = 0bZ0; when WRITE = 1, TA[1:0] = 0b10.						
D[15:0]	Data					R or W	
	These 16 bits contain data to or from one of the registers selected with the register address bits REGAD[4:0].						

4.5 REGISTER STRUCTURE

The device has 11 16-bit registers. A map of the registers is shown in Section 3.2, "MI Serial Port Register Summary". See Chapter 3, Registers for a complete description of each register.

The 11 registers consist of six registers that are defined by IEEE 802.3 specifications (registers 0 to 5) and five registers that are unique to the device (registers 16 through 20). Table 4.1 gives a summary of the functions of each register.

Table 4.1 MI Serial Port Register Summary

Register	Name	Description
0	Control Register	Stores various configuration bits
1	Status Register	Contains device capability and status output bits
2	PHY ID 1	Contain an identification code unique to the device
3	PHY ID 2	
4	AutoNegotiation Advertisement	Contains bits that control the operation of the AutoNegotiation algorithm
5	AutoNegotiation Remote End Capability	Contains bits that reflect the AutoNegotiation capabilities of the link partner's PHY
16	Configuration 1	Stores various configuration bits
17	Configuration 2	Stores various configuration bits
18	Channel Status Output	Contains status
19	Mask	Contains interrupt mask bits
20	Reserved	Reserved for factory use

4.6 INTERRUPTS

The device has hardware and software interrupt capability. Certain output status bits (also referred to as interrupt bits) in the serial port trigger interrupts.

The R/LT interrupt bits (bits [14:6]) in the Channel Status Output Register cause an interrupt when they transition provided they are not masked with the mask bits in the Interrupt Mask register. These interrupt bits stay latched until read. When all interrupt bits are read, the interrupt indication is removed and the interrupt bits that caused the interrupt are updated to their current value.

Setting the appropriate mask register bits in the Interrupt Mask Register individually can mask and remove an interrupt bit as a source of interrupt.

Interrupt indication is done in three ways:

- MDINTn pin: The MDINTn pin is an active-LOW interrupt output indication.
- INT bit: The INT bit in the Status Output Register, when set, indicates that one or more interrupt bits have changed since the register was last read.
- Interrupt pulse on MDIO: When the Interrupt Scheme Select bit (INT_MDIO) is set in the Configuration 2 register, an interrupt is indicated with a low-going pulse on MDIO when MDC is high and the serial port is in the idle state, as shown in the timing diagram in Figure 4.3. After the interrupt pulse, MDIO goes back to the high-impedance state. If the interrupt occurs while the serial port is being accessed, the MDIO interrupt pulse is delayed until one clock bit after the serial port access cycle has ended, as shown in Figure 4.3

Figure 4.3 MDIO Interrupt Pulse

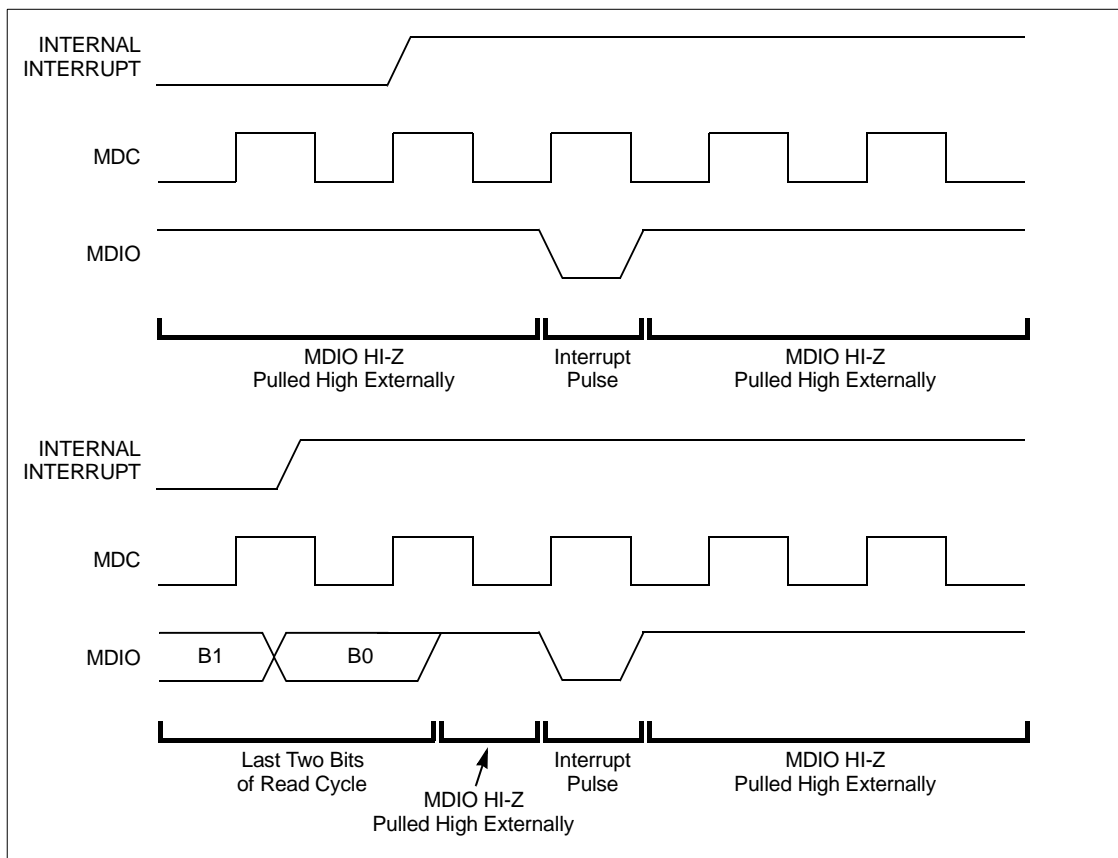

Chapter 5

Specifications

This chapter contains the complete electrical, timing, and mechanical specifications

for the device. It contains the following sections:

- Section 5.1, “Absolute Maximum Ratings”
- Section 5.2, “Electrical Characteristics”
- Section 5.2.2, “FX Characteristics, Transmit”
- Section 5.3, “AC Electrical Characteristics”
- Section 5.4, “LED Driver Timing Characteristics”
- Section 5.5, “Pinouts and Package Drawings”
- Section 5.6, “Mechanical Drawing”

5.1 ABSOLUTE MAXIMUM RATINGS

Table 5.1 shows the device absolute maximum ratings. These are limits which, if exceeded, could cause permanent damage to the device or affect device reliability. All voltages are specified with respect to GND unless otherwise specified.

Table 5.1 Absolute Maximum Ratings

Parameter	Range	Units
V _{DD} Supply Voltage	-0.3V to +4.0V	V
All Inputs and Outputs	-0.3V to 5.5V	V
Package Power Dissipation	2.0 @ 70°C	W
Storage Temperature	-65 to +150	°C
Temperature Under Bias	-10 to +80 °C	°C
Lead Temperature (soldering, 10 sec)	260	°C
Body Temperature (soldering, 30 sec)	220	°C

5.2 ELECTRICAL CHARACTERISTICS

Table 5.2 lists the device DC electrical characteristics. Unless otherwise noted, all test conditions are as follows:

$T_A = 0$ to $+70$ °C
 $V_{DD} = 3.3$ V $\pm 5\%$
 Clock = 25 MHz $+ 0.01\%$
 $R_{EXT} = 10$ K Ω $\pm 1\%$, no load

Table 5.2 DC Characteristics

Sym	Parameter	Limit			Unit	Conditions
		Min	Typ	Max		
VIL	Input Low Voltage			0.8	Volt	All except OSCIN, MDA[4:0]n SD/FXDISn, SD_THR
				$V_{DD} - 1.0$	Volt	MDA[4:0]n
				1.5	Volt	OSCIN
				0.45	Volt	SD/FXDISn (for FX disable), SD_THR (for 3.3V/5V select)
VIH	Input High Voltage	2			Volt	All except OSCIN, MDAn[4:0], SD/FXDISn, SD_THR
		$V_{DD} - 0.5$			Volt	MDA[4:0]n
		2.3			Volt	OSCIN
		0.85			Volt	SD/FXDISn (for FX disable), SD_THR (for 3.3 V/5 V select)
IIL	Input Low Current			-1	uA	VIN = GND All except OSCIN, MDA[4:0]n, RESETn
		-4		-25	uA	VIN = GND. MDA[4:0]n
		-12		-120	uA	VIN = GND. RESETn
				-150	uA	VIN = GND. OSCIN
IIH	Input High Current			1	uA	VIN = V_{DD} . All except OSCIN, RPTR
		12		120	uA	VIN = V_{DD} . RPTR
				150	uA	VIN = V_{DD} . OSCIN
VOL	Output Low Voltage			0.4	Volt	IOL = -4 mA. All except PLED[5:0]n
				1	Volt	IOL = -10 mA. PLED[5:0]n
VOH	Output High Voltage	$V_{DD} - 1.0$			Volt	IOH = 4 mA. All Except PLED[5:0]n, MDINTn
		2.4			Volt	IOH = 4 uA. PLED[5:2]n, MDINTn
		$V_{DD} - 1.0$			Volt	IOH = 10 mA. PLED[1:0]n
CIN	Input Capacitance		5		pF	

Table 5.2 DC Characteristics (Cont.)

Sym	Parameter	Limit			Unit	Conditions
		Min	Typ	Max		
I _{DD}	V _{DD} Supply Current			120	mA	Transmitting, 100 Mb/s
				140	mA	Transmitting, 10 Mb/s
I _{GND}	GND Supply Current			190	mA	Transmitting, 100 Mb/s ¹
				220	mA	Transmitting, 10 Mb/s ¹
IPDN	Powerdown Supply Current			200	μA	Powerdown, either I _{DD} or I _{GND}

1. I_{GND} includes current flowing into GND from the external resistors and transformer on TPO/FXO as shown in ?Application Note?

5.2.1 Twisted-Pair DC Characteristics

Unless otherwise noted, all test conditions for TP transmit and receive operations are as follows:

T_A = 0 to + 70 °C

V_{DD} = 3.3 V ± 5%

Clock = 25 MHz ±0.01%

R_{EXT} = 10 KΩ ±1%, no load

TPO+/- loading is as shown in ?Application Note? or equivalent

62.5/10 MHz Square Wave on TP+/- inputs in 100/10 Mb/s modes

Table 5.3 shows the twisted-pair characteristics for transmit operation.

Table 5.3 Twisted Pair Characteristics (Transmit)

Sym	Parameter	Limit			Unit	Conditions
		Min	Typ	Max		
TOV	TP Differential Output Voltage	0.950	1.000	1.050	V pk	100 Mb/s, UTP Mode, 100 Ohm Load
		1.165	1.225	1.285	V pk	100 Mb/s, STP Mode, 150 Ohm Load
		2.2	2.5	2.8	V pk	10 Mb/s, UTP Mode, 100 Ohm Load
		2.694	3.062	3.429	V pk	10 Mb/s, STP Mode, 150 Ohm Load
TOVS	TP Differential Output Voltage Symmetry	98		102	%	100 Mb/s, ratio of positive and negative amplitude peaks on TPO±
TORF	TP Differential Output Rise and Fall Time	3.0		5.0	nS	100 Mb/s TRF[1:0] = 0b10
TORFS	TP Differential Output Rise and Fall Time Symmetry			±0.5	nS	100 Mb/s, difference between rise and fall times on TPO±

Table 5.3 Twisted Pair Characteristics (Transmit (Cont.))

Sym	Parameter	Limit			Unit	Conditions
		Min	Typ	Max		
TODC	TP Differential Output Duty Cycle Distortion			± 0.25	nS	100 Mbits/s, output data = 0101... NRZ pattern unscrambled, measure at 50% Points
TOJ	TP Differential Output Jitter			± 1.4	nS	100 Mbits/s, output data = scrambled /H/
TOO	TP Differential Output Overshoot			5.0	%	100 Mbits/s
TOVT	TP Differential Output Voltage Template	See Figure 1.4				10 Mbits/s
TSOI	TP Differential Output SOI Voltage Template	See Figure 1.8				10 Mbits/s
TLPT	TP Differential Output Link Pulse Voltage Template	See Figure 1.6				10 Mbits/s, NLP and FLP
TOIV	TP Differential Output Idle Voltage			± 50	mV	10 Mbits/s. Measured on secondary side of transformer in ?Apmote?.
TOIA	TP Output Current	38	40	42	mApk	100 Mbits/s, UTP with TLVL[3:0] = 0b1000
		31.06	32.66	34.26	mApk	100 Mbits/s, STP with TLVL[3:0] = 0b1000
		88	100	112	mApk	10 Mbits/s, UTP with TLVL[3:0] = 0b1000
		71.86	81.64	91.44	mApk	10 Mbits/s, STP with TLVL[3:0] = 0b1000
TOIR	TP Output Current Adjustment Range	0.80		1.2		VDD = 3.3 V, adjustable with REXT, relative to TOIA with REXT = 10K
		0.86		1.16		VDD = 3.3 V, Adjustable with TLVL[3:0] See ?Application Note?, relative to value at TLVL[3:0] = 0b1000
TORA	TP Output Current TLVL Step Accuracy			± 50	%	Relative to ideal values in Figure 1.6. Table 1.6 values relative to output with TLVL[3:0] = 0b1000.
TOR	TP Output Resistance		10 K		Ohm	
TOC	TP Output Capacitance		15		pF	

Table 5.4 shows the twisted-pair characteristics for receive operation.

Table 5.4 Twisted Pair Characteristics (Receive)

Sym	Parameter	Limit			Unit	Conditions
		Min	Typ	Max		
RST	TP Input Squelch Threshold	166		500	mVpk	100 Mbits/s, RLVL0 = 0
		310		540	mVpk	10 Mbits/s, RLVL0 = 0
		60		200	mVpk	100 Mbits/s, RLVL0 = 1
		186		324	mVpk	10 Mbits/s, RLVL0 = 1
RUT	TP Input Unsquelch Threshold	100		300	mVpk	100 Mbits/s, RLVL0 = 0
		186		324	mVpk	10 Mbits/s, RLVL0 = 0
		20		90	mVpk	100 Mbits/s, RLVL0 = 1
		112		194	mVpk	10 Mbits/s, RLVL0 = 1
ROCV	TP Input Open Circuit Voltage		$VDD - 2.4 \pm 0.2$		Volt	Voltage on either TPI+ or TPI- with respect to GND.
RCMR	TP Input Common Mode Voltage Range		$ROCV \pm 0.25$		Volt	Voltage on TPI± with respect to GND.
RDR	TP Input Differential Voltage Range			VDD	Volt	
RIR	TP Input Resistance	5K			Ohm	
RIC	TP Input Capacitance		10		pF	

5.2.2 FX Characteristics, Transmit

Unless otherwise noted, all test conditions for FX transmit and receive operations are as follows:

- TA = 0 to +70 °C
- VDD=3.3 V ± 5%
- 25 MHz ± 0.01%
- REXT=10 K ± 1%, no load
- FXO± Loading as shown in ?Apnote? or Equivalent
- 125 MHz Square Wave on FXI+/- and SD Inputs

Table 5.5 shows the FX characteristics for transmit operation.

Table 5.5 FX Characteristics, Transmit

Sym	Parameter	Limit			Unit	Conditions
		Min	Typ	Max		
FOVH	FXO± Output Voltage, High	VDD - 1.020		VDD - 0.880	V	Single-ended, measure FXO± relative to GND
FOVL	FXO± Output Voltage, Low	VDD - 1.810		VDD - 1.620	V	Single-ended, measure FXO± relative to GND
FOIA	FXO± Output Current	12		20	mA pk	
FOIR	FXO± Output Current Adjustment Range	0.85		1.15		VDD = 3.3 V, adjustable with REXT, relative to FOIA with REXT = 10 K
		0.85		1.30		VDD = 3.3 V, adjustable With FLVL[1:0], relative To value at FLVL[1:0] = 0b10
FORA	FXO± Output Current TLVL Step Accuracy			±0.50	%	Relative to ideal values In Table 1.9
FORF	FXO± Differential Output Rise and Fall Time			1.3	ns	
FORFS	FXO± Differential Output and Fall Time Symmetry			±0.5	ns	Difference between rise nd fall times on FXO+
FODC	FXO± Differential Output Duty Cycle Distortion			±0.25	ns	Output Data = 0101... pattern measure at 50% points
FOJ	FXO± Differential Output Jitter			±1.3	ns	Output data = /H/
FOR	FXO± Output Resistance		10 K		Ohm	
FOC	FXO± Output Capacitance		10		pF	

Table 5.6 shows the FX characteristics for receive operation.

Table 5.6 FX Characteristics, Receive

Sym	Parameter	Limit			Unit	Conditions
		Min	Typ	Max		
FDIV	FXI± Differential Input Voltage	0.150			V pk	
FCMR	FXI± Input Common Mode Voltage Range	1.35		VDD - 0.80	V	Voltage on Either FXI+ or FXI- with respect to GND
FSDIH	SD/FXDISn Input High Voltage	VTRIP - 50mV			V	When SD/FXDISn is used as a Signal Detect input, not as the FX disable input. VTRIP = (VDD -1.3V) ± 10%.
FSDIL	SD/FXDISn Input Low Voltage	VTRIP - 50 mV			V	When SD/FXDISn is used as a Signal Detect input, not as the FX disable input. VTRIP = (VDD - 1.3V) ± 10%
FSDTHR	SD_THR Input Voltage	VDD - 1.3V - 2%	VDD - 1.3V	VDD - 1.3V + 2%	V	When interfacing to 5 V fiber transceivers. When interfacing to 3.3 V fiber transceivers, SD_THR is tied to GND.
FIR	FXI±, SD/FXDISn Input Resistance	5K			ohm	
FIC	FX± SD/FXDISn Input Capacitance		10		pF	

5.3 AC ELECTRICAL CHARACTERISTICS

Unless otherwise noted, all test conditions are as shown in Table 5.7.

Table 5.7 Test Conditions

Test Condition	Parameter	Value
Temperature	TA	0 to +70°C
Voltage	V _{DD}	3.3V ± 5%
Clock Frequency		25 MHz ± 0.01%
External Resistor	REXT	10K ± 1%, no load
Input Conditions (all inputs)	tr, tf	≤ 10 ns, 20-80% points
Output Loading		
TPO±	Same as ?A _{pnote} ? or equivalent	10 pF
Open-drain outputs		1K pullup, 50 pF
All other digital outputs		25 pF
Measurement Points		
TPO±, TPI±		0.0 V during data, ± 0.3 V at start/end of packet
All other inputs and outputs		1.4 V

5.3.1 25 MHz Input/Output Clock Timing Characteristics

Table 5.8 25 MHz Input/Output Clock¹

Sym	Parameter	Limit			Unit	Conditions
		Min	Typ	Max		
t1	OSCIN Period	39.996	40	40.004	ns	Clock applied to OSCIN
t2	OSCIN High Time	16			ns	Clock applied to OSCIN
t3	OSCIN Low Time	16			ns	Clock applied to OSCIN
t4	OSCIN to TX_CLK Delay			10	ns	100 Mbits/s
				20	ns	10 Mbits/s

1. Refer to Figure 5.1 for Timing Diagram

Figure 5.1 25 MHz Output Timing

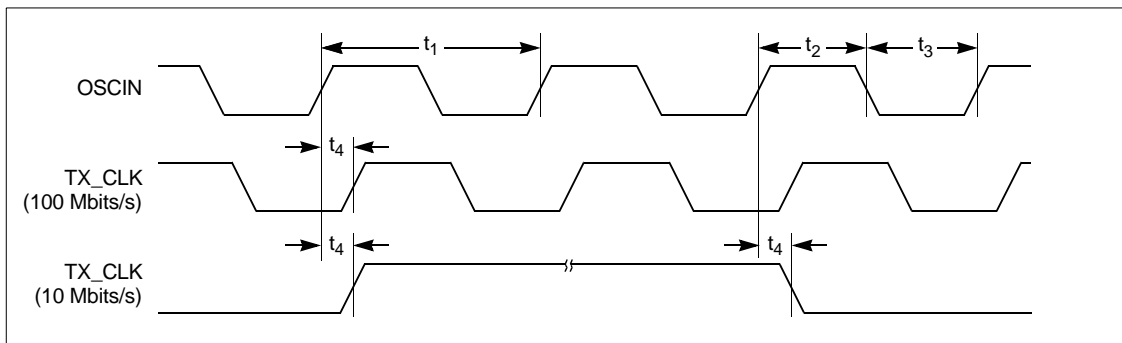

5.3.2 Transmit Timing Characteristics

Table 5.9 shows the Transmit AC timing parameters. See Figure 5.2 and Figure 5.3 for the 100 Mb/s and 10 Mb/s transmit timing diagrams.

Table 5.9 Transmit Timing

Sym	Parameter	Limit			Unit	Conditions
		Min	Typ	Max		
t11	TX_CLK Period	39.996	40	40.004	ns	100 Mb/s
		399.96	400	400.04	ns	10 Mb/s
t12	TX_CLK Low Time	16	20	24	ns	100 Mb/s
		160	200	240	ns	10 Mb/s
t13	TX_CLK High Time	16	20	24	ns	100 Mb/s
		160	200	240	ns	10 Mb/s
t14	TX_CLK Rise/Fall Time			10	ns	
t15	TX_EN Setup Time	15			ns	Note ¹
t16	TX_EN Hold Time	0			ns	
t17	CRS During Transmit Assert Time			40	ns	100 Mb/s
				400	ns	10 Mb/s
t18	CRS During Transmit Deassert Time			160	ns	100 Mb/s
				900	ns	10 Mb/s
t19	TXD Setup Time	15			ns	Note 1
t20	TXD Hold Time	0			ns	
t21	TX_ER Setup Time	15			ns	Note 1
t22	TX_ER Hold Time	0			ns	
t23	Transmit Propagation Delay	60		140	ns	100 Mb/s, MII
				140	ns	100 Mb/s, FBI
				600	ns	10 Mb/s
t24	Transmit Output Jitter			± 0.7	ns pk-pk	100 Mb/s
				± 5.5	ns pk-pk	10 Mb/s
t25	Transmit SOI Pulse Width To 0.3 V	250			ns	10 Mb/s
t26	Transmit SOI Pulse Width to 40 mV			4500	ns	10 Mb/s
t27	PLEDn Delay Time			25	ms	PLEDn programmed for activity
t28	PLEDn Pulse Width	80		105	ms	PLEDn programmed for activity

1. Setup time measured with 5 pF loading on TXC. Additional loading will create a delay on TXC rise time, which requires increased setup times.

Figure 5.2 Transmit Timing - 100 Mbits/s

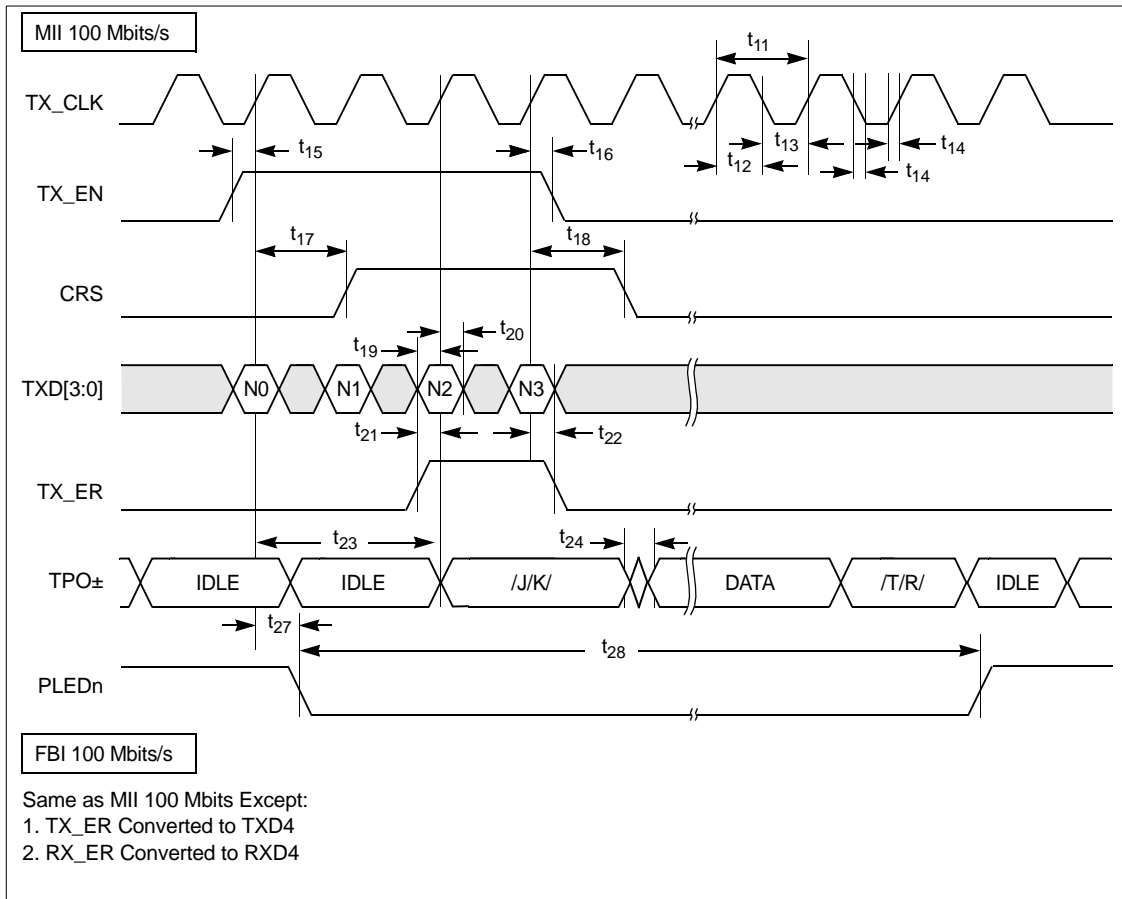
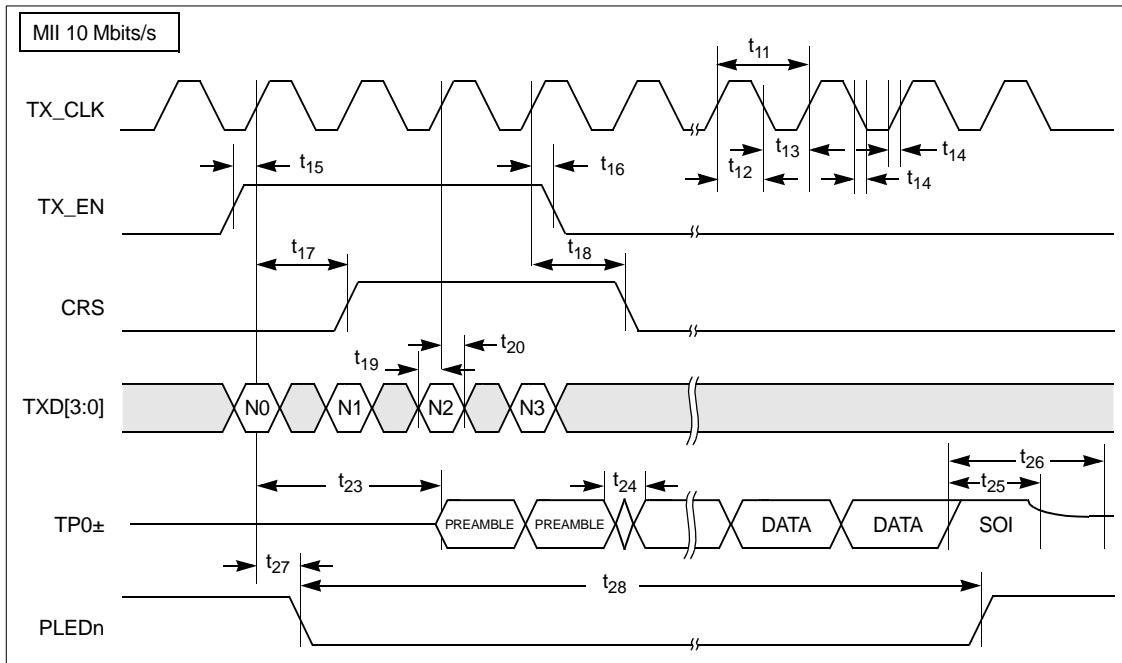

Figure 5.3 Transmit Timing - 10 Mbits/s



5.3.3 Receive Timing Characteristics

Table 5.10 shows the Receive AC timing parameters. See Figure 5.4 through Figure 5.8 for the receive timing diagrams.

Table 5.10 Receive Timing

Sym	Parameter	Limit			Unit	Conditions
		Min	Typ	Max		
t31	Start Of Packet To CRS Assert Delay			200	ns	100 Mbits/s, MII
				200	ns	100 Mbits/s, FBI
				700	ns	10 Mbits/s
t32	End Of Packet To CRS Deassert Delay	130		240	ns	100 Mbits/s, MII
				240	ns	100 Mbits/s, FBI
				600	ns	10 Mbits/s. relative to start of SOI pulse
t33	Start Of Packet To RX_DV Assert Delay			240	ns	100 Mbits/s
				3600	ns	10 Mbits/s
t34	End Of Packet To RX_DV Deassert Delay			280	ns	100 Mbits/s
				1000	ns	10 Mbits/s. relative to start of SOI pulse
t37	RX_CLK To RX_DV, RXD, RX_ER Delay	-8		8	ns	100 Mbits/s
		-80		80	ns	10 Mbits/s
t38	RX_CLK High Time	18	20	22	ns	100 Mbits/s
		180	200	600	ns	10 Mbits/s
t39	RX_CLK Low Time	18	20	22	ns	100 Mbits/s
		180	200	600	ns	10 Mbits/s
t40	SOI Pulse Minimum Width Required for Idle Detection	125		200	ns	10 Mbits/s measure TPI± from last zero cross to 0.3V point.

Figure 5.5 Receive Timing, End of Packet - 100 Mbits/s

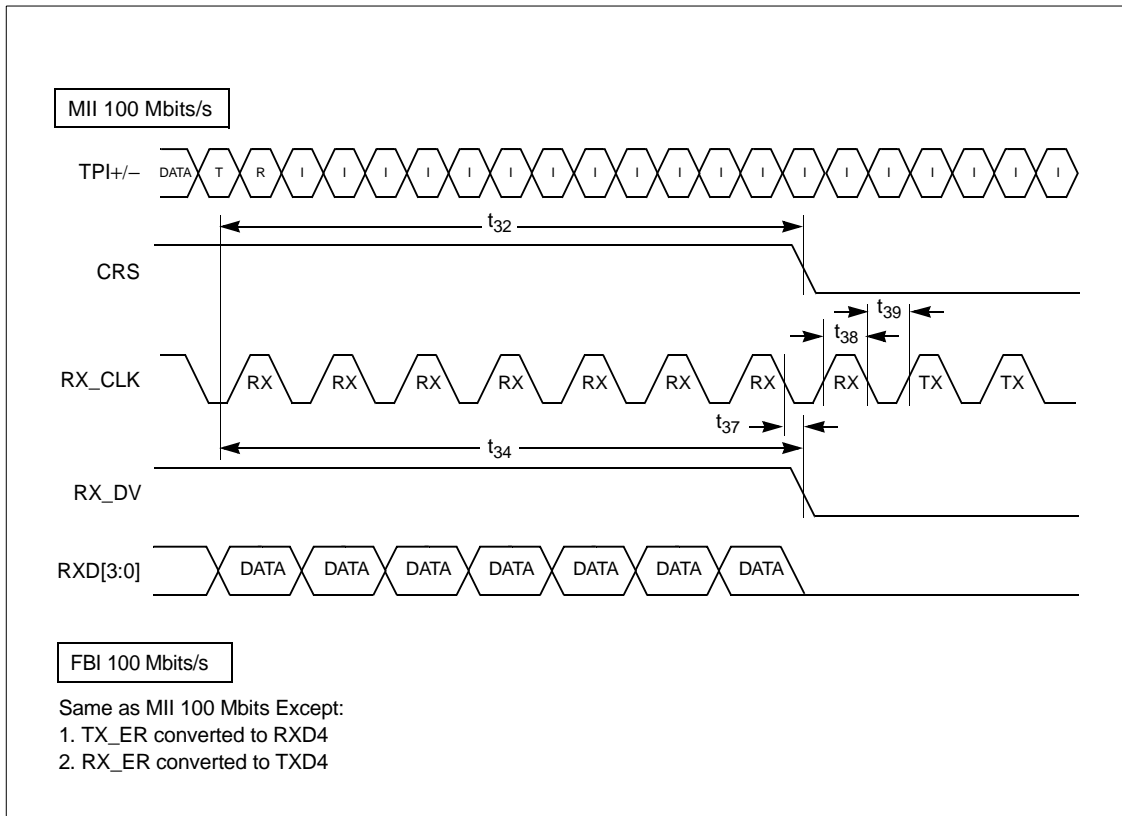

Figure 5.6 Receive Timing, Start of Packet - 10 Mbits/s

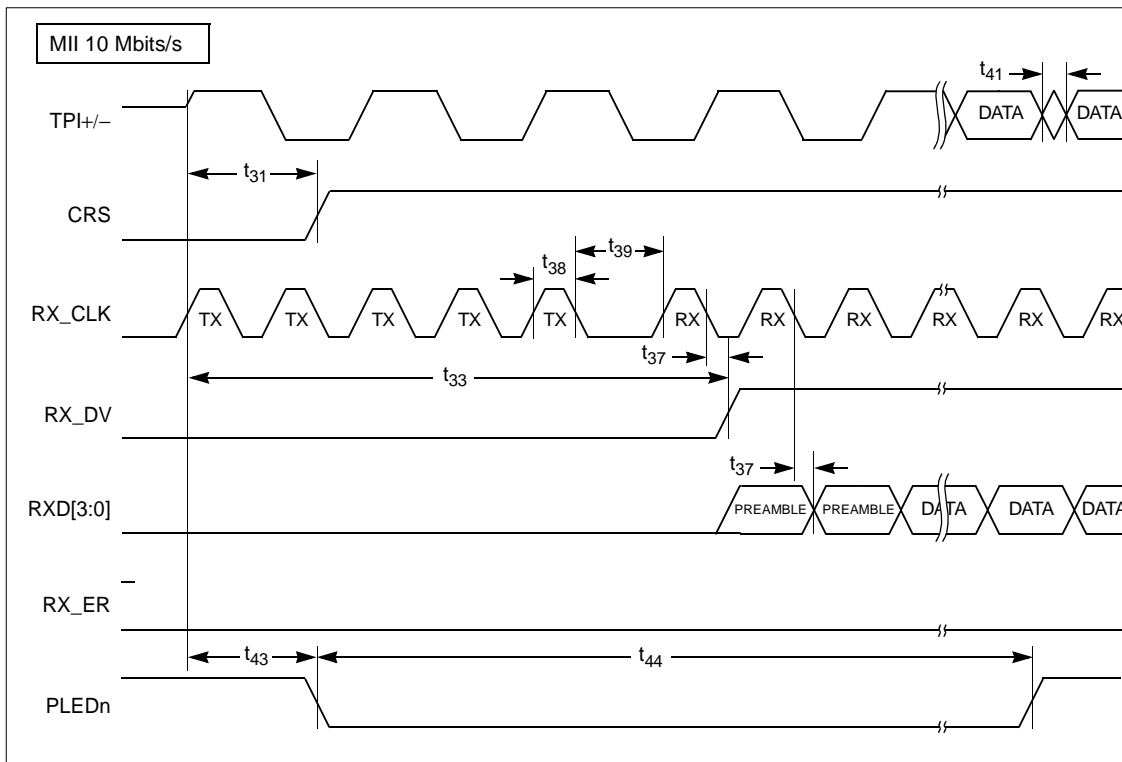

Figure 5.7 Receive Timing, End of Packet - 10 Mbits/s

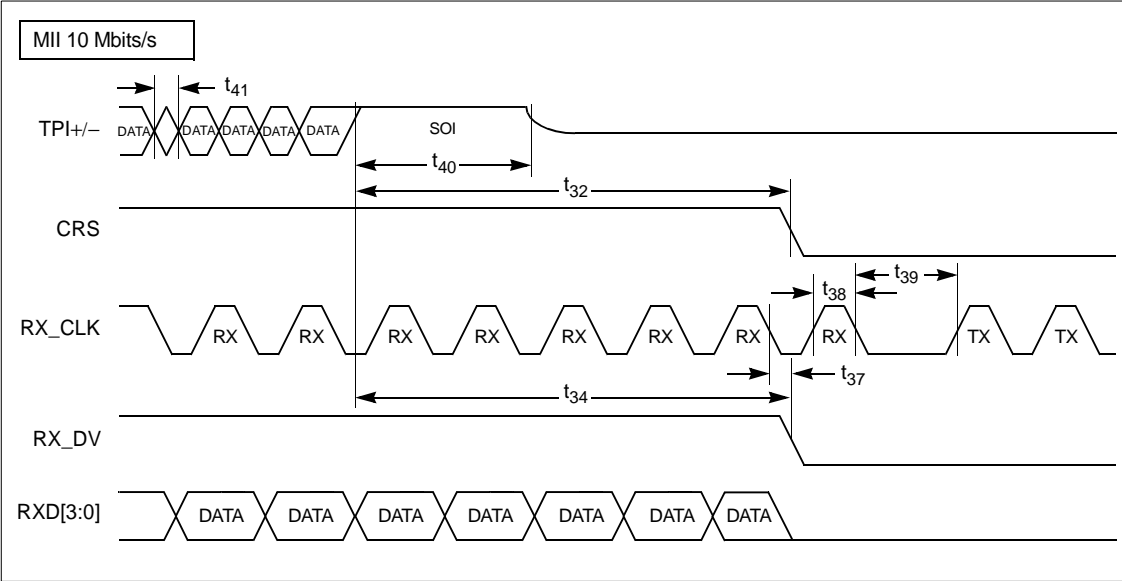
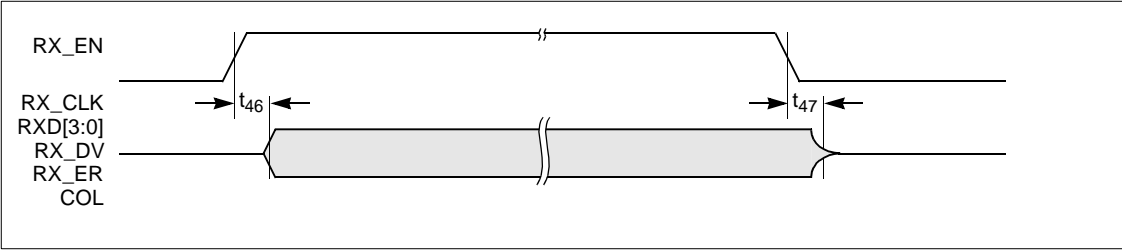

Figure 5.8 RX_EN Timing



5.3.4 Collision and JAM Timing Characteristics

Table 5.11 shows the Collision and JAM timing parameters. See Figure 5.9 through Figure 5.14 for the associated timing diagrams.

Table 5.11 Collision and Jam Timing

SYM	PARAMETER	LIMIT			UNIT	CONDITIONS
		MIN	TYP	MAX		
t51	Rcv Packet Start To COL Assert Time			200	ns	100 Mbits/s
				700	ns	10 Mbits/s
t52	Rcv Packet Stop To COL Deassert Time	130		240	ns	100 Mbits/s
				300	ns	10 Mbits/s
t53	Xmt Packet Start To COL Assert Time			200	ns	100 Mbits/s
				700	ns	10 Mbits/s
t54	Xmt Packet Stop To COL Deassert Time			240	ns	100 Mbits/s
				300	ns	10 Mbits/s
t55	PLEDn Delay Time			25	ms	PLEDn programmed for collision
t56	PLEDn Pulse Width	80		105	ms	PLEDn programmed for collision
t57	Collision Test Assert Time			5120	ns	
t58	Collision Test Deassert Time			40	ns	
t59	CRS Assert To Transmit JAM Packet Start During JAM			300	ns	100 Mbits/s
				800	ns	10 Mbits/s
t60 ¹	COL Rise And Fall Time			10	ns	

1. Timing not shown

Figure 5.9 Collision Timing, Receive 100 Mbits/s

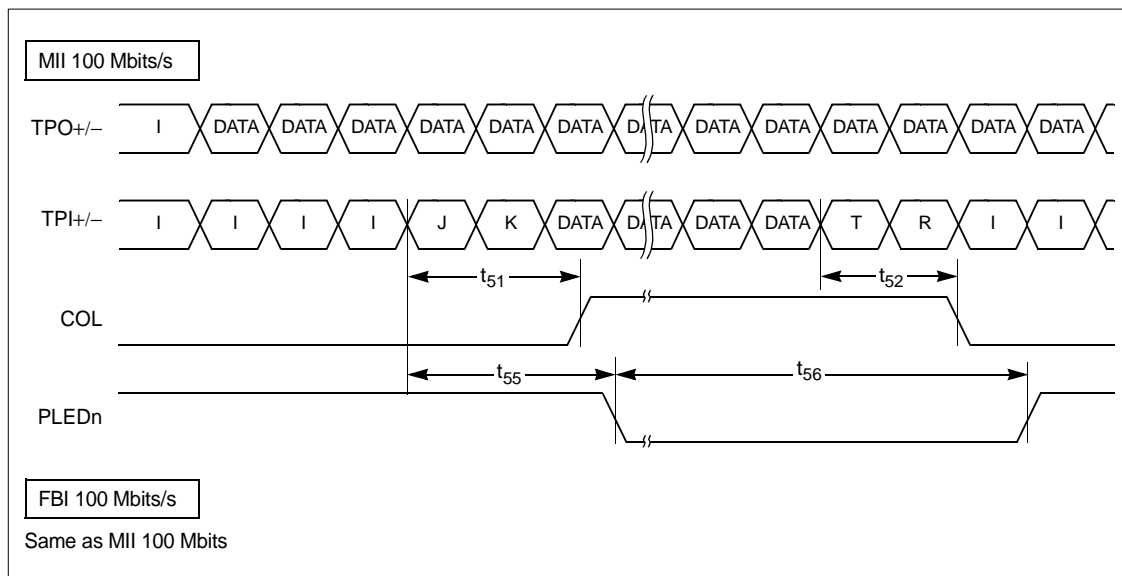

Figure 5.10 Collision Timing, Receive 10 Mbits/s

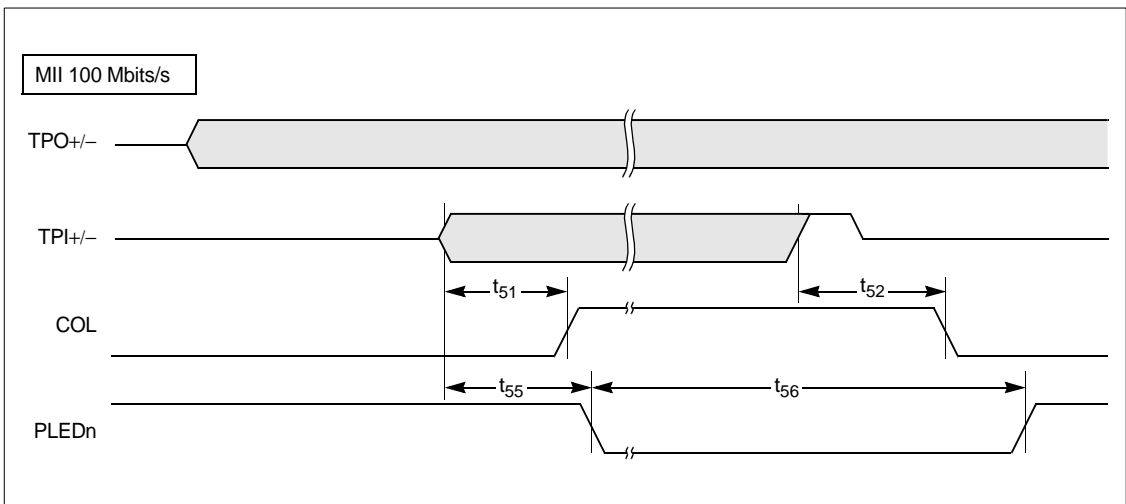

Figure 5.11 Collision Timing, Transmit - 100 Mbits/s

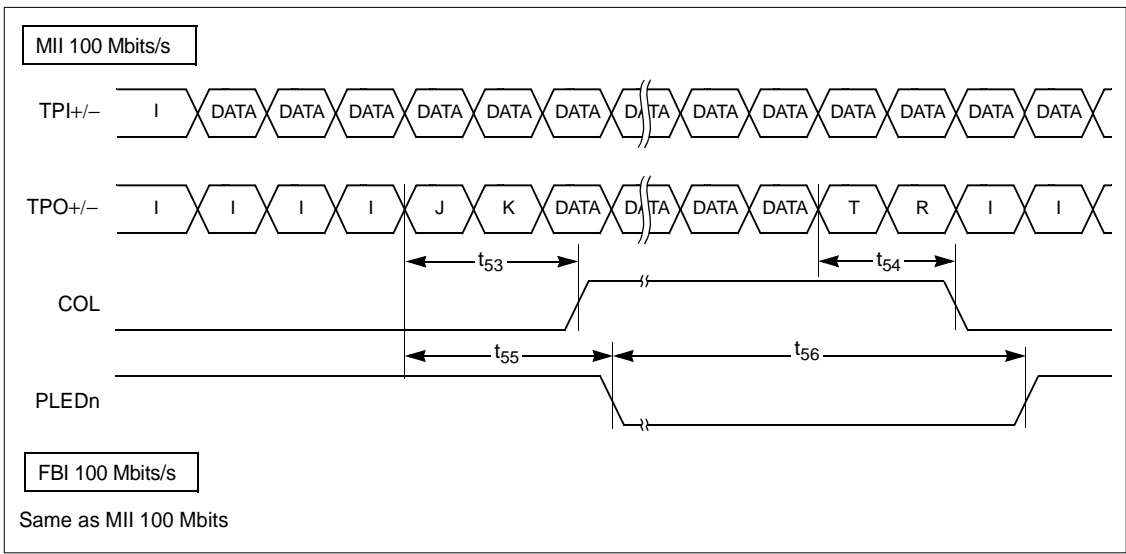

Figure 5.12 Collision Timing, Transmit - 10 Mbits/s

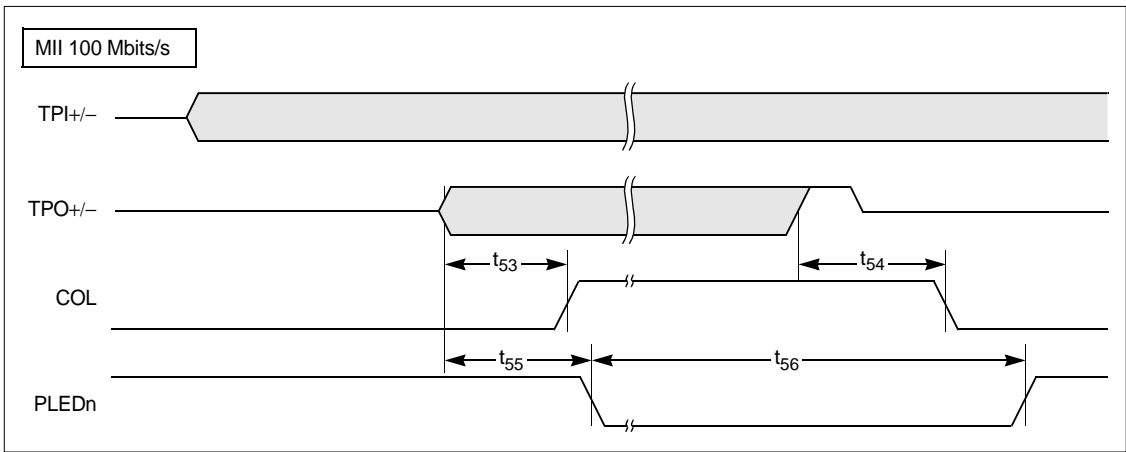

Figure 5.13 Collision Test Timing

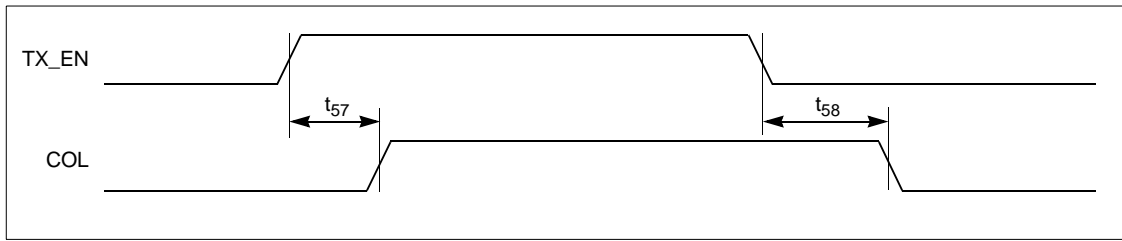
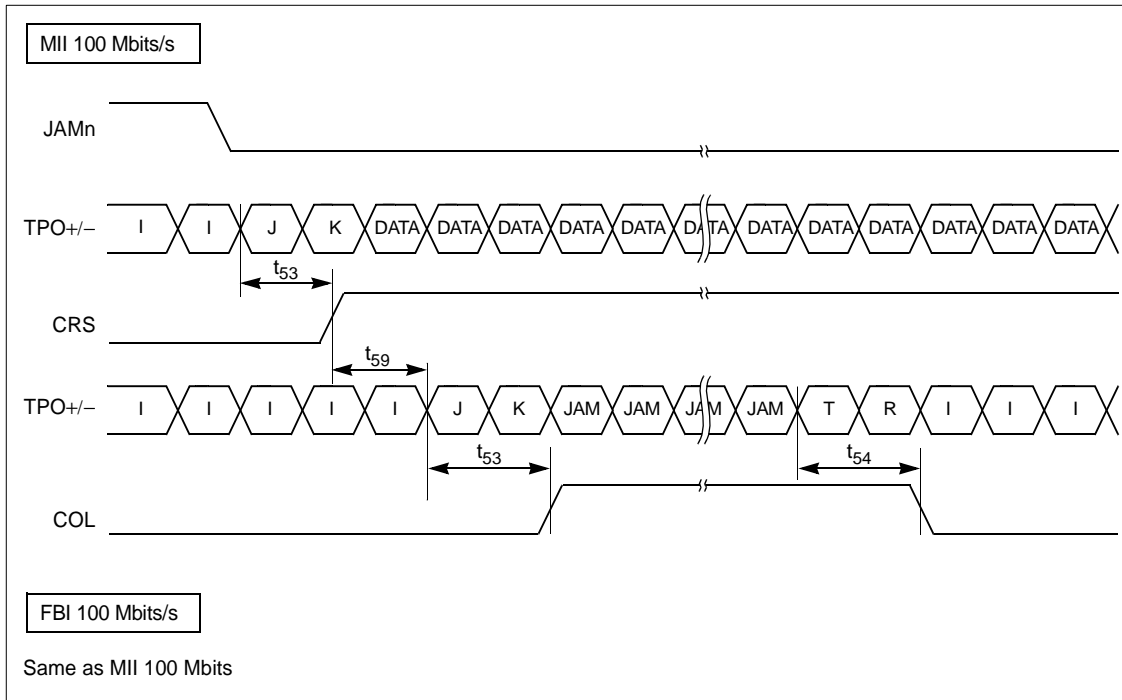

Figure 5.14 JAM Timing



5.3.5 Link Pulse Timing Characteristics

Table 5.12 shows the Link Pulse AC timing parameters. See Figure 5.15 and Figure 5.16 for the Link Pulse timing diagrams.

Table 5.12 Link Pulse Timing

Sym	Parameter	Limit			Unit	Condition
		Min	Typ	Max		
t61	NLP Transmit Link Pulse Width	See Figure 1.7			ns	
t62	NLP Transmit Link Pulse Period	8		24	ms	
t63	NLP Receive Link Pulse Width Required For Detection	50			ns	
t64	NLP Receive Link Pulse Minimum Period Required For Detection	6		7	ms	link_test_min
t65	NLP Receive Link Pulse Maximum Period Required For Detection	50		150	ms	link_test_max
t66	NLP Receive Link Pulses Required To Exit Link Fail State	3	3	3	Link Pulses	lc_max
t67	FLP Transmit Link Pulse Width	100		150	ns	
t68	FLP Transmit Clock Pulse To Data Pulse Period	55.5	62.5	69.5	μs	interval_timer
t69	FLP Transmit Clock Pulse To Clock Pulse Period	111	125	139	μs	
t70	FLP Transmit Link Pulse Burst Period	8		22	ms	transmit_link_burst_timer
t71	FLP Receive Link Pulse Width Required For Detection	50			ns	
t72	FLP Receive Link Pulse Minimum Period Required For Clock Pulse Detection	5		25	μs	flp_test_min_timer
t73	FLP Receive Link Pulse Maximum Period Required For Clock Pulse Detection	165		185	μs	flp_test_max_timer
t74	FLP Receive Link Pulse Minimum Period Required For Data Pulse Detection	15		47	μs	data_detect_min_timer
t75	FLP Receive Link Pulse Maximum Period Required For Data Pulse Detection	78		100	μs	data_detect_max_timer

Table 5.12 Link Pulse Timing (Cont.)

Sym	Parameter	Limit			Unit	Condition
		Min	Typ	Max		
t76	FLP Receive Link Pulses Required To Detect Valid FLP Burst	17		17	Link Pulses	
t77	FLP Receive Link Pulse Burst Minimum Period Required For Detection	5		7	ms	nlp_test_min_timer
t78	FLP Receive Link Pulse Burst Maximum Period Required For Detection	50		150	ms	nlp_test_max_timer
t79	FLP Receive Link Pulses Bursts Required To Detect AutoNegotiation Capability	3	3	3	Link Pulse	
t80	FLP Receive Acknowledge Fail Period	1200		1500	ms	
t81	FLP Transmit Renegotiate Link Fail Period	1200		1500	ms	break_link_timer
t82	NLP Receive Link Pulse Maximum Period Required For Detection After FLP Negotiation Has Completed	750		1000	ms	link_fail_inhibit_timer

Figure 5.15 NLP Link Pulse Timing

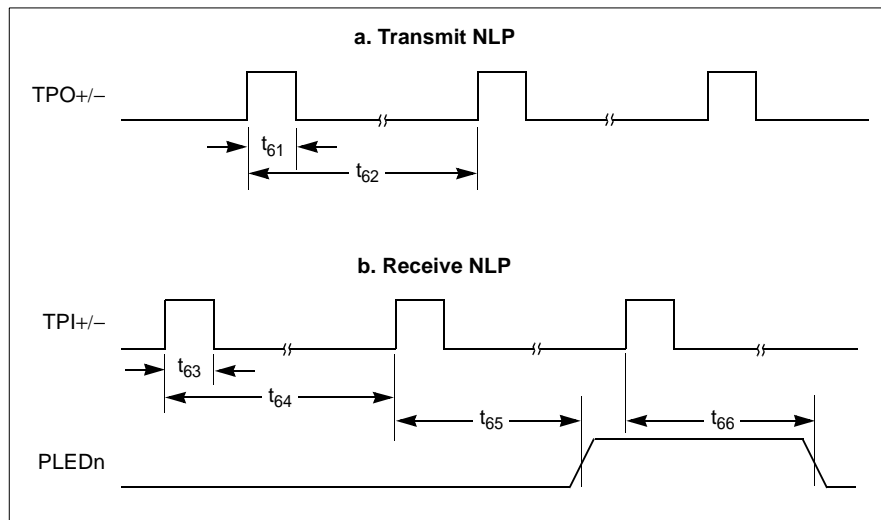
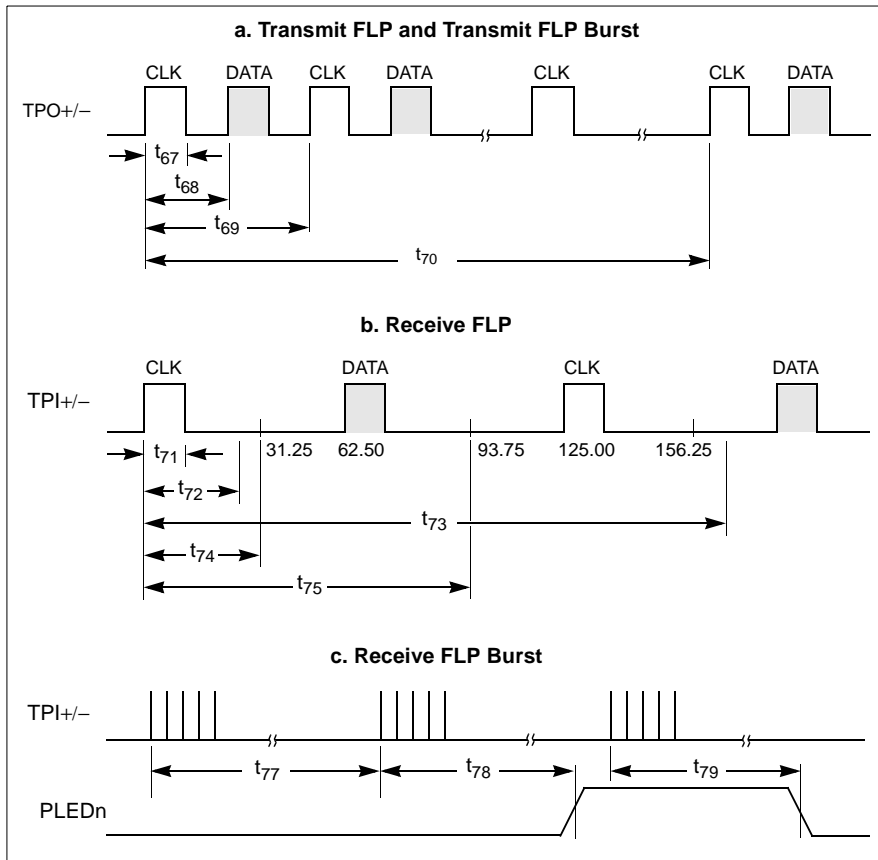

Figure 5.16 FLP Link Pulse Timing



5.3.6 Jabber Timing Characteristics

Table 5.13 shows the Jabber AC timing parameters. See Figure 5.17 for the Jabber timing diagram.

Table 5.13 Jabber Timing

Sym	Parameter	Limit			Unit	Conditions
		Min	Typ	Max		
t91	Jabber Activation Delay Time	50		100	ms	10 Mbits/s
t92	Jabber Deactivation Delay Time	250		750	ms	10 Mbits/s

Figure 5.17 Jabber Timing

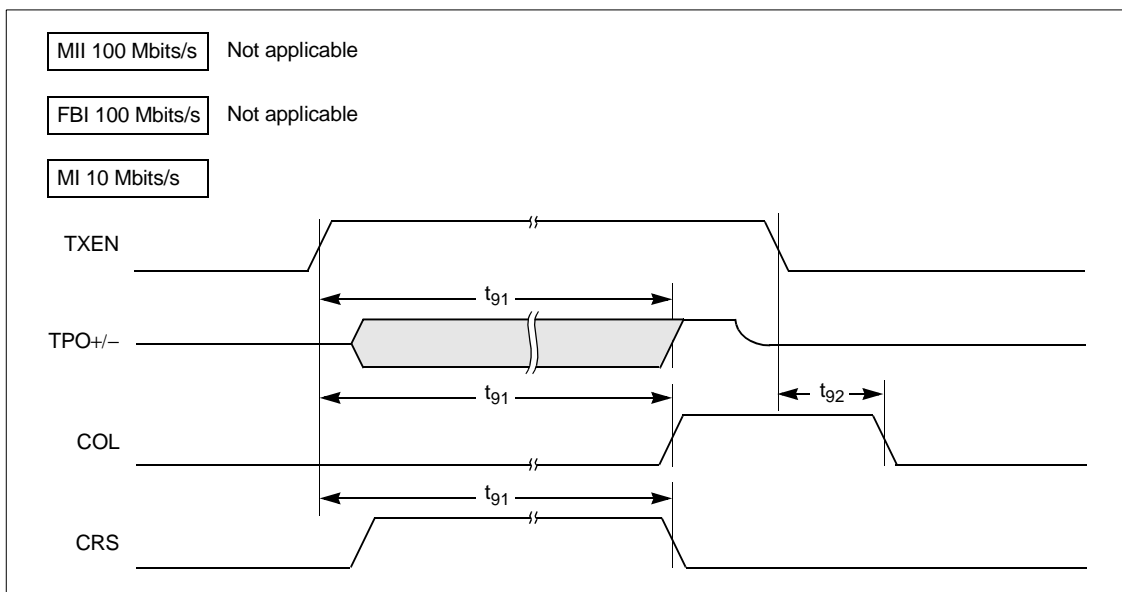

5.4 LED DRIVER TIMING CHARACTERISTICS

Table 5.14 shows the Jabber AC timing parameters. See Figure 5.18 for the Jabber timing diagram.

Table 5.14 LED Driver Timing

Sym	Parameter	Limit			Unit	Conditions
		Min	Typ	Max		
t96	PLED[5:0]n On Time	80		105	ms	PLED[5:0]n programmed to blink
t97	PLED[5:0]n Off Time	80		105	ms	PLED[5:0]n programmed to blink

Figure 5.18 LED Driver Timing

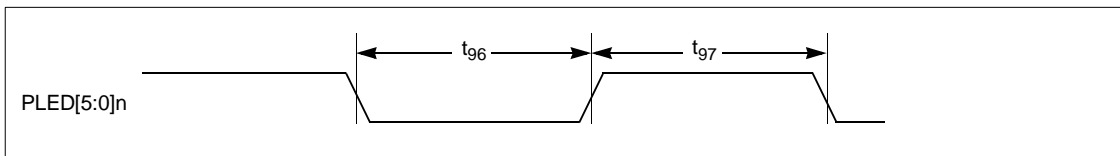

5.4.1 MI Serial Port Timing Characteristics

Table 5.15 shows the MI Serial Port AC timing parameters. See Figure 5.19 and Figure 5.20 for the associated timing diagram.

Table 5.15 MI Serial Port Timing

Sym	Parameter	Limit			Unit	Conditions
		Min	Typ	Max		
t101	MDC High Time	20			ns	
t102	MDC Low Time	20			ns	
t103	MDIO Setup Time	10			ns	Write bits
t104	MDIO Hold Time	10			ns	Write bits
t105	MDC To MDIO Delay			20	ns	Read bits
t106	MDIO Hi-Z To Active Delay			20	ns	Write-Read Bit Transition
t107	MDIO Active To HI-Z Delay			20	ns	Read-Write bit transition
t108	Frame Delimiter (Idle)	32			Clocks	Number of consecutive MDC clocks with MDIO = 1
t109	End Of Frame To MDINTn Transition			100	ns	
t110	MDC To MDIO Interrupt Pulse Assert Delay			100	ns	
t111	MDC To MDIO Interrupt Pulse Deassert Delay			100	ns	

Figure 5.19 MI Serial Port Timing

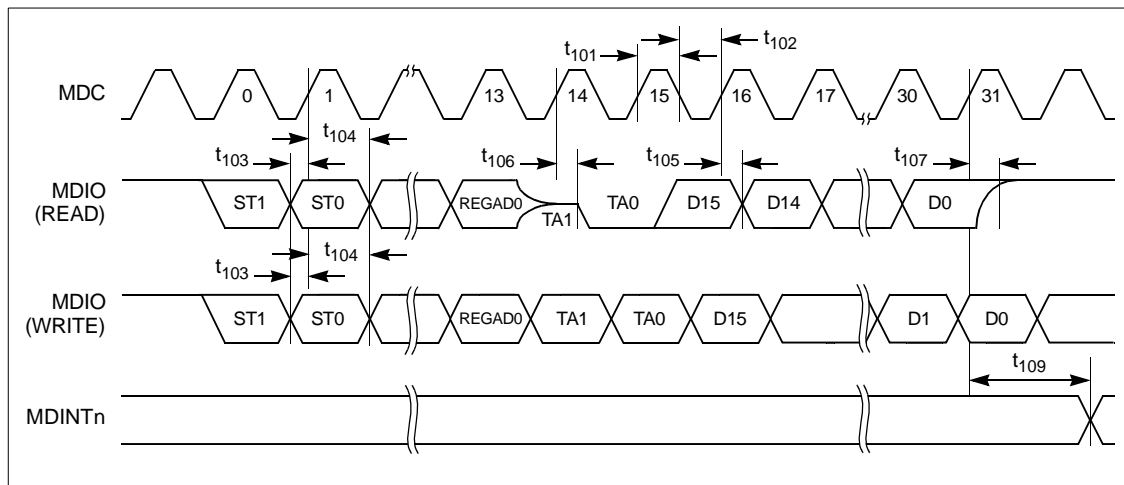
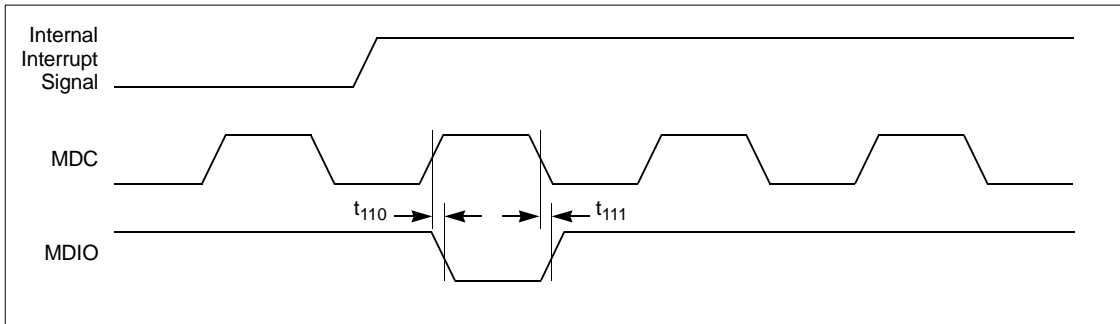

Figure 5.20 MDIO Interrupt Pulse Timing



5.5 PINOUTS AND PACKAGE DRAWINGS

This section contains the alphabetical and numerical pin listings for the LAN83C183 as well as its pinouts and package drawing.

5.5.1 Pinouts

Table 5.16 and Table 5.17 contain the list of LAN83C183 signals. The first table lists the signals by category and the second lists them by pin number.

Table 5.16 LAN83C183 Pin List (by Signal Category)

Pin Name	Pin Number	Description
Media Interface		
REXT	50	Transmit Current Set
SD/FXDISn	53	Signal Detect/FX Interface Disable
SD_THR	51	Signal Detect Input Threshold Level Set
TPI-/FXO+	59	Twisted Pair Receive Input, Negative/Fiber Pair Transmit Output, Positive
TPI+/FXO-	58	Twisted Pair Receive Input, Positive/Fiber Pair Transmit Output, Negative
TPO-/FXI+	55	Twisted Pair Transmit Output, Negative/Fiber Pair Transmit Input, Positive
TPO+/FXI-	54	Twisted Pair Transmit Output, Positive/Fiber Pair Transmit Input, Negative
Controller Interface		
CRS	13	Carrier Sense Output
OSCIN	42	Clock Oscillator Input
RX_CLK	26	Receive Clock Output
RX_DV	14	Receive Data Valid Output
RX_EN/JAMn	27	Receive Enable Input/JAM Input
RX_ER/RXD4	18	Receive Error Output/Fifth Receive Data Bit Output
RXD0	22	Receive Data Output.
RXD1	21	Receive Data Output.
RXD2	20	Receive Data Output.
RXD3	19	Receive Data Output
TX_CLK	34	Transmit Clock Output
TX_EN	40	Transmit Enable Input
TX_ER/TXD4	39	Transmit Error Input/Fifth Transmit Data Bit Input
TXD0	35	Transmit Data Input.
TXD1	36	Transmit Data Input.
TXD2	37	Transmit Data Input.
TXD3	38	Transmit Data Input
Management Interface (MI)		
MDC	10	Management Interface (MI) Clock Input
MDIO	11	Management Interface (MI) Data Input/Output
MDINTn/MDA4n	9	Management Interface (MI) Data Input/Output
PLED0n/MDA0n	61	Programmable LED Output /Management Interface Address Input.

Table 5.16 LAN83C183 Pin List (by Signal Category) (Cont.)

Pin Name	Pin Number	Description
PLED1n/MDA1n	62	Programmable LED Output /Management Interface Address Input
PLED2n/MDA2n	3	Programmable LED Output /Management Interface Address Input
PLED3n/MDA3n	4	Programmable LED Output /Management Interface Address Input
PLED4n	2	Programmable LED Output
PLED5n	63	Programmable LED Output
Miscellaneous		
ANEG	30	AutoNegotiation Input
COL	12	Collision Output
DPLX	29	Full/Half Duplex Select Input
RESETn	44	Reset Input
RPTR	24	Repeater Mode Enable Input
SPEED	28	Speed Select Input

Table 5.16 LAN83C183 Pin List (by Signal Category) (Cont.)

Pin Name	Pin Number	Description
Power		
V _{DD1}	56	Positive Supply. 3.3V ± 5% Volts
V _{DD2}	57	
V _{DD3}	7	
V _{DD4}	8	
V _{DD5}	25	
V _{DD6}	32	
Ground		
GND1	52	Ground
GND2	60	
GND3	6	
GND4	41	
GND5	23	
GND6	31	
No Connection		
NC	1	No Connection
NC	5	
NC	15	
NC	16	
NC	17	
NC	33	
NC	43	
NC	45	
NC	46	
NC	47	
NC	49	
NC	48	
NC	64	

Table 5.17 LAN83C183 Pin List (by Pin Number)

Pin Number	Pin Name	Description
1	NC	No Connection
2	PLED4n	Programmable LED Output
3	PLED2n/MDA2n	Programmable LED Output /Management Interface Address Input
4	PLED3n/MDA3n	Programmable LED Output /Management Interface Address Input
5	NC	No Connect
6	GND3	Ground
7	VDD3	Positive Supply. 3.3V \pm 5% Volts
8	VDD4	Positive Supply. 3.3V \pm 5% Volts
9	MDINTn/MDA4n	Management Interface (MI) Data Input/Output
10	MDC	Management Interface (MI) Clock Input
11	MDIO	Management Interface (MI) Data Input/Output
12	COL	Collision Output
13	CRS	Carrier Sense Output
14	RX_DV	Receive Data Valid Output
15	NC	No Connect
16	NC	No Connect
17	NC	No Connect
18	RX_ER/RXD4	Receive Error Output/Fifth Receive Data Bit Output
19	RXD3	Receive Data Output
20	RXD2	Receive Data Output.
21	RXD1	Receive Data Output.
22	RXD0	Receive Data Output.
23	GND5	Ground
24	RPTR	Repeater Mode Enable Input
25	VDD5	Positive Supply. 3.3V \pm 5% Volts
26	RX_CLK	Receive Clock Output
27	RX_EN/JAMn	Receive Enable Input
28	SPEED	Speed Select Input
29	DPLX	Full/Half Duplex Select Input
30	ANEG	AutoNegotiation Input
31	GND6	Ground
32	VDD6	Positive Supply. 3.3V \pm 5% Volts
33	NC	No Connect
34	TX_CLK	Transmit Clock Output
35	TXD0	Transmit Data Input.

Table 5.17 LAN83C183 Pin List (by Pin Number) (Cont.)

Pin Number	Pin Name	Description
36	TXD1	Transmit Data Input.
37	TXD2	Transmit Data Input.
38	TXD3	Transmit Data Input
39	TX_ER/TXD4	Transmit Error Input/Fifth Transmit Data Bit Input
40	TX_EN	Transmit Enable Input
41	GND4	Ground
42	OSCIN	Clock Oscillator Input
43	NC	No Connect
44	RESETn	Reset Input
45	NC	No Connect
46	NC	No Connect
47	NC	No Connect
48	NC	No Connect
49	NC	No Connect
50	REXT	Transmit Current Set
51	SD_THR	Signal Detect Input Threshold Level Set
52	GND1	Ground
53	SD/FXDISn	Signal Detect/FX Interface Disable
54	TPO+/FXI-	Twisted Pair Transmit Output, Positive/Fiber Pair Transmit Input, Negative
55	TPO-/FXI+	Twisted Pair Transmit Output, Negative/Fiber Pair Transmit Input, Positive
56	VDD1	Positive Supply. 3.3V ± 5% Volts
57	VDD2	Positive Supply. 3.3V ± 5% Volts
58	TPI+/FXO-	Twisted Pair Receive Input, Positive/Fiber Pair Transmit Output, Negative
59	TPI-/FXO+	Twisted Pair Receive Input, Negative/Fiber Pair Transmit Output, Positive
60	GND2	Ground
61	PLED0n/MDA0n	Programmable LED Output /Management Interface Address Input.
62	PLED1n/MDA1n	Programmable LED Output /Management Interface Address Input
63	PLED5n	Programmable LED Output
64	NC	No Connect

5.5.2 LAN83C183 Pin Layout

Figure 5.21 shows the pin layout for the LAN83C183 package.

Figure 5.21 LAN83C183 64-Pin LQFP, Top View

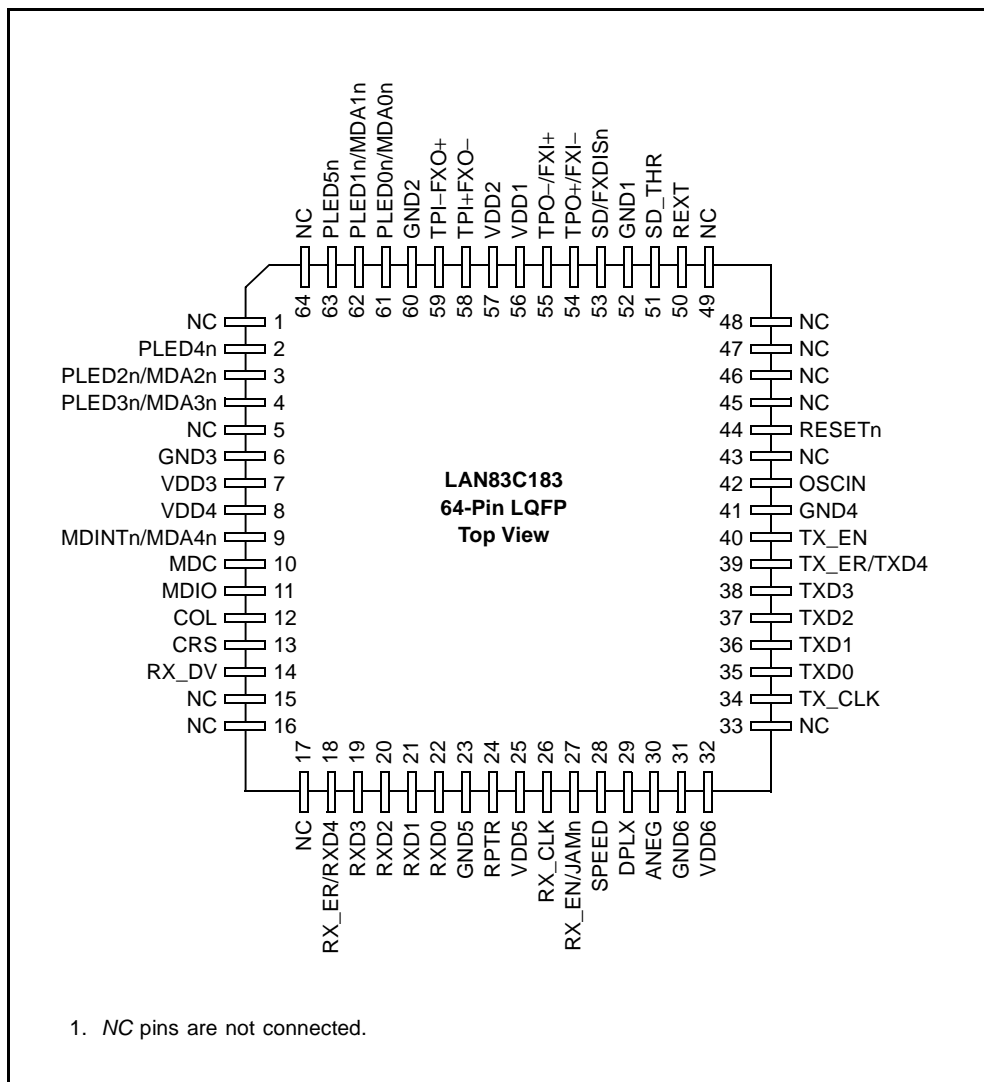

5.6 MECHANICAL DRAWING

This section contains the mechanical drawing for the LAN83C183 64-pin LQFP package.

Figure 5.22 64-Pin LQFP Mechanical Drawing

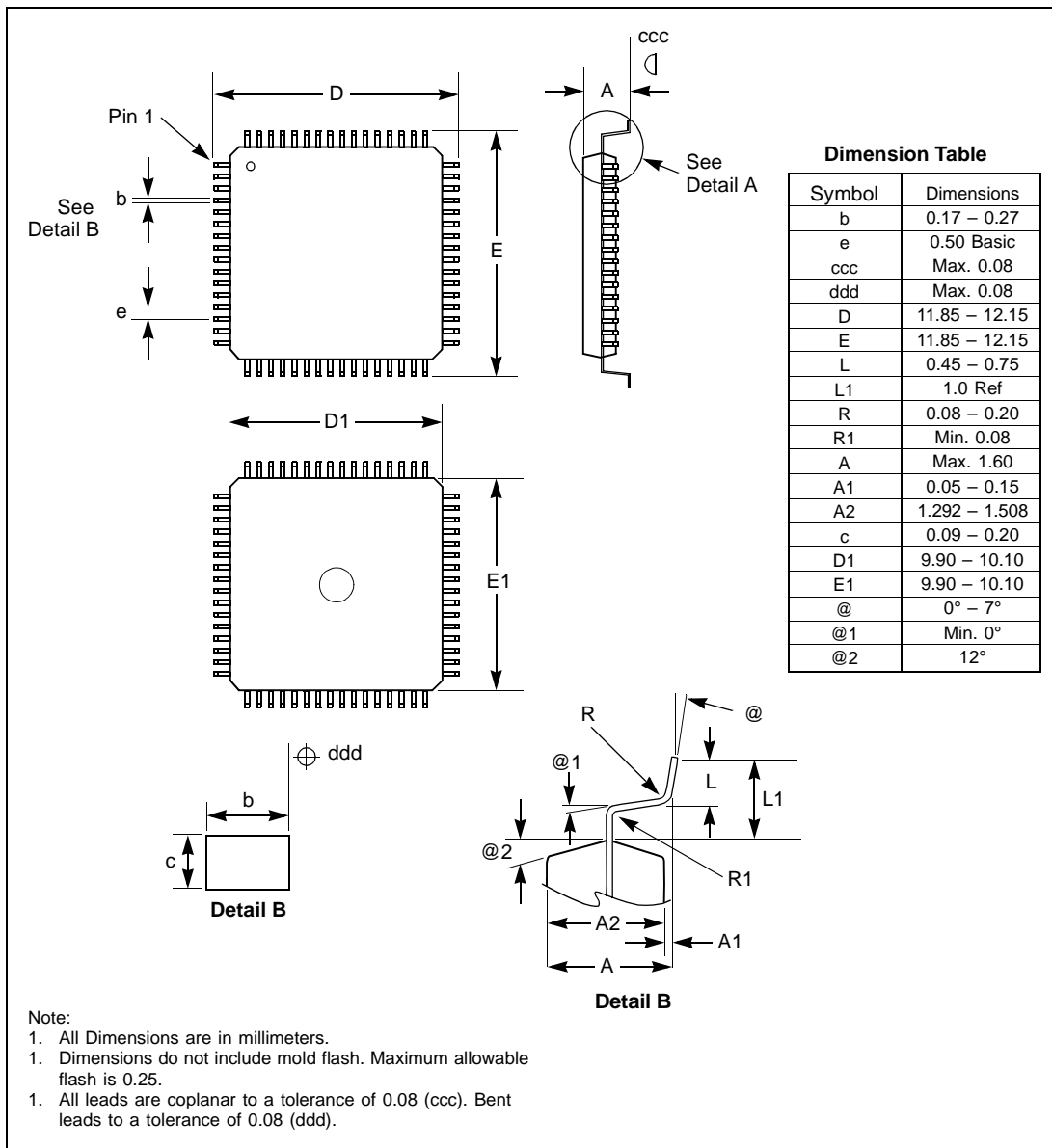

Important: This drawing may not be the latest version.