

2A POSITIVE VOLTAGE REGULATORS

- OUTPUT CURRENT TO 2A
- OUTPUT VOLTAGES OF 5 ; 7.5 ; 9 ; 10 ; 12 ; 15 ; 18 ; 24V
- THERMAL OVERLOAD PROTECTION
- SHORT CIRCUIT PROTECTION
- OUTPUT TRANSISTOR SOA PROTECTION

DESCRIPTION

The L78S00 series of three-terminal positive regulators is available in TO-220 and TO-3 packages and with several fixed output voltages, making it useful in a wide range of applications. These regulators can provide local on-card regulation, eliminating the distribution problems associated with single point regulation. Each type employs internal current limiting, thermal shut-down and safe area protection, making it essentially indestructible. If adequate heat sinking is provided, they can deliver over 2A output current. Although designed primarily as fixed voltage regulators, these devices can be used with external components to obtain adjustable voltages and currents.

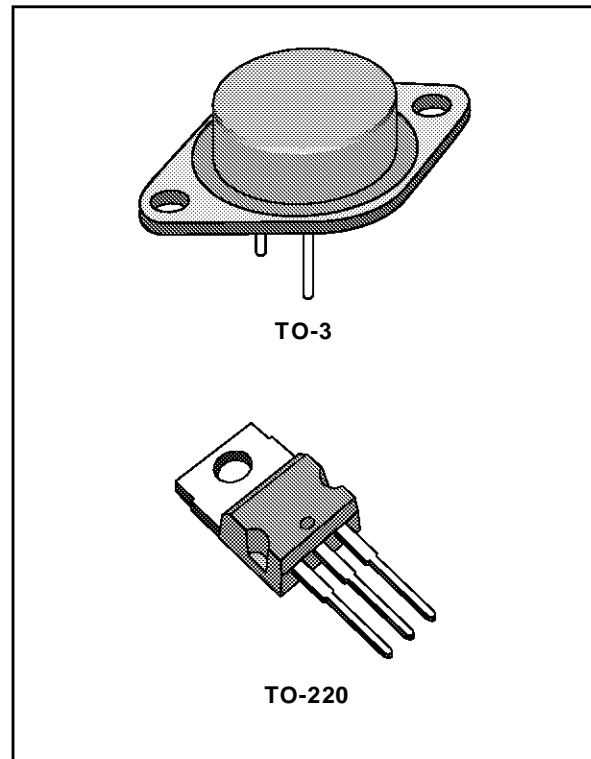

BLOCK DIAGRAM

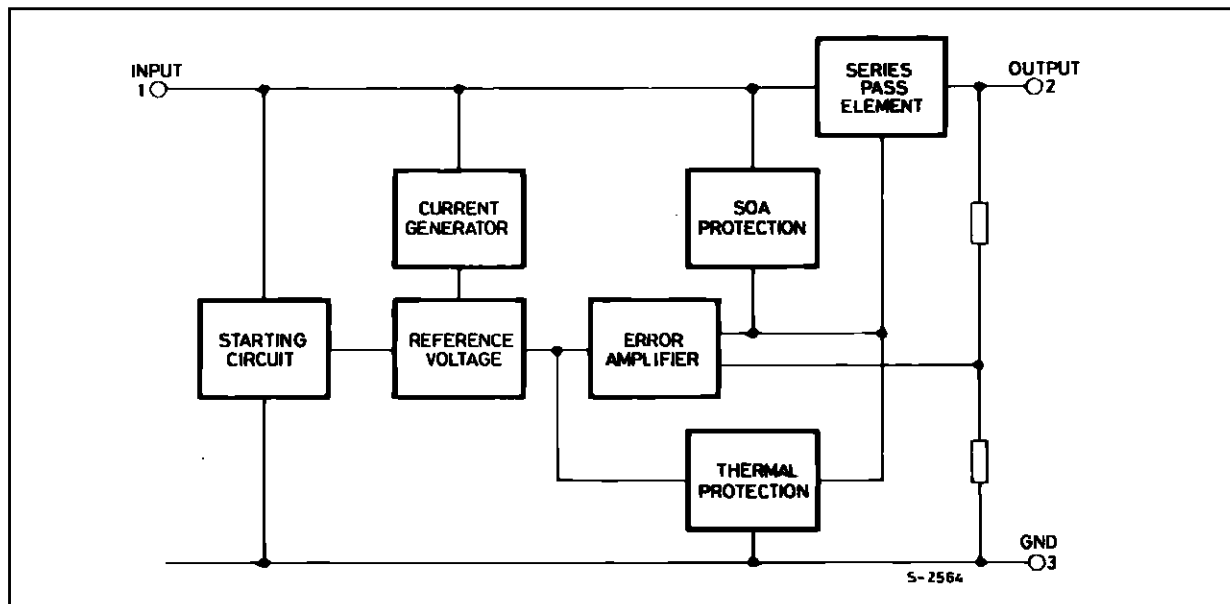

L78S00 SERIES

ABSOLUTE MAXIMUM RATINGS

Symbol	Parameter	Value	Unit
V_i	DC Input Voltage (for $V_o = 5$ to 18V) (for $V_o = 24$ V)	35	V
		40	V
I_o	Output Current	Internally limited	
P_{tot}	Power Dissipation	Internally limited	
T_{stg}	Storage Temperature	- 65 to + 150	°C
T_{op}	Operating Junction Temperature (for L78S00) (for L78S00C)	- 55 to + 150	°C
		0 to + 150	°C

THERMAL DATA

			TO-220	TO-3	
$R_{th\ j-case}$	Thermal Resistance Junction-case	Max	3	4	°C/W
$R_{th\ j-amb}$	Thermal Resistance Junction-ambient	Max	50	35	°C/W

CONNECTION DIAGRAMS AND ORDERING NUMBERS (top views)

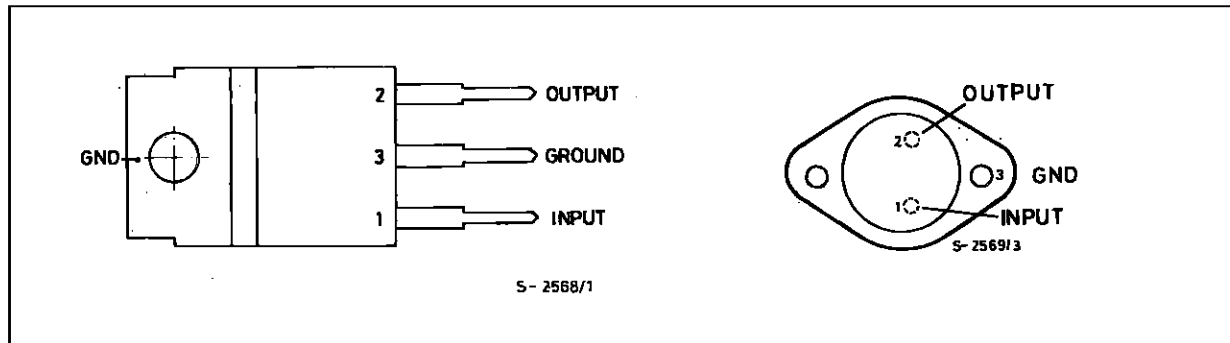

Type	TO-220	TO-3	Output Voltage
L78S05		L78S05T	5 V
L78S05C	L78S05CV	L78S05CT	5 V
L78S75		L78S75T	7.5V
L78S75C	L78S75CV	L78S75CT	7.5V
L78S09		L78S09T	9 V
L78S09C	L78S09CV	L78S09CT	9 V
L78S10		L78S10T	10V
L78S10C	L78S10CV	L78S10CT	10V
L78S12		L78S12T	12V
L78S12C	L78S12CV	L78S12CT	12V
L78S15		L78S15T	15V
L78S15C	L78S15CV	L78S15CT	15V
L78S18		L78S18T	18V
L78S18C	L78S18CV	L78S18CT	18V
L78S24		L78S24T	24V
L78S24C	L78S24CV	L78S24CT	24V

APPLICATION CIRCUIT

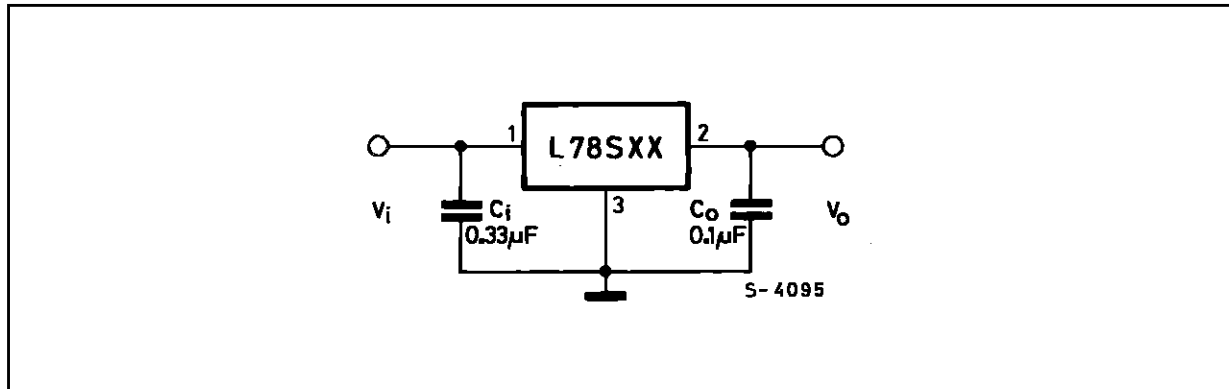

SCHEMATIC DIAGRAM

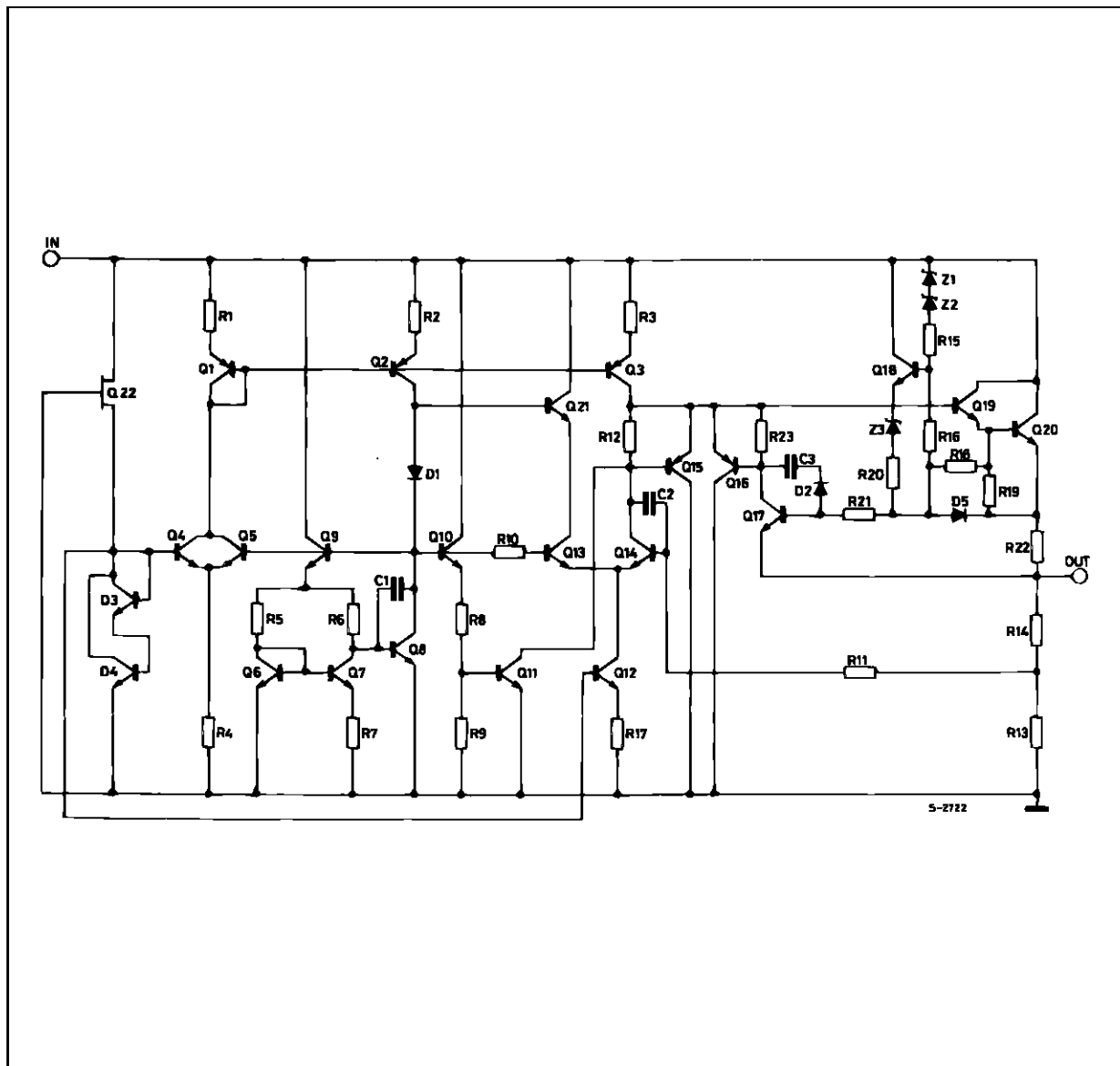

L78S00 SERIES

TEST CIRCUITS

Figure 1 : DC Parameters.

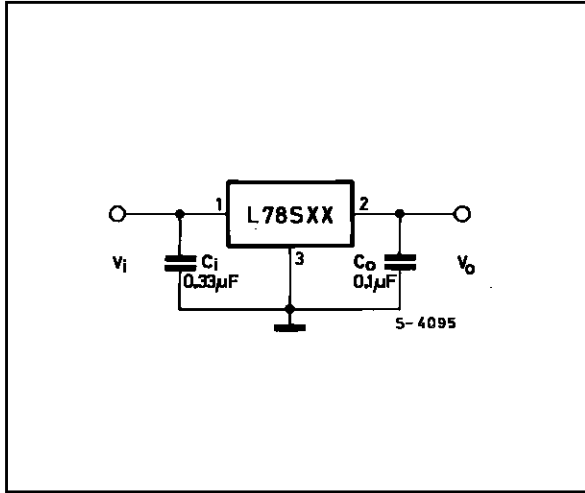

Figure 2 : Load Regulation.

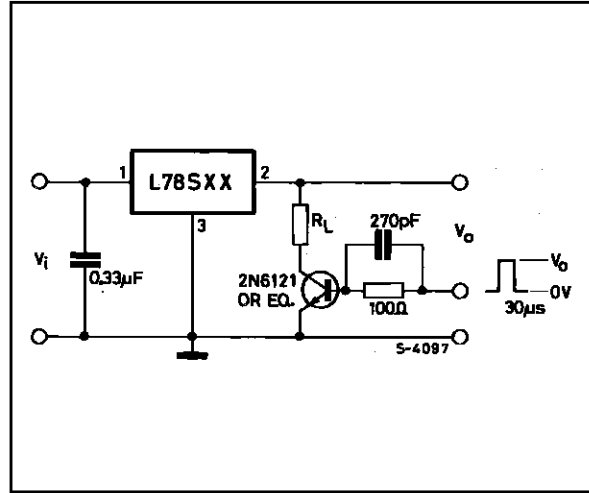
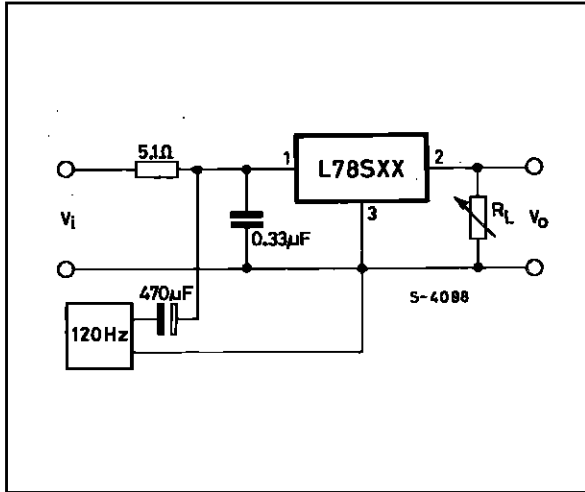

Figure 3 : Ripple Rejection.



ELECTRICAL CHARACTERISTICS FOR L78S05 (refer to the test circuits, $T_j = 25\text{ }^\circ\text{C}$, $V_i = 10\text{V}$, $I_o = 500\text{ mA}$ unless otherwise specified)

Symbol	Parameter	Test Conditions	Min.	Typ.	Max.	Unit
V_o	Output Voltage		4.8	5	5.2	V
V_o	Output Voltage	$I_o = 1\text{ A}$ $V_i = 7\text{ V}$	4.75	5	5.25	V
ΔV_o	Line Regulation	$V_i = 7\text{ to }25\text{ V}$ $V_i = 8\text{ to }25\text{ V}$			100 50	mV mV
ΔV_o	Load Regulation	$I_o = 20\text{ mA to }2\text{ A}$			100	mV
I_d	Quiescent Current				8	mA
ΔI_d	Quiescent Current Change	$I_o = 20\text{ mA to }1\text{ A}$			0.5	mA
ΔI_d	Quiescent Current Change	$I_o = 20\text{ mA}$ $V_i = 7\text{ to }25\text{ V}$			1.3	mA
$\frac{\Delta V_o}{\Delta T}$	Output Voltage Drift	$I_o = 5\text{ mA}$ $T_j = -55\text{ to }150\text{ }^\circ\text{C}$		-1.1		mV/ $^\circ\text{C}$
e_N	Output Noise Voltage	$B = 10\text{Hz to }100\text{KHz}$		40		μV
SVR	Supply Voltage Rejection	$f = 120\text{ Hz}$	60			dB
V_i	Operating Input Voltage	$I_o \leq 1.5\text{ A}$	8			V
R_o	Output Resistance	$f = 1\text{KHz}$		17		m Ω
I_{sc}	Short Circuit Current	$V_i = 27\text{ V}$		500		mA
I_{scp}	Short Circuit Peak Current			3		A

ELECTRICAL CHARACTERISTICS FOR L78S75 (refer to the test circuits, $T_j = 25\text{ }^\circ\text{C}$, $V_i = 12.5\text{V}$, $I_o = 500\text{ mA}$ unless otherwise specified)

Symbol	Parameter	Test Conditions	Min.	Typ.	Max.	Unit
V_o	Output Voltage		7.15	7.5	7.9	V
V_o	Output Voltage	$I_o = 1\text{ A}$ $V_i = 9.5\text{ V}$	7.1	7.5	7.95	V
ΔV_o	Line Regulation	$V_i = 9.5\text{ to }25\text{ V}$ $V_i = 10.5\text{ to }20\text{ V}$			120 60	mV mV
ΔV_o	Load Regulation	$I_o = 20\text{ mA to }2\text{ A}$			120	mV
I_d	Quiescent Current				8	mA
ΔI_d	Quiescent Current Change	$I_o = 20\text{ mA to }1\text{ A}$			0.5	mA
ΔI_d	Quiescent Current Change	$I_o = 20\text{ mA}$ $V_i = 9.5\text{ to }25\text{ V}$			1.3	mA
$\frac{\Delta V_o}{\Delta T}$	Output Voltage Drift	$I_o = 5\text{ mA}$ $T_j = -55\text{ to }150\text{ }^\circ\text{C}$		-0.8		mV/ $^\circ\text{C}$
e_N	Output Noise Voltage	$B = 10\text{Hz to }100\text{KHz}$		52		μV
SVR	Supply Voltage Rejection	$f = 120\text{ Hz}$	54			dB
V_i	Operating Input Voltage	$I_o \leq 1.5\text{ A}$	10.5			V
R_o	Output Resistance	$f = 1\text{KHz}$		16		m Ω
I_{sc}	Short Circuit Current	$V_i = 27\text{ V}$		500		mA
I_{scp}	Short Circuit Peak Current			3		A

L78S00 SERIES

ELECTRICAL CHARACTERISTICS FOR L78S09 (refer to the test circuits, $T_j = 25\text{ }^\circ\text{C}$,
 $V_i = 14\text{V}$, $I_o = 500\text{ mA}$ unless otherwise specified)

Symbol	Parameter	Test Conditions	Min.	Typ.	Max.	Unit
V_o	Output Voltage		8.65	9	9.35	V
V_o	Output Voltage	$I_o = 1\text{ A}$ $V_i = 11\text{ V}$	8.6	9	9.4	V
ΔV_o	Line Regulation	$V_i = 11\text{ to }25\text{ V}$ $V_i = 11\text{ to }20\text{ V}$			130 65	mV mV
ΔV_o	Load Regulation	$I_o = 20\text{ mA to }2\text{ A}$			130	mV
I_d	Quiescent Current				8	mA
ΔI_d	Quiescent Current Change	$I_o = 20\text{ mA to }1\text{ A}$			0.5	mA
ΔI_d	Quiescent Current Change	$I_o = 20\text{ mA}$ $V_i = 11\text{ to }25\text{ V}$			1.3	mA
$\frac{\Delta V_o}{\Delta T}$	Output Voltage Drift	$I_o = 5\text{ mA}$ $T_j = -55\text{ to }150\text{ }^\circ\text{C}$		-1		$\text{mV}/^\circ\text{C}$
e_N	Output Noise Voltage	$B = 10\text{Hz to }100\text{KHz}$		60		μV
SVR	Supply Voltage Rejection	$f = 120\text{ Hz}$	53			dB
V_i	Operating Input Voltage	$I_o \leq 1.5\text{ A}$	12			V
R_o	Output Resistance	$f = 1\text{KHz}$		17		$\text{m}\Omega$
I_{sc}	Short Circuit Current	$V_i = 27\text{ V}$		500		mA
I_{scp}	Short Circuit Peak Current			3		A

ELECTRICAL CHARACTERISTICS FOR L78S10 (refer to the test circuits, $T_j = 25\text{ }^\circ\text{C}$,
 $V_i = 15\text{V}$, $I_o = 500\text{ mA}$ unless otherwise specified)

Symbol	Parameter	Test Conditions	Min.	Typ.	Max.	Unit
V_o	Output Voltage		9.5	10	10.5	V
V_o	Output Voltage	$I_o = 1\text{ A}$ $V_i = 12.5\text{ V}$	9.4	10	10.6	V
ΔV_o	Line Regulation	$V_i = 12.5\text{ to }30\text{ V}$ $V_i = 14\text{ to }22\text{ V}$			200 100	mV mV
ΔV_o	Load Regulation	$I_o = 20\text{ mA to }2\text{ A}$			150	mV
I_d	Quiescent Current				8	mA
ΔI_d	Quiescent Current Change	$I_o = 20\text{ mA to }1\text{ A}$			0.5	mA
ΔI_d	Quiescent Current Change	$I_o = 20\text{ mA}$ $V_i = 12.5\text{ to }30\text{ V}$			1	mA
$\frac{\Delta V_o}{\Delta T}$	Output Voltage Drift	$I_o = 5\text{ mA}$ $T_j = -55\text{ to }150\text{ }^\circ\text{C}$		-1		$\text{mV}/^\circ\text{C}$
e_N	Output Noise Voltage	$B = 10\text{Hz to }100\text{KHz}$		65		μV
SVR	Supply Voltage Rejection	$f = 120\text{ Hz}$	53			dB
V_i	Operating Input Voltage	$I_o \leq 1.5\text{ A}$	13			V
R_o	Output Resistance	$f = 1\text{KHz}$		17		$\text{m}\Omega$
I_{sc}	Short Circuit Current	$V_i = 27\text{ V}$		500		mA
I_{scp}	Short Circuit Peak Current			3		A

ELECTRICAL CHARACTERISTICS FOR L78S12 (refer to the test circuits, $T_j = 25\text{ }^\circ\text{C}$, $V_i = 19\text{V}$, $I_o = 500\text{ mA}$ unless otherwise specified)

Symbol	Parameter	Test Conditions	Min.	Typ.	Max.	Unit
V_o	Output Voltage		11.5	12	12.5	V
V_o	Output Voltage	$I_o = 1\text{ A}$ $V_i = 14.5\text{ V}$	11.4	12	12.6	V
ΔV_o	Line Regulation	$V_i = 14.5\text{ to }30\text{ V}$ $V_i = 16\text{ to }22\text{ V}$			240 120	mV mV
ΔV_o	Load Regulation	$I_o = 20\text{ mA to }2\text{ A}$			160	mV
I_d	Quiescent Current				8	mA
ΔI_d	Quiescent Current Change	$I_o = 20\text{ mA to }1\text{ A}$			0.5	mA
ΔI_d	Quiescent Current Change	$I_o = 20\text{ mA}$ $V_i = 14.5\text{ to }30\text{ V}$			1	mA
$\frac{\Delta V_o}{\Delta T}$	Output Voltage Drift	$I_o = 5\text{ mA}$ $T_j = -55\text{ to }150\text{ }^\circ\text{C}$		-1		mV/ $^\circ\text{C}$
e_N	Output Noise Voltage	$B = 10\text{Hz to }100\text{KHz}$		75		μV
SVR	Supply Voltage Rejection	$f = 120\text{ Hz}$	53			dB
V_i	Operating Input Voltage	$I_o \leq 1.5\text{ A}$	15			V
R_o	Output Resistance	$f = 1\text{KHz}$		18		m Ω
I_{sc}	Short Circuit Current	$V_i = 27\text{ V}$		500		mA
I_{scp}	Short Circuit Peak Current			3		A

ELECTRICAL CHARACTERISTICS FOR L78S15 (refer to the test circuits, $T_j = 25\text{ }^\circ\text{C}$, $V_i = 23\text{V}$, $I_o = 500\text{ mA}$ unless otherwise specified)

Symbol	Parameter	Test Conditions	Min.	Typ.	Max.	Unit
V_o	Output Voltage		14.4	15	15.6	V
V_o	Output Voltage	$I_o = 1\text{ A}$ $V_i = 17.5\text{ V}$	14.25	15	15.75	V
ΔV_o	Line Regulation	$V_i = 17.5\text{ to }30\text{ V}$ $V_i = 20\text{ to }26\text{ V}$			300 150	mV mV
ΔV_o	Load Regulation	$I_o = 20\text{ mA to }2\text{ A}$			180	mV
I_d	Quiescent Current				8	mA
ΔI_d	Quiescent Current Change	$I_o = 20\text{ mA to }1\text{ A}$			0.5	mA
ΔI_d	Quiescent Current Change	$I_o = 20\text{ mA}$ $V_i = 17.5\text{ to }30\text{ V}$			1	mA
$\frac{\Delta V_o}{\Delta T}$	Output Voltage Drift	$I_o = 5\text{ mA}$ $T_j = -55\text{ to }150\text{ }^\circ\text{C}$		-1		mV/ $^\circ\text{C}$
e_N	Output Noise Voltage	$B = 10\text{Hz to }100\text{KHz}$		90		μV
SVR	Supply Voltage Rejection	$f = 120\text{ Hz}$	52			dB
V_i	Operating Input Voltage	$I_o \leq 1.5\text{ A}$	18			V
R_o	Output Resistance	$f = 1\text{KHz}$		19		m Ω
I_{sc}	Short Circuit Current	$V_i = 27\text{ V}$		500		mA
I_{scp}	Short Circuit Peak Current			3		A

L78S00 SERIES

ELECTRICAL CHARACTERISTICS FOR L78S18 (refer to the test circuits, $T_j = 25\text{ }^\circ\text{C}$,
 $V_i = 26\text{V}$, $I_o = 500\text{ mA}$ unless otherwise specified)

Symbol	Parameter	Test Conditions	Min.	Typ.	Max.	Unit
V_o	Output Voltage		17.1	18	18.9	V
V_o	Output Voltage	$I_o = 1\text{ A}$ $V_i = 20.5\text{ V}$	17	18	19	V
ΔV_o	Line Regulation	$V_i = 20.5\text{ to }30\text{ V}$ $V_i = 22\text{ to }28\text{ V}$			360 180	mV mV
ΔV_o	Load Regulation	$I_o = 20\text{ mA to }2\text{ A}$			200	mV
I_d	Quiescent Current				8	mA
ΔI_d	Quiescent Current Change	$I_o = 20\text{ mA to }1\text{ A}$			0.5	mA
ΔI_d	Quiescent Current Change	$I_o = 20\text{ mA}$ $V_i = 22\text{ to }33\text{ V}$			1	mA
$\frac{\Delta V_o}{\Delta T}$	Output Voltage Drift	$I_o = 5\text{ mA}$ $T_j = -55\text{ to }150\text{ }^\circ\text{C}$		-1		mV/ $^\circ\text{C}$
e_N	Output Noise Voltage	$B = 10\text{Hz to }100\text{KHz}$		110		μV
SVR	Supply Voltage Rejection	$f = 120\text{ Hz}$	49			dB
V_i	Operating Input Voltage	$I_o \leq 1.5\text{ A}$	21			V
R_o	Output Resistance	$f = 1\text{KHz}$		22		m Ω
I_{sc}	Short Circuit Current	$V_i = 27\text{ V}$		500		mA
I_{scp}	Short Circuit Peak Current			3		A

ELECTRICAL CHARACTERISTICS FOR L78S24 (refer to the test circuits, $T_j = 25\text{ }^\circ\text{C}$,
 $V_i = 33\text{V}$, $I_o = 500\text{ mA}$ unless otherwise specified)

Symbol	Parameter	Test Conditions	Min.	Typ.	Max.	Unit
V_o	Output Voltage		23	24	25	V
V_o	Output Voltage	$I_o = 1\text{ A}$ $V_i = 27\text{ V}$	22.8	24	25.2	V
ΔV_o	Line Regulation	$V_i = 27\text{ to }38\text{ V}$ $V_i = 30\text{ to }36\text{ V}$			480 240	mV mV
ΔV_o	Load Regulation	$I_o = 20\text{ mA to }2\text{ A}$			250	mV
I_d	Quiescent Current				8	mA
ΔI_d	Quiescent Current Change	$I_o = 20\text{ mA to }1\text{ A}$			0.5	mA
ΔI_d	Quiescent Current Change	$I_o = 20\text{ mA}$ $V_i = 8\text{ to }25\text{ V}$			1	mA
$\frac{\Delta V_o}{\Delta T}$	Output Voltage Drift	$I_o = 5\text{ mA}$ $T_j = -55\text{ to }150\text{ }^\circ\text{C}$		-1.5		mV/ $^\circ\text{C}$
e_N	Output Noise Voltage	$B = 10\text{Hz to }100\text{KHz}$		170		μV
SVR	Supply Voltage Rejection	$f = 120\text{ Hz}$	48			dB
V_i	Operating Input Voltage	$I_o \leq 1.5\text{ A}$	27			V
R_o	Output Resistance	$f = 1\text{KHz}$		23		m Ω
I_{sc}	Short Circuit Current	$V_i = 27\text{ V}$		500		mA
I_{scp}	Short Circuit Peak Current			3		A

ELECTRICAL CHARACTERISTICS FOR L78S05C (refer to the test circuits, $T_j = 25\text{ }^\circ\text{C}$, $V_i = 10\text{V}$, $I_o = 500\text{ mA}$ unless otherwise specified)

Symbol	Parameter	Test Conditions	Min.	Typ.	Max.	Unit
V_o	Output Voltage		4.8	5	5.2	V
V_o	Output Voltage	$I_o = 1\text{ A}$ $V_i = 7\text{ V}$	4.75	5	5.25	V
ΔV_o	Line Regulation	$V_i = 7\text{ to }25\text{ V}$ $V_i = 8\text{ to }12\text{ V}$			100 50	mV mV
ΔV_o	Load Regulation	$I_o = 20\text{ mA to }1.5\text{ A}$ $I_o = 2\text{ A}$		80	100	mV
I_d	Quiescent Current				8	mA
ΔI_d	Quiescent Current Change	$I_o = 20\text{ mA to }1\text{ A}$			0.5	mA
ΔI_d	Quiescent Current Change	$I_o = 20\text{ mA}$ $V_i = 7\text{ to }25\text{ V}$			1.3	mA
$\frac{\Delta V_o}{\Delta T}$	Output Voltage Drift	$I_o = 5\text{ mA}$ $T_j = 0\text{ to }70\text{ }^\circ\text{C}$		-1.1		mV/ $^\circ\text{C}$
e_N	Output Noise Voltage	$B = 10\text{Hz to }100\text{KHz}$		40		μV
SVR	Supply Voltage Rejection	$f = 120\text{ Hz}$	54			dB
V_i	Operating Input Voltage	$I_o \leq 1.5\text{ A}$	8			V
R_o	Output Resistance	$f = 1\text{KHz}$		17		m Ω
I_{sc}	Short Circuit Current	$V_i = 27\text{ V}$		500		mA
I_{scp}	Short Circuit Peak Current			3		A

ELECTRICAL CHARACTERISTICS FOR L78S75C (refer to the test circuits, $T_j = 25\text{ }^\circ\text{C}$, $V_i = 12.5\text{V}$, $I_o = 500\text{ mA}$ unless otherwise specified)

Symbol	Parameter	Test Conditions	Min.	Typ.	Max.	Unit
V_o	Output Voltage		7.15	7.5	7.9	V
V_o	Output Voltage	$I_o = 1\text{ A}$ $V_i = 9.5\text{ V}$	7.1	7.5	7.95	V
ΔV_o	Line Regulation	$V_i = 9.5\text{ to }25\text{ V}$ $V_i = 10.5\text{ to }20\text{ V}$			120 60	mV mV
ΔV_o	Load Regulation	$I_o = 20\text{ mA to }1.5\text{ A}$ $I_o = 2\text{ A}$		100	140	mV
I_d	Quiescent Current				8	mA
ΔI_d	Quiescent Current Change	$I_o = 20\text{ mA to }1\text{ A}$			0.5	mA
ΔI_d	Quiescent Current Change	$I_o = 20\text{ mA}$ $V_i = 9.5\text{ to }25\text{ V}$			1.3	mA
$\frac{\Delta V_o}{\Delta T}$	Output Voltage Drift	$I_o = 5\text{ mA}$ $T_j = 0\text{ to }70\text{ }^\circ\text{C}$		-0.8		mV/ $^\circ\text{C}$
e_N	Output Noise Voltage	$B = 10\text{Hz to }100\text{KHz}$		52		μV
SVR	Supply Voltage Rejection	$f = 120\text{ Hz}$	48			dB
V_i	Operating Input Voltage	$I_o \leq 1.5\text{ A}$	10.5			V
R_o	Output Resistance	$f = 1\text{KHz}$		16		m Ω
I_{sc}	Short Circuit Current	$V_i = 27\text{ V}$		500		mA
I_{scp}	Short Circuit Peak Current			3		A

L78S00 SERIES

ELECTRICAL CHARACTERISTICS FOR L78S09C (refer to the test circuits, $T_j = 25\text{ }^\circ\text{C}$,
 $V_i = 14\text{V}$, $I_o = 500\text{ mA}$ unless otherwise specified)

Symbol	Parameter	Test Conditions	Min.	Typ.	Max.	Unit
V_o	Output Voltage		8.65	9	9.35	V
V_o	Output Voltage	$I_o = 1\text{ A}$ $V_i = 11\text{ V}$	8.6	9	9.4	V
ΔV_o	Line Regulation	$V_i = 11\text{ to }25\text{ V}$ $V_i = 11\text{ to }20\text{ V}$			130 65	mV mV
ΔV_o	Load Regulation	$I_o = 20\text{ mA to }1.5\text{ A}$ $I_o = 2\text{ A}$		100	170	mV
I_d	Quiescent Current				8	mA
ΔI_d	Quiescent Current Change	$I_o = 20\text{ mA to }1\text{ A}$			0.5	mA
ΔI_d	Quiescent Current Change	$I_o = 20\text{ mA}$ $V_i = 11\text{ to }25\text{ V}$			1.3	mA
$\frac{\Delta V_o}{\Delta T}$	Output Voltage Drift	$I_o = 5\text{ mA}$ $T_j = 0\text{ to }70\text{ }^\circ\text{C}$		-1		$\text{mV}/^\circ\text{C}$
e_N	Output Noise Voltage	$B = 10\text{Hz to }100\text{KHz}$		60		μV
SVR	Supply Voltage Rejection	$f = 120\text{ Hz}$	47			dB
V_i	Operating Input Voltage	$I_o \leq 1.5\text{ A}$	12			V
R_o	Output Resistance	$f = 1\text{KHz}$		17		$\text{m}\Omega$
I_{sc}	Short Circuit Current	$V_i = 27\text{ V}$		500		mA
I_{scp}	Short Circuit Peak Current			3		A

ELECTRICAL CHARACTERISTICS FOR L78S10C (refer to the test circuits, $T_j = 25\text{ }^\circ\text{C}$,
 $V_i = 15\text{V}$, $I_o = 500\text{ mA}$ unless otherwise specified)

Symbol	Parameter	Test Conditions	Min.	Typ.	Max.	Unit
V_o	Output Voltage		9.5	10	10.5	V
V_o	Output Voltage	$I_o = 1\text{ A}$ $V_i = 12.5\text{ V}$	9.4	10	10.6	V
ΔV_o	Line Regulation	$V_i = 12.5\text{ to }30\text{ V}$ $V_i = 14\text{ to }22\text{ V}$			200 100	mV mV
ΔV_o	Load Regulation	$I_o = 20\text{ mA to }1.5\text{ A}$ $I_o = 2\text{ A}$		150	240	mV
I_d	Quiescent Current				8	mA
ΔI_d	Quiescent Current Change	$I_o = 20\text{ mA to }1\text{ A}$			0.5	mA
ΔI_d	Quiescent Current Change	$I_o = 20\text{ mA}$ $V_i = 12.5\text{ to }30\text{ V}$			1	mA
$\frac{\Delta V_o}{\Delta T}$	Output Voltage Drift	$I_o = 5\text{ mA}$ $T_j = 0\text{ to }70\text{ }^\circ\text{C}$		-1		$\text{mV}/^\circ\text{C}$
e_N	Output Noise Voltage	$B = 10\text{Hz to }100\text{KHz}$		65		μV
SVR	Supply Voltage Rejection	$f = 120\text{ Hz}$	47			dB
V_i	Operating Input Voltage	$I_o \leq 1.5\text{ A}$	13			V
R_o	Output Resistance	$f = 1\text{KHz}$		17		$\text{m}\Omega$
I_{sc}	Short Circuit Current	$V_i = 27\text{ V}$		500		mA
I_{scp}	Short Circuit Peak Current			3		A

ELECTRICAL CHARACTERISTICS FOR L78S12C (refer to the test circuits, $T_j = 25\text{ }^\circ\text{C}$, $V_i = 19\text{V}$, $I_o = 500\text{ mA}$ unless otherwise specified)

Symbol	Parameter	Test Conditions	Min.	Typ.	Max.	Unit
V_o	Output Voltage		11.5	12	12.5	V
V_o	Output Voltage	$I_o = 1\text{ A}$ $V_i = 14.5\text{ V}$	11.4	12	12.6	V
ΔV_o	Line Regulation	$V_i = 14.5\text{ to }30\text{ V}$ $V_i = 16\text{ to }22\text{ V}$			240 120	mV mV
ΔV_o	Load Regulation	$I_o = 20\text{ mA to }1.5\text{ A}$ $I_o = 2\text{ A}$		150	240	mV
I_d	Quiescent Current				8	mA
ΔI_d	Quiescent Current Change	$I_o = 20\text{ mA to }1\text{ A}$			0.5	mA
ΔI_d	Quiescent Current Change	$I_o = 20\text{ mA}$ $V_i = 14.5\text{ to }30\text{ V}$			1	mA
$\frac{\Delta V_o}{\Delta T}$	Output Voltage Drift	$I_o = 5\text{ mA}$ $T_j = 0\text{ to }70\text{ }^\circ\text{C}$		-1		mV/ $^\circ\text{C}$
e_N	Output Noise Voltage	$B = 10\text{Hz to }100\text{KHz}$		75		μV
SVR	Supply Voltage Rejection	$f = 120\text{ Hz}$	47			dB
V_i	Operating Input Voltage	$I_o \leq 1.5\text{ A}$	15			V
R_o	Output Resistance	$f = 1\text{KHz}$		18		m Ω
I_{sc}	Short Circuit Current	$V_i = 27\text{ V}$		500		mA
I_{scp}	Short Circuit Peak Current			3		A

ELECTRICAL CHARACTERISTICS FOR L78S15C (refer to the test circuits, $T_j = 25\text{ }^\circ\text{C}$, $V_i = 23\text{V}$, $I_o = 500\text{ mA}$ unless otherwise specified)

Symbol	Parameter	Test Conditions	Min.	Typ.	Max.	Unit
V_o	Output Voltage		14.4	15	15.6	V
V_o	Output Voltage	$I_o = 1\text{ A}$ $V_i = 17.5\text{ V}$	14.25	15	15.75	V
ΔV_o	Line Regulation	$V_i = 17.5\text{ to }30\text{ V}$ $V_i = 20\text{ to }26\text{ V}$			300 150	mV mV
ΔV_o	Load Regulation	$I_o = 20\text{ mA to }1.5\text{ A}$ $I_o = 2\text{ A}$		150	300	mV
I_d	Quiescent Current				8	mA
ΔI_d	Quiescent Current Change	$I_o = 20\text{ mA to }1\text{ A}$			0.5	mA
ΔI_d	Quiescent Current Change	$I_o = 20\text{ mA}$ $V_i = 17.5\text{ to }30\text{ V}$			1	mA
$\frac{\Delta V_o}{\Delta T}$	Output Voltage Drift	$I_o = 5\text{ mA}$ $T_j = 0\text{ to }70\text{ }^\circ\text{C}$		-1		mV/ $^\circ\text{C}$
e_N	Output Noise Voltage	$B = 10\text{Hz to }100\text{KHz}$		90		μV
SVR	Supply Voltage Rejection	$f = 120\text{ Hz}$	46			dB
V_i	Operating Input Voltage	$I_o \leq 1.5\text{ A}$	18			V
R_o	Output Resistance	$f = 1\text{KHz}$		19		m Ω
I_{sc}	Short Circuit Current	$V_i = 27\text{ V}$		500		mA
I_{scp}	Short Circuit Peak Current			3		A

L78S00 SERIES

ELECTRICAL CHARACTERISTICS FOR L78S18C (refer to the test circuits, $T_j = 25\text{ }^\circ\text{C}$, $V_i = 26\text{V}$, $I_o = 500\text{ mA}$ unless otherwise specified)

Symbol	Parameter	Test Conditions	Min.	Typ.	Max.	Unit
V_o	Output Voltage		17.1	18	18.9	V
V_o	Output Voltage	$I_o = 1\text{ A}$ $V_i = 20.5\text{ V}$	17	18	19	V
ΔV_o	Line Regulation	$V_i = 20.5\text{ to }30\text{ V}$ $V_i = 22\text{ to }28\text{ V}$			360 180	mV mV
ΔV_o	Load Regulation	$I_o = 20\text{ mA to }1.5\text{ A}$ $I_o = 2\text{ A}$		200	360	mV
I_d	Quiescent Current				8	mA
ΔI_d	Quiescent Current Change	$I_o = 20\text{ mA to }1\text{ A}$			0.5	mA
ΔI_d	Quiescent Current Change	$I_o = 20\text{ mA}$ $V_i = 20.5\text{ to }30\text{ V}$			1	mA
$\frac{\Delta V_o}{\Delta T}$	Output Voltage Drift	$I_o = 5\text{ mA}$ $T_j = 0\text{ to }70\text{ }^\circ\text{C}$		-1		mV/ $^\circ\text{C}$
e_N	Output Noise Voltage	$B = 10\text{Hz to }100\text{KHz}$		110		μV
SVR	Supply Voltage Rejection	$f = 120\text{ Hz}$	43			dB
V_i	Operating Input Voltage	$I_o \leq 1.5\text{ A}$	21			V
R_o	Output Resistance	$f = 1\text{KHz}$		22		m Ω
I_{sc}	Short Circuit Current	$V_i = 27\text{ V}$		500		mA
I_{scp}	Short Circuit Peak Current			3		A

ELECTRICAL CHARACTERISTICS FOR L78S24C (refer to the test circuits, $T_j = 25\text{ }^\circ\text{C}$, $V_i = 33\text{V}$, $I_o = 500\text{ mA}$ unless otherwise specified)

Symbol	Parameter	Test Conditions	Min.	Typ.	Max.	Unit
V_o	Output Voltage		23	24	25	V
V_o	Output Voltage	$I_o = 1\text{ A}$ $V_i = 27\text{ V}$	22.8	24	25.2	V
ΔV_o	Line Regulation	$V_i = 27\text{ to }38\text{ V}$ $V_i = 30\text{ to }36\text{ V}$			480 240	mV mV
ΔV_o	Load Regulation	$I_o = 20\text{ mA to }1.5\text{ A}$ $I_o = 2\text{ A}$		300	480	mV
I_d	Quiescent Current				8	mA
ΔI_d	Quiescent Current Change	$I_o = 20\text{ mA to }1\text{ A}$			0.5	mA
ΔI_d	Quiescent Current Change	$I_o = 20\text{ mA}$ $V_i = 27\text{ to }38\text{ V}$			1	mA
$\frac{\Delta V_o}{\Delta T}$	Output Voltage Drift	$I_o = 5\text{ mA}$ $T_j = 0\text{ to }70\text{ }^\circ\text{C}$		-1.5		mV/ $^\circ\text{C}$
e_N	Output Noise Voltage	$B = 10\text{Hz to }100\text{KHz}$		170		μV
SVR	Supply Voltage Rejection	$f = 120\text{ Hz}$	42			dB
V_i	Operating Input Voltage	$I_o \leq 1.5\text{ A}$	27			V
R_o	Output Resistance	$f = 1\text{KHz}$		28		m Ω
I_{sc}	Short Circuit Current	$V_i = 27\text{ V}$		500		mA
I_{scp}	Short Circuit Peak Current			3		A

Figure 4 : Dropout Voltage vs. Junction Temperature.

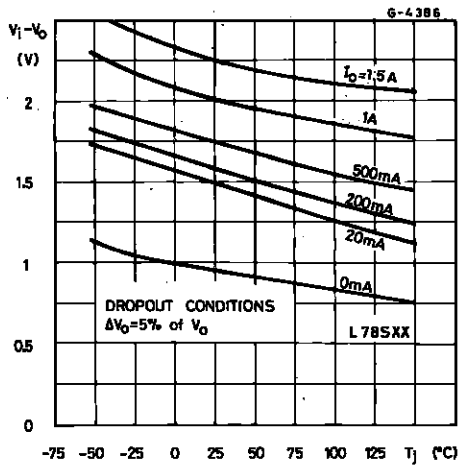

Figure 5 : Peak Output Current vs. Input/Output Differential Voltage.

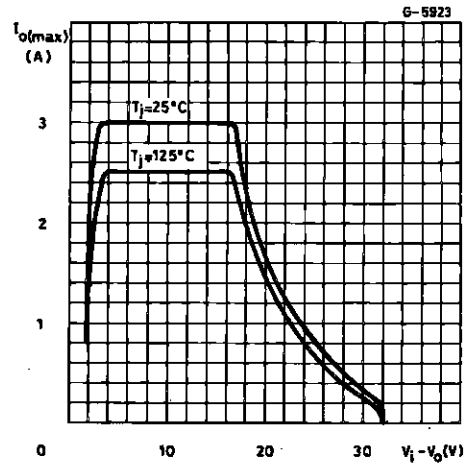

Figure 6 : Supply Voltage Rejection vs. Frequency.

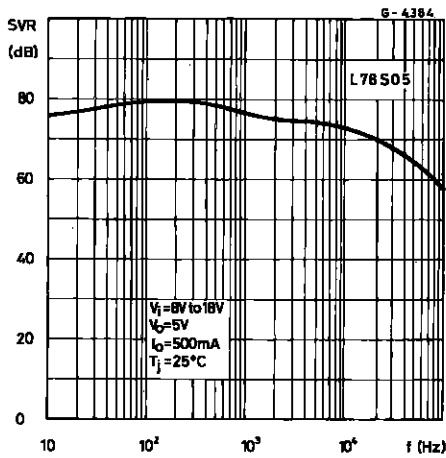

Figure 7 : Output Voltage vs. Junction Temperature.

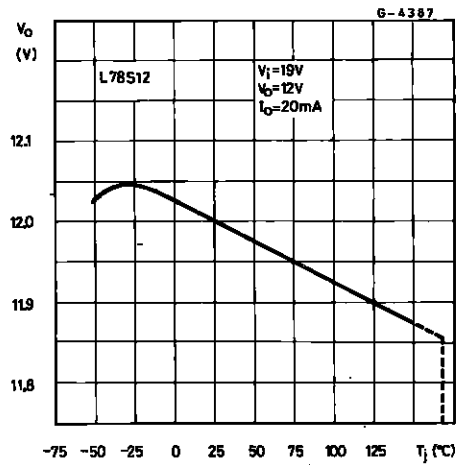

Figure 8 : Output Impedance vs. Frequency.

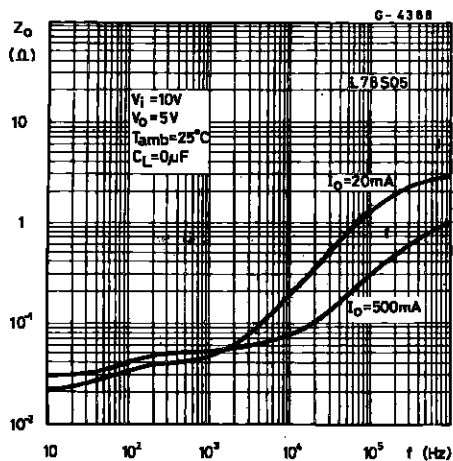
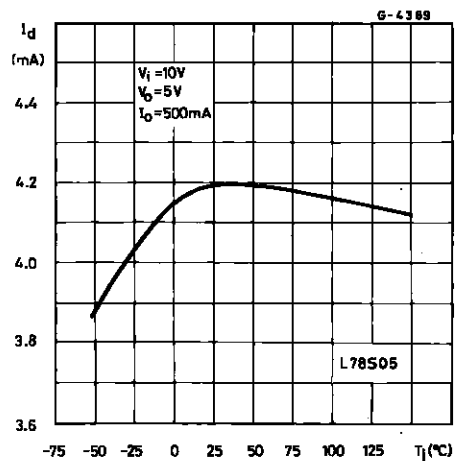

Figure 9 : Quiescent Current vs. Junction Temperature.



L78S00 SERIES

Figure 10 : Load Transient Response.

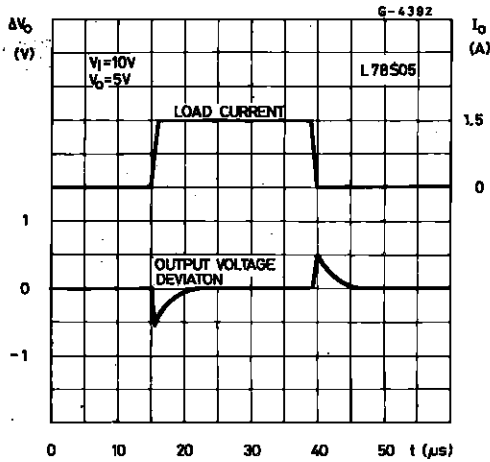

Figure 11 : Line Transient Response.

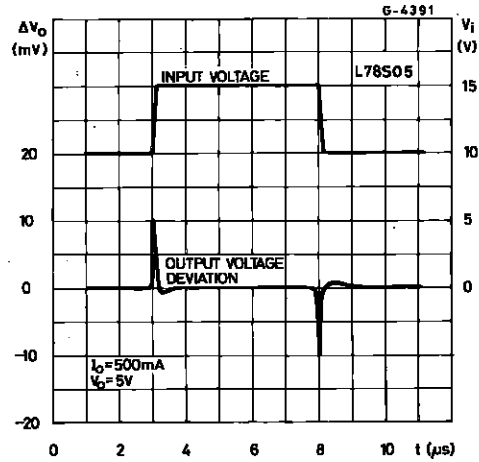

Figure 12 : Quiescent Current vs. Input Voltage.

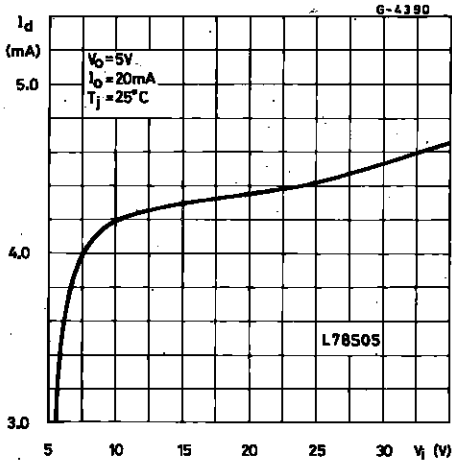

Figure 13 : Fixed Output Regulator.

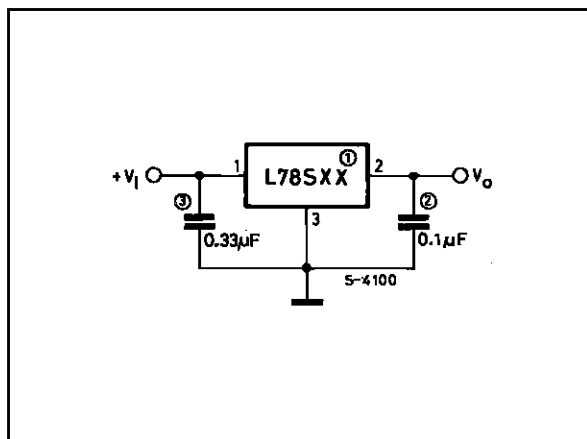
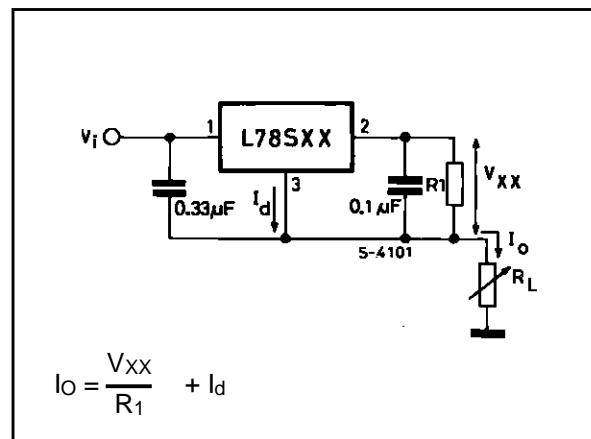

Figure 14 : Constant Current Regulator.



- Notes :
1. To specify an output voltage, substitute voltage value for "XX".
 2. Although no output capacitor is needed for stability, it does improve transient response.
 3. Required if regulator is located an appreciable distance from power supply filter.

Figure 15 : Circuit for Increasing Output Voltage.

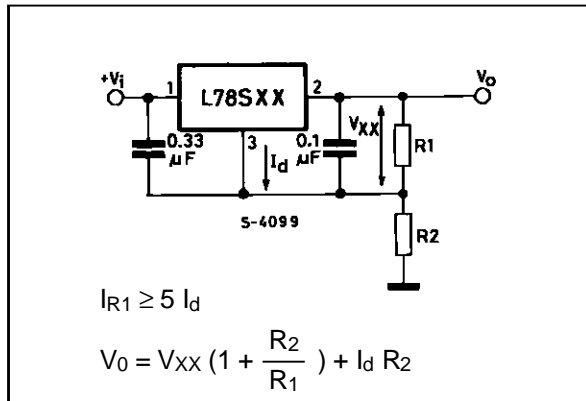

Figure 16 : Adjustable Output Regulator (7 to 30V).

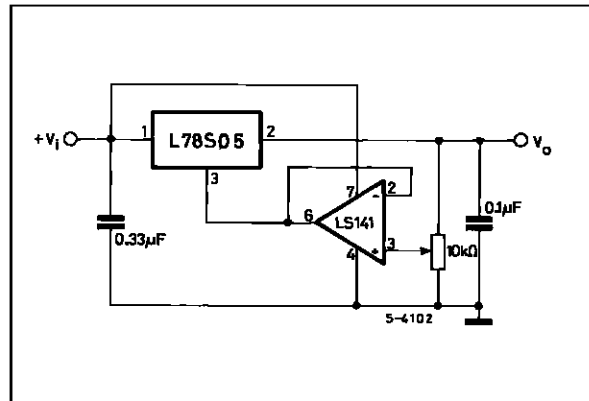

Figure 17 : 0.5 to 10V Regulator.

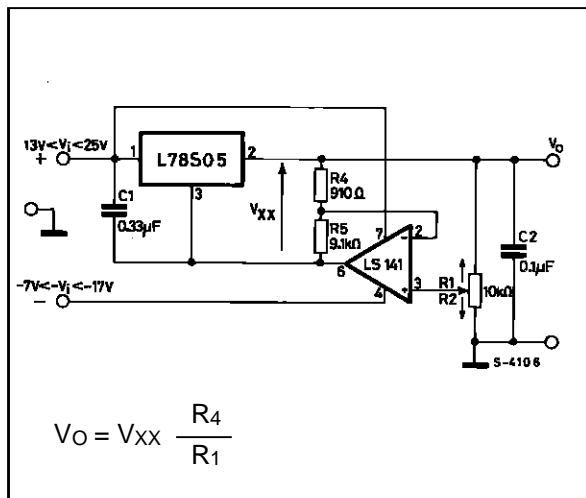

Figure 18 : High Current Voltage Regulator.

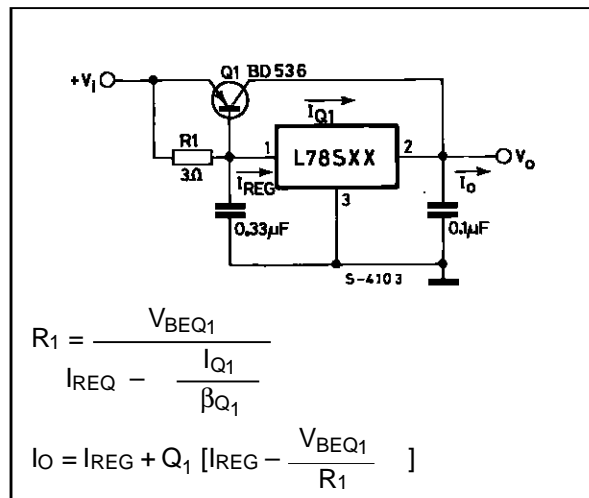

Figure 19 : High Output Current with Short Circuit Protection.

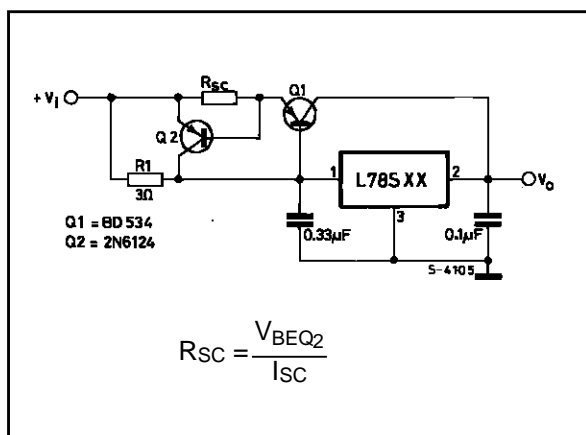
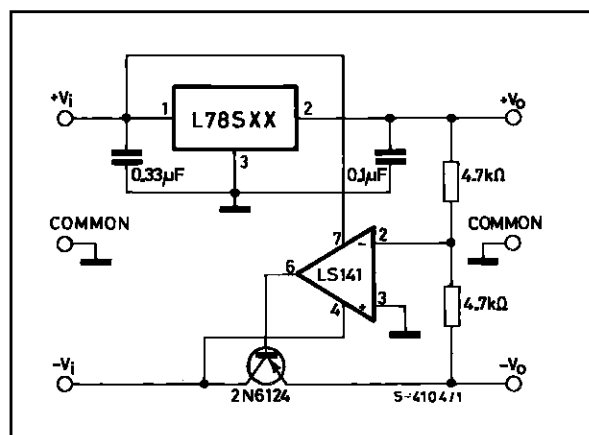
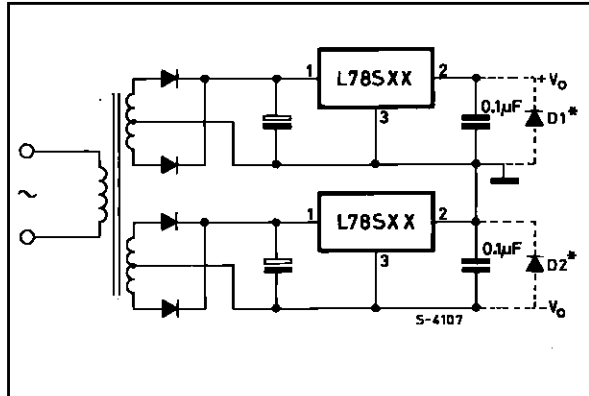

Figure 20 : Tracking Voltage Regulator.



L78S00 SERIES

Figure 21 : Positive and Negative Regulator.



(*) D₁ and D₂ are necessary if the load is connected between +V_o and -V_o.

Figure 22 : Negative Output Voltage Circuit.

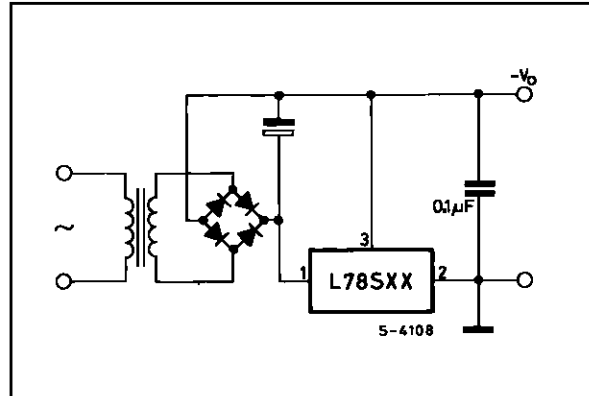

Figure 23 : Switching Regulator.

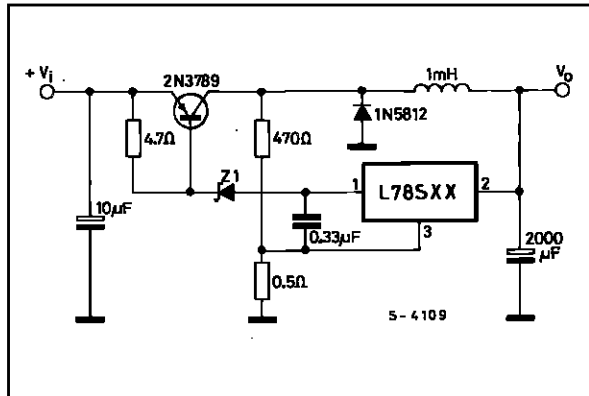
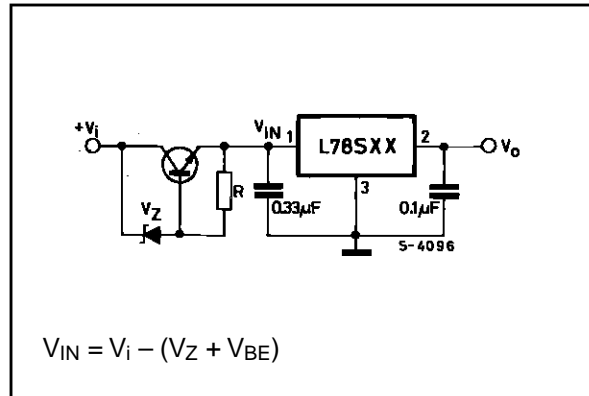
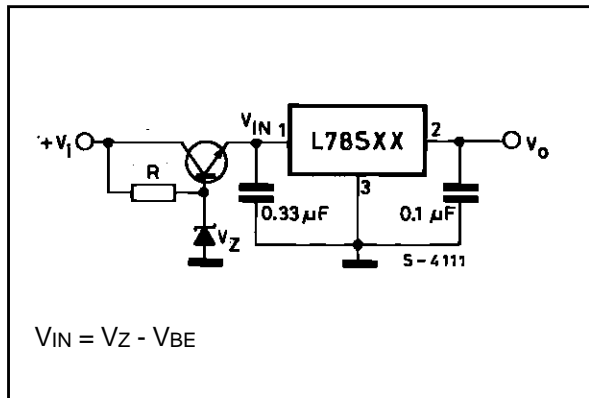

Figure 24 : High Input Voltage Circuit.



$$V_{IN} = V_i - (V_Z + V_{BE})$$

Figure 25 : High Input Voltage Circuit.



$$V_{IN} = V_Z - V_{BE}$$

Figure 26 : High Output Voltage Regulator.

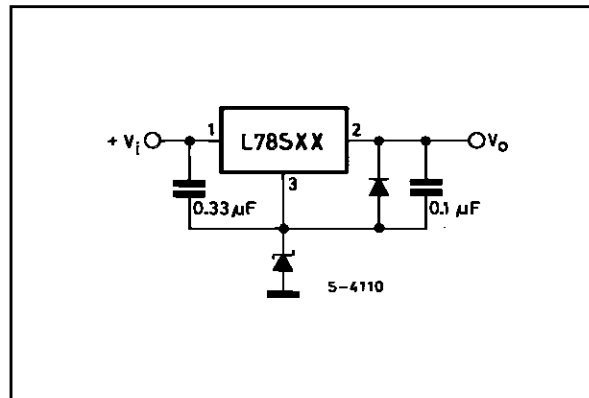

Figure 27 : High Input and Output Voltage.

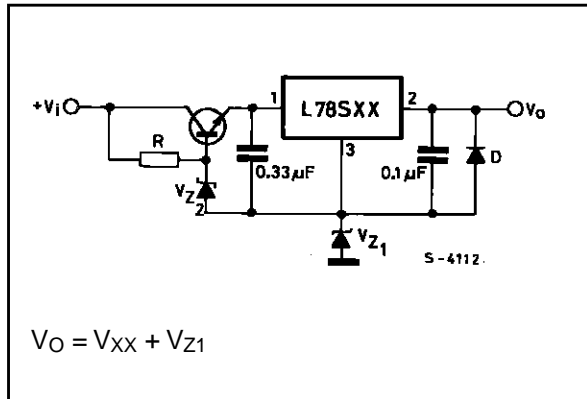

Figure 28 : Reducing Power Dissipation with Dropping Resistor.

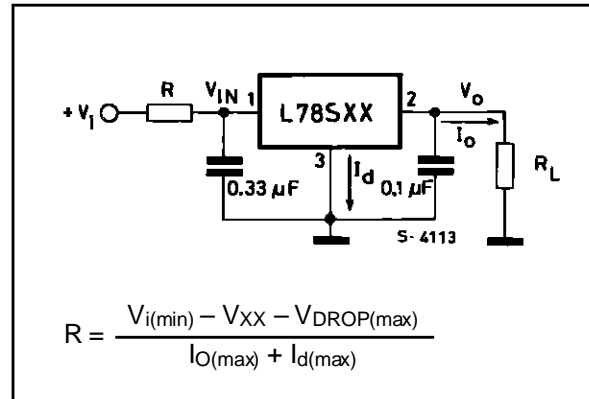

Figure 29 : Remote Shutdown.

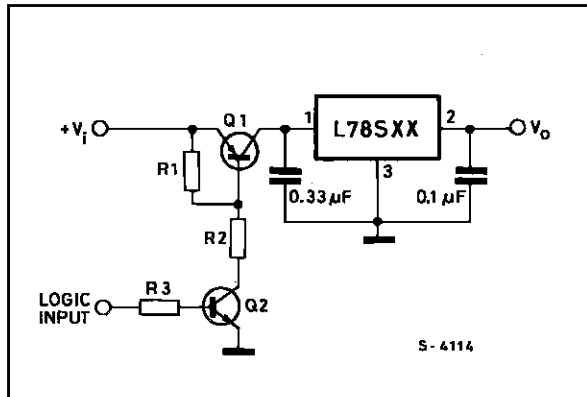
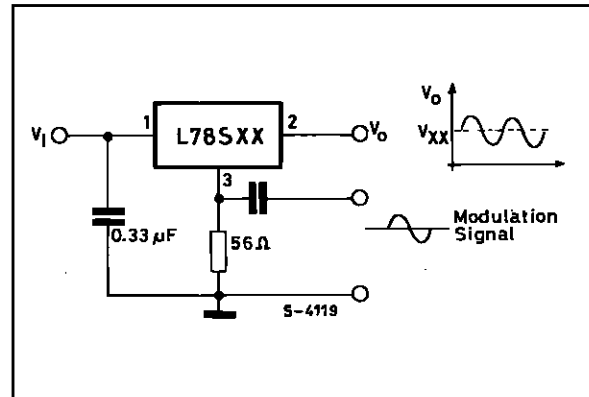
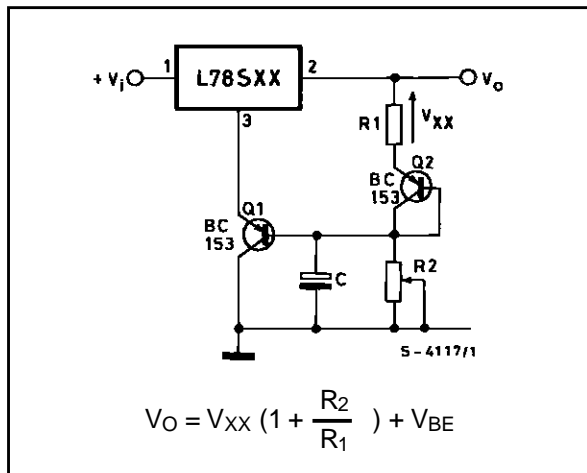

Figure 30 : Power AM Modulator (unity voltage gain, $I_o \leq 1A$).



Note : The circuit performs well up to 100KHz.

Figure 31 : Adjustable Output Voltage with Temperature Compensation.



Note : Q₂ is connected as a diode in order to compensate the variation of the Q₁ V_{BE} with the temperature. C allows a slow rise-time of the V_o

L78S00 SERIES

Figure 32 : Light Controllers ($V_{O \min} = V_{xx} + V_{BE}$).

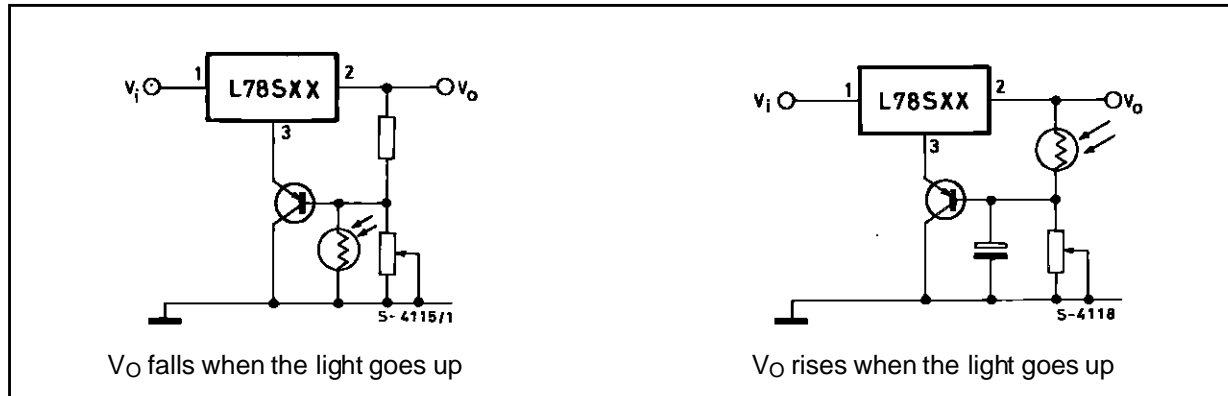
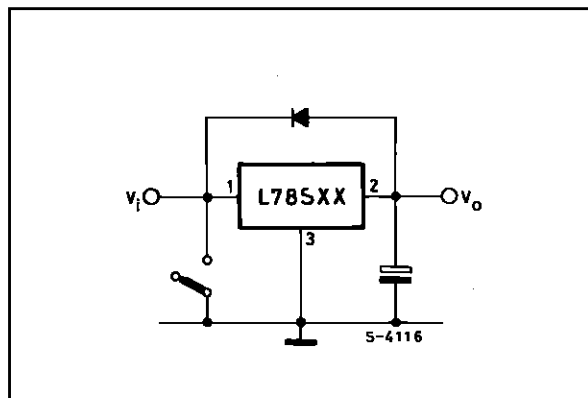

Figure 33 : Protection against Input Short-circuit with High Capacitance Loads.



Applications with high capacitance loads and an output voltage greater than 6 volts need an external diode (see fig. 33) to protect the device against input short circuit. In this case the input voltage falls rapidly while the output voltage decreases slowly. The capacitance discharges by means of the Base-Emitter junction of the series pass transistor in the regulator. If the energy is sufficiently high, the transistor may be destroyed. The external diode bypasses the current from the IC to ground.

TO-3 MECHANICAL DATA

DIM.	mm			inch		
	MIN.	TYP.	MAX.	MIN.	TYP.	MAX.
A	11.00		13.10	0.433		0.516
B	0.97		1.15	0.038		0.045
C	1.50		1.65	0.059		0.065
D	8.32		8.92	0.327		0.351
E	19.00		20.00	0.748		0.787
G	10.70		11.10	0.421		0.437
N	16.50		17.20	0.649		0.677
P	25.00		26.00	0.984		1.023
R	4.00		4.09	0.157		0.161
U	38.50		39.30	1.515		1.547
V	30.00		30.30	1.187		1.193

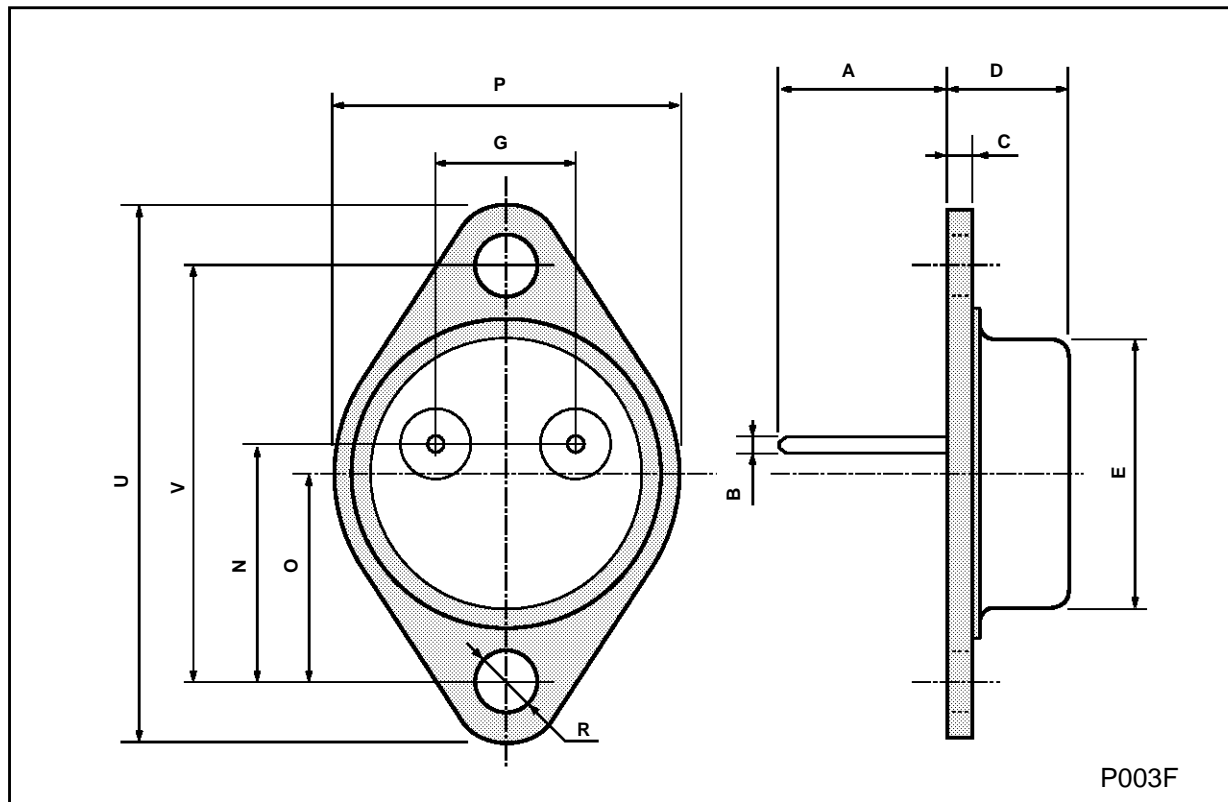

L78S00 SERIES

TO-220 MECHANICAL DATA

DIM.	mm			inch		
	MIN.	TYP.	MAX.	MIN.	TYP.	MAX.
A	4.40		4.60	0.173		0.181
C	1.23		1.32	0.048		0.051
D	2.40		2.72	0.094		0.107
D1		1.27			0.050	
E	0.49		0.70	0.019		0.027
F	0.61		0.88	0.024		0.034
F1	1.14		1.70	0.044		0.067
F2	1.14		1.70	0.044		0.067
G	4.95		5.15	0.194		0.203
G1	2.4		2.7	0.094		0.106
H2	10.0		10.40	0.393		0.409
L2		16.4			0.645	
L4	13.0		14.0	0.511		0.551
L5	2.65		2.95	0.104		0.116
L6	15.2		15.9	0.598		0.625
L7	6.2		6.6	0.244		0.260
L9	3.5		4.2	0.137		0.165
DIA.	3.75		3.85	0.147		0.151

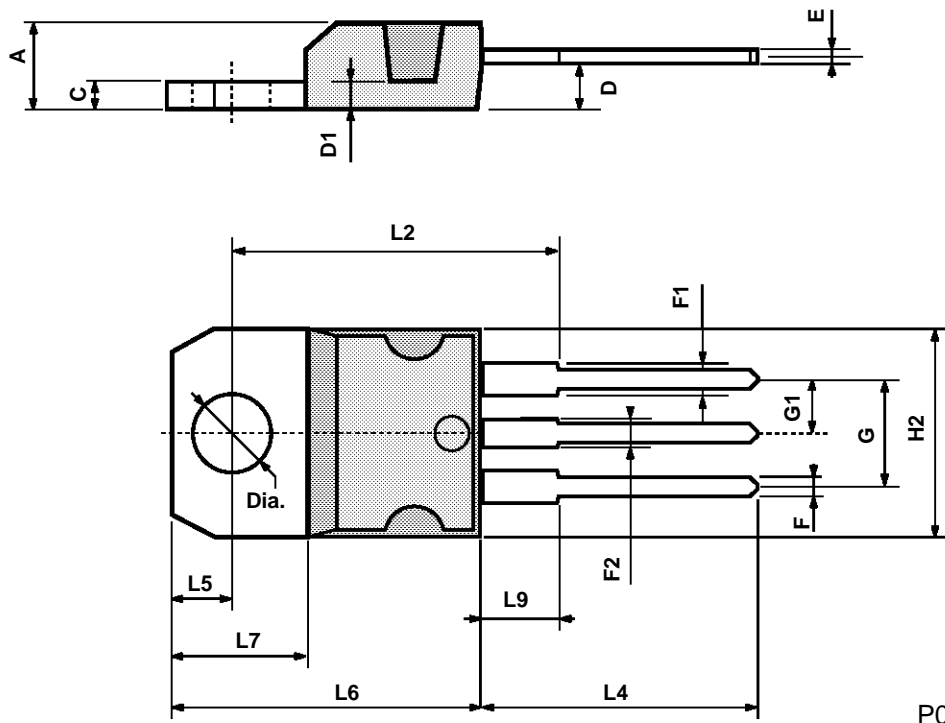

P011C

Information furnished is believed to be accurate and reliable. However, SGS-THOMSON Microelectronics assumes no responsibility for the consequences of use of such information nor for any infringement of patents or other rights of third parties which may result from its use. No license is granted by implication or otherwise under any patent or patent rights of SGS-THOMSON Microelectronics. Specifications mentioned in this publication are subject to change without notice. This publication supersedes and replaces all information previously supplied. SGS-THOMSON Microelectronics products are not authorized for use as critical components in life support devices or systems without express written approval of SGS-THOMSON Microelectronics.

© 1994 SGS-THOMSON Microelectronics - All Rights Reserved

SGS-THOMSON Microelectronics GROUP OF COMPANIES

Australia - Brazil - France - Germany - Hong Kong - Italy - Japan - Korea - Malaysia - Malta - Morocco - The Netherlands -
Singapore - Spain - Sweden - Switzerland - Taiwan - Thailand - United Kingdom - U.S.A