

KBPC15W SERIES

SINGLE-PHASE SILICON BRIDGE

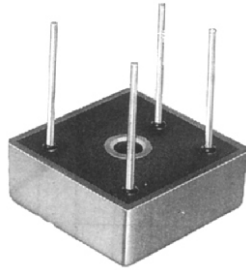

**CHENG-YI
ELECTRONIC**



FEATURES

- Surge overload rating-300 amperes peak
- Low forward voltage drop
- Mounting Position: Any
- Electrically isolated base-1800 Volts
- Solder cooper leads .040" diameter
- Materials use carries U/L recognition

VOLTAGE RANGE
50 TO 1000 VOLTS PRV
CURRENT
15 Amperes

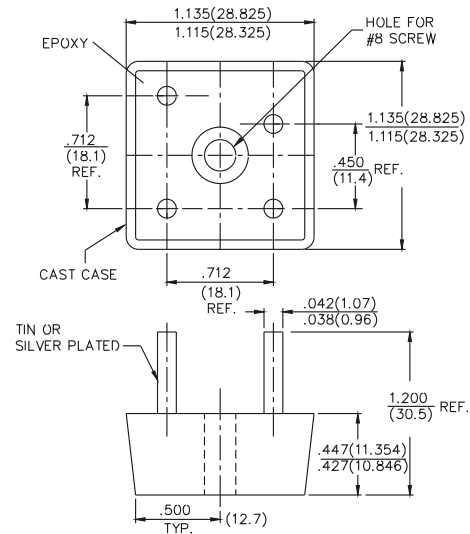

Dimensions in inches and (millimeters)

MAXIMUM RATINGS AND ELECTRICAL CHARACTERISTICS

Ratings at 25°C ambient temperature unless otherwise specified.
Resistive or inductive load, 60 Hz. For capacitive load, derate current by 20%.

		KBPC 15005W	KBPC 1501W	KBPC 1502W	KBPC 1504W	KBPC 1506W	KBPC 1508W	KBPC 1510W	UNITS
Maximum Recurrent Peak Reverse Voltage	V_{RRM}	50	100	200	400	600	800	1000	V
Maximum RMS Bridge Input Voltage	V_{RMS}	35	70	140	280	420	560	700	V
Maximum DC Blocking Voltage	V_{DC}	50	100	200	400	600	800	1000	V
Maximum Average Forward Output Current @ $T_C=55^\circ C$	$I_{(AV)}$	15							A
Peak Forward Surge Current 8.3 ms single half sine-wave superimposed on rated load(JEDEC Mehtod)	I_{FSM}	250							A
Maximum DC Forward Voltage drop per element at 7.5A DC	V_F	1.2							V
Maximum DC Reverse Current @ $T_A=25^\circ C$ at rated DC Blocking Voltage @ $T_A=100^\circ C$	I_R	10 1							μA μA
$I^2 t$ Rating for fusing ($t < 8.3ms$)	$I^2 t$	373							A ² S
Typical Thermal Resistance(Note.1)	$R\theta_{JC}$	2.5							$^\circ C/W$
Operating Temperature Range	T_J	-55 to +125							$^\circ C$
Storage Temperature Range	T_{STG}	-55 to +150							$^\circ C$

KBPC15W SERIES

SINGLE-PHASE SILICON BRIDGE



**CHENG-YI
ELECTRONIC**

RATING AND CHARACTERISTICS CURVES KBPC15W SERIES

Fig.1 - MAXIMUM FORWARD SURGE CURRENT

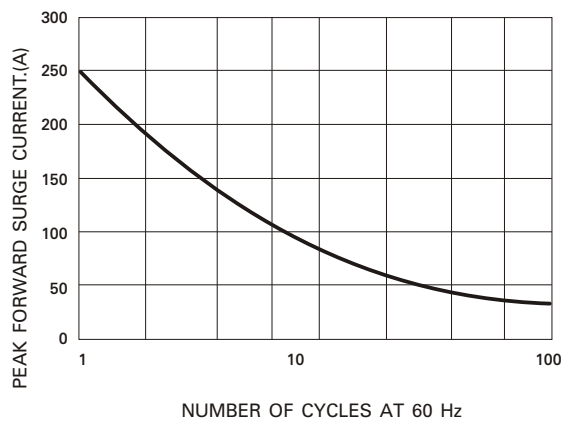

Fig.2 - DERATING CURVE FOR
OUTPUT RECTIFIED CURRENT

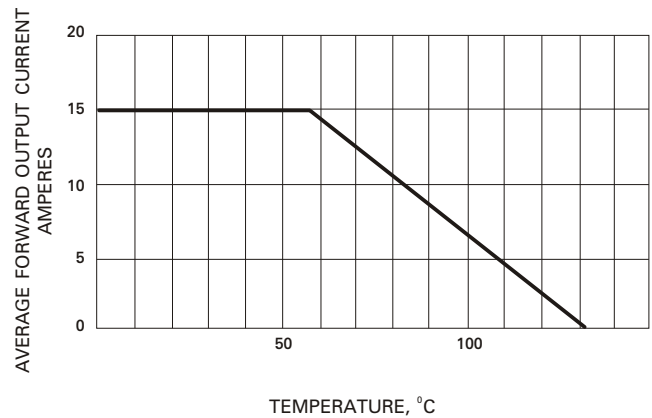

Fig.3 - TYPICAL FORWARD
CHARACTERISTICS

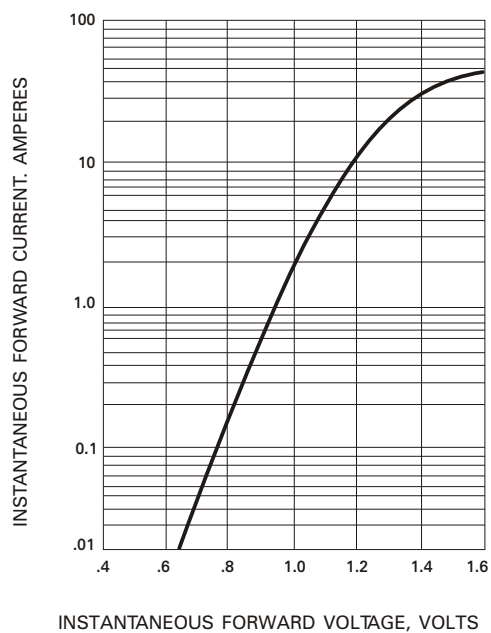

Fig.4 - TYPICAL REVERSE
CHARACTERISTICS

