

**μPFC™**

**SOT-23 Boost PFC Control IC**

**Features**

- Critical-conduction mode PFC control
- High PF and ultra-low THD
- Wide load and line range
- Regulated and programmable DC bus voltage
- No secondary winding required
- MOSFET cycle-by-cycle over-current protection
- DC bus over-voltage protection
- Low EMI gate drive
- Ultra-low start-up current
- 20.8V internal zener clamp on VCC
- Excellent ESD and latch immunity
- RoHS compliant
- 5-pin SOT-23 package

**Description**

The IRS2505 is a control IC for boost-type PFC circuits operating in critical-conduction mode. The IC incorporates a free-running frequency oscillator with on- and off-time control of the boost power MOSFET without the need for a secondary winding. Also included in the design is over-voltage protection of the DC bus and cycle-by-cycle over-current protection of the power MOSFET. Micro-power start-up current and an internal 20.8V zener clamp at VCC are provided to simplify the external VCC supply circuitry. ESD and latch immune CMOS technology enables a rugged monolithic IC construction.

**Applications**

- Off-line power supply
- Electronic ballast
- LED power supply

**Package Options**



**Application Diagram**

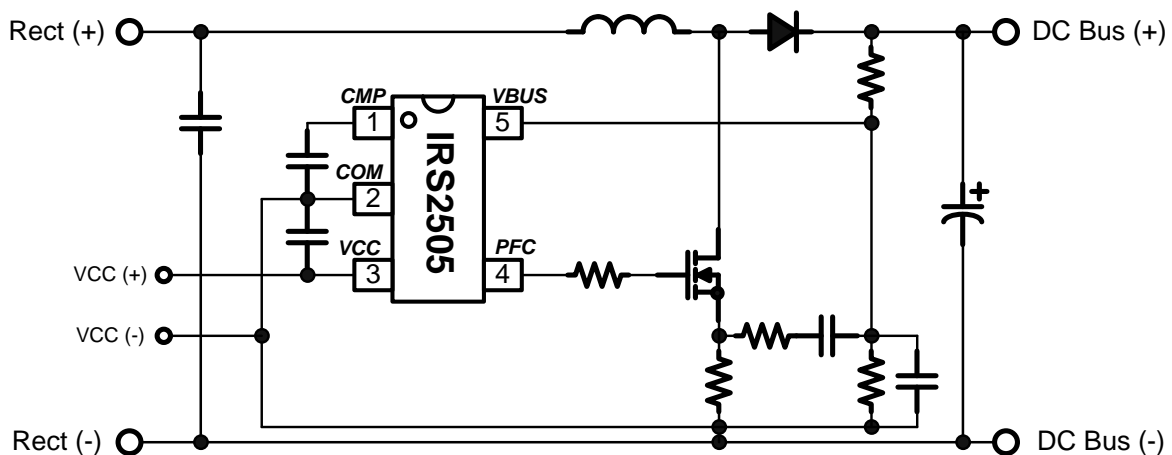

**Ordering Information**

Base Part Number	Package Type	Standard Pack		Orderable Part Number
		Form	Quantity	
IRS2505LPBF	5L-SOT-23	Tape and Reel	3000	IRS2505LTRPBF

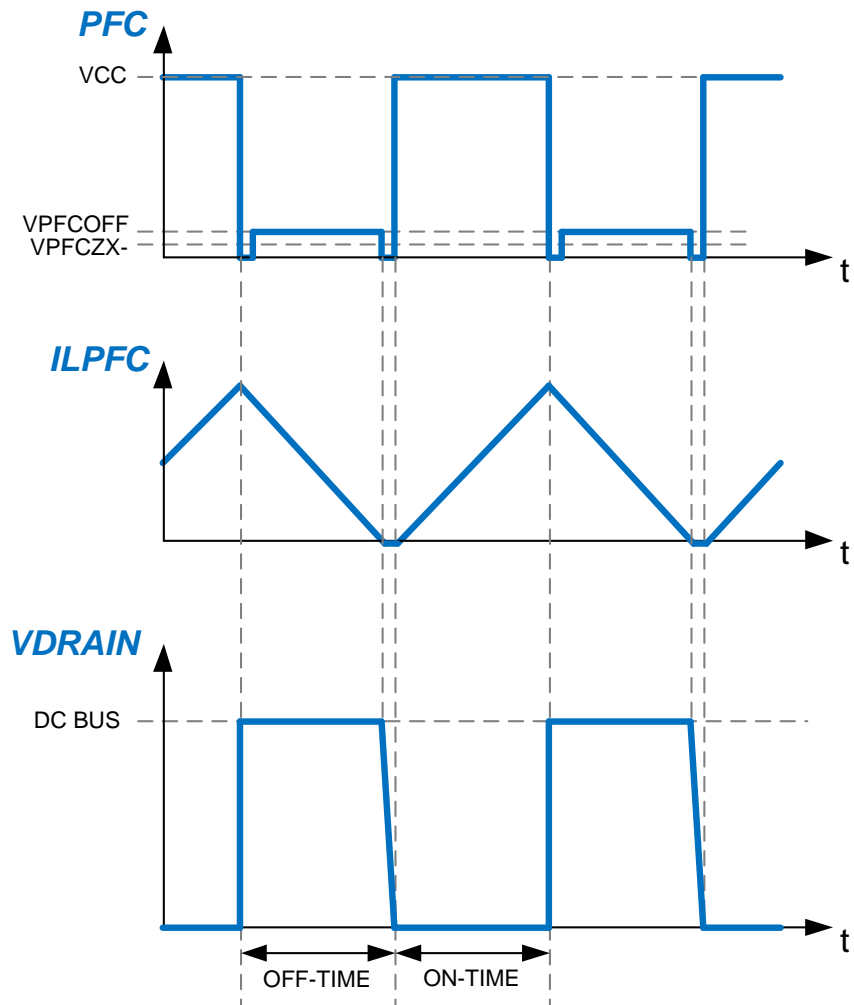
**Timing Diagram**

**Qualification Information<sup>†</sup>**

<b>Qualification Level</b>		Industrial <sup>††</sup> (per JEDEC JESD 47E)	
		Comments: This family of ICs has passed JEDEC's Industrial qualification. IR's Consumer qualification level is granted by extension of the higher Industrial level.	
<b>Moisture Sensitivity Level</b>		SOT-23	MSL1 <sup>†††</sup> (per IPC/JEDEC J-STD-020C)
<b>ESD</b>	Machine Model	Class B (per JEDEC standard EIA/JESD22-A115-A)	
	Human Body Model	Class 2 (per EIA/JEDEC standard JESD22-A114-B)	
<b>IC Latch-Up Test</b>		Class I, Level A (per JESD78A)	
<b>RoHS Compliant</b>		Yes	

† Qualification standards can be found at International Rectifier's web site <http://www.irf.com/>

†† Higher qualification ratings may be available should the user have such requirements. Please contact your International Rectifier sales representative for further information.

††† Higher MSL ratings may be available for the specific package types listed here. Please contact your International Rectifier sales representative for further information.

## Absolute Maximum Ratings

Absolute maximum ratings indicate sustained limits beyond which damage to the device may occur. All voltage parameters are absolute voltages referenced to COM, all currents are defined positive into any pin. The thermal resistance and power dissipation ratings are measured under board mounted and still air conditions.

Symbol	Definition	Min.	Max.	Units	
<b>VPFC</b>	PFC pin voltage	-0.3	VCC + 0.3	V	
<b>VBUS</b>	VBUS pin voltage	-0.3	VCC + 0.3		
<b>ICC</b>	VCC pin supply current <sup>†</sup>	---	25	mA	
<b>ICMP</b>	CMP pin current <sup>††</sup>	---	1		
<b>PD</b>	Package power dissipation @ Ta ≤ +25 °C	SOT-23 5L	---	250	mW
<b>Rθja</b>	Thermal resistance, junction to ambient	SOT-23 5L	---	191	°C/W
<b>Tj</b>	Junction temperature	-55	150	°C	
<b>Ts</b>	Storage temperature	-55	150		
<b>TL</b>	Lead temperature (soldering, 10 seconds)	---	300		

† This IC contains a voltage clamp structure between the chip VCC and COM which has a nominal breakdown voltage of 20.8V. This supply pin should not be driven by a DC, low impedance power source greater than the VCLAMP specified in the Electrical Characteristics section.

†† This IC contains a voltage clamp structure between the CMP and COM which has a nominal breakdown voltage of 10.2V. This pin should not be driven by a DC, low impedance power source greater than the VZCMP specified in the Electrical Characteristics section.

### Recommended Operating Conditions

For proper operation the device should be used within the recommended conditions.

Symbol	Definition	Min.	Max.	Units
<b>VCC</b>	Supply voltage	VCCUV+ + 0.5V	VCLAMP	V
<b>ICC</b>	Supply current	0	10	mA
<b>VCMP</b>	CMP pin voltage	0	VZCMP	V
<b>Tj</b>	Junction temperature	-40	125	°C

### Recommended Component Values

Symbol	Component	Min.	Max.	Units
<b>CCMP</b>	Compensation capacitor value	470	---	nF
<b>CVCC</b>	VCC filter capacitor	100	---	nF
<b>CVBUS</b>	VBUS pin filter capacitor	1.0	---	nF

**Electrical Characteristics**

VCC=14V, CVCC=0.1uF, CCMP=0.68uF, CPFC=1nF, CVBUS=10nF, and Ta=25°C unless otherwise specified.

Symbol	Definition	Min	Typ	Max	Units	Test Conditions
<b>Supply Characteristics</b>						
<b>VCLAMP</b>	VCC clamp voltage	19.8	20.8	21.8	V	ICC = 19 mA
<b>VCCUV+</b>	Rising VCC under-voltage lock-out threshold	10.0	11.1	12.0		N/A
<b>VCCUV-</b>	Falling VCC under-voltage lock-out threshold	7.0	7.9	9.0		
<b>VCCUVHYS</b>	VCC UVLO hysteresis	---	3.2	---		
<b>IQCCUV</b>	Micro-power start-up VCC supply current	---	---	60.0	μA	VCC = VCCUV+ - 500mV rising
<b>ICC50kHz</b>	VCC current @ 50kHz	---	2.5	---	mA	MOSFET = IRF840A
<b>PFC Characteristics</b>						
<b>VBUSREG</b>	VBUS Pin Regulation Voltage	4.02	4.1	4.18	V	
<b>VBUSOV+</b>	VBUS Pin OVP Threshold	---	4.47	---		
<b>VBUSOV-</b>	VBUS Pin OVP Fault Reset Threshold	---	4.26	---		
<b>VBUSOC+</b>	VBUS Pin Over-Current Threshold	---	0.56	---		VBUS = 3V
<b>tWD</b>	Watch Dog Timer Pulse Interval	---	125	---		
<b>ICMP+</b>	CMP Pin OTA IO+	---	30	---	μA	VBUS=3.5V, VCMP=0V
<b>ICMP-</b>	CMP Pin OTA IO-	---	-30	---		VBUS=4.5V, VCMP=5V
<b>VCMP<sub>OH</sub></b>	OTA Output Voltage Swing (high state)	9.9	10.2	11.5	V	VBUS=3.5V
<b>VCMP<sub>POL</sub></b>	OTA Output Voltage Swing (low state)	---	0	---		VBUS=4.5V
<b>VCMP<sub>FLT</sub></b>	OTA Output Voltage in Fault Mode	---	0	---		
<b>VZCMP</b>	CMP Pin Clamp Voltage	9.9	10.2	11.5		VBUS=3.5V
<b>Gate Driver Output Characteristics (PFC)</b>						
<b>VPFCON</b>	Gate High Voltage	---	VCC	---	V	
<b>VPFCOFF</b>	Gate Low Voltage	---	0.59	---		
<b>tf</b>	Output fall time	---	20	---	nsec	Falling, 80% to 20%
<b>IO-</b>	Output sink current	---	450	---	mA	

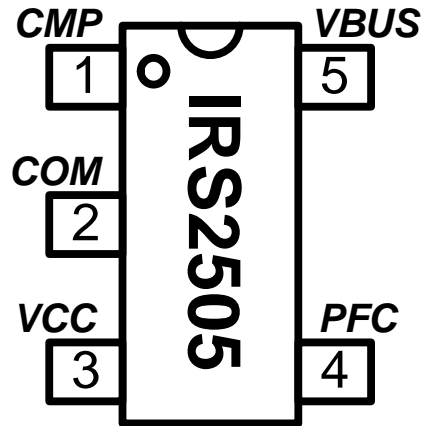
**Pin Assignments and Definitions**

Pin	Name	Description
<b>1</b>	<b><i>CMP</i></b>	PFC error amplifier compensation
<b>2</b>	<b><i>COM</i></b>	IC power and signal ground
<b>3</b>	<b><i>VCC</i></b>	Logic and gate drive supply voltage
<b>4</b>	<b><i>PFC</i></b>	PFC gate driver output and zero-crossing detection
<b>5</b>	<b><i>VBUS</i></b>	DC bus sensing input, OVP and OCP

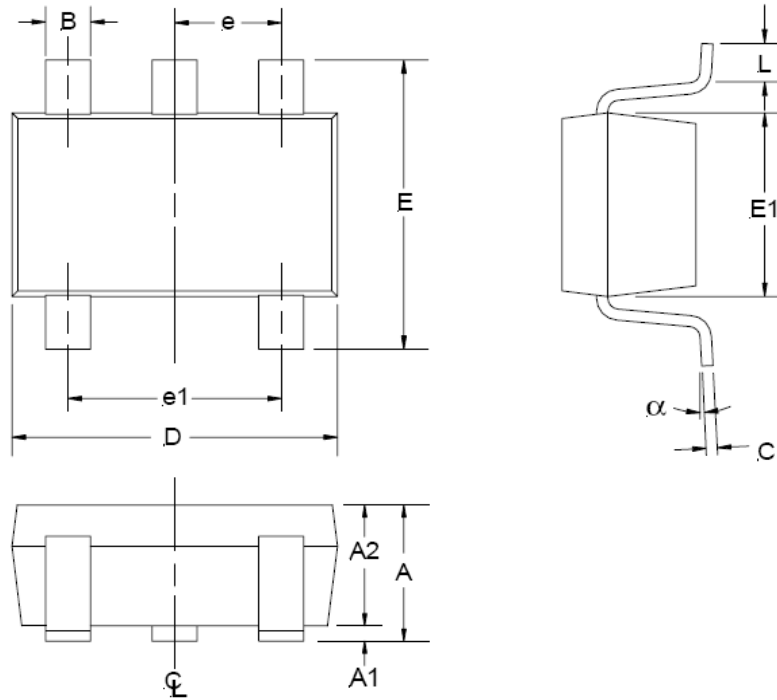
**Package Details: 5 Lead SOT23**

SYMBOL	MIN	MAX
A	0.90	1.45
A1	0.00	0.15
A2	0.90	1.30
B	0.25	0.50
C	0.09	0.20
D	2.80	3.00
E	2.60	3.00
E1	1.50	1.75
e	0.95 REF	
e1	1.90 REF	
L	0.35	0.55
$\alpha$	0°	10°

NOTE: ALL MEASUREMENTS  
ARE IN MILLIMETERS.

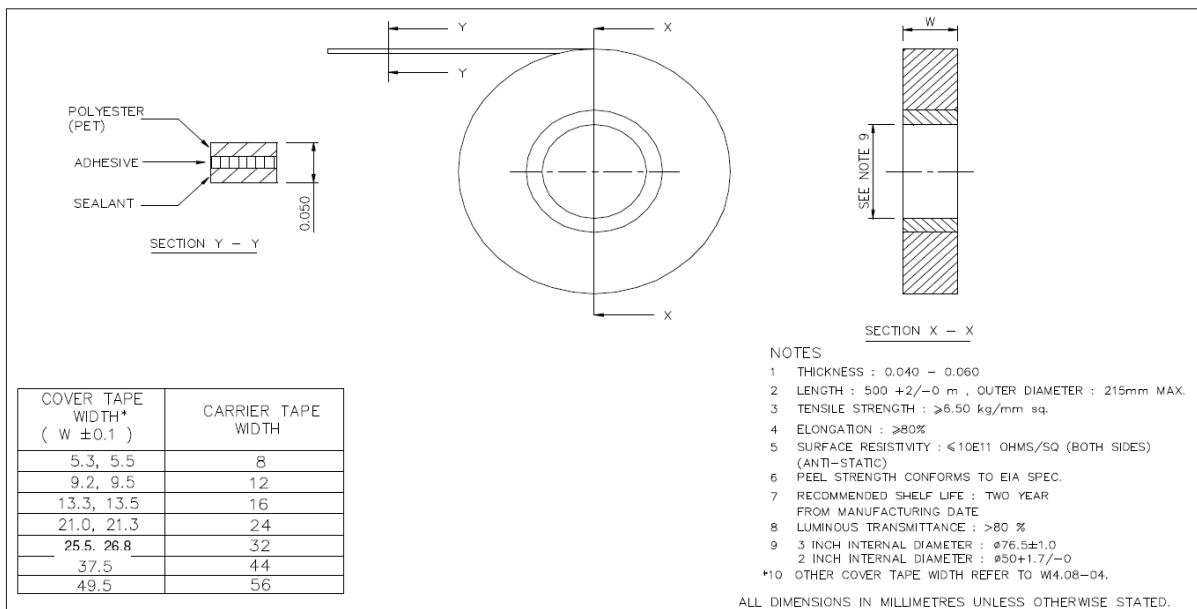
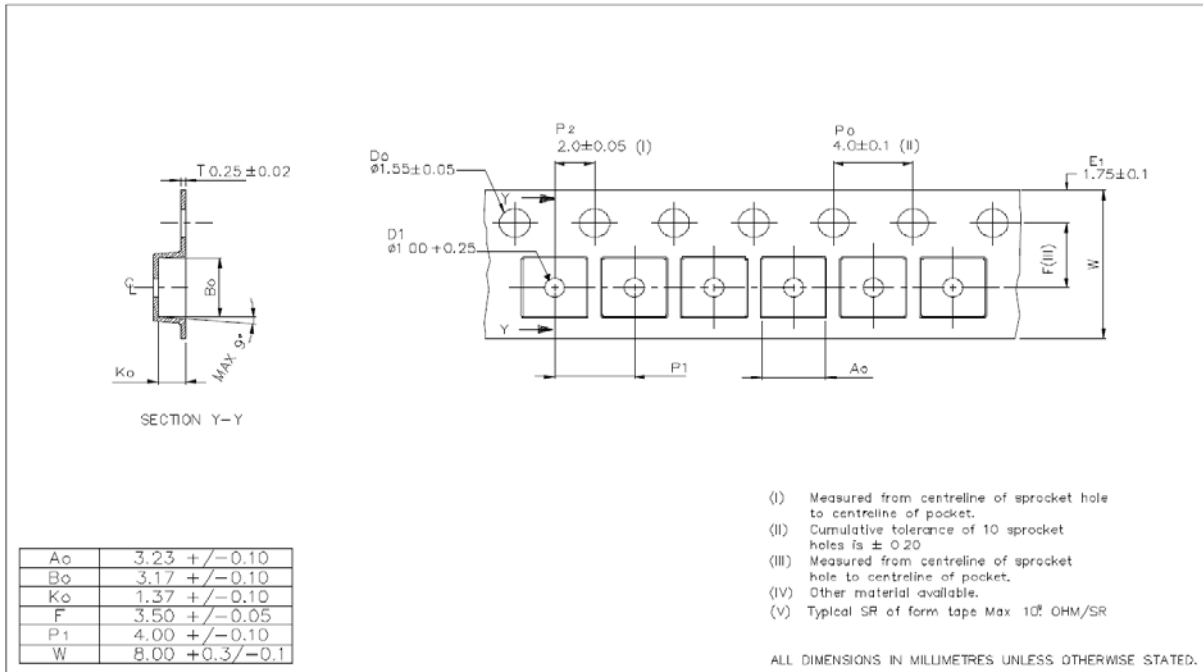

**Tape and Reel Details: 5 Lead SOT23**

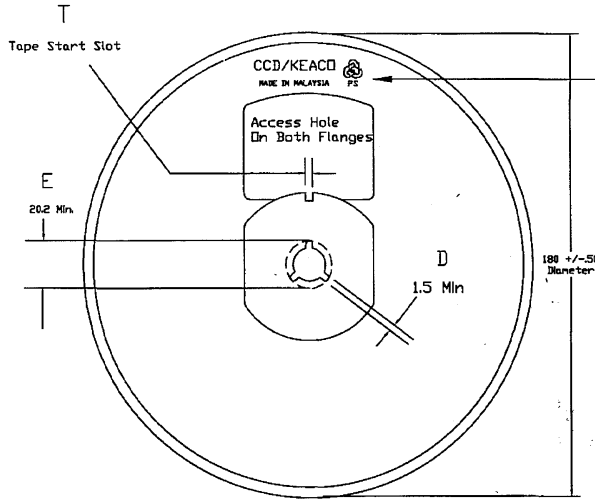
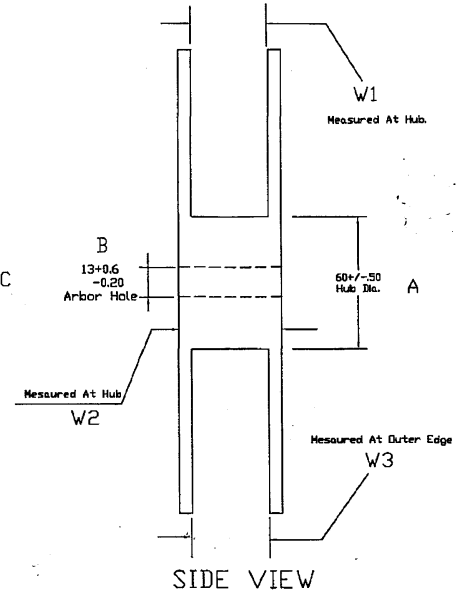
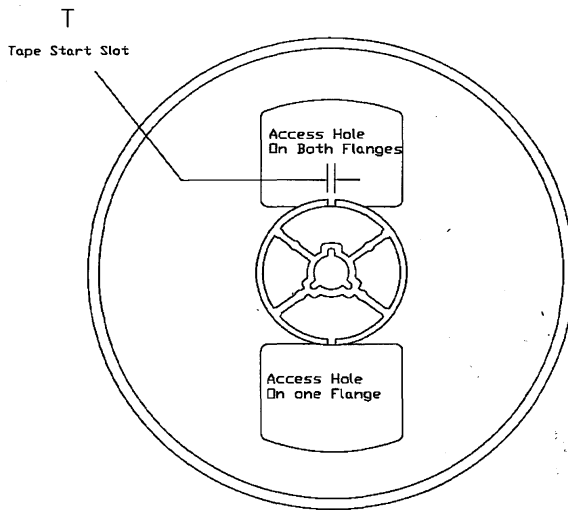
**Tape and Reel Details: 5 Lead SOT23**

**FRONT VIEW**

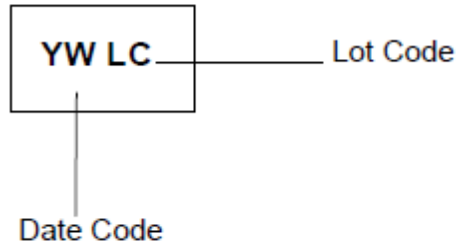
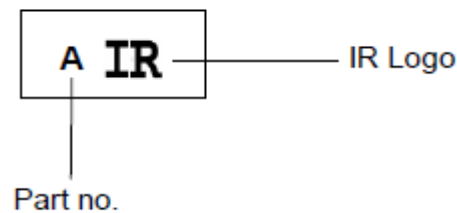
**SIDE VIEW**

**BACK VIEW**
**NOTE:**

1. MATERIAL : POLYSTRENE
2. SURFACE RESISTIVITY :  $\leq 10E11$  OHMS/SQ (EXTERNAL OR DIPPED)
3. STATIC DECAY :  $< 2$ SEC. AT 50%RH

**Part Marking Information: 5 Lead SOT23**
**Top Marking**

**Bottom Marking**

The information provided in this document is believed to be accurate and reliable. However, International Rectifier assumes no responsibility for the consequences of the use of this information. International Rectifier assumes no responsibility for any infringement of patents or of other rights of third parties which may result from the use of this information. No license is granted by implication or otherwise under any patent or patent rights of International Rectifier. The specifications mentioned in this document are subject to change without notice. This document supersedes and replaces all information previously supplied.

For technical support, please contact IR's Technical Assistance Center  
<http://www.irf.com/technical-info/>

**WORLD HEADQUARTERS:**  
 233 Kansas St., El Segundo, California 90245  
 Tel: (310) 252-7105